

Description

The AL5802 combines a high gain NPN transistor with a pre-biased NPN transistor to make a simple small footprint LED driver.

The LED current is set by an external resistor connected from REXT pin (6) to GND pin (4). The internal high gain transistor develops approximately 0.6V across the external resistor.

The AL5802's open-collector output can operate from 0.8V to 30V, making it suitable for industry-standard 5V to 24V power supplies without additional components.

PWM dimming of the LED current can be achieved by either driving the BIAS pin (2) with a low impedance voltage source, or driving the EN pin (3) with an external open-collector NPN transistor or open-drain N-channel MOSFET.

The AL5802 is available in the SOT26 (SC74R) package and is ideal for driving 20mA to 120mA LED currents.

Features

- Reference voltage VRSET = 0.65V
- -40 to +125°C temperature range
- 0.8V to 30V open-collector output
- Negative temperature co-efficient automatically reduces the LED current at high temperatures
- Low thermal impedance SOT26 with copper lead-frame
- **Totally Lead-Free & Fully RoHS Compliant (Notes 1 & 2)**
- **Halogen- and Antimony-Free. "Green" Device (Note 3)**
- **For automotive applications requiring specific change control (i.e.: parts qualified to AEC-Q100/101/200, PPAP capable, and manufactured in IATF 16949 certified facilities), please refer to the related automotive grade (Q-suffix) part. A listing can be found at <https://www.diodes.com/products/automotive/automotive-products/>.**
- **This part is qualified to JEDEC standards (as references in AEC-Q) for High Reliability. <https://www.diodes.com/quality/product-definitions/>**

- Notes:
1. No purposely added lead. Fully EU Directive 2002/95/EC (RoHS), 2011/65/EU (RoHS 2) & 2015/863/EU (RoHS 3) compliant.
 2. See <https://www.diodes.com/quality/lead-free> for more information about Diodes Incorporated's definitions of Halogen- and Antimony-free, "Green" and Lead-free.
 3. Halogen- and Antimony-free "Green" products are defined as those which contain <900ppm bromine, <900ppm chlorine (<1500ppm total Br + Cl) and <1000ppm antimony compounds.

Pin Assignments

(Top View)

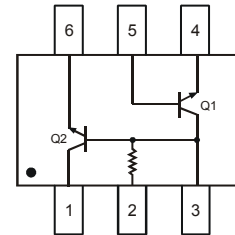

SOT26

Applications

- Linear LED drivers
- LED signs
- Offline LED luminaries

Typical Application Circuit

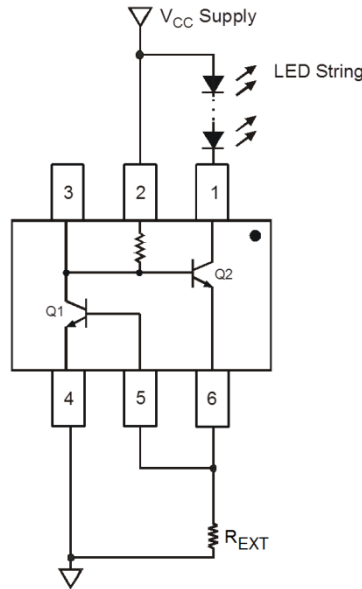

Pin Descriptions

Pin Number	Name	Function
1	OUT	Open-collector LED driver output
2	BIAS	Biases the open collector output transistor
3	EN	Enable pin for PWM dimming. Provides access to the base of Q2 and collector of Q1
4	GND	Ground reference point for setting LED current
5	FB	Feedback pin. Should be connected to pin 6.
6	REXT	Current sense pin. LED current sensing resistor should be connected from here to GND.

Functional Block Diagram

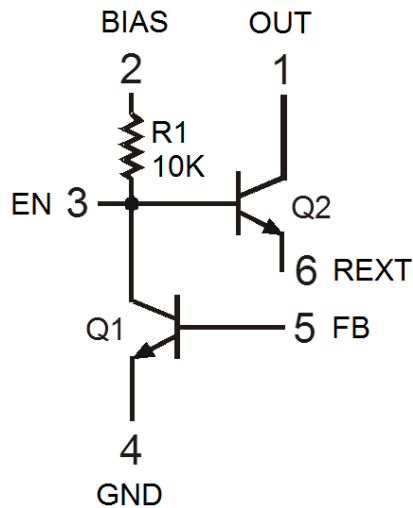

Fig. 1 Block Diagram

Absolute Maximum Ratings

These are stress ratings only. Operation outside the absolute maximum ratings may cause device failure. Operation at the absolute maximum rating for extended periods may reduce device reliability.

Symbol	Characteristics	Values	Unit
V _{OUT}	Output voltage relative to GND	30	V
V _{BIAS}	BIAS voltage relative to GND (Note 4)	30	V
V _{FB}	LED voltage relative to GND	6	V
V _{EN}	EN voltage relative to GND	6	V
V _{REXT}	REXT voltage relative to GND	6	V
I _{OUT}	Output current	150	mA
T _J	Operating junction temperature	-40 to +150	°C
T _{ST}	Storage temperature	-55 to +150	°C

Note: 4. With pins 5 and 6 connected together.

Package Thermal Data

Characteristic	Symbol	Value	Unit
Power Dissipation (Note 5) @ T _A = +25°C	P _D	0.37	W
Power Dissipation (Note 6) @ T _A = +25°C		0.87	
Thermal Resistance, Junction to Ambient Air (Note 5) @ T _A = +25°C	R _{θJA}	335	°C/W
Thermal Resistance, Junction to Ambient Air (Note 6) @ T _A = +25°C		143	

Notes: 5. Device mounted on FR-4 PCB, 2oz with minimum recommended pad layout.
6. Device mounted on 25mm x 25mm 2oz copper board.

Recommended Operating Conditions

Symbol	Parameter	Min	Max	Unit
V _{BIAS}	Supply voltage range	4.5	30	V
V _{OUT}	OUT voltage range	0.8	30	
I _{LED}	LED pin current (Note 7)	10	120	mA
T _A	Operating ambient temperature range	-40	+125	°C

Note: 7. Subject to ambient temperature, power dissipation and PCB.

Electrical Characteristics – NPN Transistor – Q1 (@ $T_A = +25^\circ\text{C}$, unless otherwise specified.)

Symbol	Characteristic	Test Condition	Min	Typ	Max	Unit
$V_{(BR)CEO}$	Collector-Emitter Breakdown Voltage (Note 8)	$I_C = 1.0\text{mA}, I_B = 0$	40	—	—	V
$V_{(BR)EBO}$	Emitter-Base Breakdown Voltage	$I_E = 10\mu\text{A}, I_C = 0$	6.0	—	—	V
I_{CEX}	Collector Cutoff Current	$V_{CE} = 30\text{V}, V_{EB(OFF)} = 3.0\text{V}$	—	—	50	nA
I_{BL}	Base Cutoff Current	$V_{CE} = 30\text{V}, V_{EB(OFF)} = 3.0\text{V}$	—	—	50	nA
h_{FE}	DC Current Gain	$I_C = 100\mu\text{A}, V_{CE} = 1.0\text{V}$ $I_C = 1.0\text{mA}, V_{CE} = 1.0\text{V}$ $I_C = 10\text{mA}, V_{CE} = 1.0\text{V}$	40 70 100	— — —	— — 300	—
$V_{CE(SAT)}$	Collector-Emitter Saturation Voltage (Note 8)	$I_C = 10\text{mA}, I_B = 1.0\text{mA}$	—	—	0.20	V
$V_{BE(SAT)}$	Base-Emitter Saturation Voltage	$I_C = 10\text{mA}, I_B = 1.0\text{mA}$	0.65	—	0.85	V

Electrical Characteristics – NPN Pre-biased Transistor – Q2 (@ $T_A = +25^\circ\text{C}$, unless otherwise specified.)

Symbol	Characteristic	Test Condition	Min	Typ	Max	Unit
$V_{(BR)CBO}$	Collector-Base Breakdown Voltage	$I_C = 50\mu\text{A}, I_E = 0$	30	—	—	V
$V_{(BR)CEO}$	Collector-Emitter Breakdown Voltage (Note 8)	$I_C = 1\text{mA}, I_B = 0$	30	—	—	V
$V_{(BR)EBO}$	Emitter-Base Breakdown Voltage	$I_E = 50\mu\text{A}, I_C = 0$	5.0	—	—	V
I_{CBO}	Collector Cut-Off Current	$V_{CB} = 30\text{V}, I_E = 0$	—	—	0.5	μA
I_{EBO}	Emitter Cut-Off Current	$V_{EB} = 4\text{V}, I_C = 0$	—	—	0.5	μA
$V_{CE(SAT)}$	Collector-Emitter Saturation Voltage (Note 8)	$I_C = 10\text{mA}, I_B = 1\text{mA}$	—	—	0.3	V
h_{FE}	DC Current Gain (Note 9)	$V_{CE} = 5\text{V}, I_C = 150\text{mA}$	100	—	—	—
R_1	Input Resistance	—	7	10	13	k Ω

*Characteristics of transistor only.

Note: 8. Short duration pulse test used to minimize self-heating effect.

Thermal Characteristics

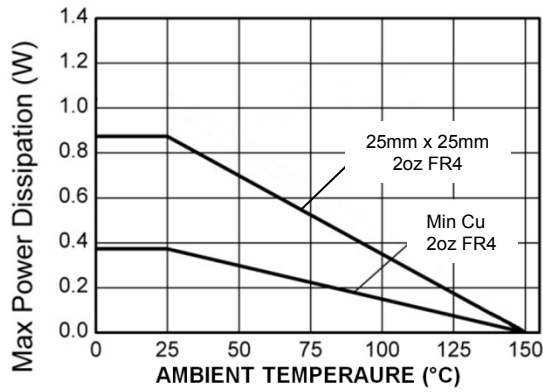

Fig. 2 Derating Curve

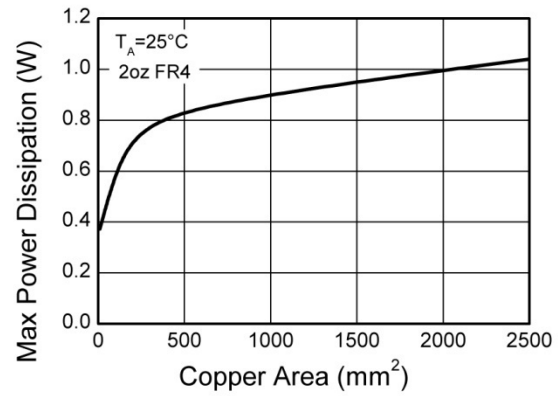

Fig. 3 Max Power vs. Area

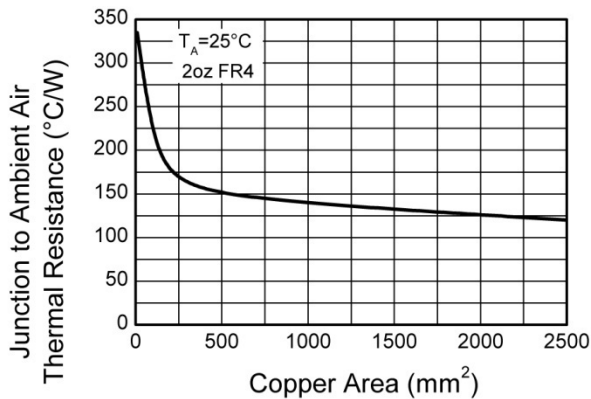

Fig. 4 Thermal Resistance vs. Area

Typical Performance Characteristics

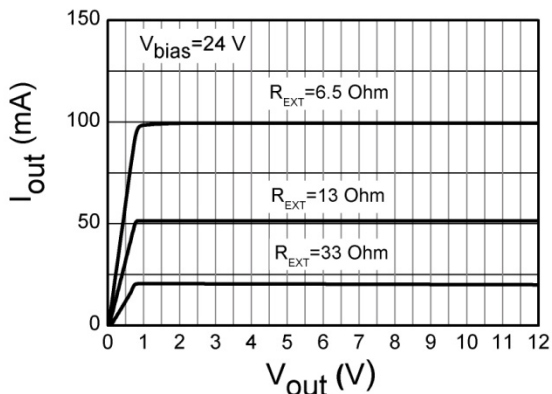

Fig. 5 Output Current vs. Vout

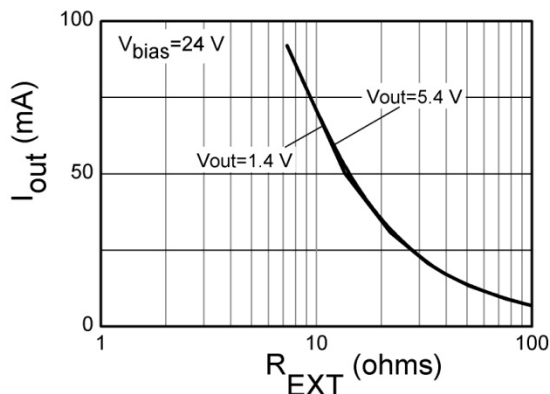

Fig. 6 Output Current vs. REXT

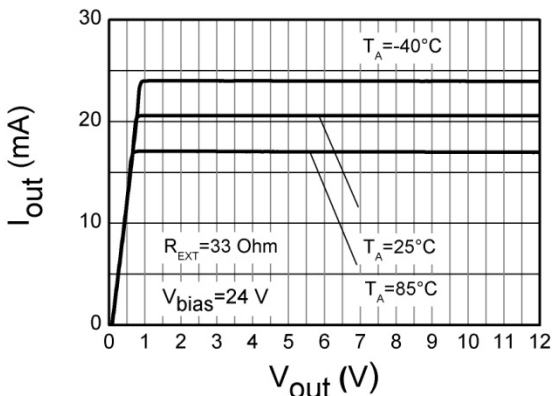

Fig. 7 Output Current vs. Vout

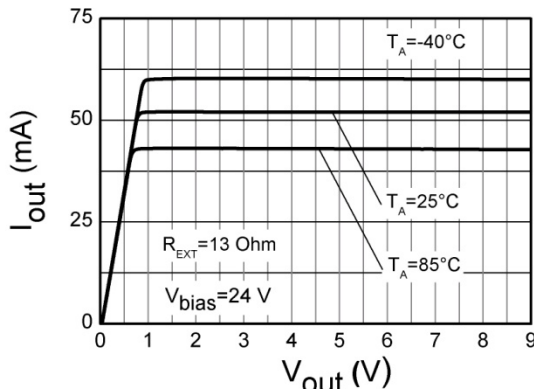

Fig. 8 Output Current vs. Vout

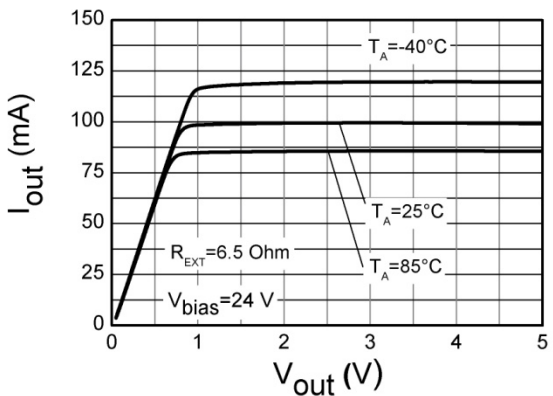

Fig. 9 Output Current vs. Vout

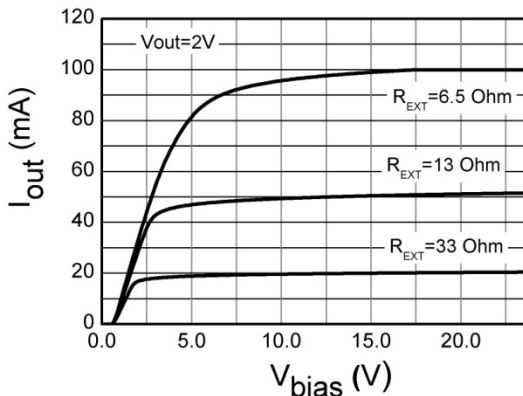

Fig. 10 Output Current vs. VBIAS

Note: 10. Vout in the "Output Current vs. Vout" graphs limited by power dissipation in the device.

Typical Performance Characteristics (continued)

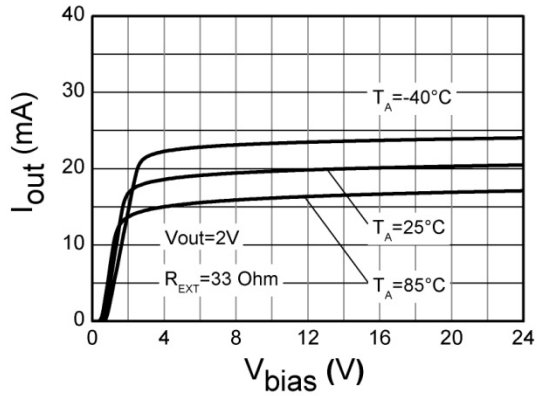

Fig. 11 Output Current vs. V_{BIAS}

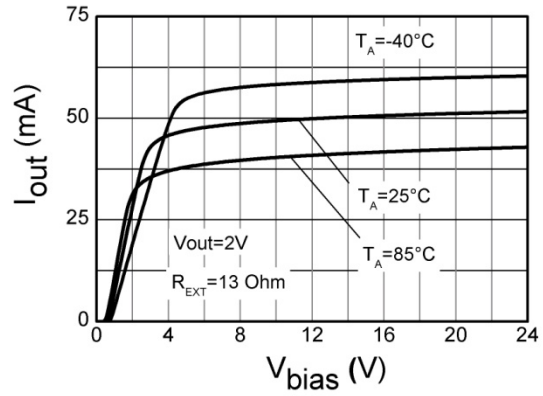

Fig. 12 Output Current vs. V_{BIAS}

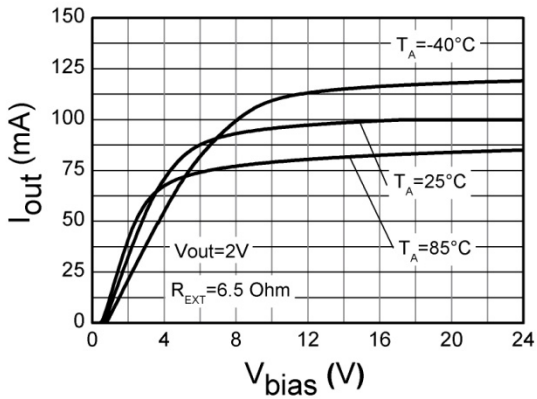

Fig. 13 Output Current vs. V_{BIAS}

Application Information

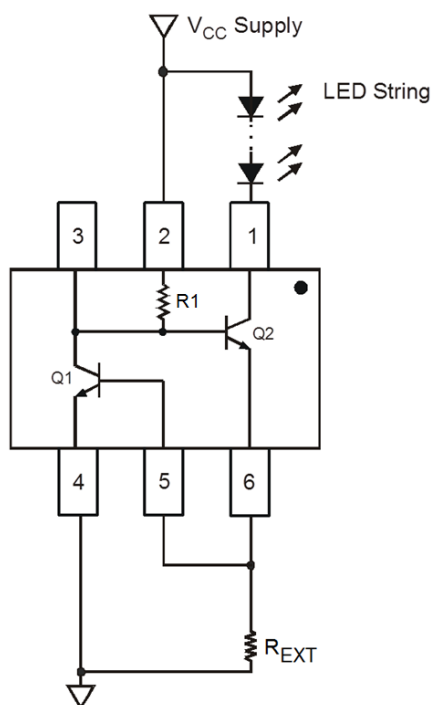

Fig. 14 Typical Application Circuit for Linear Mode Current Sink LED Driver

The AL5802 is designed for driving low current LEDs with a typical LED current of 20mA to 100mA. It provides a cost effective way for driving low current LEDs compared to more complex switching regulator solutions. Furthermore, it reduces the PCB board area of the solution as there is no need for external components like inductors, capacitors, and switching diodes.

Figure 14 shows a typical application circuit diagram for driving an LED or string of LEDs. The NPN transistor Q1 measures the LED current by sensing the voltage across the external resistor R_{EXT}. Q1 uses its V_{BE} as a reference to set the voltage across the R_{EXT} and to control the base current into Q2. Q2 operates in linear mode to regulate the LED current. The LED current is,

$$I_{LED} = V_{BE(Q1)} / R_{EXT}$$

From this, necessary LED currents by the external resistor R_{EXT} can be calculated from,

$$R_{EXT} = V_{BE(Q1)} / I_{LED}$$

Two or more AL5802 devices can be connected in parallel to construct higher current LED strings, as shown in Figure 15.

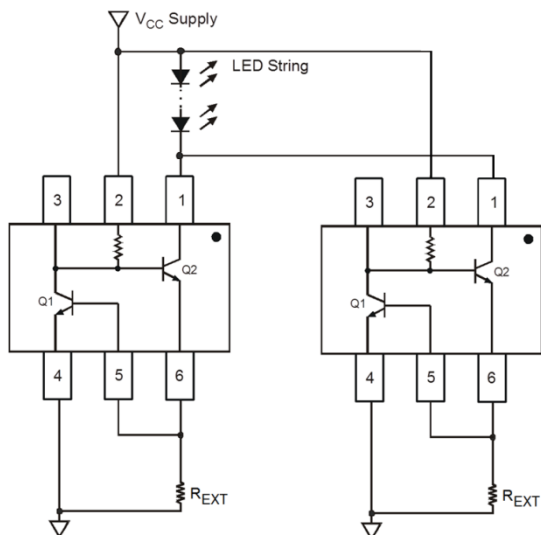

Fig. 15 Application Circuit for Increasing LED Current

Consideration of the expected linear-mode power dissipation must be factored into the design with respect to the AL5802's thermal resistance. The maximum voltage across the device can be calculated by using the maximum supply voltage and the voltage across the LED string.

$$V_{CE(Q2)} = V_{CC} - V_{LED} - V_{BE(Q1)}$$

$$P_D = V_{CE(Q2)} * I_{LED} + (V_{CC} - V_{BE(Q2)} - V_{BE(Q1)})^2 / R_1$$

As the output current of AL5802 increases, it is necessary to provide appropriate thermal relief to the device. The power dissipation supported by the device is dependent upon the PCB board material, the copper area, and the ambient temperature. The maximum dissipation the device can handle is given by,

$$P_D = (T_{J(MAX)} - T_A) / R_{\theta JA}$$

Refer to the thermal characteristic graphs on page 5 for selecting the appropriate PCB copper area.

Application Information (continued)

PWM dimming can be achieved by driving the EN pin. An external open-collector NPN transistor or open-drain N-channel MOSFET can be used to drive the EN pin, as shown in Figure 16. Dimming is achieved by turning the LEDs ON and OFF for a portion of a single cycle. The PWM signal can be provided by a micro-controller or analog circuitry. Figure 17 is a typical response of LED current vs. PWM duty cycle on the EN pin.

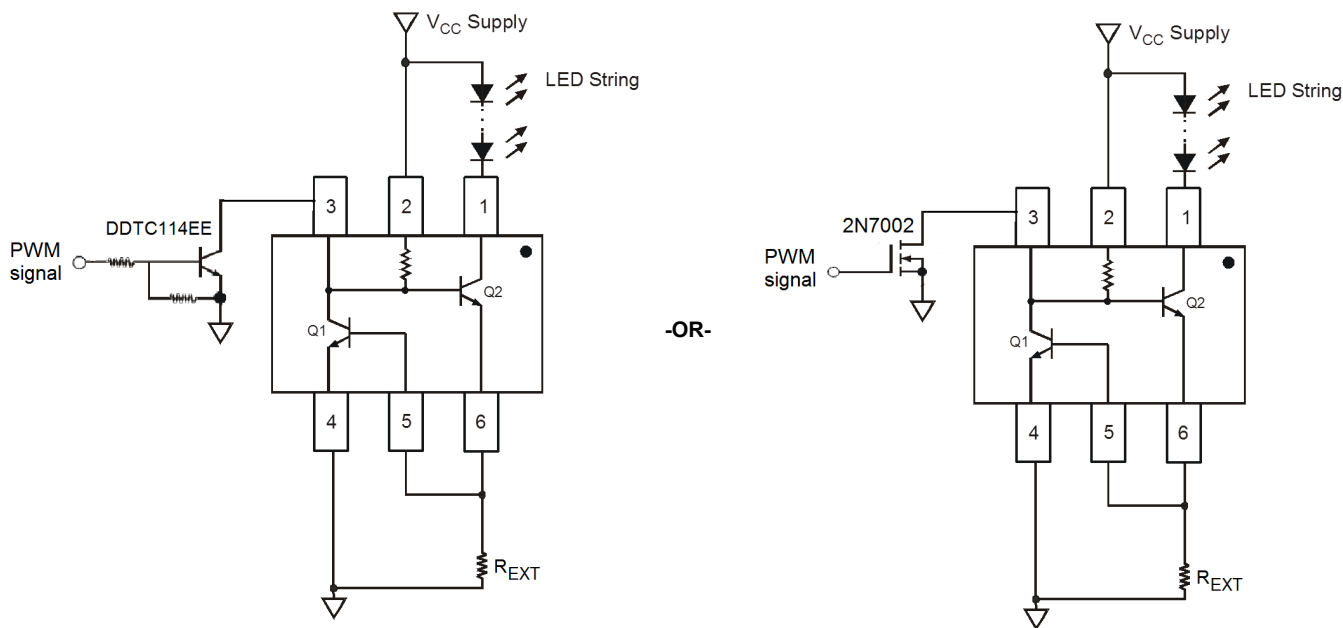

Fig. 16 Application Circuits for LED Driver with PWM Dimming Functionality

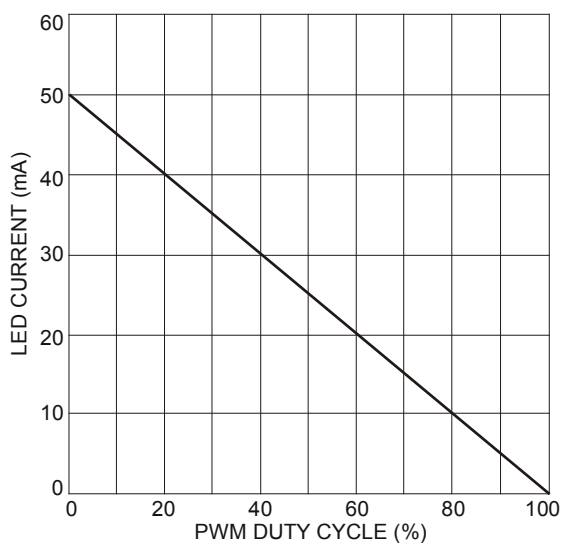

Fig. 17 Typical LED current response vs. PWM duty cycle for $R_{EXT} = 13\Omega$ at 400Hz PWM frequency

Application Information (continued)

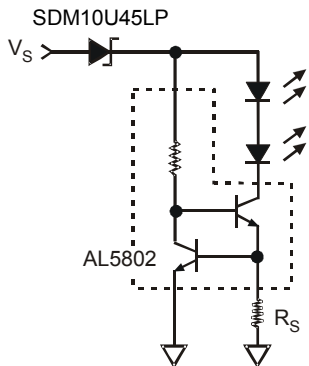

Fig. 18 Application circuit for LED driver with reverse polarity protection

To remove the potential of incorrect connection of the power supply damaging the lamp's LEDs, many systems use some form of reverse polarity protection.

One solution for reverse input polarity protection is to simply use a diode with a low V_F in-line with the driver/LED combination. The low V_F increases the available voltage to the LED stack and dissipates less power. A circuit example is presented in Fig. 18 using Diodes Inc. SBR® (Super Barrier Rectifier) technology. An SDM10U45LP (0.1A/45V) is shown, providing exceptionally low V_F for its package size of 1mm x 0.6mm, equivalent to 0402 chip style package. Other reverse voltage ratings are also available on Diodes' website, such as the SBR02U100LP (0.2A/100V) or SBR0220LP (0.2A/20V).

Automotive applications commonly use this method for reverse battery protection.

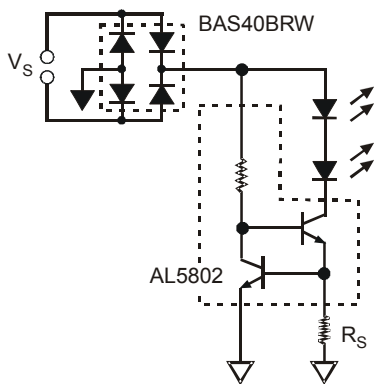

Fig. 19 Application circuit for LED driver with assured operation regardless of polarity

A second approach, shown in Fig. 19, improves upon the method shown in Fig. 18. Whereas the method in Fig. 18 protects the light engine, it will not function until the problem has been diagnosed and corrected.

The method shown in Fig. 19 not only provides reverse polarity protection, it also corrects the reversed polarity, allowing the light engine to function.

The BAS40BRW incorporates four low V_F , Schottky diodes into a single package, allowing more voltage available for the LED stack and dissipating less power than that of standard rectifier bridges.

Ordering Information (Note 11)

Device	Qualification	Packaging	Tape and Reel	
			Quantity	Part Number Suffix
AL5802	Commercial	SOT26 (SC74R)	3,000/Tape & Reel	-7
AL5802	Commercial	SOT26 (SC74R)	10,000/Tape & Reel	-13

Note: 11. For packaging details, go to our website at <https://www.diodes.com/design/support/packaging/diodes-packaging/>.

Marking Information

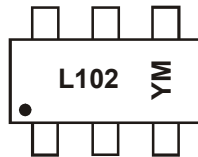

L102 = Product Type Marking Code
 YM = Date Code Marking
 Y = Year (ex: B = 2014)
 M = Month (ex: 9 = September)

Date Code Key

Year	2011	2012	2013	2014	2015	2016	2017	2018	2019
Code	Y	Z	A	B	C	D	E	F	G

Month	Jan	Feb	Mar	Apr	May	Jun	Jul	Aug	Sep	Oct	Nov	Dec
Code	1	2	3	4	5	6	7	8	9	O	N	D

Package Outline Dimensions

Please see <http://www.diodes.com/package-outlines.html> for the latest version.

SOT26 (SC74R)

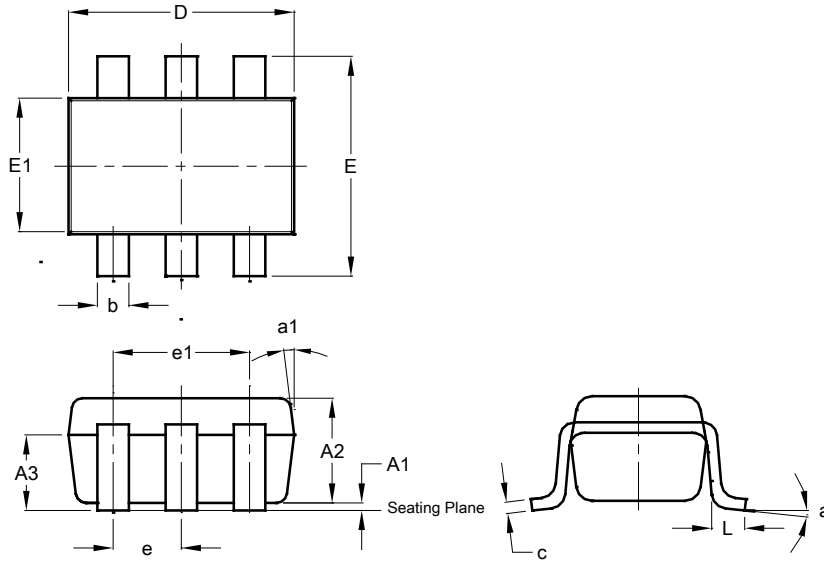

SOT26 (SC74R)			
Dim	Min	Max	Typ
A1	0.013	0.10	0.05
A2	1.00	1.30	1.10
A3	0.70	0.80	0.75
b	0.35	0.50	0.38
c	0.10	0.20	0.15
D	2.90	3.10	3.00
e	-	-	0.95
e1	-	-	1.90
E	2.70	3.00	2.80
E1	1.50	1.70	1.60
L	0.35	0.55	0.40
a	-	-	8°
a1	-	-	7°
All Dimensions in mm			

Suggested Pad Layout

Please see <http://www.diodes.com/package-outlines.html> for the latest version.

SOT26 (SC74R)

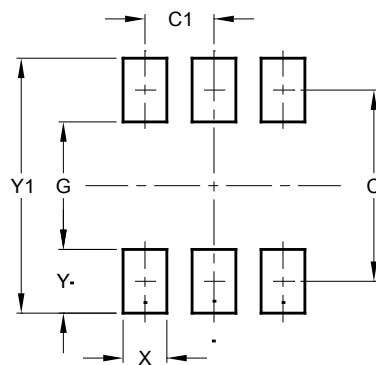

Dimensions	Value (in mm)
C	2.40
C1	0.95
G	1.60
X	0.55
Y	0.80
Y1	3.20

IMPORTANT NOTICE

1. DIODES INCORPORATED AND ITS SUBSIDIARIES (“DIODES”) MAKE NO WARRANTY OF ANY KIND, EXPRESS OR IMPLIED, WITH REGARDS TO ANY INFORMATION CONTAINED IN THIS DOCUMENT, INCLUDING, BUT NOT LIMITED TO, THE IMPLIED WARRANTIES OF MERCHANTABILITY, FITNESS FOR A PARTICULAR PURPOSE OR NON-INFRINGEMENT OF THIRD PARTY INTELLECTUAL PROPERTY RIGHTS (AND THEIR EQUIVALENTS UNDER THE LAWS OF ANY JURISDICTION).
2. The Information contained herein is for informational purpose only and is provided only to illustrate the operation of Diodes products described herein and application examples. Diodes does not assume any liability arising out of the application or use of this document or any product described herein. This document is intended for skilled and technically trained engineering customers and users who design with Diodes products. Diodes products may be used to facilitate safety-related applications; however, in all instances customers and users are responsible for (a) selecting the appropriate Diodes products for their applications, (b) evaluating the suitability of the Diodes products for their intended applications, (c) ensuring their applications, which incorporate Diodes products, comply the applicable legal and regulatory requirements as well as safety and functional-safety related standards, and (d) ensuring they design with appropriate safeguards (including testing, validation, quality control techniques, redundancy, malfunction prevention, and appropriate treatment for aging degradation) to minimize the risks associated with their applications.
3. Diodes assumes no liability for any application-related information, support, assistance or feedback that may be provided by Diodes from time to time. Any customer or user of this document or products described herein will assume all risks and liabilities associated with such use, and will hold Diodes and all companies whose products are represented herein or on Diodes’ websites, harmless against all damages and liabilities.
4. Products described herein may be covered by one or more United States, international or foreign patents and pending patent applications. Product names and markings noted herein may also be covered by one or more United States, international or foreign trademarks and trademark applications. Diodes does not convey any license under any of its intellectual property rights or the rights of any third parties (including third parties whose products and services may be described in this document or on Diodes’ website) under this document.
5. Diodes products are provided subject to Diodes’ Standard Terms and Conditions of Sale (<https://www.diodes.com/about/company/terms-and-conditions/terms-and-conditions-of-sales/>) or other applicable terms. This document does not alter or expand the applicable warranties provided by Diodes. Diodes does not warrant or accept any liability whatsoever in respect of any products purchased through unauthorized sales channel.
6. Diodes products and technology may not be used for or incorporated into any products or systems whose manufacture, use or sale is prohibited under any applicable laws and regulations. Should customers or users use Diodes products in contravention of any applicable laws or regulations, or for any unintended or unauthorized application, customers and users will (a) be solely responsible for any damages, losses or penalties arising in connection therewith or as a result thereof, and (b) indemnify and hold Diodes and its representatives and agents harmless against any and all claims, damages, expenses, and attorney fees arising out of, directly or indirectly, any claim relating to any noncompliance with the applicable laws and regulations, as well as any unintended or unauthorized application.
7. While efforts have been made to ensure the information contained in this document is accurate, complete and current, it may contain technical inaccuracies, omissions and typographical errors. Diodes does not warrant that information contained in this document is error-free and Diodes is under no obligation to update or otherwise correct this information. Notwithstanding the foregoing, Diodes reserves the right to make modifications, enhancements, improvements, corrections or other changes without further notice to this document and any product described herein. This document is written in English but may be translated into multiple languages for reference. Only the English version of this document is the final and determinative format released by Diodes.
8. Any unauthorized copying, modification, distribution, transmission, display or other use of this document (or any portion hereof) is prohibited. Diodes assumes no responsibility for any losses incurred by the customers or users or any third parties arising from any such unauthorized use.

Copyright © 2021 Diodes Incorporated

www.diodes.com