

RECOMMENDED PCB LAYOUT
(MOUNTING SURFACE SIDE)(5:1)

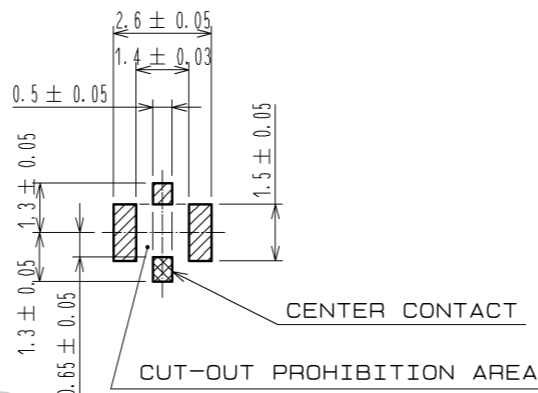

EMBOSSED TAPING DRAWING (4:1)

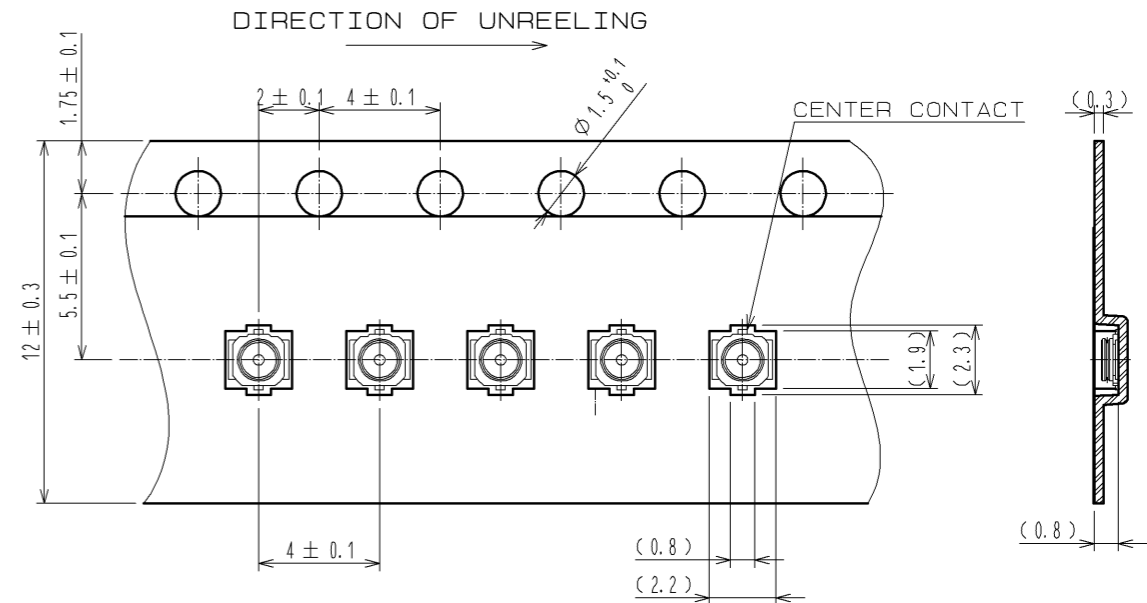

RECOMMENDED METAL MASK DIMENSIONS (5:1)
METAL MASK THICKNESS: 0.1mm/0.12mm

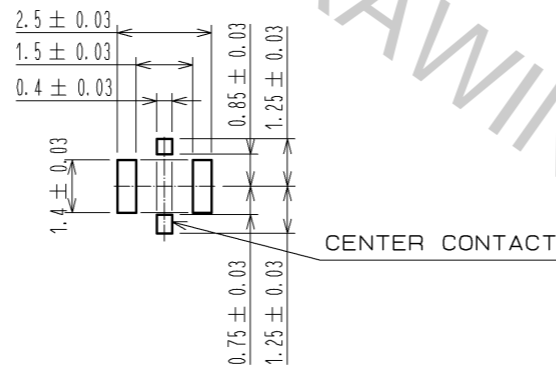

REEL DRAWING (SCALE FREE)

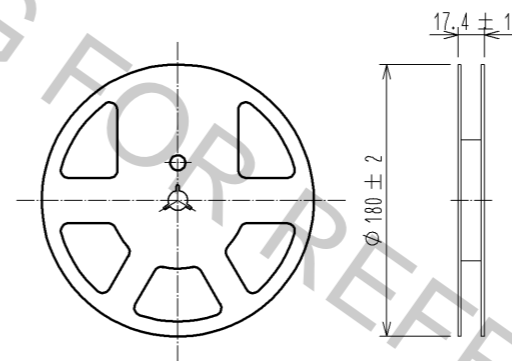

A (SCALE FREE)

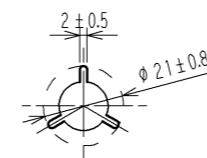

REFLOW TEMPERATURE PROFILE USING
LEAD-FREE SOLDER PASTE (REFERENCE)

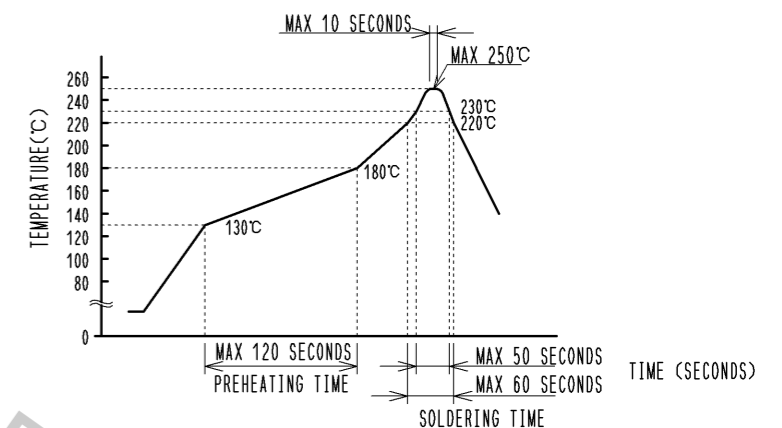

- 1) REFLOW TIME
 REFLOW METHOD : IR REFLOW
 NUMBER OF REFLOW CYCLES : 2 CYCLES MAX.
 DURATION ABOVE 220 °C : 60 SEC. MAX.
 DURATION ABOVE 230 °C : 50 SEC. MAX.
 (PEAK TEMPERATURE : 250°C 10 SEC. MAX.)
- 2) PRE-HEAT TIME
 PRE-HEAT TEMPERATURE(MIN) : 130 °C
 PRE-HEAT TEMPERATURE(MAX) : 180 °C
 PRE-HEAT TIME: 120 SEC. MAX.

THIS TEMPERATURE PROFILE IS PER THE CONDITIONS SHOWN ABOVE.
 ADDITIONAL FACTORS, SUCH AS SOLDER PASTE TYPE,
 PCB SIZE AND OTHER MOUNTED COMPONENTS COULD AFFECT THE PROFILE. THEREFORE,
 A THOROUGH EVALUATION OF MOUNTING CONDITION IS REQUIRED PRIOR TO PRODUCTION.
 TEMPERATURE IS MEASURED AT CONTACT LEAD.

RoHS COMPLIANT

NOTES:

- 1: THE QUANTITY OF X.FL-R-SMT-1(02) IS 500 CONNECTORS PER REEL.
- 2 THIS DIMENSION SHOWS THE ALLOWABLE RANGE THAT THE RESIN IS PUT OVER THE CENTER CONTACT.
- 3: LEAD CO-PLANARITY SHALL BE 0.08MAX.
- 4: FOR THE POSSIBILITY OF BREAKAGE OR DEFORMATION DO NOT MATE THIS CONNECTOR WITH PARTNER, X.FL-LP-040 BEFORE MOUNTING ON PC BOARD.
- 5: USE ALL PRODUCTS WITHIN 6 MONTHS AFTER THE DELIVERY. STORE THEM IN MANUFACTURER'S PACKAGE OR TIGHTLY RE-CLOSED BOX WITH THE FOLLOWING CONDITIONS. CHECK THE TERMINAL SOLDERABILITY BEFORE USE IF THE PRODUCT HAS BEEN STORED FOR MORE THAN 6 MONTHS.
 TEMPERATURE: -10°C TO +40°C
 HUMIDITY : 15 TO 85% RH.
- 6: ENVIRONMENTAL CONDITIONS DO NOT USE THE PRODUCTS UNDER THE ENVIRONMENTAL CONDITIONS AS SHOWN BELOW DUE TO POSSIBLE PRODUCT DETERIORATION.
 SPECIAL GAS ATMOSPHERE (HYDROGEN SULFIDE GAS, SULFUR SULFIDE GAS AND HYDROGEN CHLORIDE GAS)
 PLACE ATTENTION REQUIRED: HEATING SYSTEM, AREA NEAR HOT SPRING, VOLCANIC MOUNTAIN AND ALIKE.
 WATER SPLASHED AND CONDENSATION PLACES.
 PLACE ATTENTION REQUIRED: HARSH TEMPERATURE CHANGE.

1	PHOSPHOR BRONZE	UNDER PLATING: NICKEL OVER PLATING: SELECTIVE GOLD	3	LCP	(BLACK), UL94V-0
2			2	BRASS	UNDER PLATING: NICKEL OVER PLATING: SELECTIVE GOLD
NO.	MATERIAL	FINISH . REMARKS	NO.	MATERIAL	FINISH . REMARKS
UNITS mm		SCALE 10:1	COUNT 	DESCRIPTION OF REVISIONS	DESIGNED
HRS HIROSE ELECTRIC CO., LTD.		APPROVED : KY. SHIMIZU	14.09.18	DRAWING NO.	EDC3-318791-02
		CHECED : MT. KANEKO	14.09.18	PART NO.	X.FL-R-SMT-1(02)
		DESIGNED : MS. MATSUMOTO	14.09.18	CODE NO.	CL331-0701-8-02
		DRAWN : MS. MATSUMOTO	14.09.18		