

LMR61428 SIMPLE SWITCHER® 14V_{out}, 2.85A Step-Up Voltage Regulator in VSSOP

 Check for Samples: [LMR61428](#)

FEATURES

- 1.2V to 14V Input Voltage
- Adjustable Output Voltage up to 14V
- Switch Current up to 2.85A
- Up to 2 MHz Switching Frequency
- Low Shutdown I_q, <1μA
- Cycle-by-Cycle Current Limiting
- VSSOP Packaging (3.0 x 5.0 x 1.09mm)
- WEBENCH® Enabled

PERFORMANCE BENEFITS

- Extremely Easy to Use
- Tiny Overall Solution Reduces System Cost

APPLICATIONS

- Boost/SEPIC Conversions from 3.3V, 5V, and 12V
- Space Constrained Applications
- LCD Displays
- LED Applications

System Performance

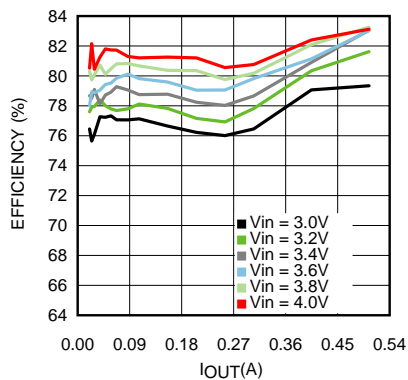
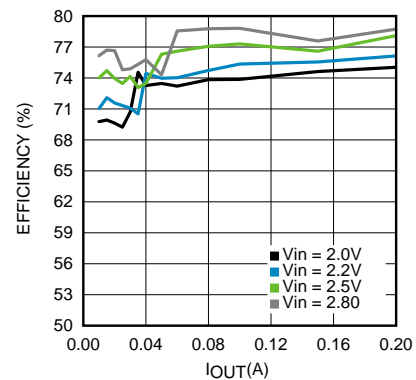
 Efficiency vs Load Current, V_{OUT} = 5V

 Efficiency vs Load Current, V_{OUT} = 3.3V

Please be aware that an important notice concerning availability, standard warranty, and use in critical applications of Texas Instruments semiconductor products and disclaimers thereto appears at the end of this data sheet.

SIMPLE SWITCHER, WEBENCH are registered trademarks of Texas Instruments.
All other trademarks are the property of their respective owners.

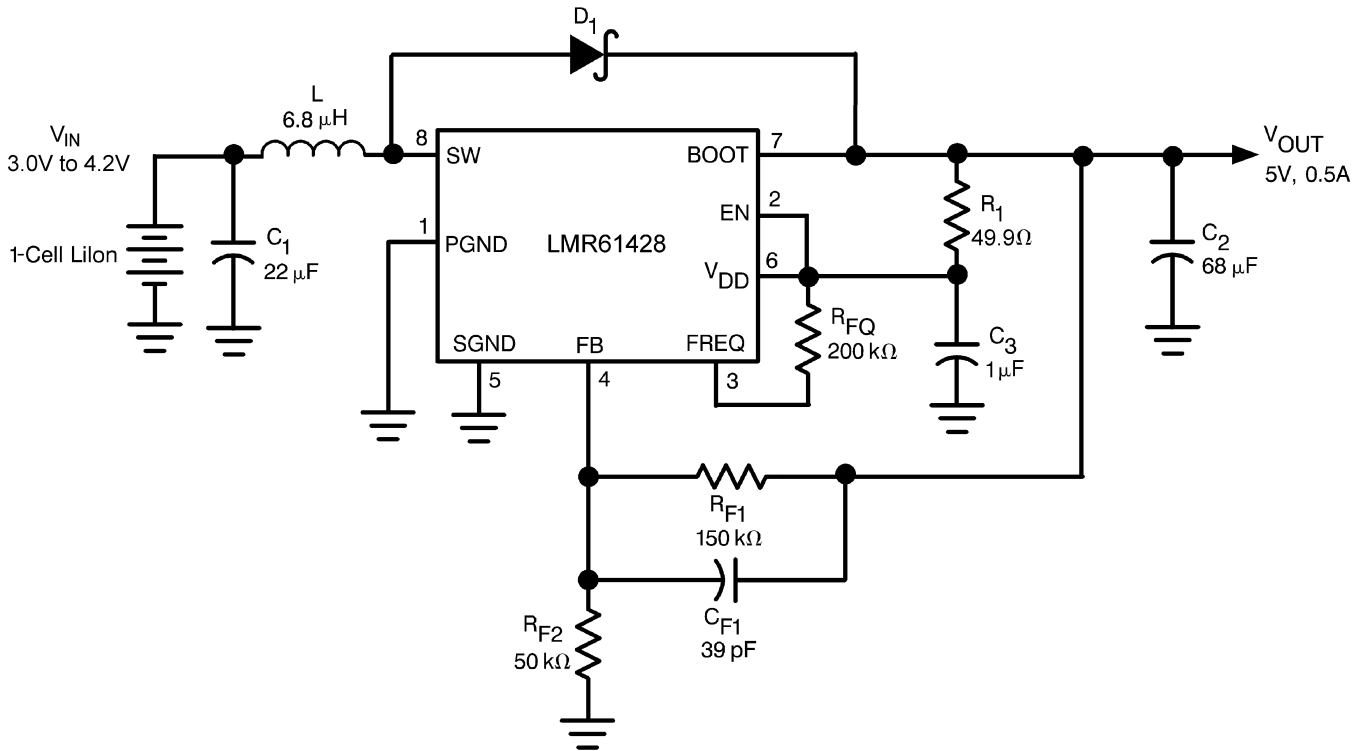
Typical Application Circuit



Connection Diagram

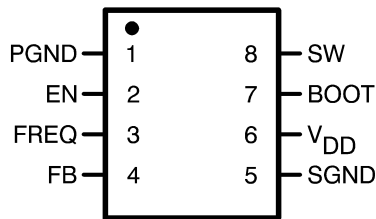

VSSOP Package (Top View)
See Package Number DGK

PIN DESCRIPTION

Pin	Name	Function
1	PGND	Power Ground
2	EN	Active-Low Shutdown Input
3	FREQ	Frequency Adjust. An external resistor connected between this pin and Pin 6 (V_{DD}) sets the switching frequency of the LMR61428.
4	FB	Output Voltage Feedback
5	SGND	Signal Ground
6	V_{DD}	Power Supply for Internal Circuitry
7	BOOT	Bootstrap Supply for the Gate Drive of Internal MOSFET Power Switch
8	SW	Drain of the Internal MOSFET Power Switch



These devices have limited built-in ESD protection. The leads should be shorted together or the device placed in conductive foam during storage or handling to prevent electrostatic damage to the MOS gates.

Absolute Maximum Ratings⁽¹⁾⁽²⁾

SW Pin Voltage	-0.5 V to 14.5V
BOOT, V _{DD} , EN and FB Pins	-0.5V to 10V
FREQ Pin	100µA
θ _{JA} ⁽³⁾	240°C/W
T _{Jmax} ⁽³⁾	150°C
Storage Temperature Range	-65°C to +150°C
Lead Temp. (Soldering, 5 sec)	260°C
Power Dissipation (T _A =25°C) ⁽³⁾	500mW
ESD Rating ⁽⁴⁾	2kV

- (1) Absolute maximum ratings indicate limits beyond which damage to the device may occur. Electrical specifications do not apply when operating the device outside of its rated operating conditions.
- (2) If Military/Aerospace specified devices are required, please contact the Texas Instruments Sales Office/ Distributors for availability and specifications.
- (3) The maximum power dissipation must be derated at elevated temperatures and is dictated by T_{Jmax} (maximum junction temperature), θ_{JA} (junction to ambient thermal resistance), and T_A (ambient temperature). The maximum allowable power dissipation at any temperature is P_{dmax} = (T_{Jmax} - T_A) / θ_{JA} or the number given in the [Absolute Maximum Ratings](#), whichever is lower.
- (4) The human body model is a 100 pF capacitor discharged through a 1.5 kΩ resistor into each pin. For Pin 8 (SW) the ESD rating is 1.5 kV.

Operating Conditions⁽¹⁾

V _{DD} Pin	2.5V to 5V
FB, EN Pins	0 to V _{DD}
BOOT Pin	0 to 10V
Ambient Temperature (T _A)	-40°C to +85°C

- (1) Absolute maximum ratings indicate limits beyond which damage to the device may occur. Electrical specifications do not apply when operating the device outside of its rated operating conditions.

Electrical Characteristics

Limits in standard typeface are for $T_J = 25^\circ\text{C}$, and limits in **boldface** type apply over the full operating temperature range of -40°C to $+85^\circ\text{C}$. Unless otherwise specified: $V_{DD} = V_{OUT} = 3.3\text{V}$.

Symbol	Parameter	Condition	Min	Typ	Max	Units
V_{IN_ST}	Minimum Start-Up Supply Voltage ⁽¹⁾	$I_{LOAD} = 0\text{mA}$		1.1	1.2	V
V_{IN_OP}	Minimum Operating Supply Voltage (once started)	$I_{LOAD} = 0\text{mA}$		0.65		V
V_{FB}	FB Pin Voltage		1.2028	1.24	1.2772	V
V_{OUT_MAX}	Maximum Output Voltage			14		V
V_{HYST}	Hysteresis Voltage ⁽²⁾	At Feedback Pin		30	45	mV
η	Efficiency	$V_{IN} = 3.6\text{V}; V_{OUT} = 5\text{V}; I_{LOAD} = 0.5\text{A}$		87		%
		$V_{IN} = 2.5\text{V}; V_{OUT} = 3.3\text{V}; I_{LOAD} = 0.2\text{A}$		87		
D	Switch Duty Cycle		60	70	80	%
I_{DD}	Operating Quiescent Current ⁽³⁾	FB Pin > 1.3V; EN Pin at V_{DD}		80	110	μA
I_{SD}	Shutdown Quiescent Current ⁽⁴⁾	V_{DD} , BOOT and SW Pins at 5.0V; EN Pin < 200mV		0.01	2.5	μA
I_{CL}	Switch Peak Current Limit			2.85		A
R_{DS_ON}	MOSFET Switch On Resistance			0.17		Ω
Enable Section						
V_{EN_LO}	EN Pin Voltage Low ⁽⁵⁾				$0.15V_{DD}$	V
V_{EN_HI}	EN Pin Voltage High ⁽⁵⁾		$0.7V_{DD}$			V

(1) Output in regulation, $V_{OUT} = V_{OUT(NOMINAL)} \pm 5\%$

(2) This is the hysteresis value of the internal comparator used for the gated-oscillator control scheme.

(3) This is the current into the V_{DD} pin.

(4) This is the total current into pins V_{DD} , BOOT, SW and FREQ.

(5) When the EN pin is below V_{EN_LO} , the regulator is shut down; when it is above V_{EN_HI} , the regulator is operating.

TYPICAL PERFORMANCE CHARACTERISTICS

All curves taken at $T_A = 25^\circ\text{C}$, unless specified otherwise.

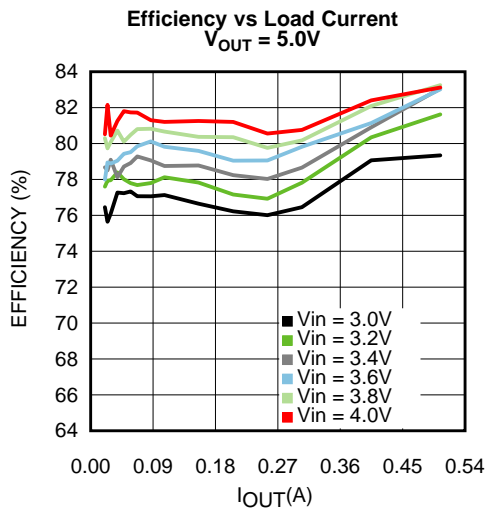

Figure 1.

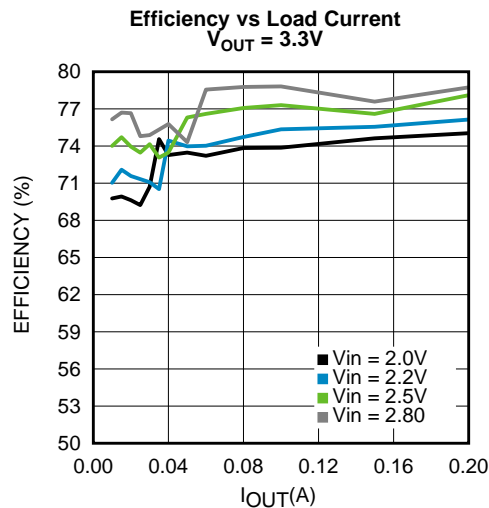

Figure 2.

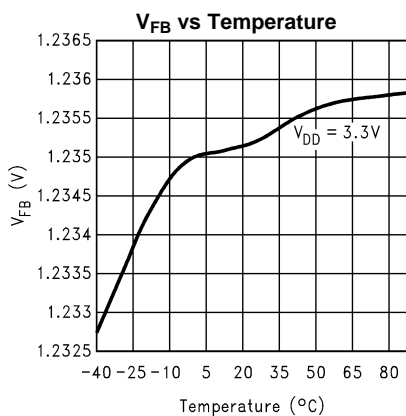

Figure 3.

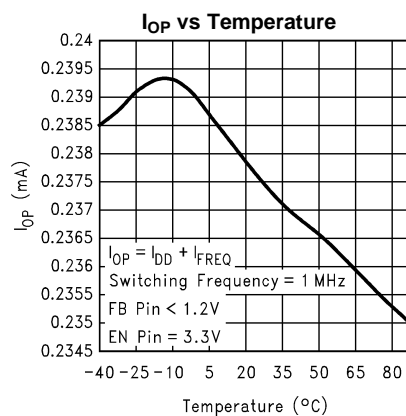

Figure 4.

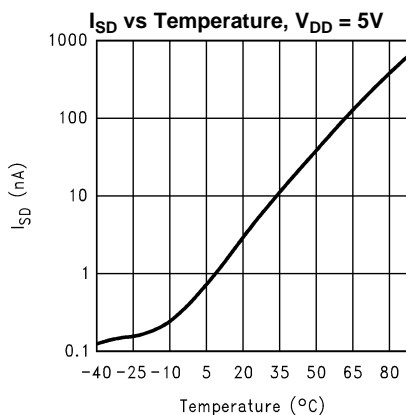

Figure 5.

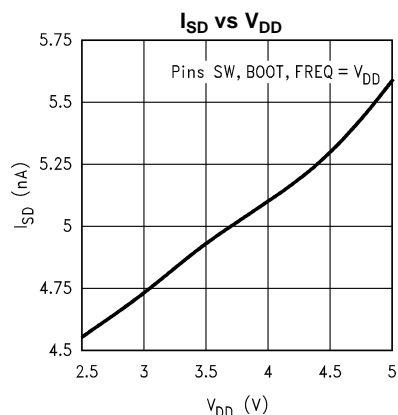

Figure 6.

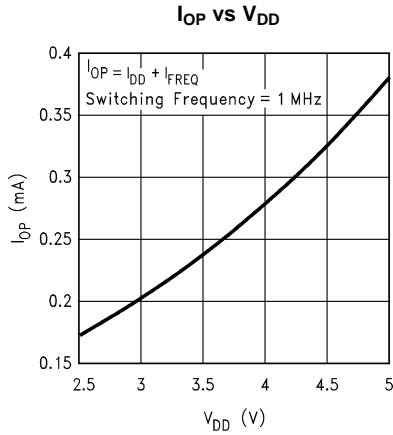

Figure 7.

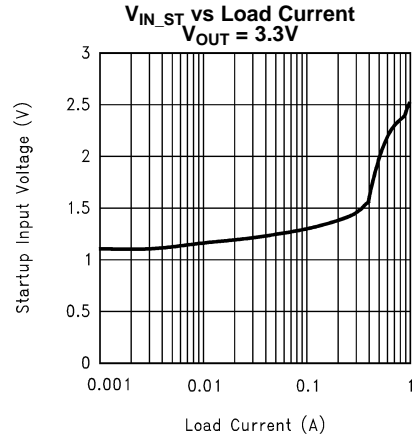

Figure 8.

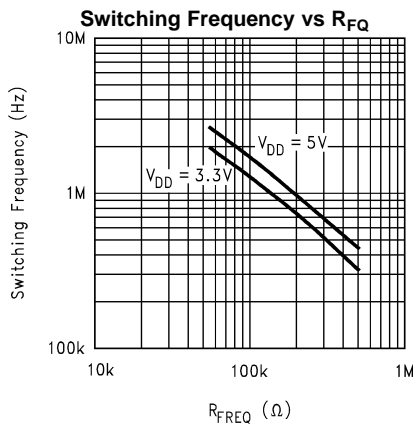

Figure 9.

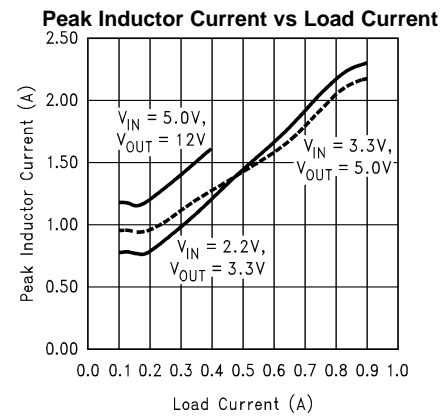

Figure 10.

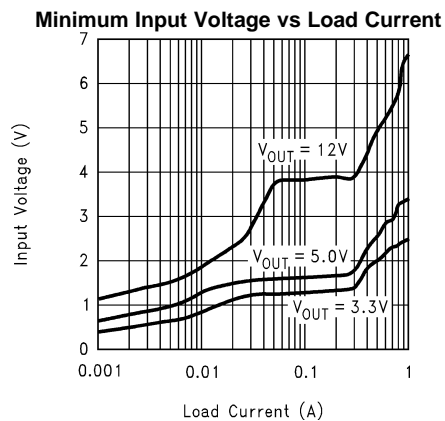

Figure 11.

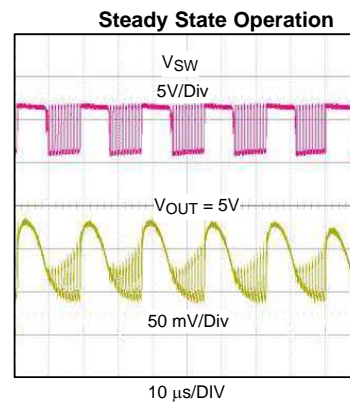

Figure 12.

Simplified Block Diagram

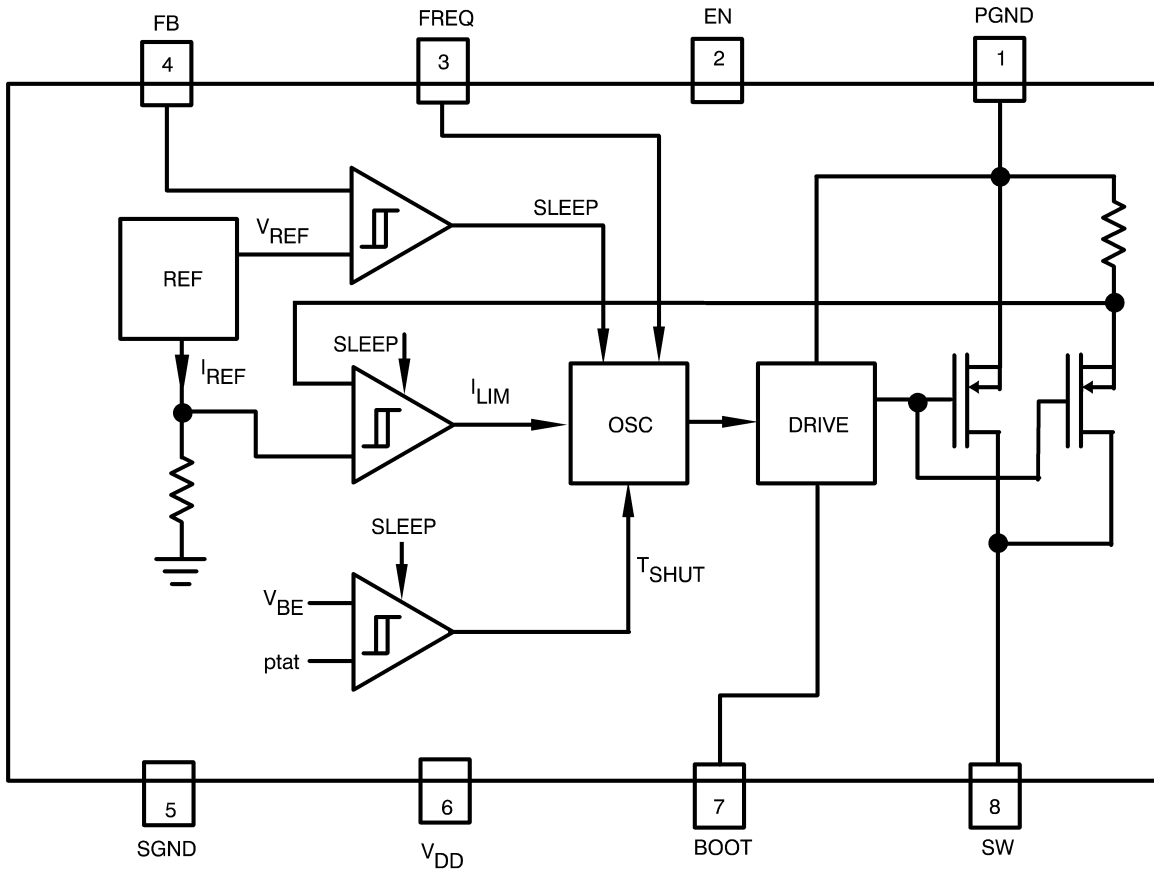

Figure 13. Block Diagram

DETAILED DESCRIPTION

OPERATING PRINCIPLE

The LMR61428 is designed to provide step-up DC-DC voltage regulation in battery-powered and low-input voltage systems. It combines a step-up switching regulator, N-channel power MOSFET, built-in current limit, thermal limit, and voltage reference in a single 8-pin VSSOP package. The switching DC-DC regulator boosts an input voltage between 1.2V and 14V to a regulated output voltage between 1.24V and 14V that is limited by a fixed maximum duty cycle of 70%. The LMR61428 starts from a low 1.1V input and remains operational down to 0.65V.

This device is optimized for use in cellular phones and other applications requiring a small size, low profile, as well as low quiescent current for maximum battery life during stand-by and shutdown. A high-efficiency gated-oscillator topology offers an output of up to 1A.

Additional features include a built-in peak switch current limit, and thermal protection circuitry.

GATED OSCILLATOR CONTROL SCHEME

A unique gated oscillator control scheme enables the LMR61428 to have an ultra-low quiescent current and provides a high efficiency over a wide load range. The switching frequency of the internal oscillator is programmable using an external resistor and can be set between 300 kHz and 2 MHz.

This control scheme uses a hysteresis window to regulate the output voltage. When the output voltage is below the upper threshold of the window, the LMR61428 switches continuously with a fixed duty cycle of 70% at the switching frequency selected by the user. During the first part of each switching cycle, the internal N-channel MOSFET switch is turned on. This causes the current to ramp up in the inductor and store energy. During the second part of each switching cycle, the MOSFET is turned off. The voltage across the inductor reverses and forces current through the diode to the output filter capacitor and the load. Thus when the LMR61428 switches continuously, the output voltage starts to ramp up. When the output voltage hits the upper threshold of the window, the LMR61428 stops switching completely. This causes the output voltage to droop because the energy stored in the output capacitor is depleted by the load. When the output voltage hits the lower threshold of the hysteresis window, the LMR61428 starts switching continuously again causing the output voltage to ramp up towards the upper threshold. Figure 14 shows the switch voltage and output voltage waveforms.

Because of this type of control scheme, the quiescent current is inherently very low. At light loads the gated oscillator control scheme offers a much higher efficiency compared to the conventional PWM control scheme.

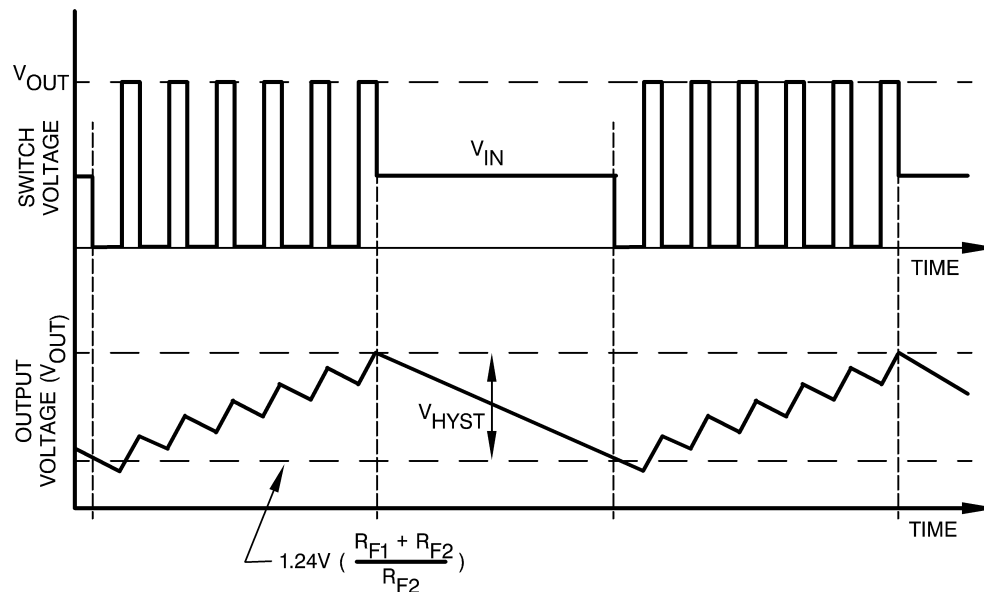

Figure 14. Typical Step-Up Regulator Waveforms

LOW VOLTAGE START-UP

The LMR61428 can start-up from input voltages as low as 1.1V. On start-up, the control circuitry switches the N-channel MOSFET continuously at 70% duty cycle until the output voltage reaches 2.5V. After this output voltage is reached, the normal step-up regulator feedback and gated oscillator control scheme take over. Once the device is in regulation it can operate down to a 0.65V input, since the internal power for the IC can be bootstrapped from the output using the V_{DD} pin.

SHUTDOWN

The LMR61428 features a shutdown mode that reduces the quiescent current to less than an ensured 2.5 μ A over temperature. This extends the life of the battery in battery powered applications. During shutdown, all feedback and control circuitry is turned off. The regulator's output voltage drops to one diode drop below the input voltage. Entry into the shutdown mode is controlled by the active-low logic input pin EN (Pin 2). When the logic input to this pin pulled below 0.15 V_{DD} , the device goes into shutdown mode. The logic input to this pin should be above 0.7 V_{DD} for the device to work in normal step-up mode.

OUTPUT VOLTAGE RIPPLE FREQUENCY

A major component of the output voltage ripple is due to the hysteresis used in the gated oscillator control scheme. The frequency of this voltage ripple is proportional to the load current. The frequency of this ripple does not necessitate the use of larger inductors and capacitors. The size of these components is determined by the switching frequency of the oscillator which can be set upto 2MHz using an external resistor.

INTERNAL CURRENT LIMIT AND THERMAL PROTECTION

An internal cycle-by-cycle current limit serves as a protection feature. This is set high enough (2.85A typical, approximately 4A maximum) so as not to come into effect during normal operating conditions. An internal thermal protection circuitry disables the MOSFET power switch when the junction temperature (T_J) exceeds about 160°C. The switch is re-enabled when T_J drops below approximately 135°C.

Design Procedure

SETTING THE OUTPUT VOLTAGE

The output voltage of the step-up regulator can be set between 1.24V and 14V. But because of the gated oscillator scheme, the maximum possible input to output boost ratio is fixed. For a boost regulator,

$$V_{OUT} / V_{IN} = 1 / [1-D] \quad (1)$$

The LMR61428 has a fixed duty cycle, D, of 70% typical. Therefore,

$$V_{OUT} / V_{IN} = 1 / 0.3 \quad (2)$$

This sets the maximum possible boost ratio of V_{IN} to V_{OUT} to about 3 times. The user can now estimate what the minimum design inputs should be in order to achieve a desired output, or what the output would be when a certain minimum input is applied. E.g. If the desired V_{OUT} was 14V, then the least V_{IN} should be higher than $V_{OUT} / 3$. If the input voltage fell below this threshold, the output voltage would not be regulated because of the fixed duty cycle. If the minimum V_{IN} was ensured at 2V, the max possible V_{OUT} would be $V_{IN} * 3$.

The V_{OUT} is set by connecting a feedback resistive divider made of R_{F1} and R_{F2} . The feedback resistor values are selected as follows:

$$R_{F2} = R_{F1} / [(V_{OUT} / 1.24) - 1] \quad (3)$$

A value of 150k Ω is suggested for R_{F1} . Then, R_{F2} can be selected using the above equation. A 39pF capacitor (C_{ff}) connected across R_{F1} helps in feeding back most of the AC ripple at V_{OUT} to the FB pin. This helps reduce the peak-to-peak output voltage ripple as well as improve the efficiency of the step-up regulator, because a set hysteresis of 30mV at the FB pin is used for the gated oscillator control scheme.

BOOTSTRAPPING

When the output voltage (V_{OUT}) is between 2.5V and 5.0V a bootstrapped operation is suggested. This is achieved by connecting the V_{DD} pin (Pin 6) to V_{OUT} . However if the V_{OUT} is outside this range, the V_{DD} pin should be connected to a voltage source whose range is between 2.5V and 5V. This can be the input voltage (V_{IN}), V_{OUT} stepped down using a linear regulator, or a different voltage source available in the system. This is referred to as non-bootstrapped operation. The maximum acceptable voltage at the BOOT pin (Pin 7) is 10V.

SETTING THE SWITCHING FREQUENCY

The switching frequency of the oscillator is selected by choosing an external resistor (R_{FQ}) connected between FREQ and V_{DD} pins. See the following graph, [Figure 15](#), for choosing the R_{FQ} value to achieve the desired switching frequency. A high switching frequency allows the use of very small surface mount inductors and capacitors and results in a very small solution size. A switching frequency between 300kHz and 2MHz is recommended.

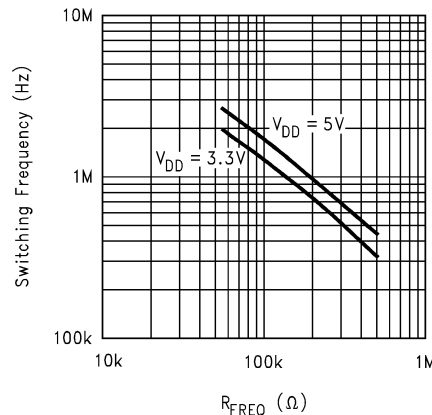

Figure 15. Switching Frequency vs R_{FQ}

INDUCTOR SELECTION

The LMR61428's high switching frequency enables the use of a small surface mount inductor. A 6.8 μ H shielded inductor is suggested for a typical application. The inductor should have a saturation current rating higher than the peak current it will experience during circuit operation (see the following graph, [Peak Inductor vs Load Current](#)). Less than 100m Ω ESR is suggested for high efficiency.

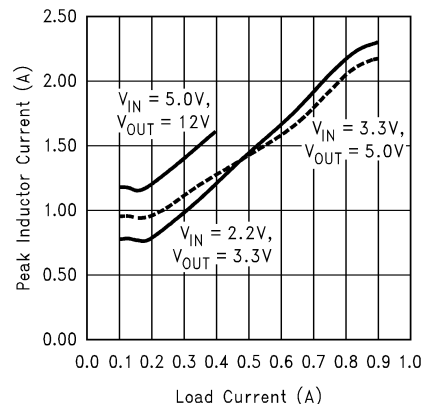

Figure 16. Peak Inductor Current vs Load Current

Open-core inductors cause flux linkage with circuit components and interfere with the normal operation of the circuit. They should be avoided. For high efficiency, choose an inductor with a high frequency core material, such as ferrite, to reduce the core losses. To minimize radiated noise, use a toroid, pot core or shielded core inductor. The inductor should be connected to the SW pin as close to the IC as possible. See [Connection Diagram](#).

OUTPUT DIODE SELECTION

A Schottky diode should be used for the output diode. The forward current rating of the diode should be higher than the load current, and the reverse voltage rating must be higher than the output voltage. Do not use ordinary rectifier diodes, since slow switching speeds and long recovery times cause the efficiency and the load regulation to suffer.

INPUT AND OUTPUT FILTER CAPACITORS SELECTION

While tantalum chip capacitors are recommended for the input and output filter capacitors, ceramic caps can also be used. A 22 μ F capacitor is suggested for the input filter capacitor. It should have a DC working voltage rating higher than the maximum input voltage. A 68 μ F tantalum capacitor is suggested for the output capacitor. The DC working voltage rating should be greater than the output voltage. Very high ESR values (>3 Ω) should be avoided.

PC BOARD LAYOUT

High switching frequencies and high peak currents make a proper layout of the PC board an important part of design. Poor design can cause excessive EMI and ground-bounce, both of which can cause malfunction and loss of regulation by corrupting voltage feedback signal and injecting noise into the control section.

Power components - such as the inductor, input and output filter capacitors, and output diode - should be placed as close to the regulator IC as possible, and their traces should be kept short, direct and wide. The ground pins of the input and output filter capacitors and the PGND and SGND pins of LMR61428 should be connected using short, direct and wide traces. The voltage feedback network (R_{fbt} , R_{fbb} , and C_{ff}) should be kept very close to the FB pin. Noisy traces, such as from the SW pin, should be kept away from the FB and V_{DD} pins. The traces that run between V_{out} and the FB pin of the IC should be kept away from the inductor flux. Always provide sufficient copper area to dissipate the heat due to power loss in the circuitry and prevent the thermal protection circuitry in the IC from shutting the IC down. Additional ground planes at intermediate levels help with shielding and improve EMI mitigation.

Application Examples

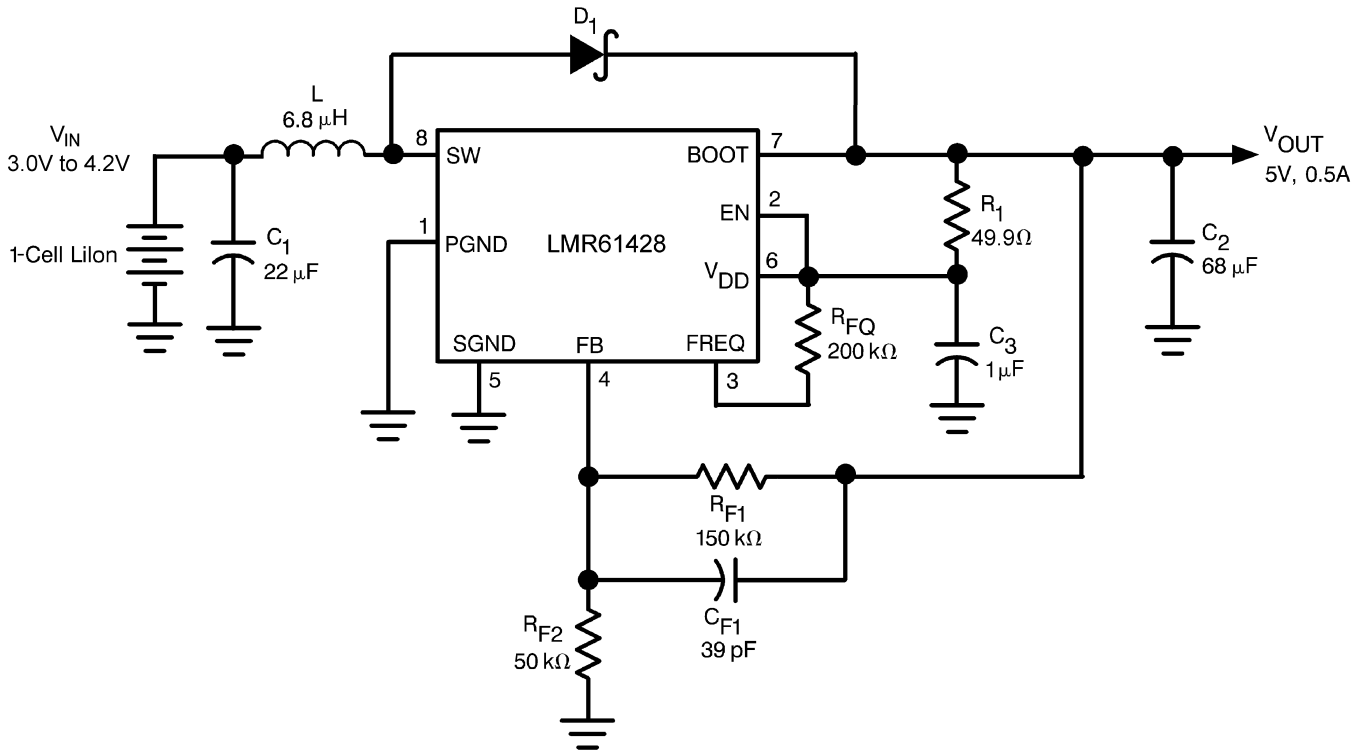

Figure 17. EXAMPLE 1. 5V/0.5A Step-Up Regulator

U1	Texas Instruments	LMR61428XMM
C1	Vishay/Sprague	595D226X06R3B2T, Tantalum
C2	Vishay/Sprague	595D686X0010C2T, Tantalum
D1	Motorola	MBRS140T3
L	Coilcraft	DT1608C-682

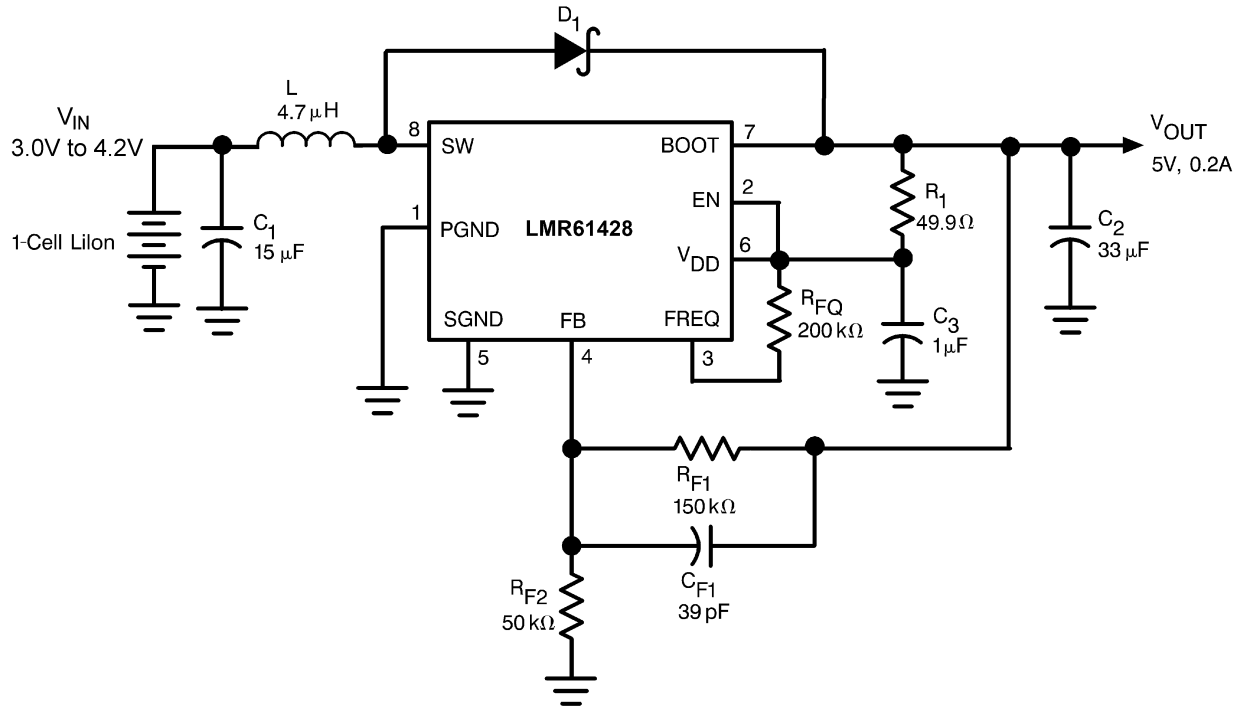

Figure 18. EXAMPLE 2. 2mm Tall 5V/0.2A Step-Up Regulator for Low Profile Applications

U1	Texas Instruments	LMR61428XMM
C1	Vishay/Sprague	592D156X06R3B2T, Tantalum
C2	Vishay/Sprague	592D336X06R3C2T, Tantalum
D1	Motorola	MBRS140T3
L	Vishay/Dale	ILS-3825-03

REVISION HISTORY

Changes from Original (April 2013) to Revision A	Page
• Changed layout of National Data Sheet to TI format	13

PACKAGING INFORMATION

Orderable Device	Status (1)	Package Type	Package Drawing	Pins	Package Qty	Eco Plan (2)	Lead/Ball Finish (6)	MSL Peak Temp (3)	Op Temp (°C)	Device Marking (4/5)	Samples
LMR61428XMM/NOPB	ACTIVE	VSSOP	DGK	8	1000	Green (RoHS & no Sb/Br)	CU SN	Level-1-260C-UNLIM	-40 to 85	SN1B	Samples
LMR61428XMMX/NOPB	ACTIVE	VSSOP	DGK	8	3500	Green (RoHS & no Sb/Br)	CU SN	Level-1-260C-UNLIM	-40 to 85	SN1B	Samples

(1) The marketing status values are defined as follows:

ACTIVE: Product device recommended for new designs.

LIFEBUY: TI has announced that the device will be discontinued, and a lifetime-buy period is in effect.

NRND: Not recommended for new designs. Device is in production to support existing customers, but TI does not recommend using this part in a new design.

PREVIEW: Device has been announced but is not in production. Samples may or may not be available.

OBSOLETE: TI has discontinued the production of the device.

(2) Eco Plan - The planned eco-friendly classification: Pb-Free (RoHS), Pb-Free (RoHS Exempt), or Green (RoHS & no Sb/Br) - please check <http://www.ti.com/productcontent> for the latest availability information and additional product content details.

TBD: The Pb-Free/Green conversion plan has not been defined.

Pb-Free (RoHS): TI's terms "Lead-Free" or "Pb-Free" mean semiconductor products that are compatible with the current RoHS requirements for all 6 substances, including the requirement that lead not exceed 0.1% by weight in homogeneous materials. Where designed to be soldered at high temperatures, TI Pb-Free products are suitable for use in specified lead-free processes.

Pb-Free (RoHS Exempt): This component has a RoHS exemption for either 1) lead-based flip-chip solder bumps used between the die and package, or 2) lead-based die adhesive used between the die and leadframe. The component is otherwise considered Pb-Free (RoHS compatible) as defined above.

Green (RoHS & no Sb/Br): TI defines "Green" to mean Pb-Free (RoHS compatible), and free of Bromine (Br) and Antimony (Sb) based flame retardants (Br or Sb do not exceed 0.1% by weight in homogeneous material)

(3) MSL, Peak Temp. - The Moisture Sensitivity Level rating according to the JEDEC industry standard classifications, and peak solder temperature.

(4) There may be additional marking, which relates to the logo, the lot trace code information, or the environmental category on the device.

(5) Multiple Device Markings will be inside parentheses. Only one Device Marking contained in parentheses and separated by a "~" will appear on a device. If a line is indented then it is a continuation of the previous line and the two combined represent the entire Device Marking for that device.

(6) Lead/Ball Finish - Orderable Devices may have multiple material finish options. Finish options are separated by a vertical ruled line. Lead/Ball Finish values may wrap to two lines if the finish value exceeds the maximum column width.

Important Information and Disclaimer: The information provided on this page represents TI's knowledge and belief as of the date that it is provided. TI bases its knowledge and belief on information provided by third parties, and makes no representation or warranty as to the accuracy of such information. Efforts are underway to better integrate information from third parties. TI has taken and continues to take reasonable steps to provide representative and accurate information but may not have conducted destructive testing or chemical analysis on incoming materials and chemicals. TI and TI suppliers consider certain information to be proprietary, and thus CAS numbers and other limited information may not be available for release.

In no event shall TI's liability arising out of such information exceed the total purchase price of the TI part(s) at issue in this document sold by TI to Customer on an annual basis.

TAPE AND REEL INFORMATION



QUADRANT ASSIGNMENTS FOR PIN 1 ORIENTATION IN TAPE



*All dimensions are nominal

Device	Package Type	Package Drawing	Pins	SPQ	Reel Diameter (mm)	Reel Width W1 (mm)	A0 (mm)	B0 (mm)	K0 (mm)	P1 (mm)	W (mm)	Pin1 Quadrant
LMR61428XMM/NOPB	VSSOP	DGK	8	1000	178.0	12.4	5.3	3.4	1.4	8.0	12.0	Q1
LMR61428XMMX/NOPB	VSSOP	DGK	8	3500	330.0	12.4	5.3	3.4	1.4	8.0	12.0	Q1

TAPE AND REEL BOX DIMENSIONS

*All dimensions are nominal

Device	Package Type	Package Drawing	Pins	SPQ	Length (mm)	Width (mm)	Height (mm)
LMR61428XMM/NOPB	VSSOP	DGK	8	1000	210.0	185.0	35.0
LMR61428XMMX/NOPB	VSSOP	DGK	8	3500	367.0	367.0	35.0

DGK (S-PDSO-G8)

PLASTIC SMALL-OUTLINE PACKAGE



4073329/E 05/06

- NOTES:
- A. All linear dimensions are in millimeters.
 - B. This drawing is subject to change without notice.
 - C. Body length does not include mold flash, protrusions, or gate burrs. Mold flash, protrusions, or gate burrs shall not exceed 0.15 per end.
 - D. Body width does not include interlead flash. Interlead flash shall not exceed 0.50 per side.
 - E. Falls within JEDEC MO-187 variation AA, except interlead flash.



- NOTES:
- A. All linear dimensions are in millimeters.
 - B. This drawing is subject to change without notice.
 - C. Publication IPC-7351 is recommended for alternate designs.
 - D. Laser cutting apertures with trapezoidal walls and also rounding corners will offer better paste release. Customers should contact their board assembly site for stencil design recommendations. Refer to IPC-7525 for other stencil recommendations.
 - E. Customers should contact their board fabrication site for solder mask tolerances between and around signal pads.

IMPORTANT NOTICE

Texas Instruments Incorporated and its subsidiaries (TI) reserve the right to make corrections, enhancements, improvements and other changes to its semiconductor products and services per JESD46, latest issue, and to discontinue any product or service per JESD48, latest issue. Buyers should obtain the latest relevant information before placing orders and should verify that such information is current and complete. All semiconductor products (also referred to herein as "components") are sold subject to TI's terms and conditions of sale supplied at the time of order acknowledgment.

TI warrants performance of its components to the specifications applicable at the time of sale, in accordance with the warranty in TI's terms and conditions of sale of semiconductor products. Testing and other quality control techniques are used to the extent TI deems necessary to support this warranty. Except where mandated by applicable law, testing of all parameters of each component is not necessarily performed.

TI assumes no liability for applications assistance or the design of Buyers' products. Buyers are responsible for their products and applications using TI components. To minimize the risks associated with Buyers' products and applications, Buyers should provide adequate design and operating safeguards.

TI does not warrant or represent that any license, either express or implied, is granted under any patent right, copyright, mask work right, or other intellectual property right relating to any combination, machine, or process in which TI components or services are used. Information published by TI regarding third-party products or services does not constitute a license to use such products or services or a warranty or endorsement thereof. Use of such information may require a license from a third party under the patents or other intellectual property of the third party, or a license from TI under the patents or other intellectual property of TI.

Reproduction of significant portions of TI information in TI data books or data sheets is permissible only if reproduction is without alteration and is accompanied by all associated warranties, conditions, limitations, and notices. TI is not responsible or liable for such altered documentation. Information of third parties may be subject to additional restrictions.

Resale of TI components or services with statements different from or beyond the parameters stated by TI for that component or service voids all express and any implied warranties for the associated TI component or service and is an unfair and deceptive business practice. TI is not responsible or liable for any such statements.

Buyer acknowledges and agrees that it is solely responsible for compliance with all legal, regulatory and safety-related requirements concerning its products, and any use of TI components in its applications, notwithstanding any applications-related information or support that may be provided by TI. Buyer represents and agrees that it has all the necessary expertise to create and implement safeguards which anticipate dangerous consequences of failures, monitor failures and their consequences, lessen the likelihood of failures that might cause harm and take appropriate remedial actions. Buyer will fully indemnify TI and its representatives against any damages arising out of the use of any TI components in safety-critical applications.

In some cases, TI components may be promoted specifically to facilitate safety-related applications. With such components, TI's goal is to help enable customers to design and create their own end-product solutions that meet applicable functional safety standards and requirements. Nonetheless, such components are subject to these terms.

No TI components are authorized for use in FDA Class III (or similar life-critical medical equipment) unless authorized officers of the parties have executed a special agreement specifically governing such use.

Only those TI components which TI has specifically designated as military grade or "enhanced plastic" are designed and intended for use in military/aerospace applications or environments. Buyer acknowledges and agrees that any military or aerospace use of TI components which have **not** been so designated is solely at the Buyer's risk, and that Buyer is solely responsible for compliance with all legal and regulatory requirements in connection with such use.

TI has specifically designated certain components as meeting ISO/TS16949 requirements, mainly for automotive use. In any case of use of non-designated products, TI will not be responsible for any failure to meet ISO/TS16949.

Products

Audio	www.ti.com/audio
Amplifiers	amplifier.ti.com
Data Converters	dataconverter.ti.com
DLP® Products	www.dlp.com
DSP	dsp.ti.com
Clocks and Timers	www.ti.com/clocks
Interface	interface.ti.com
Logic	logic.ti.com
Power Mgmt	power.ti.com
Microcontrollers	microcontroller.ti.com
RFID	www.ti-rfid.com
OMAP Applications Processors	www.ti.com/omap
Wireless Connectivity	www.ti.com/wirelessconnectivity

Applications

Automotive and Transportation	www.ti.com/automotive
Communications and Telecom	www.ti.com/communications
Computers and Peripherals	www.ti.com/computers
Consumer Electronics	www.ti.com/consumer-apps
Energy and Lighting	www.ti.com/energy
Industrial	www.ti.com/industrial
Medical	www.ti.com/medical
Security	www.ti.com/security
Space, Avionics and Defense	www.ti.com/space-avionics-defense
Video and Imaging	www.ti.com/video

TI E2E Community

e2e.ti.com