

## LMK01801 Dual Clock Divider Buffer

Check for Samples: [LMK01801](#)

### 1 Device Summary

#### 1.1 Features

- Pin Control Mode or MICROWIRE (SPI)
- Input and Output Frequency Range 1 kHz to 3.1 GHz
- Separate Input for Clock Output Banks A & B.
- 14 Differential Clock Outputs in Two Banks (A & B)
  - Output Bank A
    - 8 Differential, Programmable Outputs (Up to 8 as LVCMOS)
    - Divider Values of 1 to 8, Even and Odd.
  - Output Bank B
    - 6 Differential Outputs (or up to 12 as LVCMOS)
    - Divides Values of 1 to 1045 or 1 to 8, Even and Odd
    - Analog and Digital Delays
- 50% Duty Cycle on All Outputs for All Divides
- Separate Synchronization of Bank A and B.
- RMS Additive Jitter 50 fs at 800 MHz
  - 50 fs RMS Additive Jitter (12 kHz to 20 MHz)
- Industrial Temperature Range: -40 to 85 °C
- 3.15 V to 3.45 V Operation

#### 1.2 Target Applications

- High Performance Clock Distribution and Division
- Wireless Infrastructure
- Datacom and Telecom Clock Distribution
- Medical Imaging
- Test and Measurement
- Military / Aerospace

#### 1.3 Description

The LMK01801 is a very low noise solution for clocking systems that require distribution and frequency division of precision clocks.

The LMK01801 features extremely low residual noise, frequency division, digital and analog delay adjustments, and fourteen (14) programmable differential outputs: LVPECL, LVDS and LVCMOS (2 outputs per differential output).

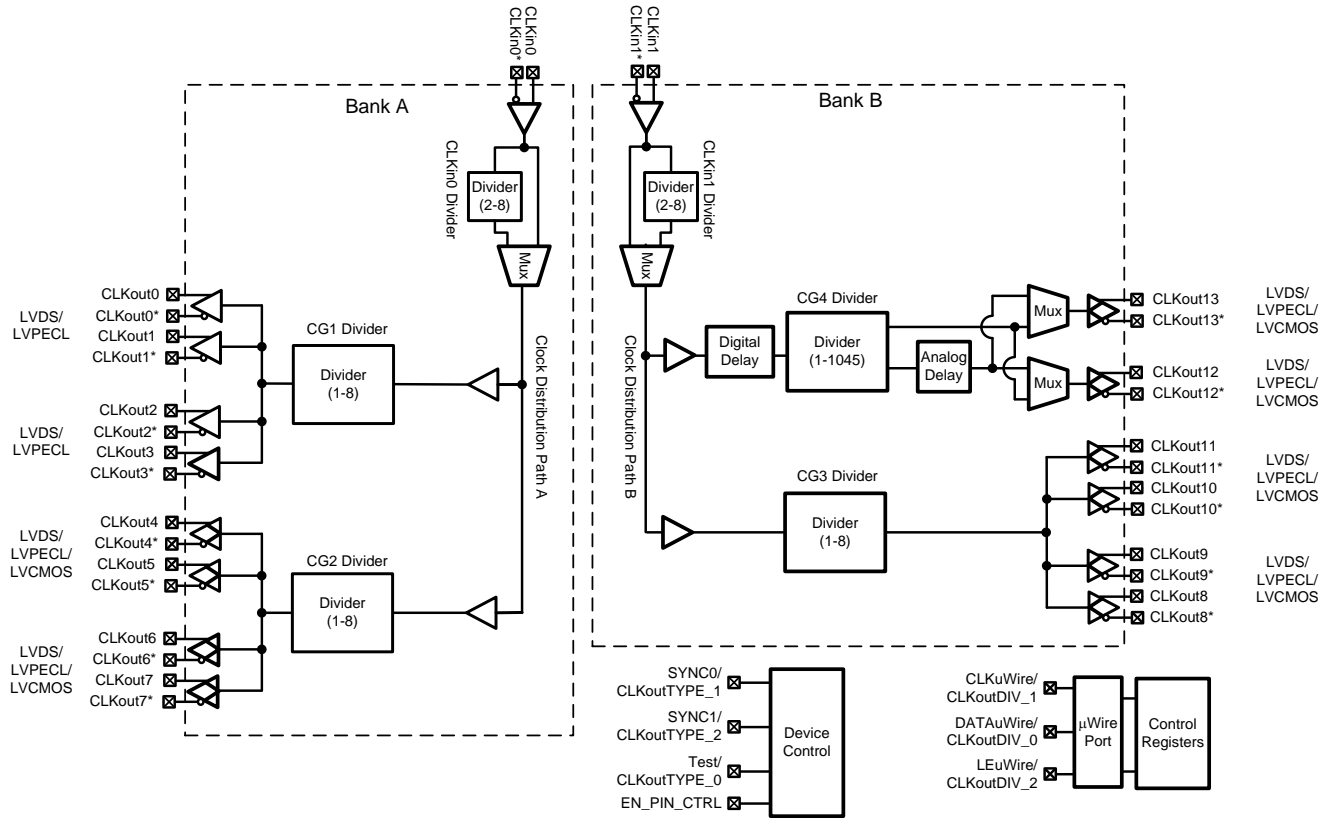
The LMK01801 features two independent inputs that can be driven differentially (LVDS, LVPECL) or in single-ended mode (LVCMOS, RF Sinewave). The first input drives output Bank A consisting of eight (8) outputs. The second input drives output Bank B consisting of six (6) outputs.



Please be aware that an important notice concerning availability, standard warranty, and use in critical applications of Texas Instruments semiconductor products and disclaimers thereto appears at the end of this data sheet.

All trademarks are the property of their respective owners.

### 1.4 Functional Block Diagram



|          |   |                           |                         |   |                           |
|----------|---|---------------------------|-------------------------|---|---------------------------|
| <b>1</b> | <b>Device Summary</b>                                       | <b><a href="#">1</a></b>  | 6.9                     | CLOCK OUTPUT SYNCHRONIZATION                          | <a href="#">15</a>        |
| 1.1      | Features  | <a href="#">1</a>         | 6.10                    | DEFAULT CLOCK OUTPUTS                                 | <a href="#">15</a>        |
| 1.2      | Target Applications   | <a href="#">1</a>         | <b>7</b>                | <b>Functional Description</b>                         | <b><a href="#">16</a></b> |
| 1.3      | Description   | <a href="#">1</a>         | 7.1                     | PROGRAMMABLE MODE                                     | <a href="#">16</a>        |
| 1.4      | Functional Block Diagram                                    | <a href="#">2</a>         | 7.2                     | PIN CONTROL MODE                                      | <a href="#">16</a>        |
| <b>2</b> | <b>Device Information</b>                                   | <b><a href="#">4</a></b>  | 7.3                     | INPUTS / OUTPUTS                                      | <a href="#">16</a>        |
| 2.1      | Functional Configurations                                   | <a href="#">4</a>         | 7.4                     | INPUT AND OUTPUT DIVIDERS                             | <a href="#">16</a>        |
| 2.2      | Connection Diagram  | <a href="#">5</a>         | 7.5                     | FIXED DIGITAL DELAY                                   | <a href="#">16</a>        |
| <b>3</b> | <b>Electrical Specifications</b>                            | <b><a href="#">7</a></b>  | 7.6                     | CLOCK OUTPUT SYNCHRONIZATION (SYNC)                   | <a href="#">18</a>        |
| 3.1      | Absolute Maximum Ratings                                    | <a href="#">7</a>         | <b>8</b>                | <b>General Programming Information</b>                | <b><a href="#">26</a></b> |
| 3.2      | Package Thermal Resistance                                  | <a href="#">7</a>         | 8.1                     | RECOMMENDED PROGRAMMING SEQUENCE                      | <a href="#">26</a>        |
| 3.3      | Recommended Operating Conditions                            | <a href="#">7</a>         | 8.2                     | REGISTER MAP  | <a href="#">27</a>        |
| 3.4      | Electrical Characteristics                                  | <a href="#">8</a>         | 8.3                     | DEFAULT DEVICE REGISTER SETTINGS AFTER POWER ON/RESET | <a href="#">28</a>        |
| 3.5      | Serial MICROWIRE Timing Diagram                             | <a href="#">11</a>        | 8.4                     | REGISTER R0   | <a href="#">29</a>        |
| <b>4</b> | <b>Typical Performance Characteristics</b>                  | <b><a href="#">12</a></b> | 8.5                     | REGISTER R1 AND R2                                    | <a href="#">31</a>        |
| <b>5</b> | <b>Measurement Definitions</b>                              | <b><a href="#">13</a></b> | 8.6                     | REGISTER R3   | <a href="#">33</a>        |
| 5.1      | DIFFERENTIAL VOLTAGE MEASUREMENT TERMINOLOGY                | <a href="#">13</a>        | 8.7                     | REGISTER R4   | <a href="#">35</a>        |
| <b>6</b> | <b>Features</b>   | <b><a href="#">14</a></b> | 8.8                     | REGISTER R5   | <a href="#">36</a>        |
| 6.1      | SYSTEM ARCHITECTURE   | <a href="#">14</a>        | 8.9                     | REGISTER 15   | <a href="#">37</a>        |
| 6.2      | HIGH SPEED CLOCK INPUTS (CLKin0/CLKin0* and CLKin1/CLKin1*) | <a href="#">14</a>        | <b>9</b>                | <b>Application Information</b>                        | <b><a href="#">38</a></b> |
| 6.3      | CLOCK DISTRIBUTION  | <a href="#">14</a>        | 9.1                     | POWER SUPPLY  | <a href="#">38</a>        |
| 6.4      | SMALL DIVIDER (1 to 8)                                      | <a href="#">14</a>        | 9.2                     | PIN CONNECTION RECOMMENDATIONS                        | <a href="#">40</a>        |
| 6.5      | LARGE DIVIDER (1 to 1045)                                   | <a href="#">14</a>        | 9.3                     | THERMAL MANAGEMENT                                    | <a href="#">40</a>        |
| 6.6      | CLKout ANALOG DELAY   | <a href="#">14</a>        | 9.4                     | DRIVING CLKin INPUTS                                  | <a href="#">41</a>        |
| 6.7      | CLKout12 & CLKout13 DIGITAL DELAY                           | <a href="#">15</a>        | 9.5                     | TERMINATION AND USE OF CLOCK OUTPUT (DRIVERS)         | <a href="#">42</a>        |
| 6.8      | PROGRAMMABLE OUTPUTS  | <a href="#">15</a>        | <b>Revision History</b> |   | <b><a href="#">46</a></b> |

## 2 Device Information

### 2.1 Functional Configurations

**Table 2-1. Clock Output Configurations**

| Bank | Input          | Clock Group | Output CLKoutX/CLKoutX* | Output Type            | Outputs in Divider Group | Divider Ratios           | Delay                             |
|------|----------------|-------------|-------------------------|------------------------|--------------------------|--------------------------|-----------------------------------|
| A    | CLKin0/CLKin0* | CG1         | 0 to 3                  | LVDS/LVPECL            | 0 to 3                   | 1 to 8                   | No                                |
|      |                | CG2         | 4 to 7                  | LVDS/LVPECL/<br>LVCMOS | 4 to 7                   | 1 to 8                   | No                                |
| B    | CLKin1/CLKin1* | CG3         | 8 to 11                 | LVDS/LVPECL/<br>LVCMOS | 8 to 11                  | 1 to 8                   | No                                |
|      |                | CG4         | 12 and 13               | LVDS/LVPECL/<br>LVCMOS | 12 and 13                | 1 to 1045 <sup>(1)</sup> | Digital and Analog <sup>(2)</sup> |

(1) Digital Delay will not work if CLKout12\_13\_DIV = 1.

(2) See [Section 3.4](#)

**Table 2-2. Pin Control Mode for EN\_PIN\_CTRL = Low**

| Pin          | Output Groups                   | Pin=Low | Pin=Middle        | Pin=High |
|--------------|---------------------------------|---------|-------------------|----------|
| CLKoutTYPE_0 | CLKout0 to CLKout3              | LVDS    | Powerdown         | LVPECL   |
| CLKoutTYPE_1 | CLKout4 to CLKout7              | LVDS    | LVCOMS (Norm/Inv) | LVPECL   |
| CLKoutTYPE_2 | CLKout8 to CLKout13             | LVDS    | LVCMOS (Norm/Inv) | LVPECL   |
| CLKoutDIV_0  | CLKout0 to<br>CLKout3 Divider   | ÷ 1     | ÷ 4               | ÷ 2      |
| CLKoutDIV_1  | CLKout4 to<br>CLKout7 Divider   | ÷ 1     | ÷ 4               | ÷ 2      |
| CLKoutDIV_2  | CLKout8 to<br>CLKout11 Divider  | ÷ 1     | ÷ 4               | ÷ 2      |
|              | CLKout12 to<br>CLKout13 Divider | ÷ 8     | ÷ 512             | ÷ 16     |

**Table 2-3. Pin Control Mode for EN\_PIN\_CTRL = High<sup>(1)(2)</sup>**

| Pin          | Output Groups                   | Pin=Low | Pin=Middle        | Pin=High |
|--------------|---------------------------------|---------|-------------------|----------|
| CLKoutTYPE_0 | CLKout0 to CLKout3              | LVDS    | LVPECL            | LVPECL   |
|              | CLKout4 to CLKout7              |         | LVCMOS (Norm/Inv) |          |
| CLKoutTYPE_1 | CLKout8 to CLKout11             | LVDS    | LVCMOS (Norm/Inv) | LVPECL   |
| CLKoutTYPE_2 | CLKout12 to CLKout13            | LVDS    | LVCMOS (Norm/Inv) | LVPECL   |
| CLKoutDIV_0  | CLKout0 to<br>CLKout7 Dividers  | ÷ 1     | ÷ 4               | ÷ 2      |
| CLKoutDIV_1  | CLKout8 to<br>CLKout11 Divider  | ÷ 1     | ÷ 4               | ÷ 2      |
| CLKoutDIV_2  | CLKout12 to<br>CLKout13 Divider | ÷ 4     | ÷ 512             | ÷ 16     |

(1) Digital Delay will not work if CLKout12\_13\_DIV = 1.

(2) See [Section 3.4](#)

## 2.2 Connection Diagram

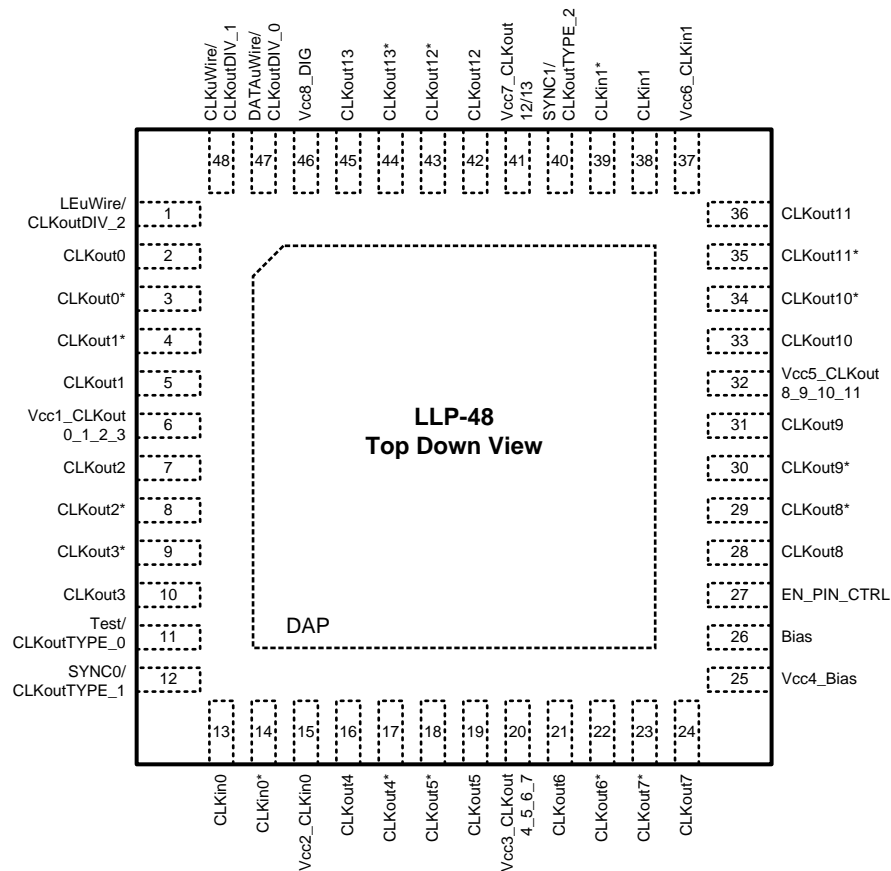


Figure 2-1. 48-Pin Package

Table 2-4. Pin Descriptions<sup>(1)</sup>

| Pin Number | Name(s)                 | I/O | Type           | Description  |
|------------|-------------------------|-----|----------------|--|
| 1          | LEuWire/<br>CLKoutDIV_2 | I   | CMOS / 3-State | MICROWIRE Latch Enable Input / Pin control mode: clock divider 2                             |
| 2, 3       | CLKout0<br>CLKout0*     | O   | Programmable   | Clock output 0: LVDS or LVPECL   |
| 4, 5       | CLKout1<br>CLKout1*     | O   | Programmable   | Clock output 1: LVDS or LVPECL   |
| 6          | Vcc1_CLKout<br>0_1_2_3  | I   | PWR            | Power supply for clock outputs 0, 1, 2, and 3  |
| 7, 8       | CLKout2,<br>CLKout2*    | O   | Programmable   | Clock output 2: LVDS or LVPECL   |
| 9, 10      | CLKout3,<br>CLKout3*    | O   | Programmable   | Clock output 3: LVDS or LVPECL   |
| 11         | Test/<br>CLKoutTYPE_0   | I   | CMOS / 3-State | Reserved Test Pin / Pin control mode: clock output type select 0                             |
| 12         | SYNC0/<br>CLKoutTYPE_1  | I   | CMOS / 3-State | SYNC0 / Pin control mode: clock output type select 1   |
| 13, 14     | CLKin0/<br>CLKin0*      | I   | ANLG           | Clock input 0. Supports clocking types including but not limited to LVDS, LVPECL, and LVCMOS |
| 15         | Vcc2_CLKin0             | I   | PWR            | Power supply for clock input 0   |

(1) See Application Information section [Section 9.2](#) for recommended connections.

Table 2-4. Pin Descriptions<sup>(1)</sup> (continued)

| Pin Number | Name(s)                   | I/O | Type           | Description  |
|------------|---------------------------|-----|----------------|--|
| 16, 17     | CLKout4/<br>CLKout4*      | O   | Programmable   | Clock output 4: LVDS, LVPECL, or LVCMOS  |
| 18, 19     | CLKout5*/<br>CLKout5      | O   | Programmable   | Clock output 5: LVDS, LVPECL, or LVCMOS  |
| 20         | Vcc3_CLKout<br>4_5_6_7    | I   | PWR            | Power supply for clock outputs 4, 5, 6, and 7  |
| 21, 22     | CLKout6/<br>CLKout6*      | O   | Programmable   | Clock output 6: LVDS, LVPECL, or LVCMOS  |
| 23, 24     | CLKout7*/<br>CLKout7      | O   | Programmable   | Clock output 7: LVDS, LVPECL, or LVCMOS  |
| 25         | Vcc4_Bias                 | I   | PWR            | Power supply for Bias  |
| 26         | Bias                      |     | ANLG           | Bias bypass pin  |
| 27         | EN_PIN_CTRL               | I   | 3-State        | Select MICROWIRE or pin control mode   |
| 28, 29     | CLKout8/<br>CLKout8*      | O   | Programmable   | Clock output 8: LVDS, LVPECL, or LVCMOS  |
| 30, 31     | CLKout9*/<br>CLKout9      | O   | Programmable   | Clock output 9: LVDS, LVPECL, or LVCMOS  |
| 32         | Vcc5_CLKout<br>8_9_10_11  | I   | PWR            | Power supply for clock outputs 8, 9, 10, and 11  |
| 33, 34     | CLKout10/<br>CLKout10*    | O   | Programmable   | Clock output 10: LVDS, LVPECL, or LVCMOS   |
| 35, 36     | CLKout11*/<br>CLKout11    | O   | Programmable   | Clock output 11: LVDS, LVPECL, or LVCMOS   |
| 37         | Vcc6_CLKin1               | I   | PWR            | Power supply for clock input 1   |
| 38, 39     | CLKin1/<br>CLKin1*        | I   | ANLG           | Clock input 1. Supports clocking types including but not limited to LVDS, LVPECL, and LVCMOS |
| 40         | SYNC1/<br>CLKoutTYPE_2    | I   | CMOS / 3-State | SYNC pin for CLKin1 and bank B.<br>Pin control mode: Clock output type select 2              |
| 41         | Vcc7_CLKout<br>12_13      | I   | PWR            | Power supply for clock outputs 12, and 13  |
| 42, 43     | CLKout12/<br>CLKout12*    | O   | Programmable   | Clock output 12: LVDS, LVPECL, or LVCMOS   |
| 44, 45     | CLKout13*/<br>CLKout13    | O   | Programmable   | Clock output 13: LVDS, LVPECL, or LVCMOS   |
| 46         | Vcc8_DIG                  | I   | PWR            | Power supply for digital   |
| 47         | DATAuWire/<br>CLKoutDIV_0 | I   | CMOS / 3-State | MICROWIRE DATA Pin / Pin control mode: Clock divider 0                                       |
| 48         | CLKuWire/<br>CLKoutDIV_1  | I   | CMOS / 3-State | MICROWIRE CLK Pin / Pin control mode: Clock divider 1  |
| DAP        | DAP                       |     | GND            | DIE ATTACH PAD, connect to GND   |



These devices have limited built-in ESD protection. The leads should be shorted together or the device placed in conductive foam during storage or handling to prevent electrostatic damage to the MOS gates.

### 3 Electrical Specifications

#### 3.1 Absolute Maximum Ratings<sup>(1)(2)(3)(4)</sup>

| Parameter                              | Symbol    | Ratings                    | Units |
|--|-----------|----------------------------|-------|
| Supply Voltage <sup>(5)</sup>          | $V_{CC}$  | -0.3 to 3.6                | V     |
| Input Voltage                          | $V_{IN}$  | -0.3 to ( $V_{CC} + 0.3$ ) | V     |
| Storage Temperature Range              | $T_{STG}$ | -65 to 150                 | °C    |
| Lead Temperature (solder 4 seconds)    | $T_L$     | +260                       | °C    |
| Differential Input Current (CLKinX/X*) | $I_{IN}$  | ± 5                        | mA    |
| Moisture Sensitivity Level             | MSL       | 3                          |       |

- (1) "Absolute Maximum Ratings" indicate limits beyond which damage to the device may occur. Operating Ratings indicate conditions for which the device is intended to be functional, but do not ensure specific performance limits. For ensured specifications and test conditions, see the Electrical Characteristics. The ensured specifications apply only to the test conditions listed.
- (2) This device is a high performance RF integrated circuit with an ESD rating up to 2.5 kV Human Body Model, up to 250 V Machine Model and up to 1,250 V Charged Device Model and is ESD sensitive. Handling and assembly of this device should only be done at ESD-free workstations.
- (3) Stresses in excess of the absolute maximum ratings can cause permanent or latent damage to the device. These are absolute stress ratings only. Functional operation of the device is only implied at these or any other conditions in excess of those given in the operation sections of the data sheet. Exposure to absolute maximum ratings for extended periods can adversely affect device reliability.
- (4) If Military/Aerospace specified devices are required, please contact the Texas Instruments Sales Office/Distributors for availability and specifications.
- (5) Never to exceed 3.6 V.

#### 3.2 Package Thermal Resistance

48-Lead WQFN

| Parameter   | Symbol        | Ratings | Units |
|---|---------------|---------|-------|
| Thermal resistance from junction to ambient on 4-layer JEDEC board <sup>(1)</sup> | $\theta_{JA}$ | 26      | °C/W  |
| Thermal resistance from junction to case <sup>(2)</sup>                           | $\theta_{JC}$ | 3       | °C/W  |

- (1) Specification assumes 9 thermal vias connect the die attach pad to the embedded copper plane on the 4-layer JEDEC board. These vias play a key role in improving the thermal performance of the WQFN. It is recommended that the maximum number of vias be used in the board layout.
- (2) Case is defined as the DAP (die attach pad).

#### 3.3 Recommended Operating Conditions

| Parameter            | Symbol   | Condition        | Min  | Typical | Max  | Unit |
|----------------------|----------|------------------|------|---------|------|------|
| Ambient Temperature  | $T_A$    | $V_{CC} = 3.3$ V | -40  | 25      | 85   | °C   |
| Supply Voltage       | $V_{CC}$ |                  | 3.15 | 3.3     | 3.45 | V    |
| Junction Temperature | $T_J$    |                  |      |         | 125  | °C   |

### 3.4 Electrical Characteristics

(3.15 V ≤ V<sub>CC</sub> ≤ 3.45 V, -40 °C ≤ T<sub>A</sub> ≤ 85 °C. Typical values represent most likely parametric norms at V<sub>CC</sub> = 3.3 V, T<sub>A</sub> = 25 °C, at the Recommended Operating Conditions at the time of product characterization and are not ensured.)

| Symbol  | Parameter   | Conditions  | Min   | Typ | Max             | Units           |
|---|---|---|-------|-----|-----------------|-----------------|
| <b>Current Consumption</b>  |   |   |       |     |                 |                 |
| I <sub>CC_PD</sub>  | Power Down Supply Current                                       |   |       | 1   |                 | mA              |
| I <sub>CC_CLKS</sub>  | Supply Current with all clocks enabled <sup>(1)</sup>           | All clock delays disabled,<br>CLKoutX_Y_DIV = 1,<br>CLKoutX_TYPE = 1 (LVDS),        |       | 313 | 390             | mA              |
| <b>CLKin0/0* and CLKin1/1* Input Clock Specifications</b>                     |   |   |       |     |                 |                 |
| f <sub>CLKinX</sub>   | Clock 0 or 1 Input Frequency                                    | CLKinX_MUX = Bypassed<br>CLKoutX_Y_DIV = 1  | 0.001 |     | 3100            | MHz             |
|   |   | CLKinX_MUX = Bypassed<br>CLKoutX_Y_DIV = 2 to 8                                     | .001  |     | 1600            | MHz             |
|   |   | CLKinX_MUX = Divide<br>CLKinX_DIV = 1 to 8  | .001  |     | 3100            | MHz             |
| SLEW <sub>CLKin</sub>   | Slew Rate on CLKin <sup>(2)</sup>                               | 20% to 80%  | 0.15  | 0.5 |                 | V/ns            |
| DUTY <sub>CLKin</sub>   | Clock input duty cycle  |   |       | 50  |                 | %               |
| V <sub>CLKin</sub>  | Clock Input,<br>Single-ended Input Voltage                      | AC coupled to CLKinX; CLKinX* AC<br>coupled to Ground<br>(CLKinX_BUF_TYPE = Bipolar | 0.25  |     | 2.4             | V <sub>pp</sub> |
|   |   | AC coupled to CLKinX; CLKinX* AC<br>coupled to Ground<br>(CLKinX_BUF_TYPE = MOS     | 0.25  |     | 2.4             | V <sub>pp</sub> |
| V <sub>IDCLKin</sub>  | Clock Input<br>Differential Input Voltage <sup>(3) (4)</sup>    | AC coupled<br>(CLKinX_BUF_TYPE = Bipolar  | 0.25  |     | 1.55            | V               |
| V <sub>SSCLKin</sub>  |   |   | 0.5   |     | 3.1             | V <sub>pp</sub> |
| V <sub>IDCLKin</sub>  |   | AC coupled<br>(CLKinX_BUF_TYPE = MOS  | 0.25  |     | 1.55            | V               |
| V <sub>SSCLKin</sub>  |   |   | 0.5   |     | 3.1             | V <sub>pp</sub> |
| V <sub>CLKinX-offset</sub>  | DC offset voltage between<br>CLKinX/CLKinX*<br>CLKinX* - CLKinX | Each pin AC coupled<br>CLKinX_BUF_TYPE = Bipolar                                    |       | 0   |                 | mV              |
|   |   |   |       | 0   |                 | mV              |
| V <sub>CLKin-VIH</sub>  | Maximum input voltage   | DC coupled to CLKinX; CLKinX* AC<br>coupled to Ground                               | 2.0   |     | V <sub>CC</sub> | V               |
| V <sub>CLKin-VIL</sub>  | Minimum input voltage   | CLKinX_BUF_TYPE = MOS   | 0.0   |     | 0.4             | V               |
| V <sub>CLKinX-offset</sub>  | DC offset voltage between<br>CLKinX/CLKinX*<br>CLKinX* - CLKinX | Each pin AC coupled<br>CLKinX_BUF_TYPE = MOS  |       | 55  |                 | mV              |
| <b>Digital Inputs (CLKuWire, DATAuWire, LEuWire) for EN_PIN_CTRL = MIDDLE</b> |   |   |       |     |                 |                 |
| V <sub>IH</sub>   | High-Level Input Voltage  |   | 1.2   |     | V <sub>CC</sub> | V               |
| V <sub>IL</sub>   | Low-Level Input Voltage   |   |       |     | 0.4             | V               |
| I <sub>IH</sub>   | High-Level Input Current  | V <sub>IH</sub> = V <sub>CC</sub>   | -5    |     | 5               | μA              |
| I <sub>IL</sub>   | Low-Level Input Current   | V <sub>IL</sub> = 0   | -5    |     | 5               | μA              |
| <b>Digital Inputs (SYNC0, SYNC1) for EN_PIN_CTRL = MIDDLE</b>                 |   |   |       |     |                 |                 |
| V <sub>IH</sub>   | High-Level Input Voltage  |   | 1.2   |     | V <sub>CC</sub> | V               |
| V <sub>IL</sub>   | Low-Level Input Voltage   |   |       |     | 0.4             | V               |
| I <sub>IH</sub>   | High-Level Input Current<br>V <sub>IH</sub> = V <sub>CC</sub>   | V <sub>IH</sub> = V <sub>CC</sub>   | -5    |     | 5               | μA              |
| I <sub>IL</sub>   | Low-Level Input Current<br>V <sub>IL</sub> = 0 V                | V <sub>IL</sub> = 0   | -40   |     | -5              | μA              |

(1) For I<sub>CC</sub> for specific part configuration, see applications section [Section 9.1.1](#) for calculating I<sub>CC</sub>.

(2) The minimum recommended slew rate for all input clocks is 0.5 V/ns. This is especially true for single-ended clocks. Phase noise performance will begin to degrade as the clock input slew rate is reduced. However, the device will function at slew rates down to the minimum listed. When compared to single-ended clocks, differential clocks (LVDS, LVPECL) will be less susceptible to degradation in phase noise performance at lower slew rates due to their common mode noise rejection. However, it is also recommended to use the highest possible slew rate for differential clocks to achieve optimal phase noise performance at the device outputs.

(3) See applications section [Section 5.1](#) for definition of V<sub>ID</sub> and V<sub>OD</sub> voltages.

(4) Refer to application note [AN-912 Common Data Transmission Parameters and their Definitions \(SNLA036\)](#) for more information.



**Electrical Characteristics (continued)**

(3.15 V ≤ V<sub>CC</sub> ≤ 3.45 V, -40 °C ≤ T<sub>A</sub> ≤ 85 °C. Typical values represent most likely parametric norms at V<sub>CC</sub> = 3.3 V, T<sub>A</sub> = 25 °C, at the Recommended Operating Conditions at the time of product characterization and are not ensured.)

| Symbol  | Parameter   | Conditions   | Min   | Typ  | Max             | Units |
|---|---|--|-------|------|-----------------|-------|
| <b>Digital Inputs (CLKuWire, DATAuWire, LEuWire, SYNC0, SYNC1) for EN_PIN_CTRL= Low or High</b> |   |  |       |      |                 |       |
| V <sub>IH</sub>   | High-Level Input Voltage  |  | 2.6   |      | V <sub>CC</sub> | V     |
| V <sub>IM</sub>   | Mid-Level Input Voltage   |  | 1.3   |      | 1.85            | V     |
| V <sub>IL</sub>   | Low-Level Input Voltage   |  |       |      | 0.7             | V     |
| I <sub>IH</sub>   | High-Level Input Current  | V <sub>IH</sub> = V <sub>CC</sub>  |       |      | 100             | μA    |
| I <sub>IM</sub>   | Mid-Level Input Current   |  | -10   |      | 10              | μA    |
| I <sub>IL</sub>   | Low-Level Input Current   | V <sub>IL</sub> = 0  | -100  |      |                 | μA    |
| <b>Clock Skew and Delay</b>   |   |  |       |      |                 |       |
| T <sub>SKEW</sub>   | CLKoutX to CLKoutY<br>(5), (6)  | LVDS-to-LVDS, T = 25 °C,<br>F <sub>CLK</sub> = 800 MHz, R <sub>L</sub> = 100 Ω<br>AC coupled, Within same Divider  |       | 3    |                 | ps    |
|   |   | LVPECL-to-LVPECL, T = 25 °C<br>F <sub>CLK</sub> = 800 MHz, R <sub>L</sub> = 100 Ω<br>emitter resistors = 240 Ω to GND<br>AC coupled, Within same Divider |       | 3    |                 |       |
|   | Skew between any two LVCMOS<br>outputs, same CLKout or different<br>CLKout (5), (6) | R <sub>L</sub> = 50 Ω, C <sub>L</sub> = 10 pF,<br>T = 25 °C, F <sub>CLK</sub> = 100 MHz, Within<br>same Divider  |       | 50   |                 |       |
| MixedT <sub>SKEW</sub><br>CLKoutX -<br>CLKoutY  | LVPECL to LVDS skew   | Same device, T = 25 °C,<br>250 MHz, Within same Divider  |       | 32   |                 | ps    |
|   | LVDS to LVCMOS skew   |  |       | 830  |                 |       |
|   | LVCMOS to LVPECL skew   |  |       | 800  |                 |       |
| F <sub>ADLY</sub>   | Maximum Analog<br>Delay Frequency   |  | 1536  |      |                 | MHz   |
| <b>LVDS Clock Outputs (CLKoutX)</b>   |   |  |       |      |                 |       |
| f <sub>CLKout</sub>   | Maximum Clock Frequency<br>(7) (8)  | R <sub>L</sub> = 100 Ω   | 1600  |      |                 | MHz   |
| V <sub>OD</sub>   | Differential Output Voltage<br>(9)<br>(10)  | T = 25 °C, DC measurement<br>AC coupled to receiver input<br>R = 100 Ω differential termination  | 225   | 400  | 575             | mV    |
| ΔV <sub>OD</sub>  | Change in Magnitude of V <sub>OD</sub> for<br>complementary output states           |  | -50   |      | 50              | mV    |
| V <sub>OS</sub>   | Output Offset Voltage   |  | 1.125 | 1.25 | 1.375           | V     |
| ΔV <sub>OS</sub>  | Change in V <sub>OS</sub> for complementary<br>output states                        |  |       |      | 35              | mV    |
| T <sub>R</sub>  | Output Rise Time  | 20% to 80%, R <sub>L</sub> = 100 Ω   |       | 200  |                 | ps    |
| T <sub>F</sub>  | Output Fall Time  | 80% to 20%, R <sub>L</sub> = 100 Ω   |       | 300  |                 | ps    |
| I <sub>SA</sub><br>I <sub>SB</sub>  | Output short circuit current - single<br>ended                                      | Single-ended output shorted to<br>GND, T = 25 °C   | -24   |      | 24              | mA    |
| I <sub>SAB</sub>  | Output short circuit current -<br>differential                                      | Complimentary outputs tied together  | -12   |      | 12              | mA    |

(5) Equal loading and identical clock output configuration on each clock output is required for specification to be valid. Specification not valid for delay mode.

(6) Ensured by characterization.

(7) Ensured by characterization.

(8) Refer to typical performance charts for output operation performance at higher frequencies than the minimum maximum output frequency.

(9) See applications section [Section 5.1](#) for definition of V<sub>ID</sub> and V<sub>OD</sub> voltages.

(10) Refer to application note [AN-912 Common Data Transmission Parameters and their Definitions \(SNLA036\)](#) for more information.

### Electrical Characteristics (continued)

(3.15 V ≤ V<sub>CC</sub> ≤ 3.45 V, -40 °C ≤ T<sub>A</sub> ≤ 85 °C. Typical values represent most likely parametric norms at V<sub>CC</sub> = 3.3 V, T<sub>A</sub> = 25 °C, at the Recommended Operating Conditions at the time of product characterization and are not ensured.)

| Symbol  | Parameter                          | Conditions   | Min                   | Typ                    | Max  | Units |
|---|------------------------------------|--|-----------------------|------------------------|------|-------|
| <b>LVPECL Clock Outputs (CLKoutX)</b>                           |                                    |  |                       |                        |      |       |
| T <sub>R</sub>  | Output Rise Time                   | 20% to 80%, R <sub>L</sub> = 100 Ω,<br>emitter resistors = 240 Ω to GND            |                       | 200                    |      | ps    |
| T <sub>F</sub>  | Output Fall Time                   | 80% to 20%, R <sub>L</sub> = 100 Ω,<br>emitter resistors = 240 Ω to GND            |                       | 200                    |      | ps    |
| <b>Low Common-Mode Voltage PECL (LCPECL)<sup>(1), (2)</sup></b> |                                    |  |                       |                        |      |       |
| f <sub>CLKout</sub>   | Maximum Clock Frequency<br>(3) (4) | R <sub>L</sub> = 100 Ω,<br>emitter resistors = 240 Ω to GND                        | 3100                  |                        |      | MHz   |
| V <sub>OH</sub>   | Output High Voltage                | T = 25 °C, DC Measurement<br>Termination = 50 Ω to<br>V <sub>CC</sub> - 0.6 V      |                       | 1.6                    |      | V     |
| V <sub>OL</sub>   | Output Low Voltage                 |  |                       | 0.75                   |      | V     |
| V <sub>OD</sub>   | Output Voltage                     |  | 535                   | 840                    | 1145 | mV    |
| <b>1600 mV LVPECL (LVPECL) Clock Outputs (CLKoutX)</b>          |                                    |  |                       |                        |      |       |
| f <sub>CLKout</sub>   | Maximum Clock Frequency<br>(3) (4) | R <sub>L</sub> = 100 Ω,<br>emitter resistors = 240 Ω to GND                        | 3100                  |                        |      | MHz   |
| V <sub>OH</sub>   | Output High Voltage                | T = 25 °C, DC Measurement<br>Termination = 50 Ω to<br>V <sub>CC</sub> - 2.0 V      |                       | V <sub>CC</sub> - 0.94 |      | V     |
| V <sub>OL</sub>   | Output Low Voltage                 |  |                       | V <sub>CC</sub> - 1.9  |      | V     |
| V <sub>OD</sub>   | Output Voltage                     |  | 585                   | 925                    | 1240 | mV    |
| <b>2000 mV LVPECL (2VPECL) Clock Outputs (CLKoutX)</b>          |                                    |  |                       |                        |      |       |
| f <sub>CLKout</sub>   | Maximum Clock Frequency<br>(3) (4) | R <sub>L</sub> = 100 Ω,<br>emitter resistors = 240 Ω to GND                        | 3100                  |                        |      | MHz   |
| V <sub>OH</sub>   | Output High Voltage                | T = 25 °C, DC Measurement<br>Termination = 50 Ω to<br>V <sub>CC</sub> - 2.3 V      |                       | V <sub>CC</sub> - 0.97 |      | V     |
| V <sub>OL</sub>   | Output Low Voltage                 |  |                       | V <sub>CC</sub> - 1.95 |      | V     |
| V <sub>OD</sub>   | Output Voltage                     |  | 705                   | 1150                   | 1585 | mV    |
| <b>LVC MOS Clock Outputs (CLKoutX)</b>                          |                                    |  |                       |                        |      |       |
| f <sub>CLKout</sub>   | Maximum Clock Frequency<br>(3) (4) | 5 pF Load  | 250                   |                        |      | MHz   |
| V <sub>OH</sub>   | Output High Voltage                | 1 mA Load  | V <sub>CC</sub> - 0.1 |                        |      | V     |
| V <sub>OL</sub>   | Output Low Voltage                 | 1 mA Load  |                       |                        | 0.1  | V     |
| I <sub>OH</sub>   | Output High Current (Source)       | V <sub>CC</sub> = 3.3 V, V <sub>O</sub> = 1.65 V                                   |                       | 28                     |      | mA    |
| I <sub>OL</sub>   | Output Low Current (Sink)          | V <sub>CC</sub> = 3.3 V, V <sub>O</sub> = 1.65 V                                   |                       | 28                     |      | mA    |
| DUTY <sub>CLK</sub>   | Output Duty Cycle<br>(3)           | V <sub>CC</sub> /2 to V <sub>CC</sub> /2, F <sub>CLK</sub> = 100 MHz, T<br>= 25 °C | 45                    | 50                     | 55   | %     |
| T <sub>R</sub>  | Output Rise Time                   | 20% to 80%, R <sub>L</sub> = 50 Ω,<br>C <sub>L</sub> = 5 pF                        |                       | 400                    |      | ps    |
| T <sub>F</sub>  | Output Fall Time                   | 80% to 20%, R <sub>L</sub> = 50 Ω,<br>C <sub>L</sub> = 5 pF                        |                       | 400                    |      | ps    |

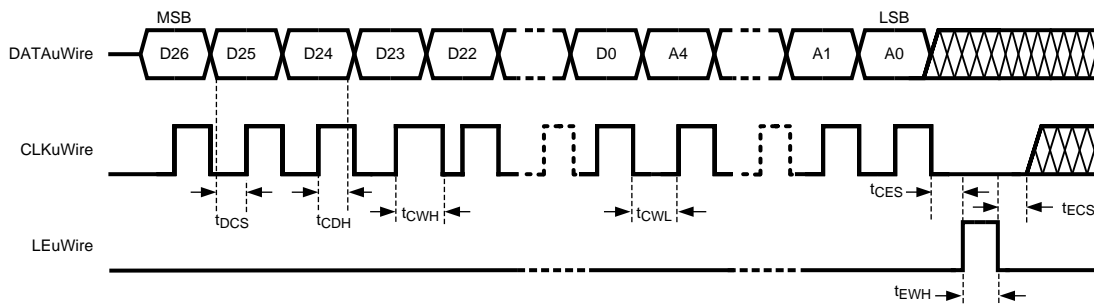
- (1) For LCPECL, the common mode voltage is regulated (V<sub>OH</sub>=1.6V, V<sub>OL</sub>=V<sub>OH</sub>-V<sub>sw</sub>, V<sub>cm</sub>=(V<sub>OH</sub>+V<sub>OL</sub>)/2 ) and is more stable against with PVT (process, supply, temperature) variations than conventional LVPECL implementations..
- (2) With proper selection of external emitter resistors, LCPECL can also be used for DC-coupling with devices with low common voltage such as 0.5V or 0.8V etc.
- (3) Ensured by characterization.
- (4) Refer to typical performance charts for output operation performance at higher frequencies than the minimum maximum output frequency.

**Electrical Characteristics (continued)**

(3.15 V ≤ V<sub>CC</sub> ≤ 3.45 V, -40 °C ≤ T<sub>A</sub> ≤ 85 °C. Typical values represent most likely parametric norms at V<sub>CC</sub> = 3.3 V, T<sub>A</sub> = 25 °C, at the Recommended Operating Conditions at the time of product characterization and are not ensured.)

| Symbol                            | Parameter                      | Conditions                    | Min | Typ | Max | Units |
|-----------------------------------|--------------------------------|-------------------------------|-----|-----|-----|-------|
| <b>MICROWIRE Interface Timing</b> |                                |                               |     |     |     |       |
| T <sub>ECS</sub>                  | LE to Clock Set Up Time        | See MICROWIRE Input Timing    | 25  |     |     | ns    |
| T <sub>DCS</sub>                  | Data to Clock Set Up Time      | See MICROWIRE Input Timing    | 25  |     |     | ns    |
| T <sub>CDH</sub>                  | Clock to Data Hold Time        | See MICROWIRE Input Timing    | 8   |     |     | ns    |
| T <sub>CWH</sub>                  | Clock Pulse Width High         | See MICROWIRE Input Timing    | 25  |     |     | ns    |
| T <sub>CWL</sub>                  | Clock Pulse Width Low          | See MICROWIRE Input Timing    | 25  |     |     | ns    |
| T <sub>CES</sub>                  | Clock to LE Set Up Time        | See MICROWIRE Input Timing    | 25  |     |     | ns    |
| T <sub>EWL</sub>                  | LE Pulse Width                 | See MICROWIRE Input Timing    | 25  |     |     | ns    |
| T <sub>CR</sub>                   | Falling Clock to Readback Time | See MICROWIRE Readback Timing | 25  |     |     | ns    |

**3.5 Serial MICROWIRE Timing Diagram**

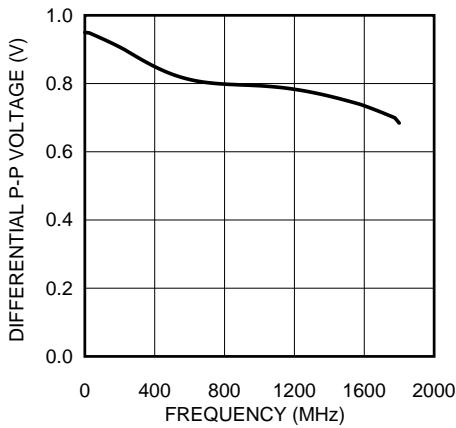


**Figure 3-1. MICROWIRE Timing Diagram**

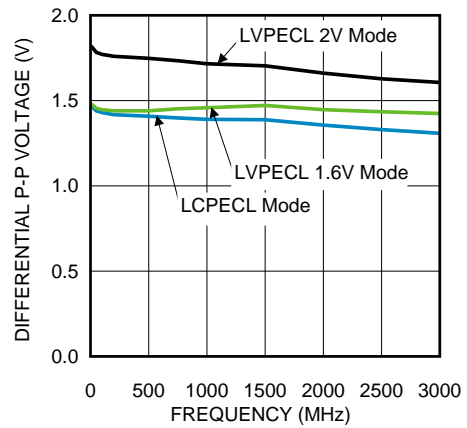
Register programming information on the DATAuWire pin is clocked into a shift register on each rising edge of the CLKuWire signal. On the rising edge of the LEuWire signal, the register is sent from the shift register to the register addressed. A slew rate of at least 30 V/μs is recommended for these signals. After programming is complete the CLKuWire, DATAuWire, and LEuWire signals should be returned to a low state.

### 4 Typical Performance Characteristics

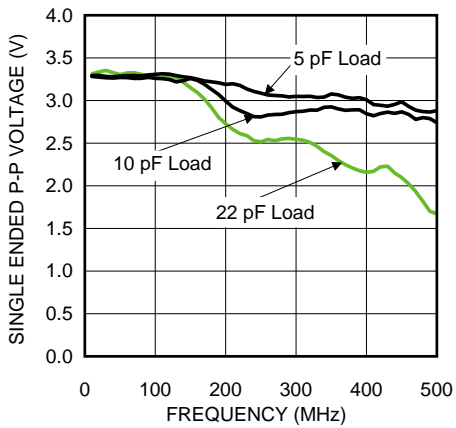
Unless otherwise specified:  $V_{dd}=3.3V$ ,  $T_A=25\text{ }^\circ\text{C}$



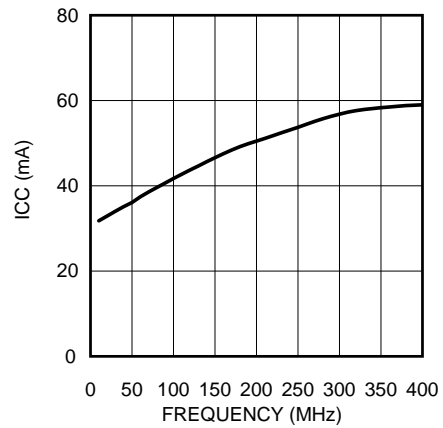
See Section 5.1 for a description of  $V_{SS}$ .  
**Figure 4-1. LVDS  $V_{SS}$  vs. Frequency**



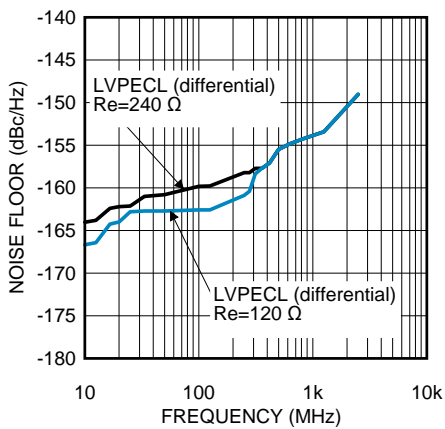
See Section 5.1 for a description of  $V_{SS}$ .  
**Figure 4-2. LVPECL  $V_{SS}$  vs. Frequency**



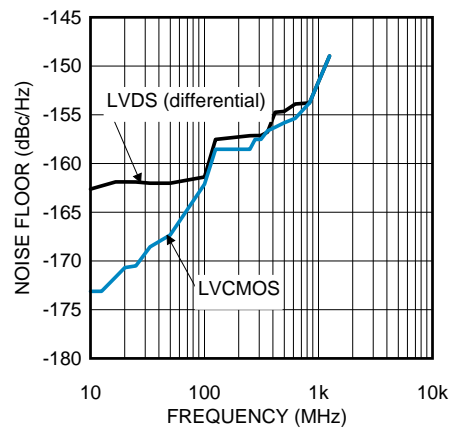
**Figure 4-3. LVCMOS  $V_{pp}$  vs. Frequency**



**Figure 4-4. Typical Dynamic  $I_{CC}$ ,  $C_L = 5\text{ pF}$**



**Figure 4-5. LVPECL Noise Floor vs. Frequency**



See Section 5.1 for a description of  $V_{SS}$ .  
**Figure 4-6. LVDS & LVCMOS Noise Floor vs. Frequency**

## 5 Measurement Definitions

### 5.1 DIFFERENTIAL VOLTAGE MEASUREMENT TERMINOLOGY

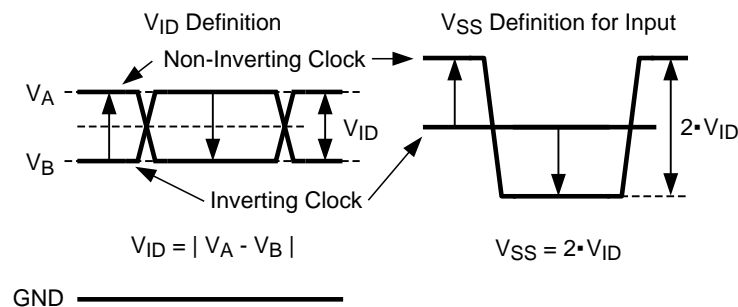
The differential voltage of a differential signal can be described by two different definitions causing confusion when reading datasheets or communicating with other engineers. This section will address the measurement and description of a differential signal so that the reader will be able to understand and discern between the two different definitions when used.

The first definition used to describe a differential signal is the absolute value of the voltage potential between the inverting and non-inverting signal. The symbol for this first measurement is typically  $V_{ID}$  or  $V_{OD}$  depending on if an input or output voltage is being described.

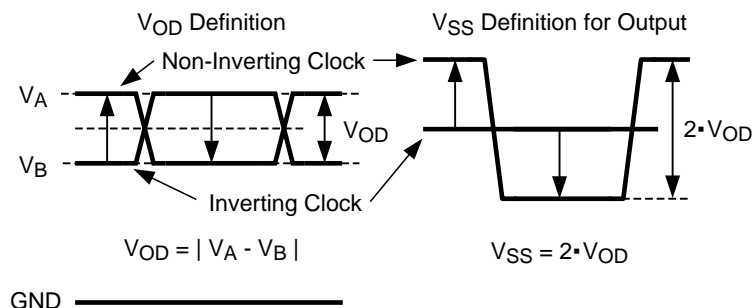
The second definition used to describe a differential signal is to measure the potential of the non-inverting signal with respect to the inverting signal. The symbol for this second measurement is  $V_{SS}$  and is a calculated parameter. Nowhere in the IC does this signal exist with respect to ground, it only exists in reference to its differential pair.  $V_{SS}$  can be measured directly by oscilloscopes with floating references, otherwise this value can be calculated as twice the value of  $V_{OD}$  as described in the first section

Figure 5-1 illustrates the two different definitions side-by-side for inputs and Figure 5-2 illustrates the two different definitions side-by-side for outputs. The  $V_{ID}$  and  $V_{OD}$  definitions show  $V_A$  and  $V_B$  DC levels that the non-inverting and inverting signals toggle between with respect to ground.  $V_{SS}$  input and output definitions show that if the inverting signal is considered the voltage potential reference, the non-inverting signal voltage potential is now increasing and decreasing above and below the non-inverting reference. Thus the peak-to-peak voltage of the differential signal can be measured.

$V_{ID}$  and  $V_{OD}$  are often defined in volts (V) and  $V_{SS}$  is often defined as volts peak-to-peak ( $V_{PP}$ ).



**Figure 5-1. Two Different Definitions for Differential Input Signals**



**Figure 5-2. Two Different Definitions for Differential Output Signals**

## 6 Features

### 6.1 SYSTEM ARCHITECTURE

The LMK01801 is a dual clock buffer which allows separate clock domains on the same IC with options to divide and delay signals.

The LMK01801 consists of two separate buffer banks, each with its own input divider, output dividers and programmable control of clock output channels.

- Bank A has two clock output groups, see the [Section 2.1](#) for more details.
- Bank B has two clock output groups, one of which has analog and digital delay. See the [Section 2.1](#) for more details.

Each bank has its own common input divider and is then divided into output groups which share an output divider.

The LMK01801 comes in a 48-pin WQFN package.

### 6.2 HIGH SPEED CLOCK INPUTS (CLKin0/CLKin0\* and CLKin1/CLKin1\*)

The LMK01801 has two clock inputs, CLKin0 and CLKin1 which can be driven differentially or single-ended. See [Section 9.4](#) for more information. Each input has a 2 to 8 divider that may be enabled or bypassed.

### 6.3 CLOCK DISTRIBUTION

The LMK01801 features a total of 14 differential outputs. CLKout0 through CLKout7 are driven from CLKin0 and CLKout8 through CLKout13 are driven from CLKin1.

### 6.4 SMALL DIVIDER (1 to 8)

There are three small dividers which drive CLKout0 to CLKout3, CLKout4 to CLKout7, and CLKout8 to CLKout11. These dividers support a divide range of 1 to 8 (even and odd).

### 6.5 LARGE DIVIDER (1 to 1045)

The divider for CLKout12 and CLKout13 supports a divide range of 1 to 1045 (even and odd). When divides of 26 or greater are used, the divider/delay block uses extended mode.

### 6.6 CLKout ANALOG DELAY

Clock outputs 12 and 13 include a fine (analog) delay for phase adjustment of the clock outputs.

The fine (analog) delay allows a nominal 25 ps step size and range from 0 to 475 ps of total delay. Enabling the analog delay adds a nominal 500 ps of delay in addition to the programmed value.

When adjusting analog delay, glitches may occur on the clock outputs being adjusted.

## 6.7 CLKout12 & CLKout13 DIGITAL DELAY

CLKout12 and CLKout13 includes a coarse (digital) delay for phase adjustment of the clock outputs.

The coarse (digital) delay allows a group of outputs to be delayed by 4.5 to 12 clock distribution path cycles in normal mode, or from 12.5 to 522 clock cycles in extended mode. The delay step can be as small as half the period of the clock distribution path by using the CLKout12\_13\_HS bit. e.g. 2 GHz clock frequency without using CLKin1 input clock divider results in 250 ps coarse tuning steps.

The coarse (digital) delay value takes effect on the clock outputs after a SYNC event.

There are 2 different ways to use the digital (coarse) delay.

1. Fixed Digital Delay
2. Relative Dynamic Digital Delay

These are further discussed in the Functional Description.

## 6.8 PROGRAMMABLE OUTPUTS

The outputs of the LMK01801 are programmable in a combination of output types based on [Table 2-1](#). Programming the outputs is by MICROWIRE or by pin control mode based on the state of EN\_PIN\_CTRL pin.

Any LVPECL output type can be programmed to LCPECL, 1600, or 2000 mVpp amplitude levels. The 2000 mVpp LVPECL output type is a Texas Instruments proprietary configuration that produces a 2000 mVpp differential swing for compatibility with many data converters and is also known as 2VPECL.

## 6.9 CLOCK OUTPUT SYNCHRONIZATION

Using the SYNC input causes all active clock outputs to share a rising edge. See [Section 7.6](#) for more information.

The SYNC event also causes the digital delay value to take effect.

## 6.10 DEFAULT CLOCK OUTPUTS

The power on reset sets the device to operate with all outputs active in bypass mode (no divide) with LVDS output type. In this way the device can be used without programming for fan-out purposes.

## 7 Functional Description

### 7.1 PROGRAMMABLE MODE

When the EN\_PIN\_CTRL pin is floating (default by internal pull-up/pull-down) then programming is via MICROWIRE.

See [Table 2-1](#) for a description of available programming options for the LMK01801 in programmable mode.

### 7.2 PIN CONTROL MODE

The LMK01801 provides for an alternate function of the MICROWIRE (uWire) pins. This pin control mode is set by the logic of the EN\_PIN\_CTRL pin to provide limited control of the outputs and dividers.

When the EN\_PIN\_CTRL pin is set high or low (not open) then the output states can be programmed by pins, eliminating the need for an external FPGA or CPU.

If EN\_PIN\_CTRL is LOW then [Table 2-2](#) in [Section 2.1](#) defines how the outputs and dividers are configured.

If EN\_PIN\_CTRL is HIGH then [Table 2-3](#) in [Section 2.1](#) defines how the outputs and dividers are configured.

### 7.3 INPUTS / OUTPUTS

#### 7.3.1 CLKin0 and CLKin1

There are two clock inputs CLKin0 and CLKin1. CLKin0 provides the input for output Bank A and CLKin1 provides the input for the output Bank B. Each input has its own divider (2 to 8) that may be bypassed.

### 7.4 INPUT AND OUTPUT DIVIDERS

This section discusses the recommended usage of input and output dividers.

Clock inputs 0 and 1 each have an associated divider (2 to 8) that may be enabled or bypassed.

Clock groups 1, 2 and 3 have small output dividers (1 to 8). Clock group 4 (CLKout12 and CLKout13) has a large output divider (1 to 1045).

While the input and output clock dividers may be used in any combination the recommended operating frequency ranges are shown in the table below to minimize the phase noise floor:

**Table 7-1. Input and Output Divider Input Frequency Ranges**

| Input Divider   | Output Divider  | Max Frequency |
|-----------------|-----------------|---------------|
| Bypassed        | Divide = 1      | 3.1 GHz       |
| Bypassed        | Divide > 1      | 1.6 GHz       |
| Divide = 2 to 8 | Divide = 1 to 8 | 3.1 GHz       |

### 7.5 FIXED DIGITAL DELAY

This section discusses Fixed Digital Delay and associated registers.

Clock outputs 12 and 13 may be delayed relative to CLKout8 to CLKout 11 by up to 517.5 clock distribution path periods if divide is 1 and 518.5 clock distribution path periods if divide is greater than 1. By programming a digital delay value from 4.5 to 522 clock distribution path periods, a relative clock output delay from 0 to 517.5 periods is achieved. The CLKout12\_13\_DDLY register sets the digital delay as shown in the table [Table 7-2](#).



**Table 7-2. Possible Digital Delay Values**

| CLKout12_13_DDLY | CLKout12_13_HS | Digital Delay |
|------------------|----------------|---------------|
| 5                | 1              | 4.5           |
| 5                | 0              | 5             |
| 6                | 1              | 5.5           |
| 6                | 0              | 6             |
| 7                | 1              | 6.5           |
| 7                | 0              | 7             |
| ...              | ...            | ...           |
| 520              | 0              | 520           |
| 521              | 1              | 520.5         |
| 521              | 0              | 521           |
| 522              | 1              | 521.5         |
| 522              | 0              | 522           |

The CLKout12\_13\_DDLY value only takes effect during a SYNC event and if the NO\_SYNC\_CLKout12\_13 bit is cleared for this clock group. See [Section 7.6](#) for more information.

The resolution of digital delay is related to the frequency at the input to the Clock Group 4 (CG4) clock distribution path.

$$\text{Digital Delay Resolution} = 1 / (2 * \text{Clock Frequency})$$

The digital delay between clock outputs can be dynamically adjusted with minimum or no disruption of the output clocks. See [Section 7.6.1](#) for more information.

### 7.5.1 Fixed Digital Delay - Example

Given a CLKin1 clock frequency of 983.04 MHz as input to CG4, by using digital delay the outputs can be adjusted in  $1 / (2 * 983.04 \text{ MHz}) = \sim 509 \text{ ps}$  steps (Assumes CLKin1\_MUX = bypass).

To achieve a quadrature (90 degree) phase shift on 122.88 MHz outputs between CLKout12 and CLKout11 from a clock frequency of 983.04 MHz program:

- Clock output divider to 8. CLKout8\_11 = 8 and CLKout12\_13\_DIV = 8
- Set clock digital delay value. CLKout12\_13\_DDLY = 5, CLKout12\_13\_HS = 0.

The frequency of 122.88 MHz has a period of  $\sim 8.14 \text{ ns}$ . To delay 90 degrees of a 122.88 MHz clock period requires a  $\sim 2.03 \text{ ns}$  delay. Given a digital delay step of  $\sim 509 \text{ ps}$ , this requires a digital delay value of 4 steps ( $2.03 \text{ ns} / 509 \text{ ps} = 4$ ). Since the 4 steps are half period steps, CLKout12\_13\_DDLY is programmed 2 full periods beyond 5 for a total of 7.

[Table 7-3](#) shows some of the possible phase delays in degrees achievable in the above example.

**Table 7-3. Relative phase shift from CLKout12 and CLKout13 to CLKout8 to CLKout11**

| CLKout12_13_DDLY | CLKout12_13_HS | Relative Digital Delay | Degrees of 122.88 MHz |
|------------------|----------------|------------------------|-----------------------|
| 5                | 1              | -0.5                   | -23°                  |
| 5                | 0              | 0.0                    | 0°                    |
| 6                | 1              | 0.5                    | 23°                   |
| 6                | 0              | 1.0                    | 45°                   |
| 7                | 1              | 1.5                    | 68°                   |
| 7                | 0              | 2.0                    | 90°                   |
| 8                | 1              | 2.5                    | 113°                  |
| 8                | 0              | 3.0                    | 135°                  |
| 9                | 1              | 3.5                    | 158°                  |

**Table 7-3. Relative phase shift from  
CLKout12 and CLKout13 to CLKout8 to CLKout11  
(continued)**

| CLKout12_13_DDLY | CLKout12_13_HS | Relative Digital Delay | Degrees of 122.88 MHz |
|------------------|----------------|------------------------|-----------------------|
| 9                | 0              | 4.0                    | 180°                  |
| 10               | 1              | 4.5                    | 203°                  |
| 10               | 0              | 5.0                    | 225°                  |
| 11               | 1              | 5.5                    | 248°                  |
| 11               | 0              | 6.0                    | 270°                  |
| 12               | 1              | 6.5                    | 293°                  |
| 12               | 0              | 7.0                    | 315°                  |
| 13               | 1              | 7.5                    | 338°                  |
| 13               | 0              | 8.0                    | 360°                  |
| ...              | ...            | ...                    | ...                   |

Figure 7-2 illustrates clock outputs programmed with different digital delay values during a SYNC event.

Refer to [Section 7.6.1](#) for more information on dynamically adjusting digital delay.

## 7.6 CLOCK OUTPUT SYNCHRONIZATION (SYNC)

The purpose of the SYNC function is to synchronize the clock outputs with a fixed and known phase relationship between each clock output selected for SYNC. SYNC can also be used to hold the outputs in a low or 0 state. The NO\_SYNC\_CLKoutX\_Y bits can be set to disable synchronization for a clock group.

The digital delay value set by CLKout12\_13\_DDLY takes effect only upon a SYNC event. The digital delay due to CLKout12\_13\_HS takes effect immediately upon programming. See [Section 7.6.1](#) for more information on dynamically changing digital delay.

It is necessary to ensure that the CLKin1 signal is stable before a sync event occurs when CLKout12\_13\_DIV is greater than 1.

### Effect of SYNC

When SYNC is asserted, the outputs to be synchronized are held in a logic low state. When SYNC is unasserted, the clock outputs to be synchronized are activated and will transition to a high state simultaneously with one another except where digital delay values have been programmed.

Refer to [Section 7.6.1](#) for SYNC functionality when SYNC\_QUAL = 1.

**Table 7-4. Steady State Clock Output Condition Given Specified Inputs**

| SYNC_POL_INV | SYNC Pin | Clock Steady State |
|--------------|----------|--------------------|
| 0            | 0        | Active             |
| 0            | 1        | Low                |
| 1            | 0        | Low                |
| 1            | 1        | Active             |

### Methods of Generating SYNC

There are three methods to generate a SYNC event:

- Manual:
  - Asserting the SYNC pin according to the polarity set by SYNC\_POL\_INV.
  - Toggling the SYNC\_POL\_INV bit though MICROWIRE will cause a SYNC to be asserted.
- Automatic:
  - Programming Register R4 when SYNC\_EN\_AUTO = 1 will generate a SYNC event for Bank B.
  - Programming Register R5 when SYNC\_EN\_AUTO = 1 will generate a SYNC event for both Bank A and Bank B.

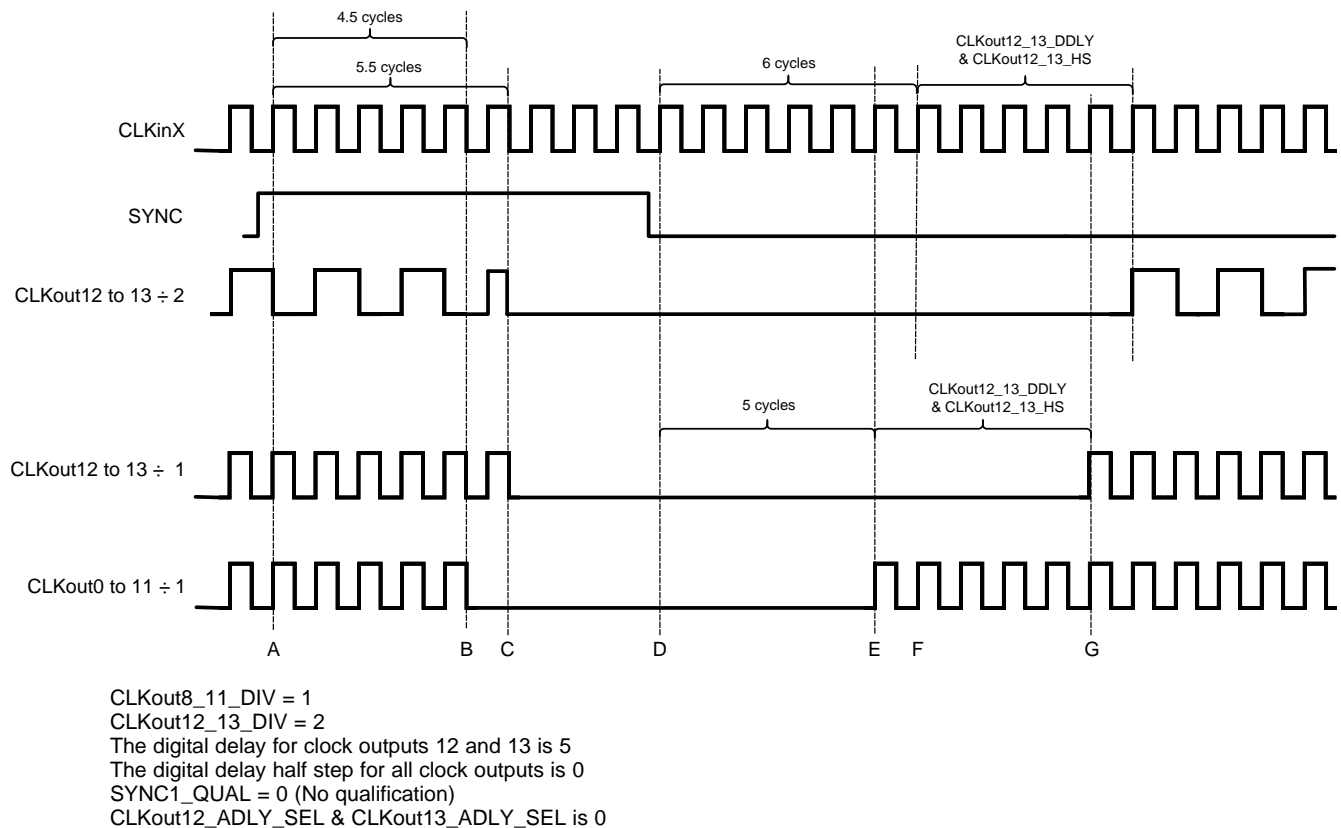
Due to the high speed of the clock distribution path (as fast as ~322 ps period) and the slow slew rate of the SYNC, the exact clock cycle at which the SYNC is asserted or unasserted by the SYNC is undefined. The timing diagrams show a sharp transition of the SYNC to clarify functionality.

### Avoiding clock output interruption due to SYNC

If a clock output has the NO\_SYNC\_CLKoutX\_Y bits set they will be unaffected by the SYNC event. It is possible to perform a SYNC operation with the NO\_SYNC\_CLKoutX\_Y bit cleared, set the NO\_SYNC\_CLKoutX\_Y bits so that the selected clocks will not be affected by a future SYNC. Future SYNC events will not effect these clocks but will still cause the newly synchronized clocks to be resynchronized using the currently programmed digital delay values. When this happens, the phase relationship between the first group of synchronized clocks and the second group of synchronized clocks will be undefined. Except for CLKout12 and CLKout13 when synced using qualification mode. See [Section 7.6.1](#).

### SYNC Timing

When discussing the timing of the SYNC function, one cycle refers to one period of the clock distribution path.

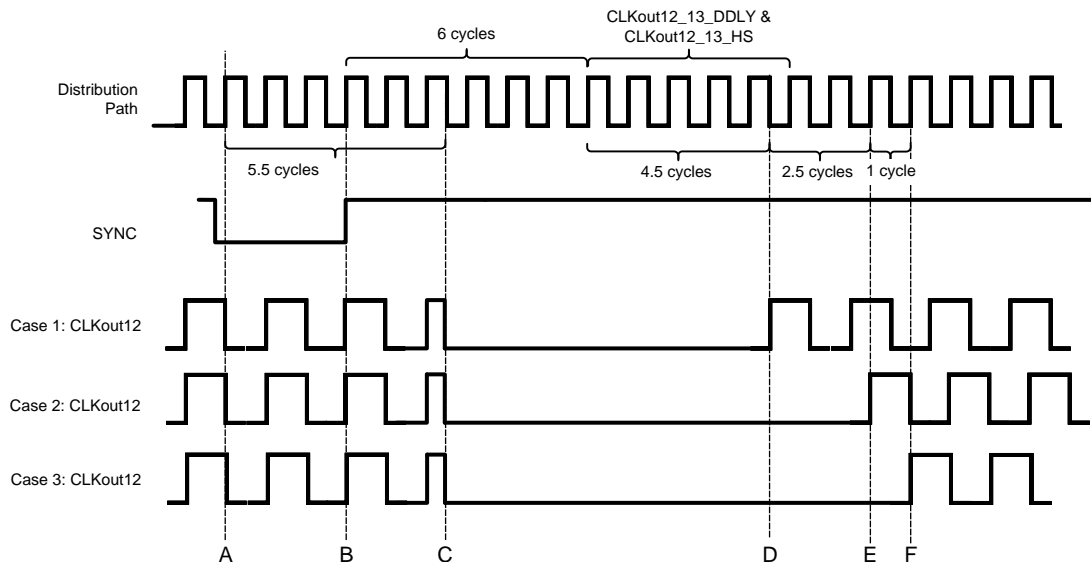


**Figure 7-1. Clock Output synchronization using the SYNC1 pin (SYNC1 is Active Low, SYNC1\_POL\_INV=0)**

Refer to [Figure 7-1](#) during this discussion on the timing of SYNC. SYNC must be asserted for greater than one clock cycle of the clock distribution path to register the SYNC event. After SYNC is asserted the SYNC event will begin on the following rising edge of the distribution path clock, at time A. After this event has been registered, the outputs will not reflect the low state for 4.5 cycles for CLKout0 - CLKout11 at time B or 5.5 cycles for CLKout12 and CLKout 13 if divide = 1 or 6.5 cycles for CLKout12 and CLKout13 if divide > 1, at time C. Due to the asynchronous nature of SYNC with respect to the output clocks, it is possible that a runt pulse could be created when the clock output goes low from the SYNC event. This is shown by CLKout12-13. See [Section 7.6.1.2](#) for more information on synchronizing relative to an output clock to eliminate or minimize this runt pulse for CLKout12 or CLKout13.

After SYNC becomes unasserted the event will be registered on the following rising edge of the distribution path clock, time D. Clock outputs 0 through 11 will rise at time E, coincident with a rising distribution clock edge that occurs after 5 cycles for CLKout0 to CLKout 11 and for CLKout12 to CLKout13 if CLKout12\_13\_DIV = 1. If CLKout12\_13\_DIV > 1 then the rising edge of CLKout12-CLKout13 will occur after 6 cycles of the distribution path at time F plus as many more cycles as programmed by the digital delay for that clock output path. The CLKout12 and CLKout13 will rise at time G, which is the Digital Delay value plus 5 cycles when CLKout12\_13\_DIV = 1 or 6 cycles when CLKout12\_13\_DIV > 1.

See [Figure 7-2](#) for further SYNC timing detail using different digital delays.



Case 1: CLKout12\_13\_DIV = 2, CLKout12\_13\_DDLY = 5  
 Case 2: CLKout12\_13\_DIV = 2, CLKout12\_13\_DDLY = 7  
 Case 3: CLKout12\_13\_DIV = 2, CLKout12\_13\_DDLY = 8  
 Case 1: CLKout12\_13\_HS = 1  
 Case 2: CLKout12\_13\_HS = 0  
 Case 3: CLKout12\_13\_HS = 0  
 SYNC1\_QUAL = 0 (No qualification)  
 CLKout12\_ADLY\_SEL & CLKout13\_ADLY\_SEL is 0

**Figure 7-2. Clock Output synchronization using the SYNC pin (SYNC is Active Low, SYNC\_POL\_INV=1)**

Figure 7-2 illustrates the timing with various digital delays programmed.

- Time A) SYNC assertion event is registered.
- Time B) SYNC unassertion registered.
- Time C) All outputs toggle and remain low. A runt pulse can occur at this time as shown.
- Time D) After  $6 + 4.5 = 10.5$  cycles, in Case 1, CLKout12 rises.
- Time E) After  $6 + 7 = 13$  cycles, in Case 2, CLKout12 rises.
- Time F) After  $6 + 8 = 14$  cycles, Case 3, CLKout12 rises.
- Note: CLKout 12 and CLKout 13 are driven by the same divider and delay circuit, therefore, their timing is always the same except when analog delay is used.

### 7.6.1 Dynamically Programming Digital Delay

To use dynamic digital delay **synchronization qualification** set SYNC1\_QUAL = 3. This causes the SYNC pulse to be qualified by a clock output so that the SYNC event occurs after a specified time from a clock output transition. This allows the relative adjustment of clock output phase in real-time with no or minimum interruption of clock outputs. Hence the term dynamic digital delay.

Note that changing the phase of a clock output requires momentarily altering in the rate of change of the clock output phase and therefore by definition results in a frequency distortion of the signal.

Without qualifying the SYNC with an output clock, the newly synchronized clocks would have a random and unknown digital delay (or phase) with respect to clock outputs not currently being synchronized. Only CLKout12 can be used as a qualifying clock.

### Relative Dynamic Digital Delay

When the qualifying clock digital delay is being adjusted, because the qualifying clock and the adjusted clock are the same, then a **relative dynamic digital delay** adjust is performed. Clocks with NO\_SYNC\_CLKoutX\_Y = 1 are defined as clocks not being adjusted. These clocks operate without interruption.

### SYNC and Minimum Step Size

The minimum step size adjustment for digital delay is half a clock distribution path cycle. This is achieved by using the CLKout12\_13\_HS bit. The CLKout12\_13\_HS bit change effect is immediate without the need for SYNC. To shift digital delay using CLKout12\_13\_DDLY, a SYNC signal must be generated for the change to take effect.

### Programming Overview

To dynamically adjust the digital delay with respect to an existing clock output the device should be programmed as follows:

- Set SYNC1\_QUAL = 3 for clock output qualification.
- Set NO\_SYNC\_CLKout12\_13 = 0 to enable synchronization on CLKout12 and CLKout13.
- Set CLKout12\_ADLY\_SEL = 0.
- Set NO\_SYNC\_CLKoutX\_Y = 1 for the output clocks, except CLKout12 and CLKout13, that will continue to operate during the SYNC event. There is no interruption of output on these clocks.
- The SYNC\_EN\_AUTO bit may be set to cause a SYNC event to begin when register R4 is programmed. The auto SYNC feature is a convenience since it does not require the application to manually assert SYNC by toggling the SYNC\_POL\_INV bit or the SYNC pin when changing digital delay.

### Internal Dynamic Digital Delay Timing

Once SYNC is qualified by an output clock, 1.5 cycles later an internal one shot pulse will occur. The width of the one shot pulse is 3 cycles. This internal one shot pulse will cause the outputs to turn off and then back on with a fixed delay with respect to the falling edge of the qualification clock. This allows for dynamic adjustments of digital delay with respect to an output clock.

The qualified SYNC timing is shown in [Figure 7-3](#) for relative dynamic digital delay.

### Dynamic Digital Delay Conditions

To perform a dynamic digital delay adjustment, the analog delay must be bypassed by setting CLKout12\_ADLY\_SEL to 0. If the analog delay is not bypassed the output synchronization may be inaccurate due to unknown analog delay settings.

When adjusting digital delay dynamically, the falling edge of the qualifying clock must coincide with the falling edge of the clock distribution path. For this requirement to be met, program the CLKout12\_13\_HS value of the qualifying clock group according to [Table 7-5](#).

**Table 7-5. Half Step programming requirement of qualifying clock during SYNC event**

| CLKout12_13_DIV value | CLKout12_13_HS              |
|-----------------------|-----------------------------|
| Odd                   | Must = 1 during SYNC event. |
| Even                  | Must = 0 during SYNC event. |

### 7.6.1.1 RELATIVE DYNAMIC DIGITAL DELAY

Relative dynamic digital delay can be used to program a clock output to a specific phase offset from another clock output.

Pros:

- Direct phase adjustment with respect to same clock output.
- Possible glitch pulses from clock output will always be the same during digital delay adjustment transient.

Cons:

- For some clock divide values there may be a glitch pulse due to SYNC assertion.
- Adjustments of digital delay requiring the half step bit (CLKout12\_13\_HS) for finer digital delay adjust is complicated due to the half step requirement in [Table 7-5](#) above.

### 7.6.1.2 RELATIVE DYNAMIC DIGITAL DELAY - EXAMPLE

To illustrate the relative dynamic digital delay adjust procedure, consider the following example.

#### System Requirements:

- CLKin1 Frequency = 983.04 MHz
- CLKout8 = 983.04 MHz (CLKout8\_11\_DIV = 1)
- CLKout12 = 491.52 MHz (CLKout12\_13\_DIV = 2)
- During initial programming:
  - CLKout12\_13\_DDLY = 5
  - CLKout12\_13\_HS = 0
  - NO\_SYNC\_CLKoutX\_Y = 0

The application requires the 491.52 MHz clock to be stepped in 90 degree steps (~508.6 ps), which is the minimum step resolution allowable by the clock distribution path. That is  $1 / 983.04 \text{ MHz} / 2 = \sim 169.5 \text{ ps}$ . During the stepping of the 491.52 MHz clocks the 983.04 MHz clock must not be interrupted.

**Step 1:** The device is programmed from register R0 to R5 with values that result in the device operating as desired, see the system requirements above. The phase of all the output clocks are aligned because all the digital delay and half step values were the same when the SYNC was generated by programming register R5. The timing of this is as shown in [Figure 7-1](#).

**Step 2:** Now the registers will be programmed to prepare for changing digital delay (or phase) dynamically.

| Register                 | Purpose   |
|--------------------------|---|
| SYNC1_QUAL = 3           | Use clock output for qualifying the SYNC pulse for dynamically adjusting digital delay.   |
| NO_SYNC_CLKout7_11 = 1   | Clock output 8 (983.04 MHz) won't be affected by SYNC. It will operate without interruption.  |
| SYNC1_AUTO = 0 (default) | Automatically generation of SYNC is not allowed because of the half step requirement. SYNC must be generated manually by toggling the SYNC_POL_INV bit or the SYNC pin. |

After the above registers have been programmed, the application may now dynamically adjust the digital delay of the 491.52 MHz clocks.

**Step 3:** Adjust digital delay of CLKout12 by one step.

Refer to [Table 7-6](#) for the programming sequence to step one half clock distribution period forward or backwards.

**Table 7-6. Programming sequence for one step adjust**

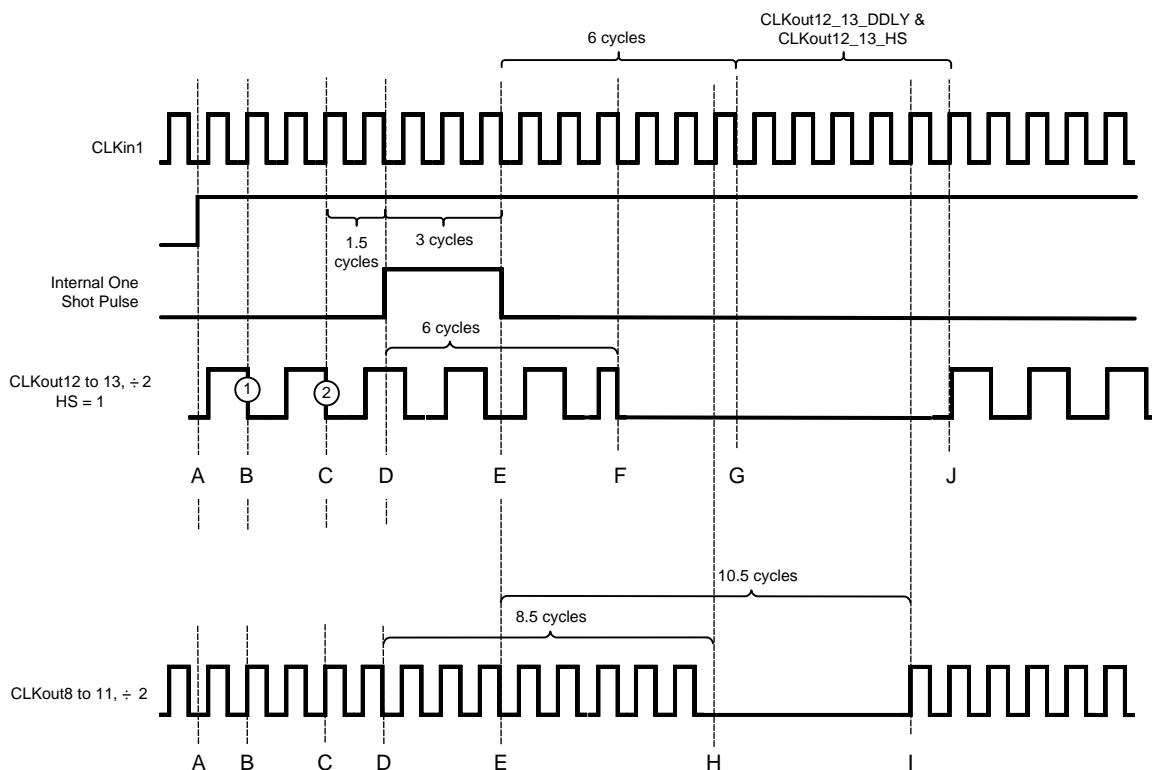
| Step direction and current HS state                           | Programming Sequence   |
|---|--|
| Adjust clock output one step forward.<br>CLKout12_13_HS = 0.  | 1. CLKout12_13_HS = 1.   |
| Adjust clock output one step forward.<br>CLKout12_13_HS = 1.  | 1. CLKout12_13_DDLY = 9.<br>2. Perform SYNC event.<br>3. CLKout12_13_HS = 0. |
| Adjust clock output one step backward.<br>CLKout12_13_HS = 0. | 1. CLKout12_13_HS = 1.<br>2. CLKout12_13_DDLY = 5.<br>3. Perform SYNC event. |
| Adjust clock output one step backward.<br>CLKout12_13_HS = 1. | 1. CLKout12_13_HS = 0.   |

To fulfill the qualifying clock output half step requirement in [Table 7-5](#) when dynamically adjusting digital delay, the CLKout12\_13\_HS bit must be set if CLKout12 or CLKout13 has an odd divide. So before any dynamic digital delay adjustment, CLKout12\_13\_HS must be set because the clock divide value is odd. To achieve the final required digital delay adjustment, the CLKout12\_13\_HS bit may be cleared after SYNC.

If a SYNC is to be generated this can be done by toggling the SYNC pin or by toggling the SYNC\_POL\_INV bit. Because of the internal one shot pulse, no strict timing of the SYNC pin or SYNC\_POL\_INV bit is required. After the SYNC event, the clock output will be at the specified phase. See [Figure 7-3](#) for a detailed view of the timing diagram. The timing diagram critical points are:

- Time A) SYNC assertion event is registered.
- Time B) First qualifying falling clock output edge.
- Time C) Second qualifying falling clock output edge.
- Time D) Internal one shot pulse begins. 5.5 cycles later CLKout12 outputs will be forced low while 8.5 cycles later CLKout8 outputs will be forced low.
- Time E) Internal one shot pulse ends. 6 cycles + digital delay cycles later CLKout12 or CLKout13 outputs rise. 10 cycles later CLKout8 to CLKout11 outputs rise.
- Time F) CLKout12 to CLKout13 outputs are forced low.
- Time G) Beginning of digital delay cycles.
- Time H) CLKout8 to CLKout11 outputs are forced low.
- Time I) CLKout8 to CLKout11 outputs rise now.
- Time j) For CLKout12\_13\_DDLY = 5; the CLKout12 and CLKout13 outputs rise now.





(SYNC1\_QUAL = 1, Qualify with clock output)  
 Starting condition is after half step is removed (CLKout12\_13\_HS = 0).

**Figure 7-3. Relative Dynamic Digital Delay Programming Example, 2nd adjust**

## 8 General Programming Information

LMK01801 devices are programmed using 32-bit registers. Each register consists of a 4-bit address field and 23-bit data field. The address field is formed by bits 0 through 3 (LSBs) and the data field is formed by bits 4 through 31 (MSBs). The contents of each register is clocked in MSB first (bit 31), and the LSB (bit 0) last. During programming, the LE signal should be held LOW. The serial data is clocked in on the rising edge of the CLK signal. After the LSB (bit 0) is clocked in the LE signal should be toggled LOW-to-HIGH-to-LOW to latch the contents into the register selected in the address field. It is recommended to program registers in numeric order, for example R0 to R5 and R15 to achieve proper device operation. [Figure 3-1](#) illustrates the serial data timing sequence.

### 8.1 RECOMMENDED PROGRAMMING SEQUENCE

Registers are programmed in numeric order with R0 being the first and R15 being the last register programmed. The recommended programming sequence involves programming R0 with the reset bit (b4) set to 1 to ensure the device is in a default state. Then R0 is programmed again, the reset bit is cleared to 0 during the re-programming of R0.

#### 8.1.1 Overview

- R0 (Init):
  - Program R0 with RESET = 1. This ensures that the device is configured with default settings. When RESET =1, all other R0 bits are ignored.
- R0: Powerdown Controls and CLKin Dividers
  - Program R0 with RESET = 0
- R1 and R2: Clock output types
- R3: SYNC Features and Analog Delay for CLKout12 and CLKout13
- R4: Dynamic Digital Delay for CLKout12 and CLKout13
- R5: CLKout Dividers and Analog Delay Select
- R15: uWireLock

## 8.2 REGISTER MAP

Table 8-1 provides the register map for device programming:

**Table 8-1. Register Map**

| Register | 31           | 30 | 29 | 28           | 27              | 26         | 25           | 24            | 23         | 22           | 21            | 20         | 19                  | 18                 | 17                | 16                | 15               | 14            | 13                | 12                | 11             | 10               | 9             | 8 | 7 | 6 | 5             | 4 | 3         | 2 | 1 | 0 |   |  |  |  |  |
|----------|--------------|----|----|--------------|-----------------|------------|--------------|---------------|------------|--------------|---------------|------------|---------------------|--------------------|-------------------|-------------------|------------------|---------------|-------------------|-------------------|----------------|------------------|---------------|---|---|---|---------------|---|-----------|---|---|---|---|--|--|--|--|
|          | Data [31:4]  |    |    |              |                 |            |              |               |            |              |               |            |                     |                    |                   |                   |                  |               |                   |                   |                |                  |               |   |   |   | Address [3:0] |   |           |   |   |   |   |  |  |  |  |
| R0       | 0            | 1  | 0  | 0            | 1               | 0          | 0            | 0             | CLKin1_MUX | CLKin1_DIV   | CLKin0_MUX    | CLKin0_DIV | 1                   | 1                  | CLKin1_BUF_TYPE   | CLKin0_BUF_TYPE   | CLKout12_13_PD   | CLKout8_11_PD | CLKout4_7_PD      | CLKout0_3_PD      | POWERDOWN      | RESET            | 0             | 0 | 0 | 0 |               |   |           |   |   |   |   |  |  |  |  |
| R1       | CLKout7_TYPE |    |    | CLKout6_TYPE |                 |            | CLKout5_TYPE |               |            | CLKout4_TYPE |               |            | CLKout3_TYPE        | CLKout2_TYPE       | CLKout1_TYPE      | CLKout0_TYPE      | 0                | 0             | 0                 | 1                 |                |                  |               |   |   |   |               |   |           |   |   |   |   |  |  |  |  |
| R2       | 0            | 0  | 0  | 0            | CLKout13_TYPE   |            |              | CLKout12_TYPE |            |              | CLKout11_TYPE |            |                     | CLKout10_TYPE      |                   | CLKout9_TYPE      |                  | CLKout8_TYPE  |                   | 0                 | 0              | 1                | 0             |   |   |   |               |   |           |   |   |   |   |  |  |  |  |
| R3       | 0            | 0  | 0  | 1            | 0               | SYNC1_AUTO | SYNC0_AUTO   | SYNC1_FAST    | SYNC0_FAST | 0            | 1             | 1          | NO_SYNC_CLKout12_13 | NO_SYNC_CLKout8_11 | NO_SYNC_CLKout4_7 | NO_SYNC_CLKout0_3 | SYNC1_POL_INV    | SYNC0_POL_INV | 0                 | SYNC1_QUAL        | CLKout12_13_HS | CLKout12_13_ADLY |               |   |   | 0 | 0             | 1 | 1         |   |   |   |   |  |  |  |  |
| R4       | 0            | 0  | 0  | 0            | 0               | 0          | 0            | 0             | 0          | 0            | 0             | 0          | 0                   | 0                  | 0                 | 0                 | CLKout12_13_DDLY |               |                   |                   |                |                  |               |   |   |   | 0             | 1 | 0         | 0 |   |   |   |  |  |  |  |
| R5       | 0            | 0  | 0  | 0            | CLKout12_13_DIV |            |              |               |            |              |               |            |                     |                    |                   |                   | 0                | 0             | CLKout13_ADLY_SEL | CLKout12_ADLY_SEL | CLKout8_11_DIV | CLKout4_7_DIV    | CLKout0_3_DIV | 0 | 1 | 0 | 1             |   |           |   |   |   |   |  |  |  |  |
| R15      | 0            | 0  | 0  | 0            | 0               | 0          | 0            | 0             | 0          | 0            | 0             | 0          | 0                   | 0                  | 0                 | 0                 | 0                | 0             | 0                 | 0                 | 0              | 1                | 0             | 1 | 1 | 1 | 1             | 1 | uWireLock | 1 | 1 | 1 | 1 |  |  |  |  |

### 8.3 DEFAULT DEVICE REGISTER SETTINGS AFTER POWER ON/RESET

The Default Device Register Settings after Power On/Reset Table below illustrates the default register settings programmed in silicon for the LMK018xx after power on or asserting the reset bit. Capital X and Y represent numeric values.

**Table 8-2. Default Device Register Settings after Power On/Reset**

| Field Name          | Default Value (decimal) | Default State               | Field Description   | Register | Bit Location (MSB:LSB) |
|---------------------|-------------------------|-----------------------------|---|----------|------------------------|
| RESET               | 0                       | Not in reset                | Performs power on reset for device                              | R0       | 4                      |
| POWERDOWN           | 0                       | Disabled (device is active) | Device power down control                                       | R0       | 5                      |
| CLKout0_3_PD        | 0                       | Disabled                    | Power down the divider and clock outputs 0 through 3            | R0       | 6                      |
| CLKout4_7_PD        | 0                       | Disabled                    | Power down the divider and clock outputs 4 through 7            | R0       | 7                      |
| CLKout8_11_PD       | 0                       | Disabled                    | Power down the divider and clock outputs 8 through 11           | R0       | 8                      |
| CLKout12_13_PD      | 0                       | Disabled                    | Power down the divider and clock outputs 12 through 13          | R0       | 9                      |
| CLKin0_BUF_TYPE     | 0                       | Bipolar                     | Clock in buffer type  | R0       | 10                     |
| CLKin1_BUF_TYPE     | 0                       | Bipolar                     | Clock in buffer type  | R0       | 11                     |
| CLKin0_DIV          | 2                       | Divide by 2                 | Divider value for CLKin0  | R0       | 14:16 [3]              |
| CLKin0_MUX          | 0                       | Bypass                      | Enables or bypasses the CLKin0 divider                          | R0       | 17:18 [2]              |
| CLKin1_DIV          | 2                       | Divide by 2                 | Divider value for CLKin1  | R0       | 19:21 [3]              |
| CLKin1_MUX          | 0                       | Bypass                      | Enables or bypasses the CLKin1 divider                          | R0       | 22:23 [2]              |
| CLKout0_TYPE        | 1                       | LVDS                        | Individual clock output format. Select from LVDS/LVPECL.        | R1       | 4:6 [3]                |
| CLKout1_TYPE        | 1                       | LVDS                        |   | R1       | 7:9 [3]                |
| CLKout2_TYPE        | 1                       | LVDS                        |   | R1       | 10:12 [3]              |
| CLKout3_TYPE        | 1                       | LVDS                        |   | R1       | 13:15 [3]              |
| CLKout4_TYPE        | 1                       | LVDS                        |   | R1       | 16:19 [4]              |
| CLKout5_TYPE        | 1                       | LVDS                        |   | R1       | 20:23 [4]              |
| CLKout6_TYPE        | 1                       | LVDS                        |   | R1       | 24:27 [4]              |
| CLKout7_TYPE        | 1                       | LVDS                        |   | R1       | 28:31 [4]              |
| CLKout8_TYPE        | 1                       | LVDS                        | Individual clock output format. Select from LVDS/LVPECL/LVCMOS. | R2       | 4:7 [4]                |
| CLKout9_TYPE        | 1                       | LVDS                        |   | R2       | 8:11 [4]               |
| CLKout10_TYPE       | 1                       | LVDS                        |   | R2       | 12:15 [4]              |
| CLKout11_TYPE       | 1                       | LVDS                        |   | R2       | 16:19 [4]              |
| CLKout12_TYPE       | 1                       | LVDS                        |   | R2       | 20:23 [4]              |
| CLKout13_TYPE       | 1                       | LVDS                        |   | R2       | 24:27 [4]              |
| CLKout12_13_ADLY    | 0                       | No delay                    | Analog delay setting for CLKout12 & CLKout13.                   | R3       | 4:9 [6]                |
| CLKout12_13_HS      | 0                       | No Shift                    | Half shift for digital delay.                                   | R3       | 10                     |
| SYNC1_QUAL          | 0                       | Not Qualified               | Allows SYNC operations to be qualified by a clock output        | R3       | 11:12 [2]              |
| SYNC0_POL_INV       | 1                       | Logic Low                   | Sets the polarity of the SYNC pin when input                    | R3       | 14                     |
| SYNC1_POL_INV       | 1                       | Logic Low                   |   | R3       | 15                     |
| NO_SYNC_CLKout0_3   | 0                       | Will sync                   | Disable individual clock groups from being synchronized.        | R3       | 16                     |
| NO_SYNC_CLKout4_7   | 0                       | Will sync                   |   | R3       | 17                     |
| NO_SYNC_CLKout8_11  | 0                       | Will sync                   |   | R3       | 18                     |
| NO_SYNC_CLKout12_13 | 0                       | Will sync                   |   | R3       | 19                     |

**Table 8-2. Default Device Register Settings after Power On/Reset (continued)**

| Field Name        | Default Value (decimal) | Default State  | Field Description                                  | Register | Bit Location (MSB:LSB) |
|-------------------|-------------------------|----------------|--|----------|------------------------|
| SYNC0_FAST        | 0                       | Disabled       | Enables synchronization circuitry.                 | R3       | 23                     |
| SYNC1_FAST        | 0                       | Disabled       |  | R3       | 24                     |
| SYNC0_AUTO        | 1                       | Automatic      | SYNC is started by programming a Register R5       | R3       | 25                     |
| SYNC1_AUTO        | 1                       | Automatic      | SYNC is started by programming a Register R4 or R5 | R3       | 26                     |
| CLKout12_13_DDLY  | 5                       | 5 clock cycles | Digital Delay setting for CLKout12 & CLKout13.     | R4       | 4:13 [10]              |
| CLKout0_3_DIV     | 1                       | Divide-by-1    | Divider for clock outputs.                         | R5       | 4:6 [3]                |
| CLKout4_7_DIV     | 1                       | Divide-by-1    |  | R5       | 7:9 [3]                |
| CLKout8_11_DIV    | 1                       | Divide-by-1    |  | R5       | 10:12 [3]              |
| CLKout12_ADLY_SEL | 0                       | No Delay       | Enable Digital Delay for CLKout12                  | R5       | 13                     |
| CLKout13_ADLY_SEL | 0                       | No Delay       | Enable Digital Delay for CLKout 13                 | R5       | 14                     |
| CLKout12_13_DIV   | 1                       | Divide-by-1    | Divider for clock output.                          | R5       | 17:27 [11]             |
| uWireLock         | 0                       | Writeable      | The values of registers R0 to R5 are lockable      | R15      | 4                      |

## 8.4 REGISTER R0

The R0 register controls reset, global power down, the power down functions for the channel dividers and their corresponding outputs, CLKinX divider value and CLKinX divide select. The X, Y in CLKoutX\_Y\_PD denote the actually clock output which may be from 0 to 13 where X is the first CLKout and Y is the last CLKout.

### 8.4.1 RESET

Setting this bit will cause the silicon default values to be set upon loading of R0 by a high LEuWire pin. When programming register R0 with the RESET bit set, all other programmed values are ignored.

The RESET bit is automatically cleared upon writing any other register. For instance, when R0 is written to again with default values.

If the user reprograms the R0, after the initial programming then set RESET = 0.

**Table 8-3. RESET**

| R0[4] | State                         |
|-------|-------------------------------|
| 0     | Normal operation              |
| 1     | Reset (automatically cleared) |

### 8.4.2 POWERDOWN

Setting this bit causes the device to enter powerdown mode. Normal operation is resumed by clearing this bit with MICROWIRE. All other MICROWIRE settings are preserved during POWERDOWN.

**Table 8-4. POWERDOWN**

| R1[5] | State            |
|-------|------------------|
| 0     | Normal operation |
| 1     | Powerdown        |

### 8.4.3 CLKoutX\_Y\_PD

This bit powers down the clock outputs as specified by CLKoutX to CLKoutY. This includes the divider and output buffers.

**Table 8-5. CLKoutX\_Y\_PD Programming Addresses**

| CLKoutX_Y_PD   | Programming Address |
|----------------|---------------------|
| CLKout0_3_PD   | R0[6]               |
| CLKout4_7_PD   | R0[7]               |
| CLKout8_11_PD  | R0[8]               |
| CLKout12_13_PD | R0[9]               |

**Table 8-6. CLKoutX\_Y\_PD**

| R0[6,7,8,9] | State                  |
|-------------|------------------------|
| 0           | Power up clock group   |
| 1           | Power down clock group |

#### 8.4.3.1 CLKinX\_BUF\_TYPE

There are two input buffer types for CLKin0 and CLKin1: bipolar or CMOS. Bipolar is recommended for differential inputs such as LVDS and LVPECL. CMOS is recommended for DC coupled single ended inputs.

When using bipolar, CLKinX and CLKinX\* input pins must be AC coupled when using differential or single ended input.

When using CMOS, CLKinX and CLKinX\* input pins may be AC or DC coupled with a differential input.

When using CMOS in a single ended mode, the used clock input pin (CLKinX or CLKinX\*) may be AC or DC coupled to the signal source. The unused CLKin should be AC coupled to ground.

The programming address table shows at what register the specified CLKinX\_BUF\_TYPE is located.

The CLKinX\_BUF\_TYPE table shows the programming definition for these registers.

**Table 8-7. CLKinX\_BUF\_TYPE Programming Addresses**

| CLKinX_BUF_TYPE | Programming Address |
|-----------------|---------------------|
| CLKin0_BUF_TYPE | R0[10]              |
| CLKin1_BUF_TYPE | R0[11]              |

**Table 8-8. CLKinX\_BUF\_TYPE**

| R0[10] | CLKinX Buffer Type |
|--------|--------------------|
| 0      | Bipolar            |
| 1      | CMOS               |

#### 8.4.3.2 CLKinX\_DIV

These set the CLKin divide value, from 2-8.

**Table 8-9. CLKinX\_DIV Programming Address**

| CLKinX_DIV | Programming Address |
|------------|---------------------|
| CLKin0_DIV | R0[16:14]           |
| CLKin1_DIV | R0[21:19]           |

**Table 8-10. CLKinX\_DIV**

| R0[21:19, 16:14] | Divide Value |
|------------------|--------------|
| 0 (0x00)         | 8            |
| 1 (0x01)         | 2            |
| 2 (0x02)         | 2            |
| 3 (0x03)         | 3            |
| 4 (0x04)         | 4            |
| 5 (0x05)         | 5            |
| 6 (0x06)         | 6            |
| 7 (0x07)         | 7            |

### 8.4.3.3 CLKinX\_MUX

These bits select whether or not the CLKin divider is bypassed or enabled.

**Table 8-11. CLKinX\_MUX Programming Address**

| CLKinX_MUX | Programming Address |
|------------|---------------------|
| CLKin0_MUX | R0[18:17]           |
| CLKin1_MUX | R0[23:22]           |

**Table 8-12. CLKinX\_MUX**

| R0[23:22, 18:17] | State  |
|------------------|--------|
| 0 (0x00)         | Bypass |
| 1(0x01)          | Divide |

## 8.5 REGISTER R1 AND R2

Registers R1 and R2 set the clock output types.

### 8.5.1 CLKoutX\_TYPE

The clock output types of the LMK01801 are individually programmable. The CLKoutX\_TYPE registers set the output type of an individual clock output to LVDS, LVPECL, LVCMOS, or powers down the output buffer. Note that LVPECL supports three different amplitude levels and LVCMOS supports single LVCMOS outputs, inverted, and normal polarity of each output pin for maximum flexibility.

The programming addresses table shows at what register and address the specified clock output CLKoutX\_TYPE register is located.

The CLKoutX\_TYPE table shows the programming definition for these registers.

**Table 8-13. CLKoutX\_TYPE Programming Addresses**

| CLKoutX  | Programming Address |
|----------|---------------------|
| CLKout0  | R1[4:6]             |
| CLKout1  | R1[7:9]             |
| CLKout2  | R1[10:12]           |
| CLKout3  | R1[13:15]           |
| CLKout4  | R1[16:19]           |
| CLKout5  | R1[20:23]           |
| CLKout6  | R1[24:27]           |
| CLKout7  | R1[28:31]           |
| CLKout8  | R2[4:7]             |
| CLKout9  | R2[8:11]            |
| CLKout10 | R2[12:15]           |
| CLKout11 | R2[16:19]           |
| CLKout12 | R2[20:23]           |
| CLKout13 | R2[24:27]           |

**Table 8-14. CLKoutX\_TYPE, 4 bits**

| R1[31:28,27:24,23:20,19:16],<br>R2[27:24,23:20,19:16,15:12,11:8,7:4] | Definition          |
|--|---------------------|
| 0 (0x00)   | Powerdown           |
| 1 (0x01)   | LVDS                |
| 2 (0x02)   | LCPECL              |
| 3 (0x03)   | Reserved            |
| 4 (0x04)   | LVPECL (1600 mVpp)  |
| 5 (0x05)   | LVPECL (2000 mVpp)  |
| 6 (0x06)   | LVC MOS (Norm/Inv)  |
| 7 (0x07)   | LVC MOS (Inv/Norm)  |
| 8 (0x08)   | LVC MOS (Norm/Norm) |
| 9 (0x09)   | LVC MOS (Inv/Inv)   |
| 10 (0x0A)  | LVC MOS (Off/Norm)  |
| 11 (0x0A)  | LVC MOS (Off/Inv)   |
| 12 (0x0C)  | LVC MOS (Norm/Off)  |
| 13 (0x0D)  | LVC MOS (Inv/Off)   |
| 14 (0x0E)  | LVC MOS (Off/Off)   |



## 8.6 REGISTER R3

Register R3 sets the analog delay, digital delay half-shift and SYNC controls.

### 8.6.1 CLKout12\_13\_ADLY

This registers controls the analog delay of the clock outputs 12 and 13. Adding analog delay to the output will increase the noise floor of the output. For this analog delay to be active for a clock output, it must be selected with ADLY12\_SEL or ADLY13\_SEL. If neither clock output selects the analog delay, then the analog delay block is powered down.

In addition to the programmed delay, a fixed 500 ps of delay will be added by engaging the delay block.

The CLKout12\_13\_ADLY table shows the programming definition for these registers.

**Table 8-15. CLKout12\_13\_ADLY, 6bits**

| R3[4:9]   | Definition        |
|-----------|-------------------|
| 0 (0x00)  | 500 ps + No delay |
| 1 (0x01)  | 500 ps + 25 ps    |
| 2 (0x02)  | 500 ps + 50 ps    |
| 3 (0x03)  | 500 ps + 75 ps    |
| 4 (0x04)  | 500 ps + 100 ps   |
| 5 (0x05)  | 500 ps + 125 ps   |
| 6 (0x06)  | 500 ps + 150 ps   |
| 7 (0x07)  | 500 ps + 175 ps   |
| 8 (0x08)  | 500 ps + 200 ps   |
| 9 (0x09)  | 500 ps + 225 ps   |
| 10 (0x0A) | 500 ps + 250 ps   |
| 11 (0x0B) | 500 ps + 275 ps   |
| 12 (0x0C) | 500 ps + 300 ps   |
| 13 (0x0D) | 500 ps + 325 ps   |
| 14 (0x0E) | 500 ps + 350 ps   |
| 15 (0x0F) | 500 ps + 375 ps   |
| 16 (0x10) | 500 ps + 400 ps   |
| 17 (0x11) | 500 ps + 425 ps   |
| 18 (0x12) | 500 ps + 450 ps   |
| 19 (0x13) | 500 ps + 475 ps   |
| 20 (0x14) | 500 ps + 500 ps   |
| 21 (0x15) | 500 ps + 525 ps   |
| 22 (0x16) | 500 ps + 550 ps   |
| 23 (0x17) | 500 ps + 575 ps   |

### 8.6.2 CLKout12\_13\_HS, Digital Delay Half Shift

This bit subtracts a half clock cycle of the clock distribution path period to the digital delay of CLKout12 and CLKout13. CLKout12\_13\_HS is used together with CLKout12\_13\_DDLY to set the digital delay value.

The state of this bit does not affect the power mode of the clock output group.

When changing CLKout12\_13\_HS, the digital delay immediately takes effect without a SYNC event.

**Table 8-16. CLKout12\_13\_HS**

| R3[10] | State  |
|--------|--------|
| 0      | Normal |

**Table 8-16. CLKout12\_13\_HS (continued)**

| R3[10] | State  |
|--------|--|
| 1      | Subtract half of a clock distribution path period from the total digital delay |

### 8.6.3 SYNC1\_QUAL

When SYNC1\_QUAL is set clock outputs on Bank B will be synchronized.

CLKout12 will be used as the SYNC qualification clock.

Only CLKout12 and CLKout13 support dynamic digital delay. However, this permits the relative phase relationship between CLKout 12 and CLKout13 to be dynamically adjusted with respect to all other clock outputs. When NO\_SYNC\_CLKoutX\_Y = 1, the corresponding clock outputs will not be interrupted during the SYNC event.

Qualifying the SYNC means that the pulse which turns the clock outputs off and on will have a fixed time relationship with the phase of the other clock outputs.

See [Section 6.9](#) for more information.

**Table 8-17. SYNC1\_QUAL**

| R3[11]   | Mode                  |
|----------|-----------------------|
| 0 (0x00) | No Qualification      |
| 1 (0x01) | Reserved              |
| 2 (0x10) | Reserved              |
| 3 (0x11) | Qualification Enabled |

### 8.6.4 SYNCX\_POL\_INV

Sets the polarity of a SYNCX input pin. When SYNC is asserted the clock outputs will transition to a low state.

A pull-up on the SYNCX pin results in normal operation when the SYNCX\_POL\_INV = 1 and the SYNCX input is a no connect.

See [Section 7.6](#) for more information on SYNC. A SYNC event can be generated by toggling this bit through the MICROWIRE interface.

**Table 8-18. SYNCX\_POL\_INV**

| R3[14, 15] | Polarity            |
|------------|---------------------|
| 0          | SYNC is active high |
| 1          | SYNC is active low  |

### 8.6.5 NO\_SYNC\_CLKoutX\_Y

The NO\_SYNC\_CLKoutX\_Y bits prevent individual clock groups from becoming synchronized during a SYNC event. A reason to prevent individual clock groups from becoming synchronized is that during synchronization, the clock output is in a fixed low state or can have a glitch pulse.

By disabling SYNC on a clock group, it will continue to operate normally during a SYNC event.

Digital delay requires a SYNC operation to take effect. If NO\_SYNC\_CLKout12\_13 is set before a SYNC event, the digital delay value will be unused.

Setting the NO\_SYNC\_CLKoutX\_Y bit has no effect on clocks already synchronized together.

**Table 8-19. NO\_SYNC\_CLKoutX\_Y Programming Addresses**

| NO_SYNC_CLKoutX_Y    | Programming Address |
|----------------------|---------------------|
| CLKout0 to CLKout3   | R3[16]              |
| CLKout4 to CLKout7   | R3[17]              |
| CLKout8 to CLKout11  | R3[18]              |
| CLKout12 to CLKout13 | R3[19]              |

**Table 8-20. NO\_SYNC\_CLKoutX\_Y**

| R3[19, 18, 17, 16] | Definition                     |
|--------------------|--------------------------------|
| 0                  | CLKoutX_Y will synchronize     |
| 1                  | CLKoutX_Y will not synchronize |

### 8.6.6 SYNCX\_FAST

SYNC1\_FAST must be set to 1 when using SYNC1\_QUAL

### 8.6.7 SYNCX\_AUTO

When set, causes a SYNC event to occur when programming R4 to adjust digital delay values (this will cause a SYNC event for Bank B only) or R5 when adjusting divide values (this will cause a SYNC event for both Bank A and B).

The SYNC event will coincide with the LE uWire pin falling edge.

**Table 8-21. SYNCX\_AUTO**

| R3[26, 25] | Mode                      |
|------------|---------------------------|
| 0          | Manual SYNC               |
| 1          | SYNC internally generated |

## 8.7 REGISTER R4

### 8.7.1 CLKout12\_13\_DDLY, Clock Channel Digital Delay

CLKout12\_13\_DDLY and CLKout12\_13\_HS sets the digital delay used for CLKout12 and CLKout13. CLKout12\_13\_DDLY only takes effect during a SYNC event and if the NO\_SYNC\_CLKout12\_13 bit is cleared for this clock group.

Programming CLKout12\_13\_DDLY can require special attention. See section [Section 7.6.1](#) for more details.

Using a CLKout12\_13\_DDLY value of 13 or greater will cause the clock outputs to operate in extended mode regardless of the clock group's divide value or the half step value.

One clock cycle is equal to the period of the clock distribution path. The period of the clock distribution path is equal to clock divider value divided by the CLKin1 frequency.

$$t_{\text{clock distribution path}} = \text{CLKout divide value} / f_{\text{CLKin}}$$

**Table 8-22. CLKout12\_13\_DDLY, 10 bits**

| R4[13:4]    | Delay<br>(Divide = 1) | Delay<br>(Divide >1) | Power Mode    |
|-------------|-----------------------|----------------------|---------------|
| 0 (0x00)    | 5 clock cycles        | 6 clock cycles       | Normal Mode   |
| 1 (0x01)    | 5 clock cycles        | 6 clock cycles       |               |
| 2 (0x02)    | 5 clock cycles        | 6 clock cycles       |               |
| 3 (0x03)    | 5 clock cycles        | 6 clock cycles       |               |
| 4 (0x04)    | 5 clock cycles        | 6 clock cycles       |               |
| 5 (0x05)    | 5 clock cycles        | 6 clock cycles       |               |
| 6 (0x06)    | 6 clock cycles        | 7 clock cycles       |               |
| 7 (0x07)    | 7 clock cycles        | 8 clock cycles       |               |
| ...         | ...                   | ...                  |               |
| 12 (0x0C)   | 12 clock cycles       | 13 clock cycles      |               |
| 13 (0x0D)   | 13 clock cycles       | 14 clock cycles      | Extended Mode |
| ...         | ...                   | ...                  |               |
| 520 (0x208) | 520 clock cycles      | 521 clock cycles     |               |
| 521 (0x209) | 521 clock cycles      | 522 clock cycles     |               |
| 522 (0x20A) | 522 clock cycles      | 523 clock cycles     |               |

## 8.8 REGISTER R5

Register 5 sets the clock output dividers and analog delay.

### 8.8.1 CLKout12\_ADLY\_SEL[13], CLKout13\_ADLY\_SEL[14], Select Analog Delay

These bits individually select the analog delay block for use with CLKout12 or CLKout13. It is not required for both outputs of a clock output group to use analog delay, but if both outputs do select the analog delay block, then the analog delay will be the same for each output. When neither clock output uses analog delay, the analog delay block is powered down.

**Table 8-23. CLKout12\_ADLY\_SEL[13], CLKout13\_ADLY\_SEL[14]**

| R5[13] | R5[14] | State                        |
|--------|--------|------------------------------|
| 0      | 0      | Analog delay powered down    |
| 0      | 1      | Analog delay on CLKout13     |
| 1      | 0      | Analog delay on CLKout12     |
| 1      | 1      | Analog delay on both CLKouts |

### 8.8.2 CLKoutX\_Y\_DIV. Clock Output Divide

CLKoutX\_Y\_DIV sets the divide value for the clock outputs X through Y. The divide may be even or odd. Both even and odd divides output a 50% duty cycle clock.

Programming CLKoutX\_Y\_DIV is as follows:

**Table 8-24. CLKoutX\_Y\_DIV Programming Addresses**

| CLKoutX_Y_DIV   | Programming Address |
|-----------------|---------------------|
| CLKout0_3_DIV   | R5[6:4]             |
| CLKout4_7_DIV   | R5[9:7]             |
| CLKout8_11_DIV  | R5[12:10]           |
| CLKout12_13_DIV | R5[27:17]           |

**Table 8-25. CLKoutX\_Y\_Div, 2 bits**

| R5[12:10, 9:7, 6:4] | Divide Value |
|---------------------|--------------|
| 0 (0x00)            | 8            |
| 1 (0x01)            | 1            |
| 2 (0x02)            | 2            |
| 3 (0x03)            | 3            |
| 4 (0x04)            | 4            |
| 5 (0x05)            | 5            |
| 6 (0x06)            | 6            |
| 7 (0x07)            | 7            |

**Table 8-26. CLKout12\_13\_DIV, 11 bits**

| R5[27:17]    | Divide Value     | Power Mode    |
|--------------|------------------|---------------|
| 0 (0x00)     | Invalid          | Normal Mode   |
| 1 (0x01)     | 1                |               |
| 2 (0x02)     | 2 <sup>(1)</sup> |               |
| 3 (0x03)     | 3                |               |
| 4 (0x04)     | 4 <sup>(1)</sup> |               |
| 5 (0x05)     | 5 <sup>(1)</sup> |               |
| 6 (0x06)     | 6                |               |
| ...          | ...              |               |
| 24 (0x18)    | 24               |               |
| 25 (0x19)    | 25               |               |
| 26 (0x1A)    | 26               | Extended Mode |
| 27 (0x1B)    | 27               |               |
| ...          | ...              |               |
| 1044 (0x414) | 1044             |               |
| 1045 (0x415) | 1045             |               |

(1) After programming CLKout12\_13\_DIV a SYNC event must occur on the channels using this divide value (CLKout 12 and CLKout13). A SYNC event may be generated by changing the SYNC1\_POL\_INV bit or through the SYNC1 pin. Ensure that CLKin1 is stable before this SYNC event occurs.

Using a divide value of 26 or greater will cause the clock group to operate in extended mode regardless of the clock group's digital delay value.

## 8.9 REGISTER 15

### 8.9.1 uWireLock

Setting uWireLock will prevent any changes to uWire registers R0 to R5. Only by clearing uWireLock bit in R15 can the MICROWIRE registers be unlocked and written to once more.

**Table 8-27. uWireLock**

| R15 [4] | State                             |
|---------|-----------------------------------|
| 0       | Registers Unlocked                |
| 1       | Registers locked, Write-protected |

## 9 Application Information

### 9.1 POWER SUPPLY

#### 9.1.1 Current Consumption

---

#### NOTE

Assuming  $\theta_{JA} = 25.8 \text{ }^\circ\text{C/W}$ , the total power dissipated on chip must be less than  $(125 \text{ }^\circ\text{C} - 85 \text{ }^\circ\text{C}) / 25.8 \text{ }^\circ\text{C/W} = 1.5 \text{ W}$  to ensure a junction temperature less than  $145 \text{ }^\circ\text{C}$ .

Worst case power dissipation can be estimated by multiplying typical power dissipation with a factor of 1.20.

---

From [Table 9-1](#) the current consumption can be calculated for any configuration.

For example, the current for the entire device with 1 LVDS (CLKout0) and 1 LVPECL 1600 mVpp /w 240  $\Omega$  emitter resistors (CLKout1) output active with a clock output divide = 1, and no other features enabled can be calculated by adding the following blocks:

- Core Current
- Clock Buffer
- One LVDS Output Buffer Current
- Bank A
- Output Divider Buffer Current
- LVPECL 1600 mVpp buffer /w 240  $\Omega$  emitter resistors

Since there will be one LVPECL output drawing emitter current, this means some of the power from the current draw of the device is dissipated in the external emitter resistors which doesn't add to the power dissipation budget for the device but is important for LDO  $I_{CC}$  calculations.

For total current consumption of the device add up the significant functional blocks. In this example 92 mA =

- 1 mA (core current)
- 22 mA (Bank A current)
- 15 mA (Output Buffer current)
- 21 mA (Output Divider current)
- 9 mA (LVDS output current)
- 24 mA (LVPECL 1600 mVpp buffer /w 240  $\Omega$  emitter resistors)

Once the total current consumption has been calculated, power dissipated by the device can be calculated. The power dissipation of the device is equal to the total current entering the device multiplied by the voltage at the device minus the power dissipated in any emitter resistors connected to any of the LVPECL outputs. If no emitter resistors are connected to the LVPECL outputs, this power will be 0 watts. Continuing the output with 240  $\Omega$  emitter resistors. Total IC power =  $275.1 \text{ mW} = 3.3 \text{ V} * 95 \text{ mA} - 28.5 \text{ mW}$ .

**Table 9-1. Typical Current Consumption for Selected Functional Blocks**  
( $T_A = 25\text{ }^\circ\text{C}$ ,  $V_{CC} = 3.3\text{ V}$ )

| Block                       | Condition   | Typical $I_{CC}$ (mA)                         | Power dissipated in device (mW) | Power dissipated externally (mW) <sup>(1)</sup> |   |
|-----------------------------|---|---|---------------------------------|---|---|
| <b>Core</b>                 |   |   |                                 |   |   |
| Core                        | All outputs and dividers off  | 1   | 3.3                             | -   |   |
| Bank                        | Bank A  | At least on output enabled                    | 22                              | 72.6  | - |
|                             | Bank B  | At least on output enabled                    | 25                              | 82.5  | - |
| Buffers                     | CLKout0 to CLKout3  | On when any on output in the group is enabled | 15                              | 49.5  | - |
|                             | CLKout4 to CLKout7  |   |                                 |   | - |
|                             | CLKout8 to CLKout11   |   |                                 |   | - |
|                             | CLKout12 to CLKout13  |   |                                 |   | - |
| Output Divider              | CLKout0 to CLKout11   | Divide = 1                                    | 21                              | 69.3  | - |
|                             |   | Divide = 2 to 8                               | 24.2                            | 79.8  | - |
|                             | CLKout12 and CLKout13   | Divide = 1 to 25 and DDLY = 1 to 12           | 15                              | 49.5  | - |
|                             |   | Divide = 26 to 1045 or DDLY > 13              | 19.1                            | 63.0  | - |
| Input Divider               | Bank A  | Divide = 2 to 8                               | 9                               | 29.7  | - |
|                             | Bank B  | Divide = 2 to 8                               |                                 |   | - |
| Analog Delay                | Analog Delay Value  | CLKout12_13_ADLY = 0 to 3                     | 3.4                             | 11.2  | - |
|                             |   | CLKout12_13_ADLY = 4 to 7                     | 3.8                             | 12.5  | - |
|                             |   | CLKout12_13_ADLY = 8 to 11                    | 4.2                             | 13.9  | - |
|                             |   | CLKout12_13_ADLY = 12 to 15                   | 4.7                             | 15.5  | - |
|                             |   | CLKout12_13_ADLY = 16 to 23                   | 5.2                             | 17.2  | - |
|                             | When only one, CLKout12 or CLKout13, have Analog Delay Selected.                        | 2.8   | 9.2                             | -   |   |
| <b>Clock Output Buffers</b> |   |   |                                 |   |   |
| LVDS                        | CLKout0 to CLKout11; 100 $\Omega$ differential termination                              | 9   | 29.7                            | -   |   |
|                             | CLKout12 to CLKout13; 100 $\Omega$ differential termination                             | 14  | 46.2                            | -   |   |
| LVPECL                      | CLKout0 to CLKout11; LVPECL 1600 mVpp, AC coupled using 240 $\Omega$ emitter resistors  | 24  | 79.2                            | 28.5  |   |
|                             | CLKout12 to CLKout13; LVPECL 1600 mVpp, AC coupled using 240 $\Omega$ emitter resistors | 29.5  | 97.3                            | 28.5  |   |
| LVCMOS                      | LVCMOS Pair, CLKout4 to CLKout11, (CLKoutX_TYPE = 6 - 10), $C_L = 5\text{ pF}$          | 10 MHz  | 18.6                            | 61.4  | - |
|                             |   | 50 MHz  | 23.1                            | 76.2  | - |
|                             |   | 150 MHz                                       | 31.7                            | 104.6   | - |
|                             | LVCMOS Pair, CLKout12 and CLKout13, (CLKoutX_TYPE = 6 - 10), $C_L = 5\text{ pF}$        | 10 MHz  | 24.7                            | 81.51   | - |
|                             |   | 50 MHz  | 30.3                            | 100   | - |
|                             |   | 150 MHz                                       | 42.0                            | 138.6   | - |
|                             | LVCMOS Single, CLKout4 to CLKout11, (CLKoutX_TYPE = 11 - 13), $C_L = 5\text{ pF}$       | 10 MHz  | 9.7                             | 32  | - |
|                             |   | 50 MHz  | 10.8                            | 35.6  | - |
|                             |   | 150 MHz                                       | 13.5                            | 44.5  | - |
|                             | LVCMOS Single, CLKout12 and CLKout13, (CLKoutX_TYPE = 11 - 13), $C_L = 5\text{ pF}$     | 10 MHz  | 15                              | 49.5  | - |
|                             |   | 50 MHz  | 17.5                            | 57.7  | - |
|                             |   | 150 MHz                                       | 22.8                            | 75.2  | - |

(1) Power is dissipated externally in LVPECL emitter resistors. The externally dissipated power is calculated as twice the DC voltage level of one LVPECL clock output pin squared over the emitter resistance. That is to say power dissipated in emitter resistors =  $2 * V_{em}^2 / R_{em}$

## 9.2 PIN CONNECTION RECOMMENDATIONS

### 9.2.1 *Vcc Pins and Decoupling*

All Vcc pins must always be connected.

Integrated capacitance on the IC makes high frequency decoupling capacitors unnecessary. Ferrite beads should be used on CLKout Vcc pins to minimize crosstalk through power supply. When several clocks share the same frequency, a single ferrite bead can be shared with the common frequency CLKout Vcc's for power supply isolation.

### 9.2.2 *Unused clock outputs*

Leave unused clock outputs floating and powered down.

### 9.2.3 *Unused clock inputs*

Unused clock inputs can be left floating.

### 9.2.4 *Bias*

Proper bypassing of the Bias pin with a 1  $\mu$ F capacitor connected to Vcc4\_Bias (Pin 25) is important for low noise performance.

### 9.2.5 *In MICROWIRE Mode*

SYNC0 and SYNC1 have an internal pullup and may be left as a no-connect if external SYNC is not required. MIRCROWIRE SYNC may still be used in this condition.

## 9.3 THERMAL MANAGEMENT

Power consumption of the LMK01801 can be high enough to require attention to thermal management. For reliability and performance reasons the die temperature should be limited to a maximum of 125 °C. That is, as an estimate, TA (ambient temperature) plus device power consumption times  $\theta_{JA}$  should not exceed 125 °C.

The package of the device has an exposed pad that provides the primary heat removal path as well as excellent electrical grounding to a printed circuit board. To maximize the removal of heat from the package a thermal land pattern including multiple vias to a ground plane must be incorporated on the PCB within the footprint of the package. The exposed pad must be soldered down to ensure adequate heat conduction out of the package.

A recommended footprint including recommended solder mask and solder paste layers can be found at: <http://www.ti.com/packaging> for the RHS0048A package.



## 9.4 DRIVING CLKin INPUTS

### 9.4.1 Driving CLKin Pins with a Differential Source

Both CLKin ports can be driven by differential signals. It is recommended that the input mode be set to bipolar (CLKinX\_BUF\_TYPE = 0) when using differential reference clocks. The LMK01801 family internally biases the input pins so the differential interface should be AC coupled. The recommended circuits for driving the CLKin pins with either LVDS or LVPECL are shown in Figure 9-1 and Figure 9-2.

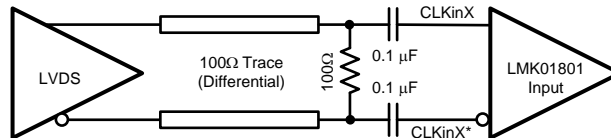


Figure 9-1. CLKinX/X\* Termination for an LVDS Reference Clock Source

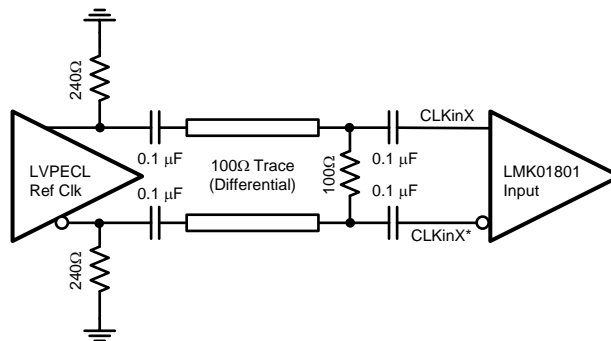


Figure 9-2. CLKinX/X\* Termination for an LVPECL Reference Clock Source

Finally, a reference clock source that produces a differential sine wave output can drive the CLKin pins using the circuit shown in Figure 9-3. Note: the signal level must conform to the requirements for the CLKin pins listed in the Section 3.4.

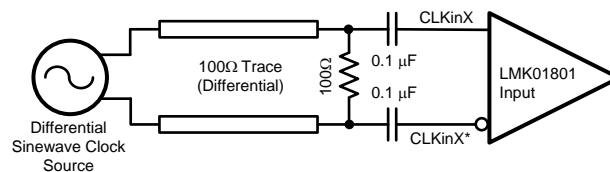


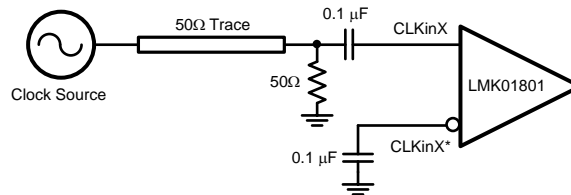
Figure 9-3. CLKinX/X\* Single-ended Termination

### 9.4.2 Driving CLKin Pins with a Single-Ended Source

The CLKin pins of the LMK01801 family can be driven using a single-ended reference clock source, for example, either a sine wave source or an LVCMOS/LVTTL source. Either AC coupling or DC coupling may be used. In the case of the sine wave source that is expecting a 50 Ω load, it is recommended that AC coupling be used as shown in Figure 9-4 the circuit below with a 50 Ω termination.

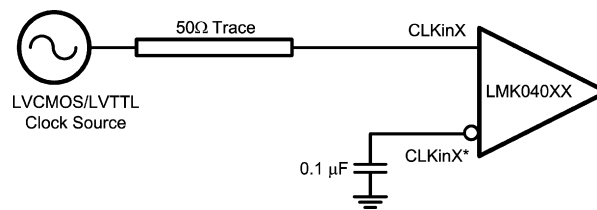
#### NOTE

The signal level must conform to the requirements for the CLKin pins listed in the Section 3.4. CLKinX\_BUF\_TYPE is recommended to be set to bipolar mode (CLKinX\_BUF\_TYPE = 0).



**Figure 9-4. DC Coupled LVCMOS/LVTTL Reference Clock**

If the CLKin pins are being driven with a single-ended LVCMOS/ LVTTL source, either DC coupling or AC coupling may be used. If DC coupling is used, see [Figure 9-5](#), the CLKinX\_BUF\_TYPE should be set to MOS buffer mode (CLKinX\_BUF\_TYPE = 1) and the voltage swing of the source must meet the specifications for DC coupled, MOS-mode clock inputs given in the table of Electrical Characteristics. If AC coupling is used, the CLKinX\_BUF\_TYPE should be set to the bipolar buffer mode (CLKinX\_BUF\_TYPE = 0). The voltage swing at the input pins must meet the specifications for AC coupled, bipolar mode clock inputs given in the table of Electrical Characteristics. In this case, some attenuation of the clock input level may be required. A simple resistive divider circuit before the AC coupling capacitor is sufficient.



**Figure 9-5. DC Coupled LVCMOS/LVTTL Reference Clock**

## 9.5 TERMINATION AND USE OF CLOCK OUTPUT (DRIVERS)

When terminating clock drivers keep in mind these guidelines for optimum phase noise and jitter performance:

- Transmission line theory should be followed for good impedance matching to prevent reflections.
- Clock drivers should be presented with the proper loads. For example:
  - LVDS drivers are current drivers and require a closed current loop.
  - LVPECL drivers are open emitters and require a DC path to ground.
- Receivers should be presented with a signal biased to their specified DC bias level (common mode voltage) for proper operation. Some receivers have self-biasing inputs that automatically bias to the proper voltage level. In this case, the signal should normally be AC coupled.

It is possible to drive a non-LVPECL or non-LVDS receiver with an LVDS or LVPECL driver as long as the above guidelines are followed. Check the datasheet of the receiver or input being driven to determine the best termination and coupling method to be sure that the receiver is biased at its optimum DC voltage (common mode voltage).

For example, when driving the OSCin/OSCin\* input of the LMK04800 family, OSCin/OSCin\* should be AC coupled because OSCin/ OSCin\* biases the signal to the proper DC level. This is only slightly different from the AC coupled cases described in [Section 9.4.2](#) because the DC blocking capacitors are placed between the termination and the OSCin/OSCin\* pins, but the concept remains the same. The receiver (OSCin/OSCin\*) sets the input to the optimum DC bias voltage (common mode voltage), not the driver.

### 9.5.1 Termination for DC Coupled Differential Operation

For DC coupled operation of an LVDS driver, terminate with  $100\ \Omega$  as close as possible to the LVDS receiver as shown in Figure 9-6.

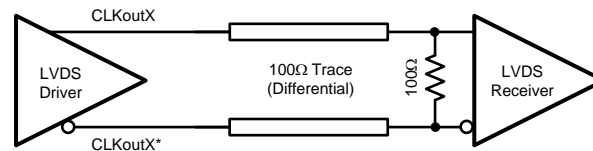


Figure 9-6. Differential LVDS Operation, DC Coupling, No Biasing of the Receiver

For DC coupled operation of an LVPECL driver, terminate with  $50\ \Omega$  to  $V_{CC} - 2\text{ V}$  as shown in Figure 9-7. Alternatively terminate with a Thevenin equivalent circuit ( $120\ \Omega$  resistor connected to  $V_{CC}$  and an  $82\ \Omega$  resistor connected to ground with the driver connected to the junction of the  $120\ \Omega$  and  $82\ \Omega$  resistors) as shown in Figure 9-8 for  $V_{CC} = 3.3\text{ V}$ .

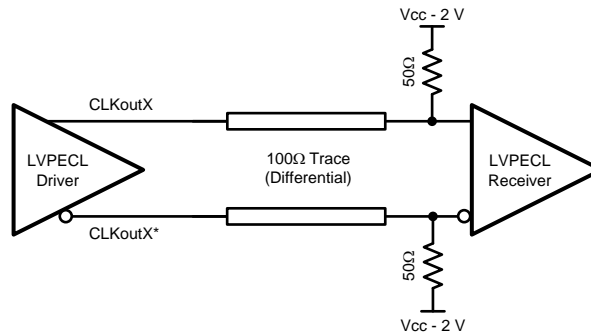


Figure 9-7. Differential LVPECL Operation, DC Coupling

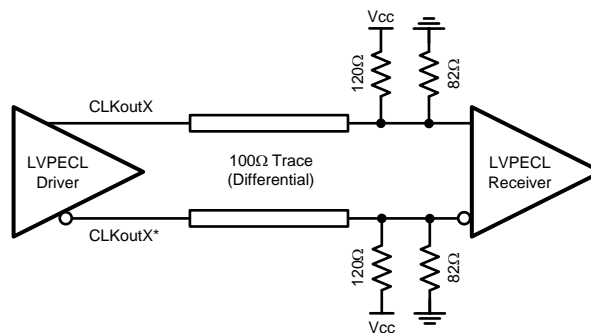
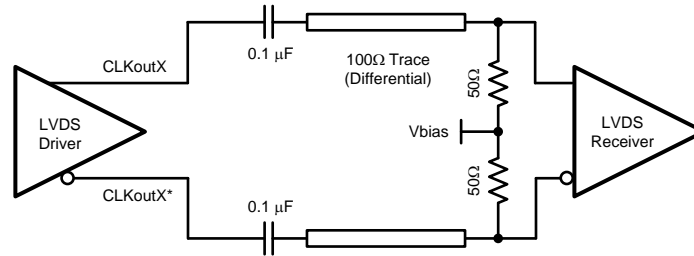


Figure 9-8. Differential LVPECL Operation, DC Coupling, Thevenin Equivalent

### 9.5.2 Termination for AC Coupled Differential Operation

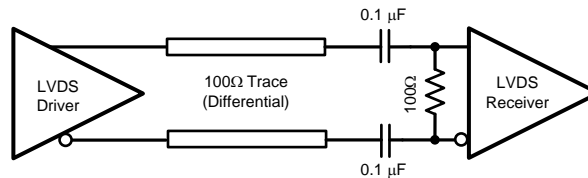
AC coupling allows for shifting the DC bias level (common mode voltage) when driving different receiver standards. Since AC coupling prevents the driver from providing a DC bias voltage at the receiver it is important to ensure the receiver is biased to its ideal DC level.

When driving non-biased LVDS receivers with an LVDS driver, the signal may be AC coupled by adding DC blocking capacitors, however the proper DC bias point needs to be established at the receiver. One way to do this is with the termination circuitry in Figure 9-9.



**Figure 9-9. Differential LVDS Operation, AC Coupling, External Biasing at the Receiver**

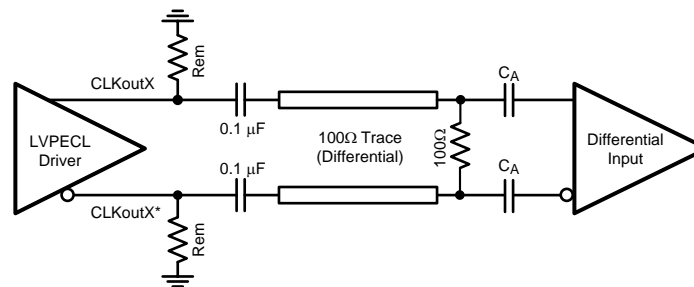
Some LVDS receivers may have internal biasing on the inputs. In this case, the circuit shown in is modified by replacing the 50 Ω terminations to Vbias with a single 100 Ω resistor across the input pins of the receiver, as shown in [Figure 9-10](#). When using AC coupling with LVDS outputs, there may be a startup delay observed in the clock output due to capacitor charging. The previous figures employ a 0.1 μF capacitor. This value may need to be adjusted to meet the startup requirements for a particular application.



**Figure 9-10. LVDS Termination for a Self-Biased Receiver**

LVPECL drivers require a DC path to ground. When AC coupling an LVPECL signal use 120 Ω to 240 Ω emitter resistors close to the LVPECL driver to provide a DC path to ground as shown in [Figure 9-11](#). For proper receiver operation, the signal should be biased to the DC bias level (common mode voltage) specified by the receiver. The typical DC bias voltage for LVPECL receivers is 2 V.

A typical application is shown in [Figure 9-11](#), where  $R_{em}=120\ \Omega$  to  $240\ \Omega$ . Refer to the receiver input recommendations to determine if the proper value of  $C_A$ 's, if needed.

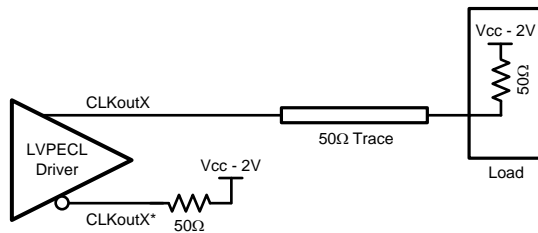


**Figure 9-11. Differential LVPECL Operation, AC Coupling, External Biasing at the Receiver,  $R_{em}=120\ \Omega$  to  $240\ \Omega$**

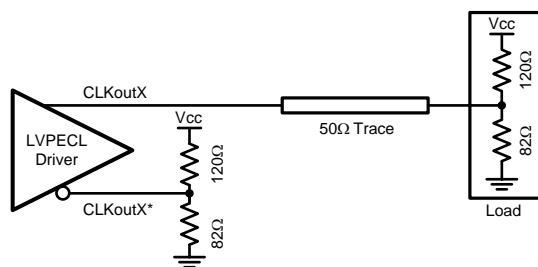
### 9.5.3 Termination for Single-Ended Operation

A balun can be used with either LVDS or LVPECL drivers to convert the balanced, differential signal into an unbalanced, single-ended signal.

It is possible to use an LVPECL driver as one or two separate 800 mVpp signals. When using only one LVPECL driver of a CLKoutX/CLKoutX\* pair, be sure to properly terminate the unused driver. When DC coupling one of the LMK04800 family clock LVPECL drivers, the termination should be  $50\ \Omega$  to  $V_{CC} - 2\text{ V}$  as shown in Figure 9-12. The Thevenin equivalent circuit is also a valid termination as shown in Figure 9-13 for  $V_{CC} = 3.3\text{ V}$ .

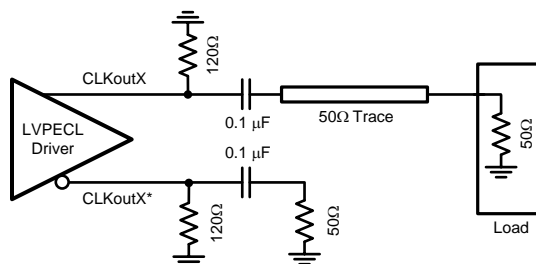


**Figure 9-12. Single-Ended LVPECL Operation, DC Coupling**



**Figure 9-13. Single-Ended LVPECL Operation, DC Coupling, Thevenin Equivalent**

When AC coupling an LVPECL driver use a  $120\ \Omega$  to  $240\ \Omega$  emitter resistor to provide a DC path to ground and ensure a  $50\ \Omega$  termination with the proper DC bias level for the receiver. The typical DC bias voltage for LVPECL receivers is  $2\text{ V}$  (See Section 9.5.2). If the companion driver is not used it should be terminated with either a proper AC or DC termination. This latter example of AC coupling a single-ended LVPECL signal can be used to measure single-ended LVPECL performance using a spectrum analyzer or phase noise analyzer. When using most RF test equipment no DC bias point ( $0\text{ VDC}$ ) is required for safe and proper operation. The internal  $50\ \Omega$  termination of the test equipment correctly terminates the LVPECL driver being measured as shown in Figure 9-14.



**Figure 9-14. Single-Ended LVPECL Operation, AC Coupling**  
 $R_{em} = 120\ \Omega$  to  $240\ \Omega$

---

### Revision History

NOTE: Page numbers for previous revisions may differ from page numbers in the current version.

---

| Changes from Original (April 2013) to Revision A   | Page               |
|--|--------------------|
| <ul style="list-style-type: none"><li>Changed layout of National Data Sheet to TI format .....</li></ul> | <a href="#">45</a> |

---

**PACKAGING INFORMATION**

| Orderable Device   | Status<br>(1) | Package Type | Package Drawing | Pins | Package Qty | Eco Plan<br>(2)         | Lead/Ball Finish | MSL Peak Temp<br>(3) | Op Temp (°C) | Top-Side Markings<br>(4) | Samples                 |
|--------------------|---------------|--------------|-----------------|------|-------------|-------------------------|------------------|----------------------|--------------|--------------------------|-------------------------|
| LMK01801BISQ/NOPB  | ACTIVE        | WQFN         | RHS             | 48   | 1000        | Green (RoHS & no Sb/Br) | CU SN            | Level-3-260C-168 HR  | -40 to 85    | K01801BI                 | <a href="#">Samples</a> |
| LMK01801BISQE/NOPB | ACTIVE        | WQFN         | RHS             | 48   | 250         | Green (RoHS & no Sb/Br) | CU SN            | Level-3-260C-168 HR  | -40 to 85    | K01801BI                 | <a href="#">Samples</a> |
| LMK01801BISQX/NOPB | ACTIVE        | WQFN         | RHS             | 48   | 2500        | Green (RoHS & no Sb/Br) | CU SN            | Level-3-260C-168 HR  | -40 to 85    | K01801BI                 | <a href="#">Samples</a> |

(1) The marketing status values are defined as follows:

**ACTIVE:** Product device recommended for new designs.

**LIFEBUY:** TI has announced that the device will be discontinued, and a lifetime-buy period is in effect.

**NRND:** Not recommended for new designs. Device is in production to support existing customers, but TI does not recommend using this part in a new design.

**PREVIEW:** Device has been announced but is not in production. Samples may or may not be available.

**OBSOLETE:** TI has discontinued the production of the device.

(2) Eco Plan - The planned eco-friendly classification: Pb-Free (RoHS), Pb-Free (RoHS Exempt), or Green (RoHS & no Sb/Br) - please check <http://www.ti.com/productcontent> for the latest availability information and additional product content details.

**TBD:** The Pb-Free/Green conversion plan has not been defined.

**Pb-Free (RoHS):** TI's terms "Lead-Free" or "Pb-Free" mean semiconductor products that are compatible with the current RoHS requirements for all 6 substances, including the requirement that lead not exceed 0.1% by weight in homogeneous materials. Where designed to be soldered at high temperatures, TI Pb-Free products are suitable for use in specified lead-free processes.

**Pb-Free (RoHS Exempt):** This component has a RoHS exemption for either 1) lead-based flip-chip solder bumps used between the die and package, or 2) lead-based die adhesive used between the die and leadframe. The component is otherwise considered Pb-Free (RoHS compatible) as defined above.

**Green (RoHS & no Sb/Br):** TI defines "Green" to mean Pb-Free (RoHS compatible), and free of Bromine (Br) and Antimony (Sb) based flame retardants (Br or Sb do not exceed 0.1% by weight in homogeneous material)

(3) MSL, Peak Temp. -- The Moisture Sensitivity Level rating according to the JEDEC industry standard classifications, and peak solder temperature.

(4) Multiple Top-Side Markings will be inside parentheses. Only one Top-Side Marking contained in parentheses and separated by a "~" will appear on a device. If a line is indented then it is a continuation of the previous line and the two combined represent the entire Top-Side Marking for that device.

**Important Information and Disclaimer:** The information provided on this page represents TI's knowledge and belief as of the date that it is provided. TI bases its knowledge and belief on information provided by third parties, and makes no representation or warranty as to the accuracy of such information. Efforts are underway to better integrate information from third parties. TI has taken and continues to take reasonable steps to provide representative and accurate information but may not have conducted destructive testing or chemical analysis on incoming materials and chemicals. TI and TI suppliers consider certain information to be proprietary, and thus CAS numbers and other limited information may not be available for release.

In no event shall TI's liability arising out of such information exceed the total purchase price of the TI part(s) at issue in this document sold by TI to Customer on an annual basis.

## TAPE AND REEL INFORMATION



### QUADRANT ASSIGNMENTS FOR PIN 1 ORIENTATION IN TAPE



\*All dimensions are nominal

| Device             | Package Type | Package Drawing | Pins | SPQ  | Reel Diameter (mm) | Reel Width W1 (mm) | A0 (mm) | B0 (mm) | K0 (mm) | P1 (mm) | W (mm) | Pin1 Quadrant |
|--------------------|--------------|-----------------|------|------|--------------------|--------------------|---------|---------|---------|---------|--------|---------------|
| LMK01801BISQ/NOPB  | WQFN         | RHS             | 48   | 1000 | 330.0              | 16.4               | 7.3     | 7.3     | 1.3     | 12.0    | 16.0   | Q1            |
| LMK01801BISQE/NOPB | WQFN         | RHS             | 48   | 250  | 178.0              | 16.4               | 7.3     | 7.3     | 1.3     | 12.0    | 16.0   | Q1            |
| LMK01801BISQX/NOPB | WQFN         | RHS             | 48   | 2500 | 330.0              | 16.4               | 7.3     | 7.3     | 1.3     | 12.0    | 16.0   | Q1            |

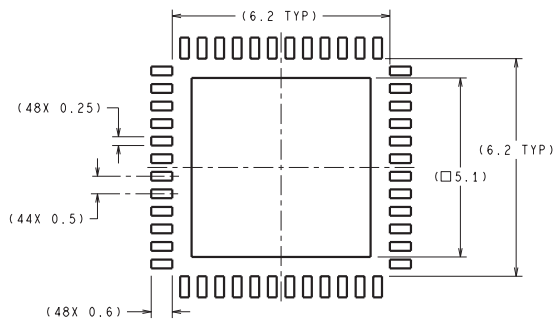


**TAPE AND REEL BOX DIMENSIONS**


\*All dimensions are nominal

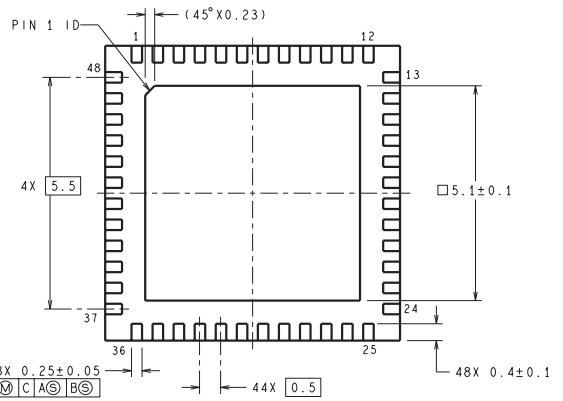
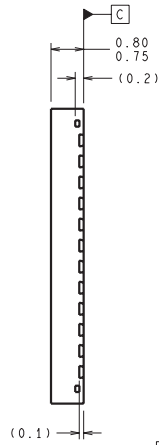
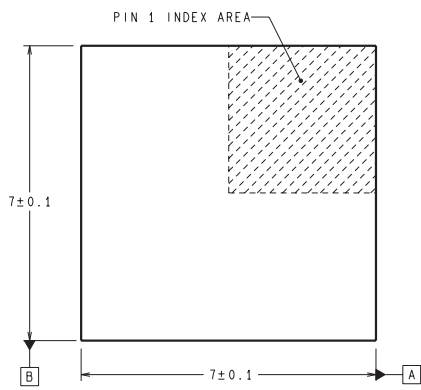
| Device             | Package Type | Package Drawing | Pins | SPQ  | Length (mm) | Width (mm) | Height (mm) |
|--------------------|--------------|-----------------|------|------|-------------|------------|-------------|
| LMK01801BISQ/NOPB  | WQFN         | RHS             | 48   | 1000 | 367.0       | 367.0      | 38.0        |
| LMK01801BISQE/NOPB | WQFN         | RHS             | 48   | 250  | 210.0       | 185.0      | 35.0        |
| LMK01801BISQX/NOPB | WQFN         | RHS             | 48   | 2500 | 367.0       | 367.0      | 38.0        |

RHS0048A



DIMENSIONS ARE IN MILLIMETERS  
DIMENSIONS IN ( ) FOR REFERENCE ONLY

RECOMMENDED LAND PATTERN



SQA48A (Rev B)

## IMPORTANT NOTICE

Texas Instruments Incorporated and its subsidiaries (TI) reserve the right to make corrections, enhancements, improvements and other changes to its semiconductor products and services per JESD46, latest issue, and to discontinue any product or service per JESD48, latest issue. Buyers should obtain the latest relevant information before placing orders and should verify that such information is current and complete. All semiconductor products (also referred to herein as "components") are sold subject to TI's terms and conditions of sale supplied at the time of order acknowledgment.

TI warrants performance of its components to the specifications applicable at the time of sale, in accordance with the warranty in TI's terms and conditions of sale of semiconductor products. Testing and other quality control techniques are used to the extent TI deems necessary to support this warranty. Except where mandated by applicable law, testing of all parameters of each component is not necessarily performed.

TI assumes no liability for applications assistance or the design of Buyers' products. Buyers are responsible for their products and applications using TI components. To minimize the risks associated with Buyers' products and applications, Buyers should provide adequate design and operating safeguards.

TI does not warrant or represent that any license, either express or implied, is granted under any patent right, copyright, mask work right, or other intellectual property right relating to any combination, machine, or process in which TI components or services are used. Information published by TI regarding third-party products or services does not constitute a license to use such products or services or a warranty or endorsement thereof. Use of such information may require a license from a third party under the patents or other intellectual property of the third party, or a license from TI under the patents or other intellectual property of TI.

Reproduction of significant portions of TI information in TI data books or data sheets is permissible only if reproduction is without alteration and is accompanied by all associated warranties, conditions, limitations, and notices. TI is not responsible or liable for such altered documentation. Information of third parties may be subject to additional restrictions.

Resale of TI components or services with statements different from or beyond the parameters stated by TI for that component or service voids all express and any implied warranties for the associated TI component or service and is an unfair and deceptive business practice. TI is not responsible or liable for any such statements.

Buyer acknowledges and agrees that it is solely responsible for compliance with all legal, regulatory and safety-related requirements concerning its products, and any use of TI components in its applications, notwithstanding any applications-related information or support that may be provided by TI. Buyer represents and agrees that it has all the necessary expertise to create and implement safeguards which anticipate dangerous consequences of failures, monitor failures and their consequences, lessen the likelihood of failures that might cause harm and take appropriate remedial actions. Buyer will fully indemnify TI and its representatives against any damages arising out of the use of any TI components in safety-critical applications.

In some cases, TI components may be promoted specifically to facilitate safety-related applications. With such components, TI's goal is to help enable customers to design and create their own end-product solutions that meet applicable functional safety standards and requirements. Nonetheless, such components are subject to these terms.

No TI components are authorized for use in FDA Class III (or similar life-critical medical equipment) unless authorized officers of the parties have executed a special agreement specifically governing such use.

Only those TI components which TI has specifically designated as military grade or "enhanced plastic" are designed and intended for use in military/aerospace applications or environments. Buyer acknowledges and agrees that any military or aerospace use of TI components which have **not** been so designated is solely at the Buyer's risk, and that Buyer is solely responsible for compliance with all legal and regulatory requirements in connection with such use.

TI has specifically designated certain components as meeting ISO/TS16949 requirements, mainly for automotive use. In any case of use of non-designated products, TI will not be responsible for any failure to meet ISO/TS16949.

### Products

|                              |  |
|------------------------------|--|
| Audio                        | <a href="http://www.ti.com/audio">www.ti.com/audio</a>                               |
| Amplifiers                   | <a href="http://amplifier.ti.com">amplifier.ti.com</a>                               |
| Data Converters              | <a href="http://dataconverter.ti.com">dataconverter.ti.com</a>                       |
| DLP® Products                | <a href="http://www.dlp.com">www.dlp.com</a>   |
| DSP                          | <a href="http://dsp.ti.com">dsp.ti.com</a>   |
| Clocks and Timers            | <a href="http://www.ti.com/clocks">www.ti.com/clocks</a>                             |
| Interface                    | <a href="http://interface.ti.com">interface.ti.com</a>                               |
| Logic                        | <a href="http://logic.ti.com">logic.ti.com</a>                                       |
| Power Mgmt                   | <a href="http://power.ti.com">power.ti.com</a>                                       |
| Microcontrollers             | <a href="http://microcontroller.ti.com">microcontroller.ti.com</a>                   |
| RFID                         | <a href="http://www.ti-rfid.com">www.ti-rfid.com</a>                                 |
| OMAP Applications Processors | <a href="http://www.ti.com/omap">www.ti.com/omap</a>                                 |
| Wireless Connectivity        | <a href="http://www.ti.com/wirelessconnectivity">www.ti.com/wirelessconnectivity</a> |

### Applications

|                               |  |
|-------------------------------|--|
| Automotive and Transportation | <a href="http://www.ti.com/automotive">www.ti.com/automotive</a>                         |
| Communications and Telecom    | <a href="http://www.ti.com/communications">www.ti.com/communications</a>                 |
| Computers and Peripherals     | <a href="http://www.ti.com/computers">www.ti.com/computers</a>                           |
| Consumer Electronics          | <a href="http://www.ti.com/consumer-apps">www.ti.com/consumer-apps</a>                   |
| Energy and Lighting           | <a href="http://www.ti.com/energy">www.ti.com/energy</a>                                 |
| Industrial                    | <a href="http://www.ti.com/industrial">www.ti.com/industrial</a>                         |
| Medical                       | <a href="http://www.ti.com/medical">www.ti.com/medical</a>                               |
| Security                      | <a href="http://www.ti.com/security">www.ti.com/security</a>                             |
| Space, Avionics and Defense   | <a href="http://www.ti.com/space-avionics-defense">www.ti.com/space-avionics-defense</a> |
| Video and Imaging             | <a href="http://www.ti.com/video">www.ti.com/video</a>                                   |

### TI E2E Community

[e2e.ti.com](http://e2e.ti.com)