

RoHS

Parts Drawing

REVISIONS				
SYM	ECN No.	MODIFICATION	DATE	ISSUED

Note:

1.Material:

1.1,Housing: BLACK g.f,UL94v-0

1.2,Contact: copper alloy,t=0.25mm

1.3,Shell: copper/Ferroalloy alloy,t=0.30mm

2.Specification:

2.1,Current rating:5.0A Max.

2.2,Dielectric withstanding

voltage: 100 V(ac) for 1 min.

2.3,Contact resistance: 30 mΩ Max.

2.4,Insulation resistance: 100 MΩ Min.

2.5,Total mating force: 3.57 Kgf Max.

2.6,Total unmating force: 1.0 Kgf Min.

3.Finish:

3.1,Contact: Plated Golg in Mating Area:

Tin On Solder Talls

Shell: Nickel Plating

4.Environmental:

4.1,Temperature range: -55°C~85°C

PART ON:

907-222AXXX1Y1XX

电镀规格: 02, 镀金1u" 04, 镀金3u" 07, 镀金15u" 08, 镀金30u"

端子材质: 1, 青铜 2, 磷铜

端子规格: D, 90度 Y, 180度 S, SMT贴板

塑胶形态: 1, 双层短体 2, 双层半包

塑胶颜色: 01, 白色 02, 黑色 03, 本色

塑胶材质: 1, PBT 2, LCP 3, PA6T 4, PPA 5, PA6T

对接方向: A, 正向 B, 反向

外壳材质: 1, 铁壳 2, 铜壳

插口类型: 1, 有边平弹 2, 无边平弹

外壳脚型: 1, 弯脚 2, 直脚 3, 无脚

类别: 双层系列

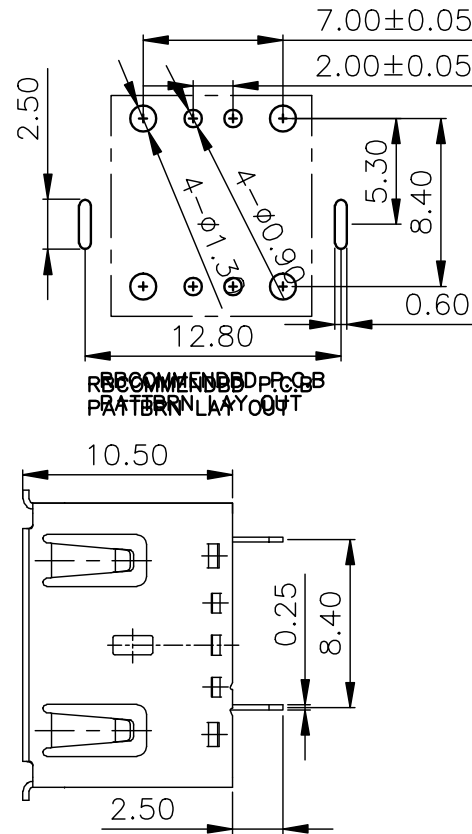
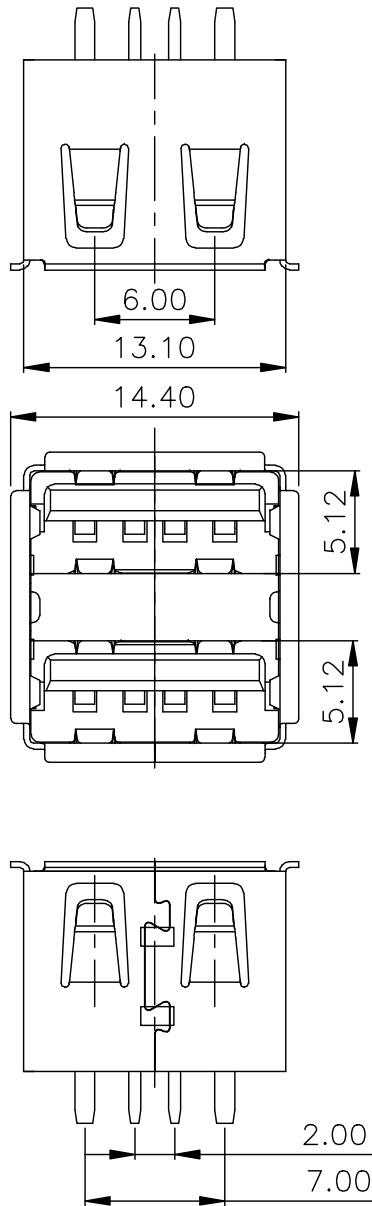

DRAWN	JU 深圳市精拓金电子有限公司			
CHECKED	TITLE	PART NO. SEE PART ON		
APPROVED	USB AF 10.5短体双层无脚有边	DRAWING NO. R907312A1021Y102		
	UNIT mm	TOLERANCE .XXX±10, .XX±25, .X±38, ANG±15°	SCALE 1:1	SHEET 1 OF 1
			SIZE A4	REV. X1