

LM27222 High-Speed 4.5A Synchronous MOSFET Driver

Check for Samples: [LM27222](#)

FEATURES

- Adaptive Shoot-through Protection
- 10ns Dead Time
- 8ns Propagation Delay
- 30ns Minimum On-time
- 0.4Ω Pull-down and 0.9Ω Pull-up Drivers
- 4.5A Peak Driving Current
- MOSFET Tolerant Design
- 5μA Quiescent Current
- 30V Maximum Input Voltage in Buck Configuration
- 4V to 6.85V Operating Voltage
- SOIC-8 and WSON Packages

APPLICATIONS

- High Current Buck And Boost Voltage Converters
- Fast Transient DC/DC Power Supplies
- Single Ended Forward Output Rectification
- CPU And GPU Core Voltage Regulators

DESCRIPTION

The LM27222 is a dual N-channel MOSFET driver designed to drive MOSFETs in push-pull configurations as typically used in synchronous buck regulators. The LM27222 takes the PWM output from a controller and provides the proper timing and drive levels to the power stage MOSFETs. Adaptive shoot-through protection prevents damaging and efficiency reducing shoot-through currents, thus ensuring a robust design capable of being used with nearly any MOSFET. The adaptive shoot-through protection circuitry also reduces the dead time down to as low as 10ns, ensuring the highest operating efficiency. The peak sourcing and sinking current for each driver of the LM27222 is about 3A and 4.5Amps respectively with a V_{gs} of 5V. System performance is also enhanced by keeping propagation delays down to 8ns. Efficiency is once again improved at all load currents by supporting synchronous, non-synchronous, and diode emulation modes through the LEN pin. The minimum output pulse width realized at the output of the MOSFETs is as low as 30ns. This enables high operating frequencies at very high conversion ratios in buck regulator designs. To support low power states in notebook systems, the LM27222 draws only 5μA from the 5V rail when the IN and LEN inputs are low or floating.

Typical Application

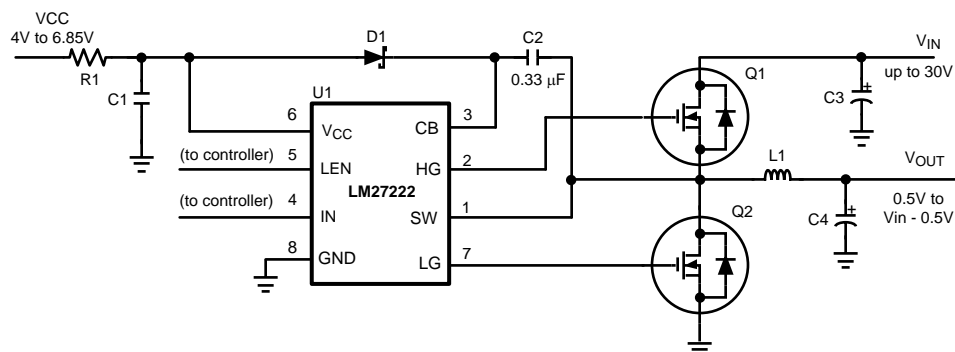

Please be aware that an important notice concerning availability, standard warranty, and use in critical applications of Texas Instruments semiconductor products and disclaimers thereto appears at the end of this data sheet.

All trademarks are the property of their respective owners.

Connection Diagram

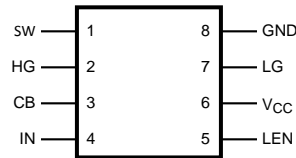
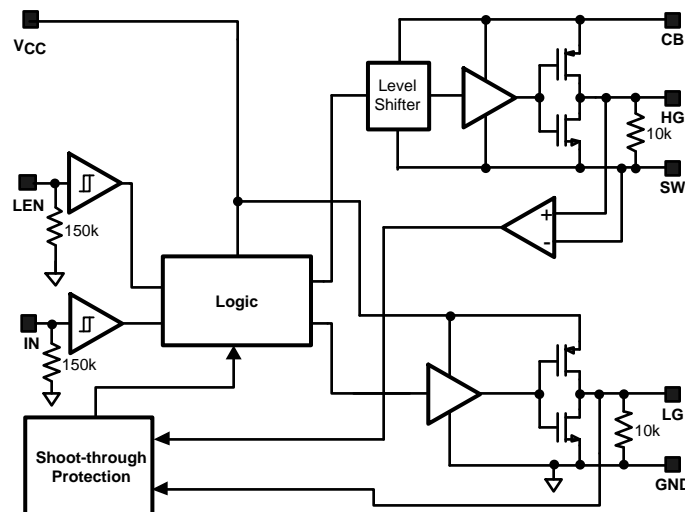

Figure 1. Top View
SOIC-8 (Package # D0008A) $\theta_{JA} = 172^{\circ}\text{C/W}$
or
WSO-8 (Package # NGT0008A) $\theta_{JA} = 39^{\circ}\text{C/W}$

PIN DESCRIPTIONS

Pin #	Pin Name	Pin Function
1	SW	High-side driver return. Should be connected to the common node of high and low-side MOSFETs.
2	HG	High-side gate drive output. Should be connected to the high-side MOSFET gate. Pulled down internally to SW with a 10K resistor to prevent spurious turn on of the high-side MOSFET when the driver is off.
3	CB	Bootstrap. Accepts a bootstrap voltage for powering the high-side driver.
4	IN	Accepts a PWM signal from a controller. Active High. Pulled down internally to GND with a 150K resistor to prevent spurious turn on of the high-side MOSFET when the controller is inactive.
5	LEN	Low-side gate enable. Active High. Pulled down internally to GND with a 150K resistor to prevent spurious turn-on of the low-side MOSFET when the controller is inactive.
6	V _{CC}	Connect to +5V supply.
7	LG	Low-side gate drive output. Should be connected to low-side MOSFET gate. Pulled down internally to GND with a 10K resistor to prevent spurious turn on of the low-side MOSFET when the driver is off.
8	GND	Ground.

Block Diagram



These devices have limited built-in ESD protection. The leads should be shorted together or the device placed in conductive foam during storage or handling to prevent electrostatic damage to the MOS gates.

Absolute Maximum Ratings ⁽¹⁾

V _{CC} to GND	-0.3V to 7V
CB to GND	-0.3V to 36V
CB to SW	-0.3V to 7V
SW to GND ⁽²⁾	-2V to 36V
LEN, IN, LG to GND	-0.3V to V _{CC} + 0.3V ≤ 7V
HG to GND	-0.3V to 36V
Junction Temperature	+150°C
Power Dissipation ⁽³⁾	720mW
Storage Temperature	-65° to 150°C
ESD Susceptibility Human Body Model	2kV

- (1) **Absolute Maximum Ratings** are limits beyond which damage to the device may occur. **Operating ratings** are conditions under which the device operates correctly. Operating Ratings do not imply ensured performance limits.
- (2) The SW pin can have -2V to -0.5 volts applied for a maximum duty cycle of 10% with a maximum period of 1 second. There is no duty cycle or maximum period limitation for a SW pin voltage range of -0.5V to 30 Volts.
- (3) Maximum allowable power dissipation is a function of the maximum junction temperature, T_{JMAX}, the junction-to-ambient thermal resistance, θ_{JA}, and the ambient temperature, T_A. The maximum allowable power dissipation at any ambient temperature is calculated using: P_{MAX} = (T_{JMAX} - T_A) / θ_{JA}. The junction-to-ambient thermal resistance, θ_{JA}, for the LM27222M, it is 165°C/W. For a T_{JMAX} of 150°C and T_A of 25°C, the maximum allowable power dissipation is 0.76W. The θ_{JA} for the LM27222SD is 42°C/W. For a T_{JMAX} of 150°C and T_A of 25°C, the maximum allowable power dissipation is 3W.

Operating Ratings ⁽¹⁾

VCC	4V to 6.85V
Junction Temperature Range	-40° to 125°C
CB (max)	33V

- (1) **Absolute Maximum Ratings** are limits beyond which damage to the device may occur. **Operating ratings** are conditions under which the device operates correctly. Operating Ratings do not imply ensured performance limits.

Electrical Characteristics ⁽¹⁾

VCC = CB = 5V, SW = GND = 0V, unless otherwise specified. Typical and limits appearing in plain type apply for T_A = T_J = +25°C. Limits appearing in **boldface** type apply over the entire operating temperature range (-40°C ≤ T_J ≤ 125°C).

Symbol	Parameter	Conditions	Min	Typ	Max	Units
POWER SUPPLY						
I _{q_op}	Operating Quiescent Current	IN = 0V, LEN = 0V		5	15	μA
				30		
		IN = 0V, LEN = 5V	500	540	650	μA
					825	
HIGH-SIDE DRIVER						
	Peak Pull-up Current			3		A
R _{H-pu}	Pull-up Rds_on	I _{CB} = I _{HG} = 0.3A		0.9	2.5	Ω
	Peak Pull-down Current			4.5		A
R _{H-pd}	Pull-down Rds_on	I _{SW} = I _{HG} = 0.3A		0.4	1.5	Ω
t ₄	Rise Time	Timing Diagram, C _{LOAD} = 3.3nF		17		ns
t ₆	Fall Time	Timing Diagram, C _{LOAD} = 3.3nF		12		ns
t ₃	Pull-up Dead Time	Timing Diagram		9.5		ns
t ₅	Pull-down Delay	Timing Diagram		16.5		ns
t _{on_min}	Minimum Positive Output Pulse Width			30		ns
LOW-SIDE DRIVER						
	Peak Pull-up Current			3.2		A
R _{L-pu}	Pull-up Rds_on	I _{VCC} = I _{LG} = 0.3A		0.9	2.5	Ω
	Peak Pull-down Current			4.5		A
R _{L-pd}	Pull-down Rds_on	I _{GND} = I _{LG} = 0.3A		0.4	1.5	Ω
t ₈	Rise Time	Timing Diagram, C _{LOAD} = 3.3nF		17		ns
t ₂	Fall Time	Timing Diagram, C _{LOAD} = 3.3nF		14		ns
t ₇	Pull-up Dead Time	Timing Diagram		11.5		ns
t ₁	Pull-down Delay	Timing Diagram		7.7		ns
PULL-DOWN RESISTANCES						
	HG-SW Pull-down Resistance			10k		Ω
	LG-GND Pull-down Resistance			10k		Ω
	LEN-GND Pull-down Resistance			150K		Ω
	IN-GND Pull-down Resistance			150K		Ω
LEAKAGE CURRENTS						
I _{leak_IN}	IN pin Leakage Current	IN = 0V, Source Current		50		nA
		IN = 5V, Sink Current		33		μA
I _{leak_LEN}	LEN pin Leakage Current	LEN = 0V, Source Current		200		nA
		LEN = 5V, Sink Current		33		μA
LOGIC						
V _{IH_LEN}	LEN Low to High Threshold	Low to High Transition			65	% of V _{CC}
V _{IL_LEN}	LEN High to Low Threshold	High to Low Transition	30			% of V _{CC}
V _{IH_IN}	IN Low to High Threshold	Low to High Transition			65	% of V _{CC}
V _{IL_IN}	IN High to Low Threshold	High to Low Transition	30			% of V _{CC}
	Threshold Hysteresis			0.7		V

(1) Min and Max limits are 100% production tested at 25°C. Limits over the operating temperature range are ensured through correlation using Statistical Quality Control (SQC) methods. Limits are used to calculate Average Outgoing Quality Level (AOQL).

Timing Diagram

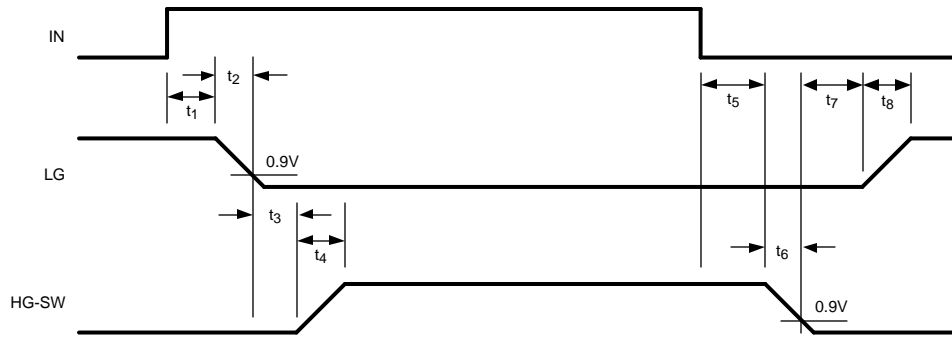

Typical Waveforms

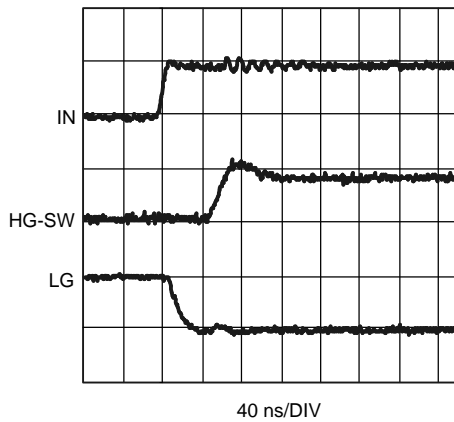

Figure 2. PWM Low-to-High Transition at IN Input

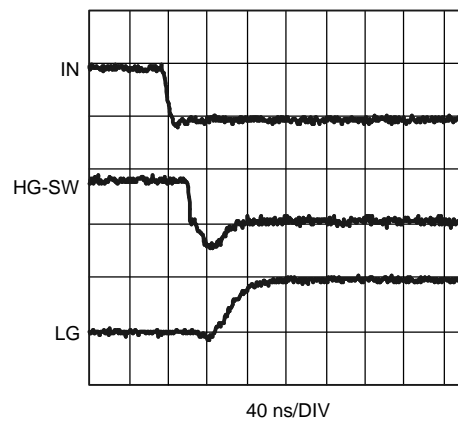

Figure 3. PWM High-to-Low Transition at IN Input

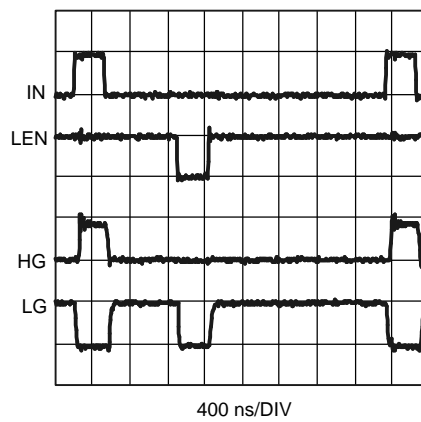

Figure 4. LEN Operation

The typical waveforms are from a circuit similar to [Typical Application](#) with:

Q1: 2 x Si7390DP

Q2: 2 x Si7356DP

L1: 0.4 μ H

V_{IN} : 12V

APPLICATION INFORMATION

GENERAL

The LM27222 is designed for high speed and high operating reliability. The driver can handle very narrow, down to zero, PWM pulses in a specified, deterministic way. Therefore, the HG and LG outputs are always in predictable states. No latches are used in the HG and LG control logic so the drivers cannot get "stuck" in the wrong state. The driver design allows for powering up with a pre-biasing voltage being present at the regulator output. To reduce conduction losses in DC-DC converters with low duty factors the LM27222 driver can be powered from a $6.5V \pm 5\%$ power rail.

It is recommended to use the same power rail for both the controller and driver. If two different power rails are used, never allow the PWM pulse magnitude at the IN input or the control voltage at the LEN input to be above the driver V_{CC} voltage or unpredictable HG and LG outputs pulse widths may result.

MINIMUM PULSE WIDTH

As the input pulse width to the IN pin is decreased, the pulse width of the high-side gate drive (HG-SW) also decreases. However, for input pulse widths 60ns and smaller, the HG-SW remains constant at 30ns. Thus the minimum pulse width of the driver output is 30ns. Figure 5 shows an input pulse at the IN pin 20ns wide, and the output of the driver, as measured between the nodes HG and SW is a 30ns wide pulse. Figure 6 shows the variation of the SW node pulse width vs IN pulse width. At the IN pin, if a falling edge is followed by a rising edge within 5ns, the HG may ignore the rising edge and remain low until the IN pin toggles again. If a rising edge is followed by a falling edge within 5ns, the pulse may be completely ignored.

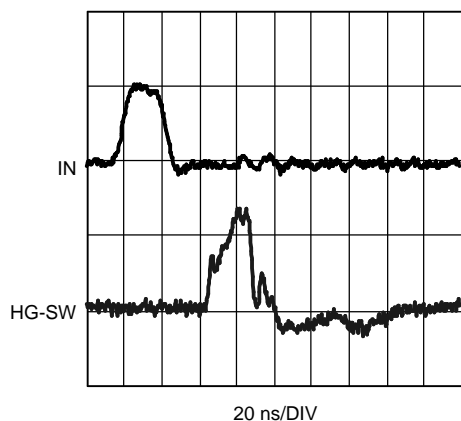

Figure 5. Min On Time

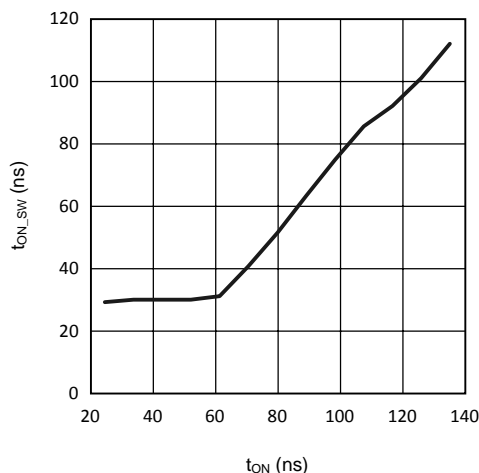

Figure 6.

ADAPTIVE SHOOT-THROUGH PROTECTION

The LM27222 prevents shoot-through power loss by ensuring that both the high- and low-side MOSFETs are not conducting at the same time. When the IN signal rises, LG is first pulled down. The adaptive shoot-through protection circuit waits for LG to reach 0.9V before turning on HG. Similarly, when IN goes low, HG is pulled down first, and the circuit turns LG on only after the voltage difference between the high-side gate and the switch node, i.e., HG-SW, has fallen to 0.9V.

It is possible in some applications that at power-up the driver's SW pin is above 3V in either buck or boost converter applications. For instance, in a buck configuration a pre-biasing voltage can be either a voltage from another power rail connected to the load, or a leakage voltage through the load, or it can be an output capacitor pre-charged above 3V while no significant load is present. In a boost application it can be an input voltage rail above 3V.

In the case of insufficient initial CB-SW voltage (less than 2V) such as when the output rail is pre-biased, the shoot-through protection circuit holds LG low for about 170ns, beginning from the instant when IN goes high. After the 170ns delay, the status of LG is dictated by LEN and IN. Once LG goes high and SW goes low, the bootstrap capacitor will be charged up (assuming SW is grounded for long enough time). As a result, CB-SW will be close to 5V and the LM27222 will now fully support synchronous operation.

The dead-time between the high- and low-side pulses is kept as small as possible to minimize conduction through the body diode of the low-side MOSFET(s).

POWER DISSIPATION

The power dissipated in the driver IC when switching synchronously can be calculated as follows:

$$P = \frac{f_{SW} \times V_{CC}}{2} \left\{ Q_{G-H} \left[\frac{R_{H-pu}}{R_{H-pu} + R_{G-H}} \right] + \left[\frac{R_{H-pd}}{R_{H-pd} + R_{G-H}} \right] \right. \\ \left. + Q_{G-L} \left[\frac{R_{L-pu}}{R_{L-pu} + R_{G-L}} \right] + \left[\frac{R_{L-pd}}{R_{L-pd} + R_{G-L}} \right] \right\}$$

where

- where f_{SW} = switching frequency
- V_{CC} = voltage at the V_{CC} pin
- Q_{G-H} = total gate charge of the (parallel combination of the) high-side MOSFET(s)
- Q_{G-L} = total gate charge of the (parallel combination of the) low-side MOSFET(s)
- R_{G-H} = gate resistance of the (parallel combination of the) high-side MOSFET(s)
- R_{G-L} = gate resistance of the (parallel combination of the) low-side MOSFET(S)
- R_{H-pu} = pull-up R_{DS_ON} of the high-side driver
- R_{H-pd} = pull-down R_{DS_ON} of the high-side driver
- R_{L-pu} = pull-up R_{DS_ON} of the low-side driver
- R_{L-pd} = pull-down R_{DS_ON} of the low-side driver

(1)

PC BOARD LAYOUT GUIDELINES

1. Place the driver as close to the MOSFETs as possible.
2. HG, SW, LG, GND: Run short, thick traces between the driver and the MOSFETs. To minimize parasitics, the traces for HG and SW should run parallel and close to each other. The same is true for LG and GND.
3. Driver V_{CC} : Place the decoupling capacitor close to the V_{CC} and GND pins.
4. The high-current loop between the high-side and low-side MOSFETs and the input capacitors should be as small as possible.
5. There should be enough copper area near the MOSFETs and the inductor for heat dissipation. Vias may also be added to carry the heat to other layers.

TYPICAL APPLICATION CIRCUIT DESCRIPTION

The Application Example on the following page shows the LM27222 being used with the LM27212, a 2-phase hysteretic current mode controller. Although this circuit is capable of operating from 5V to 28V, the components are optimized for an input voltage range of 9V to 28V. The high-side FET is selected for low gate charge to reduce switching losses. For low duty cycles, the average current through the high-side FET is relatively small and thus we trade off higher conduction losses for lower switching losses. The low-side FET is selected solely on R_{DS_ON} to minimize conduction losses. If the input voltage range were 4V to 6V, the MOSFET selection should be changed. First, much lower voltage FETs can be used, and secondly, high-side FET R_{DS_ON} becomes a larger loss factor than the switching losses. Of course with a lower input voltage, the input capacitor voltage rating can be reduced and the inductor value can be reduced as well. For a 4V to 6V application, the inductor can be reduced to 200nH to 300nH. The switching frequency of the LM27212 is determined by the allowed ripple current in the inductor. This circuit is set for approximately 300kHz. At lower input voltages, higher frequencies are possible without suffering a significant efficiency loss. Although the LM27222 can support operating frequencies up to 2MHz in many applications, the LM27212 should be limited to about 1MHz. The control architecture of the LM27212 and the low propagation times of the LM27222 potentially gives this solution the fastest transient response in the industry.

Application Example

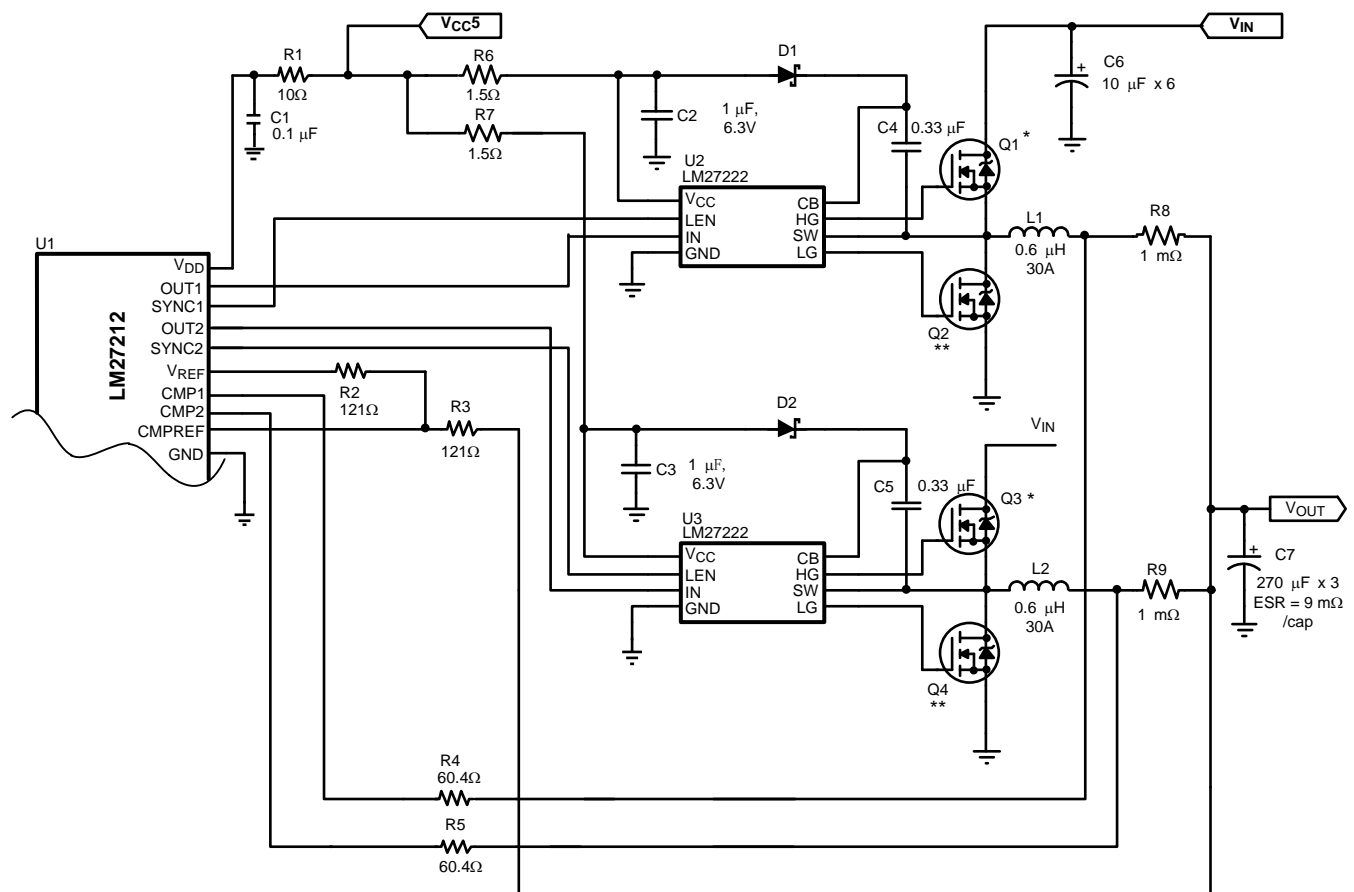

* Q1, Q3: 2 x Si7390DP

** Q2, Q4: 2 x Si7356DP

REVISION HISTORY

Changes from Revision A (March 2013) to Revision B	Page
<hr/> <ul style="list-style-type: none">• Changed layout of National Data Sheet to TI format <hr/>	<hr/> 8 <hr/>

PACKAGING INFORMATION

Orderable Device	Status (1)	Package Type	Package Drawing	Pins	Package Qty	Eco Plan (2)	Lead/Ball Finish (6)	MSL Peak Temp (3)	Op Temp (°C)	Device Marking (4/5)	Samples
LM27222M	NRND	SOIC	D	8	95	TBD	Call TI	Call TI	-40 to 125	27222 M	
LM27222M/NOPB	ACTIVE	SOIC	D	8	95	Green (RoHS & no Sb/Br)	SN	Level-1-260C-UNLIM	-40 to 125	27222 M	Samples
LM27222MX/NOPB	ACTIVE	SOIC	D	8	2500	Green (RoHS & no Sb/Br)	SN	Level-1-260C-UNLIM	-40 to 125	27222 M	Samples
LM27222SD/NOPB	ACTIVE	WSO8	NGT	8	1000	Green (RoHS & no Sb/Br)	SN	Level-1-260C-UNLIM	-40 to 125	L27222S	Samples

(1) The marketing status values are defined as follows:

ACTIVE: Product device recommended for new designs.

LIFEBUY: TI has announced that the device will be discontinued, and a lifetime-buy period is in effect.

NRND: Not recommended for new designs. Device is in production to support existing customers, but TI does not recommend using this part in a new design.

PREVIEW: Device has been announced but is not in production. Samples may or may not be available.

OBSELETE: TI has discontinued the production of the device.

(2) **RoHS:** TI defines "RoHS" to mean semiconductor products that are compliant with the current EU RoHS requirements for all 10 RoHS substances, including the requirement that RoHS substance do not exceed 0.1% by weight in homogeneous materials. Where designed to be soldered at high temperatures, "RoHS" products are suitable for use in specified lead-free processes. TI may reference these types of products as "Pb-Free".

RoHS Exempt: TI defines "RoHS Exempt" to mean products that contain lead but are compliant with EU RoHS pursuant to a specific EU RoHS exemption.

Green: TI defines "Green" to mean the content of Chlorine (Cl) and Bromine (Br) based flame retardants meet JS709B low halogen requirements of <=1000ppm threshold. Antimony trioxide based flame retardants must also meet the <=1000ppm threshold requirement.

(3) MSL, Peak Temp. - The Moisture Sensitivity Level rating according to the JEDEC industry standard classifications, and peak solder temperature.

(4) There may be additional marking, which relates to the logo, the lot trace code information, or the environmental category on the device.

(5) Multiple Device Markings will be inside parentheses. Only one Device Marking contained in parentheses and separated by a "-" will appear on a device. If a line is indented then it is a continuation of the previous line and the two combined represent the entire Device Marking for that device.

(6) Lead/Ball Finish - Orderable Devices may have multiple material finish options. Finish options are separated by a vertical ruled line. Lead/Ball Finish values may wrap to two lines if the finish value exceeds the maximum column width.

Important Information and Disclaimer:The information provided on this page represents TI's knowledge and belief as of the date that it is provided. TI bases its knowledge and belief on information provided by third parties, and makes no representation or warranty as to the accuracy of such information. Efforts are underway to better integrate information from third parties. TI has taken and

continues to take reasonable steps to provide representative and accurate information but may not have conducted destructive testing or chemical analysis on incoming materials and chemicals. TI and TI suppliers consider certain information to be proprietary, and thus CAS numbers and other limited information may not be available for release.

In no event shall TI's liability arising out of such information exceed the total purchase price of the TI part(s) at issue in this document sold by TI to Customer on an annual basis.

TAPE AND REEL INFORMATION



QUADRANT ASSIGNMENTS FOR PIN 1 ORIENTATION IN TAPE



*All dimensions are nominal

Device	Package Type	Package Drawing	Pins	SPQ	Reel Diameter (mm)	Reel Width W1 (mm)	A0 (mm)	B0 (mm)	K0 (mm)	P1 (mm)	W (mm)	Pin1 Quadrant
LM27222MX/NOPB	SOIC	D	8	2500	330.0	12.4	6.5	5.4	2.0	8.0	12.0	Q1
LM27222SD/NOPB	WSO	NGT	8	1000	178.0	12.4	4.3	4.3	1.3	8.0	12.0	Q1

TAPE AND REEL BOX DIMENSIONS



*All dimensions are nominal

Device	Package Type	Package Drawing	Pins	SPQ	Length (mm)	Width (mm)	Height (mm)
LM27222MX/NOPB	SOIC	D	8	2500	367.0	367.0	35.0
LM27222SD/NOPB	WSON	NGT	8	1000	210.0	185.0	35.0

EXAMPLE BOARD LAYOUT

NGT0008A

WSON - 0.8 mm max height

PLASTIC SMALL OUTLINE - NO LEAD

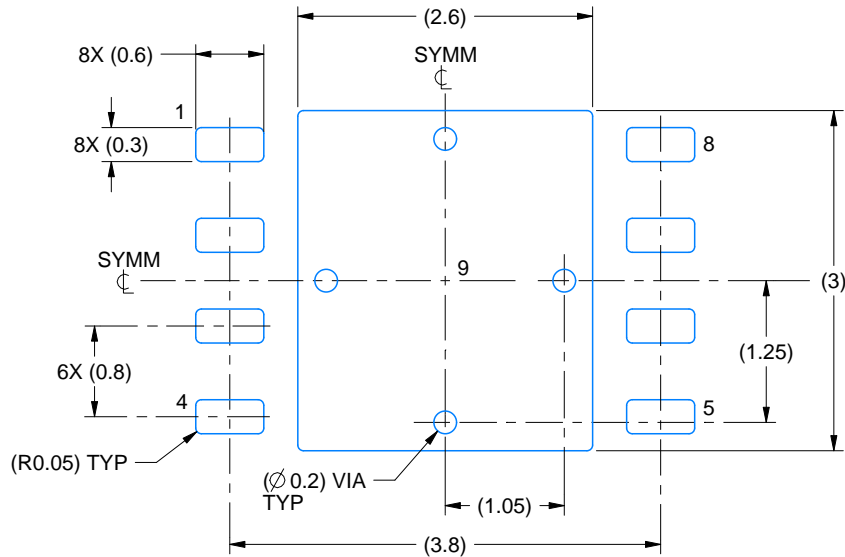

LAND PATTERN EXAMPLE
EXPOSED METAL SHOWN
SCALE:15X

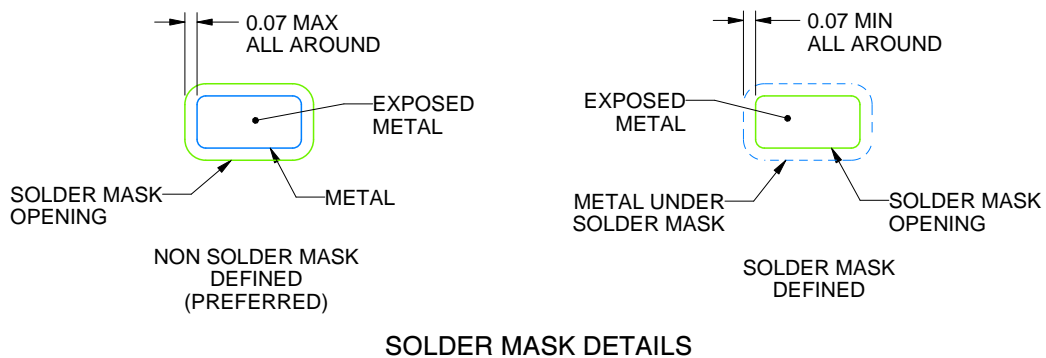

SOLDER MASK DETAILS

4214935/A 08/2020

NOTES: (continued)

4. This package is designed to be soldered to a thermal pad on the board. For more information, see Texas Instruments literature number SLUA271 (www.ti.com/lit/sluea271).
5. Vias are optional depending on application, refer to device data sheet. If any vias are implemented, refer to their locations shown on this view. It is recommended that vias under paste be filled, plugged or tented.

EXAMPLE STENCIL DESIGN

NGT0008A

WSON - 0.8 mm max height

PLASTIC SMALL OUTLINE - NO LEAD

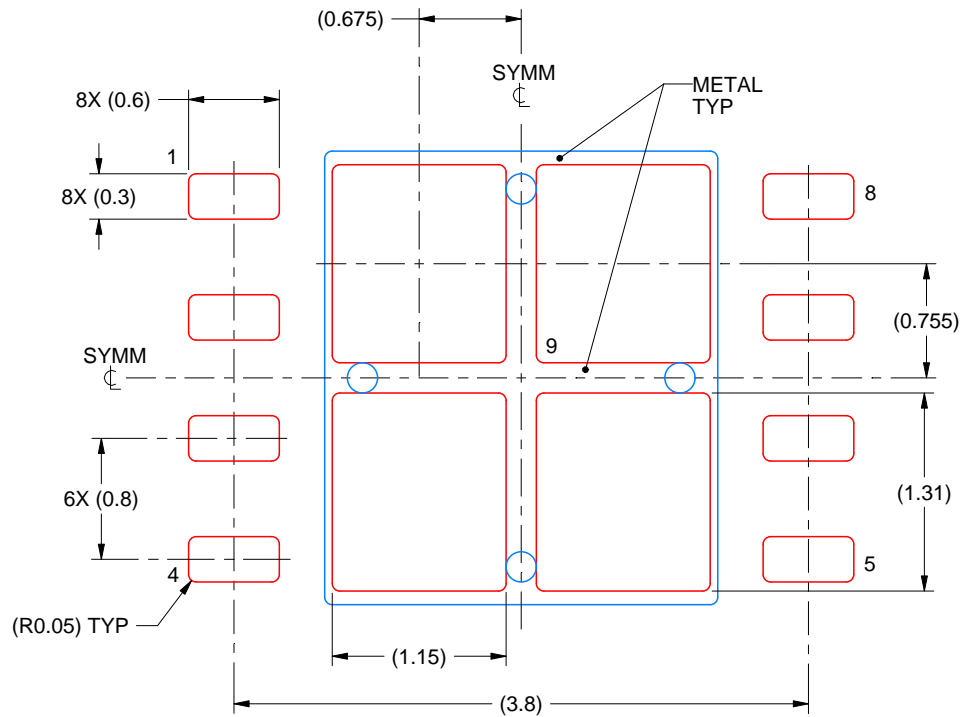

SOLDER PASTE EXAMPLE
BASED ON 0.125 mm THICK STENCIL

EXPOSED PAD 9:
77% PRINTED SOLDER COVERAGE BY AREA UNDER PACKAGE
SCALE:20X

4214935/A 08/2020

NOTES: (continued)

6. Laser cutting apertures with trapezoidal walls and rounded corners may offer better paste release. IPC-7525 may have alternate design recommendations.



D0008A

PACKAGE OUTLINE

SOIC - 1.75 mm max height

SMALL OUTLINE INTEGRATED CIRCUIT



4214825/C 02/2019

NOTES:

1. Linear dimensions are in inches [millimeters]. Dimensions in parenthesis are for reference only. Controlling dimensions are in inches. Dimensioning and tolerancing per ASME Y14.5M.
2. This drawing is subject to change without notice.
3. This dimension does not include mold flash, protrusions, or gate burrs. Mold flash, protrusions, or gate burrs shall not exceed .006 [0.15] per side.
4. This dimension does not include interlead flash.
5. Reference JEDEC registration MS-012, variation AA.

EXAMPLE BOARD LAYOUT

D0008A

SOIC - 1.75 mm max height

SMALL OUTLINE INTEGRATED CIRCUIT



LAND PATTERN EXAMPLE
EXPOSED METAL SHOWN
SCALE:8X



SOLDER MASK DETAILS

4214825/C 02/2019

NOTES: (continued)

6. Publication IPC-7351 may have alternate designs.

7. Solder mask tolerances between and around signal pads can vary based on board fabrication site.

EXAMPLE STENCIL DESIGN

D0008A

SOIC - 1.75 mm max height

SMALL OUTLINE INTEGRATED CIRCUIT



SOLDER PASTE EXAMPLE
BASED ON .005 INCH [0.125 MM] THICK STENCIL
SCALE:8X

4214825/C 02/2019

NOTES: (continued)

8. Laser cutting apertures with trapezoidal walls and rounded corners may offer better paste release. IPC-7525 may have alternate design recommendations.
9. Board assembly site may have different recommendations for stencil design.

IMPORTANT NOTICE AND DISCLAIMER

TI PROVIDES TECHNICAL AND RELIABILITY DATA (INCLUDING DATASHEETS), DESIGN RESOURCES (INCLUDING REFERENCE DESIGNS), APPLICATION OR OTHER DESIGN ADVICE, WEB TOOLS, SAFETY INFORMATION, AND OTHER RESOURCES "AS IS" AND WITH ALL FAULTS, AND DISCLAIMS ALL WARRANTIES, EXPRESS AND IMPLIED, INCLUDING WITHOUT LIMITATION ANY IMPLIED WARRANTIES OF MERCHANTABILITY, FITNESS FOR A PARTICULAR PURPOSE OR NON-INFRINGEMENT OF THIRD PARTY INTELLECTUAL PROPERTY RIGHTS.

These resources are intended for skilled developers designing with TI products. You are solely responsible for (1) selecting the appropriate TI products for your application, (2) designing, validating and testing your application, and (3) ensuring your application meets applicable standards, and any other safety, security, or other requirements. These resources are subject to change without notice. TI grants you permission to use these resources only for development of an application that uses the TI products described in the resource. Other reproduction and display of these resources is prohibited. No license is granted to any other TI intellectual property right or to any third party intellectual property right. TI disclaims responsibility for, and you will fully indemnify TI and its representatives against, any claims, damages, costs, losses, and liabilities arising out of your use of these resources.

TI's products are provided subject to TI's Terms of Sale (www.ti.com/legal/termsofsale.html) or other applicable terms available either on ti.com or provided in conjunction with such TI products. TI's provision of these resources does not expand or otherwise alter TI's applicable warranties or warranty disclaimers for TI products.

Mailing Address: Texas Instruments, Post Office Box 655303, Dallas, Texas 75265
Copyright © 2020, Texas Instruments Incorporated