

# ALUMINUM ELECTROLYTIC CAPACITORS

# LLS

Snap-in Terminal Type, 85°C Standard



Anti-Solvent  
Feature  
(Through  
100V only)

- Withstanding 3000 hours application of rated ripple current at 85°C.
- Compliant to the RoHS directive (2011/65/EU, (EU)2015/863).

**LLS**



**LLG**

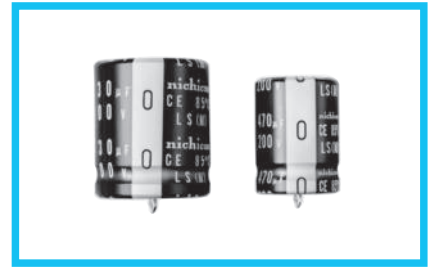

## Specifications

Item	Performance Characteristics																													
Category Temperature Range	- 40 to +85°C (16 to 250V), - 25 to +85°C (350 to 450V)																													
Rated Voltage Range	16 to 450V																													
Rated Capacitance Range	56 to 56000μF																													
Capacitance Tolerance	± 20% at 120Hz, 20°C																													
Leakage Current	$I \leq 3\sqrt{CV}$ (μA) (After 5 minutes' application of rated voltage) [C : Rated Capacitance (μF) V : Voltage (V)]																													
Tangent of loss angle (tan δ)	Measurement frequency : 120Hz at 20°C																													
	<table border="1"> <tr> <th>Rated voltage (V)</th> <th>16</th> <th>25</th> <th>35</th> <th>50</th> <th>63</th> <th>80</th> <th>100</th> <th>160</th> <th>180</th> <th>200</th> <th>250</th> <th>350</th> <th>400</th> <th>450</th> </tr> <tr> <td>tan δ (MAX.)</td> <td>0.50</td> <td>0.40</td> <td>0.35</td> <td>0.30</td> <td>0.25</td> <td>0.20</td> <td>0.20</td> <td>0.15</td> <td>0.15</td> <td>0.15</td> <td>0.15</td> <td>0.15</td> <td>0.15</td> <td>0.20</td> </tr> </table>	Rated voltage (V)	16	25	35	50	63	80	100	160	180	200	250	350	400	450	tan δ (MAX.)	0.50	0.40	0.35	0.30	0.25	0.20	0.20	0.15	0.15	0.15	0.15	0.15	0.15
Rated voltage (V)	16	25	35	50	63	80	100	160	180	200	250	350	400	450																
tan δ (MAX.)	0.50	0.40	0.35	0.30	0.25	0.20	0.20	0.15	0.15	0.15	0.15	0.15	0.15	0.20																
Stability at Low Temperature	Measurement frequency : 120Hz																													
	<table border="1"> <tr> <th colspan="2">Rated voltage (V)</th> <th>16 to 100</th> <th>160 to 250</th> <th>350 to 450</th> </tr> <tr> <td rowspan="2">Impedance ratio ZT/Z20(MAX.)</td> <td>Z - 25°C/Z+20°C</td> <td>4</td> <td>3</td> <td>8</td> </tr> <tr> <td>Z - 40°C/Z+20°C</td> <td>20</td> <td>12</td> <td>—</td> </tr> </table>	Rated voltage (V)		16 to 100	160 to 250	350 to 450	Impedance ratio ZT/Z20(MAX.)	Z - 25°C/Z+20°C	4	3	8	Z - 40°C/Z+20°C	20	12	—															
Rated voltage (V)		16 to 100	160 to 250	350 to 450																										
Impedance ratio ZT/Z20(MAX.)	Z - 25°C/Z+20°C	4	3	8																										
	Z - 40°C/Z+20°C	20	12	—																										
Endurance	The specifications listed at right shall be met when the capacitors are restored to 20°C after D.C. bias plus rated ripple current is applied for 3000 hours at 85°C, the peak voltage shall not exceed the rated voltage.																													
		<table border="1"> <tr> <td>Capacitance change</td> <td>Within ±20% of the initial capacitance value</td> </tr> <tr> <td>tan δ</td> <td>200% or less than the initial specified value</td> </tr> <tr> <td>Leakage current</td> <td>Less than or equal to the initial specified value</td> </tr> </table>	Capacitance change	Within ±20% of the initial capacitance value	tan δ	200% or less than the initial specified value	Leakage current	Less than or equal to the initial specified value																						
Capacitance change	Within ±20% of the initial capacitance value																													
tan δ	200% or less than the initial specified value																													
Leakage current	Less than or equal to the initial specified value																													
Shelf Life	After storing the capacitors under no load at 85°C for 1000 hours and then performing voltage treatment based on JIS C 5101-4 clause 4.1 at 20°C, they shall meet the requirements listed at right.																													
		<table border="1"> <tr> <td>Capacitance change</td> <td>Within ±15% of the initial capacitance value</td> </tr> <tr> <td>tan δ</td> <td>150% or less than the initial specified value</td> </tr> <tr> <td>Leakage current</td> <td>Less than or equal to the initial specified value</td> </tr> </table>	Capacitance change	Within ±15% of the initial capacitance value	tan δ	150% or less than the initial specified value	Leakage current	Less than or equal to the initial specified value																						
Capacitance change	Within ±15% of the initial capacitance value																													
tan δ	150% or less than the initial specified value																													
Leakage current	Less than or equal to the initial specified value																													
Marking	Printed with white color letter on black sleeve.																													

## Drawing

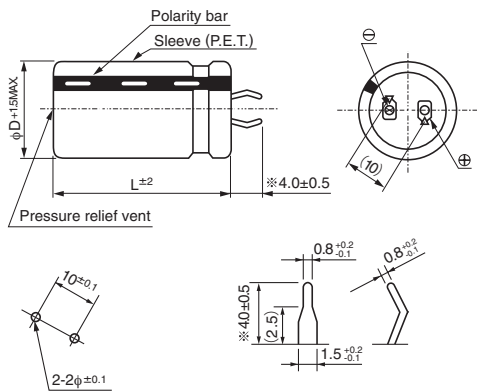

(PC board hole dimensions)

(Terminal dimensions)

\* Other terminations available upon request.  
Please refer to the Guidelines for Aluminum Electrolytic Capacitors.

## Type numbering system ( Example : 200V 390μF)

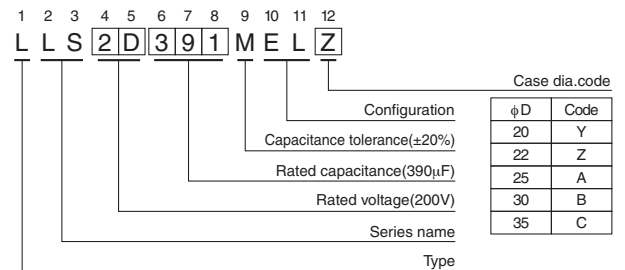

## Frequency coefficient of rated ripple current

Frequency (Hz)	50	60	120	300	1 k	10k	50k or more
Coeff.	16 to 100V	0.88	0.90	1.00	1.07	1.15	1.15
	160 to 250V	0.81	0.85	1.00	1.17	1.32	1.45
	350 to 450V	0.77	0.82	1.00	1.16	1.30	1.41

Minimum order quantity : 50pcs.

● Dimension table in next page.



## ■ Dimensions

16V (1C)				
Cap. (μF)	Size φD × L(mm)	Rated ripple (mArms)	Leakage Current (mA)	Code
8200	22 × 25	2560	1.08	LLS1C822MELZ
10000	22 × 30	2890	1.20	LLS1C103MELZ
12000	22 × 30	3130	1.31	LLS1C123MELZ
	25 × 25	3010	1.31	LLS1C123MELA
15000	22 × 35	3690	1.46	LLS1C153MELZ
	25 × 30	3640	1.46	LLS1C153MELA
	30 × 25	3730	1.46	LLS1C153MELB
18000	22 × 40	3980	1.60	LLS1C183MELZ
	25 × 35	3980	1.60	LLS1C183MELA
	30 × 30	3880	1.60	LLS1C183MELB
22000	22 × 50	4520	1.77	LLS1C223MELZ
	25 × 40	4440	1.77	LLS1C223MELA
	30 × 30	4380	1.77	LLS1C223MELB
27000	25 × 45	4980	1.97	LLS1C273MELA
	30 × 35	4950	1.97	LLS1C273MELB
	35 × 30	4820	1.97	LLS1C273MELC
33000	25 × 50	5490	2.17	LLS1C333MELA
	30 × 40	5600	2.17	LLS1C333MELB
	35 × 30	5460	2.17	LLS1C333MELC
39000	30 × 45	6210	2.36	LLS1C393MELB
	35 × 35	6120	2.36	LLS1C393MELC
47000	30 × 50	6930	2.60	LLS1C473MELB
	35 × 40	6890	2.60	LLS1C473MELC
56000	35 × 45	7690	2.83	LLS1C563MELC

25V (1E)				
Cap. (μF)	Size φD × L(mm)	Rated ripple (mArms)	Leakage Current (mA)	Code
5600	22 × 25	2310	1.12	LLS1E562MELZ
6800	22 × 30	2560	1.23	LLS1E682MELZ
	25 × 25	2470	1.23	LLS1E682MELA
8200	22 × 35	2860	1.35	LLS1E822MELZ
	25 × 25	2780	1.35	LLS1E822MELA
10000	22 × 35	3310	1.50	LLS1E103MELZ
	25 × 30	3160	1.50	LLS1E103MELA
12000	22 × 40	3770	1.64	LLS1E123MELZ
	25 × 35	3630	1.64	LLS1E123MELA
	30 × 25	3800	1.64	LLS1E123MELB
15000	22 × 50	4210	1.83	LLS1E153MELZ
	25 × 40	4100	1.83	LLS1E153MELA
	30 × 30	4000	1.83	LLS1E153MELB
18000	25 × 45	4680	2.01	LLS1E183MELA
	30 × 35	4660	2.01	LLS1E183MELB
	35 × 30	4680	2.01	LLS1E183MELC
22000	25 × 50	5190	2.22	LLS1E223MELA
	30 × 40	5330	2.22	LLS1E223MELB
	35 × 35	5260	2.22	LLS1E223MELC
27000	30 × 45	6020	2.46	LLS1E273MELB
	35 × 40	6020	2.46	LLS1E273MELC
33000	35 × 45	6750	2.72	LLS1E333MELC
39000	35 × 50	7560	2.96	LLS1E393MELC

35V (1V)				
Cap. (μF)	Size φD × L(mm)	Rated ripple (mArms)	Leakage Current (mA)	Code
3900	22 × 25	2220	1.10	LLS1V392MELZ
4700	22 × 30	2460	1.21	LLS1V472MELZ
	25 × 25	2430	1.21	LLS1V472MELA
5600	22 × 35	2790	1.32	LLS1V562MELZ
	25 × 30	2750	1.32	LLS1V562MELA
6800	22 × 40	2970	1.46	LLS1V682MELZ
	25 × 30	2890	1.46	LLS1V682MELA
	30 × 25	3090	1.46	LLS1V682MELB
8200	22 × 45	3470	1.60	LLS1V822MELZ
	25 × 35	3330	1.60	LLS1V822MELA
	30 × 30	3290	1.60	LLS1V822MELB
10000	22 × 50	3750	1.77	LLS1V103MELZ
	25 × 40	3650	1.77	LLS1V103MELA
	30 × 30	3610	1.77	LLS1V103MELB
12000	25 × 45	4150	1.94	LLS1V123MELA
	30 × 35	4140	1.94	LLS1V123MELB
	35 × 30	4270	1.94	LLS1V123MELC
15000	25 × 50	4800	2.17	LLS1V153MELA
	30 × 40	4800	2.17	LLS1V153MELB
	35 × 35	4950	2.17	LLS1V153MELC
18000	30 × 45	5300	2.38	LLS1V183MELB
	35 × 40	5710	2.38	LLS1V183MELC
22000	35 × 45	6380	2.63	LLS1V223MELC
27000	35 × 50	6900	2.91	LLS1V273MELC

50V (1H)				
Cap. (μF)	Size φD × L(mm)	Rated ripple (mArms)	Leakage Current (mA)	Code
2200	22 × 25	1930	0.99	LLS1H222MELZ
2700	22 × 30	2210	1.10	LLS1H272MELZ
	22 × 30	2410	1.21	LLS1H332MELZ
3300	25 × 25	2380	1.21	LLS1H332MELA
	22 × 35	2720	1.32	LLS1H392MELZ
3900	25 × 30	2680	1.32	LLS1H392MELA
	22 × 40	3020	1.45	LLS1H472MELZ
4700	25 × 30	3070	1.45	LLS1H472MELA
	30 × 25	3010	1.45	LLS1H472MELB
	22 × 45	3430	1.58	LLS1H562MELZ
5600	25 × 35	3470	1.58	LLS1H562MELA
	30 × 30	3430	1.58	LLS1H562MELB
	22 × 50	3940	1.74	LLS1H682MELZ
6800	25 × 40	3870	1.74	LLS1H682MELA
	30 × 35	3930	1.74	LLS1H682MELB
	25 × 45	4440	1.92	LLS1H822MELA
8200	30 × 35	4470	1.92	LLS1H822MELB
	35 × 30	4410	1.92	LLS1H822MELC
	30 × 40	5080	2.12	LLS1H103MELB
10000	35 × 35	4920	2.12	LLS1H103MELC
	30 × 50	5720	2.32	LLS1H123MELB
12000	35 × 40	5690	2.32	LLS1H123MELC
	15000	35 × 45	6560	2.59
18000	35 × 50	7140	2.84	LLS1H183MELC

Rated ripple current (mArms) at 85°C 120Hz

# LLS

## ■ Dimensions

63V (1J)				
Cap. (μF)	Size φD × L(mm)	Rated ripple (mArms)	Leakage Current (mA)	Code
1800	22 × 25	1900	1.01	LLS1J182MELZ
	22 × 30	2350	1.11	LLS1J222MELZ
2200	25 × 25	2300	1.11	LLS1J222MELA
	22 × 35	2500	1.23	LLS1J272MELZ
2700	25 × 30	2520	1.23	LLS1J272MELA
	22 × 35	2720	1.36	LLS1J332MELZ
3300	25 × 30	2740	1.36	LLS1J332MELA
	30 × 25	2840	1.36	LLS1J332MELB
	22 × 40	3090	1.48	LLS1J392MELZ
3900	25 × 35	3130	1.48	LLS1J392MELA
	30 × 30	3090	1.48	LLS1J392MELB
	22 × 50	3690	1.63	LLS1J472MELZ
4700	25 × 40	3590	1.63	LLS1J472MELA
	30 × 30	3540	1.63	LLS1J472MELB
	25 × 45	4010	1.78	LLS1J562MELA
5600	30 × 35	4000	1.78	LLS1J562MELB
	35 × 30	3750	1.78	LLS1J562MELC
	25 × 50	4520	1.96	LLS1J682MELA
6800	30 × 40	4550	1.96	LLS1J682MELB
	35 × 30	4440	1.96	LLS1J682MELC
	30 × 45	5120	2.15	LLS1J822MELB
8200	35 × 35	5050	2.15	LLS1J822MELC
	30 × 50	5780	2.38	LLS1J103MELB
10000	35 × 40	5750	2.38	LLS1J103MELC
12000	35 × 45	6470	2.60	LLS1J123MELC

80V (1K)				
Cap. (μF)	Size φD × L(mm)	Rated ripple (mArms)	Leakage Current (mA)	Code
1200	22 × 25	1770	0.92	LLS1K122MELZ
1500	22 × 30	2010	1.03	LLS1K152MELZ
1800	22 × 30	2110	1.13	LLS1K182MELZ
	25 × 25	2260	1.13	LLS1K182MELA
2200	22 × 35	2530	1.25	LLS1K222MELZ
	25 × 30	2530	1.25	LLS1K222MELA
	30 × 25	2560	1.25	LLS1K222MELB
2700	22 × 40	2930	1.39	LLS1K272MELZ
	25 × 35	2930	1.39	LLS1K272MELA
	30 × 30	2910	1.39	LLS1K272MELB
3300	22 × 45	3230	1.54	LLS1K332MELZ
	25 × 40	3290	1.54	LLS1K332MELA
	30 × 30	3250	1.54	LLS1K332MELB
3900	22 × 50	3620	1.67	LLS1K392MELZ
	25 × 45	3710	1.67	LLS1K392MELA
	30 × 35	3700	1.67	LLS1K392MELB
4700	25 × 50	4280	1.83	LLS1K472MELA
	30 × 40	4230	1.83	LLS1K472MELB
	35 × 30	4120	1.83	LLS1K472MELC
5600	30 × 45	4700	2.00	LLS1K562MELB
	35 × 35	4640	2.00	LLS1K562MELC
6800	30 × 50	5270	2.21	LLS1K682MELB
	35 × 40	5240	2.21	LLS1K682MELC
8200	35 × 45	5890	2.42	LLS1K822MELC
10000	35 × 50	6630	2.68	LLS1K103MELC

100V (2A)				
Cap. (μF)	Size φD × L(mm)	Rated ripple (mArms)	Leakage Current (mA)	Code
820	22 × 25	1860	0.85	LLS2A821MELZ
1000	22 × 30	2020	0.94	LLS2A102MELZ
1200	22 × 30	2120	1.03	LLS2A122MELZ
	25 × 25	2110	1.03	LLS2A122MELA
1500	22 × 35	2450	1.16	LLS2A152MELZ
	25 × 30	2470	1.16	LLS2A152MELA
	30 × 25	2560	1.16	LLS2A152MELB
1800	22 × 40	2770	1.27	LLS2A182MELZ
	25 × 35	2810	1.27	LLS2A182MELA
	30 × 25	2650	1.27	LLS2A182MELB
2200	22 × 45	3150	1.40	LLS2A222MELZ
	25 × 40	3210	1.40	LLS2A222MELA
	30 × 30	3170	1.40	LLS2A222MELB
2700	25 × 45	3660	1.55	LLS2A272MELA
	30 × 35	3650	1.55	LLS2A272MELB
	35 × 30	3770	1.55	LLS2A272MELC
3300	25 × 50	4150	1.72	LLS2A332MELA
	30 × 40	4180	1.72	LLS2A332MELB
	35 × 35	4070	1.72	LLS2A332MELC
3900	30 × 45	4670	1.87	LLS2A392MELB
	35 × 35	4610	1.87	LLS2A392MELC
4700	30 × 50	5260	2.05	LLS2A472MELB
	35 × 40	5230	2.05	LLS2A472MELC
5600	35 × 45	5880	2.24	LLS2A562MELC
6800	35 × 50	6010	2.47	LLS2A682MELC

Rated ripple current (mArms) at 85°C 120Hz



■ Dimensions

160V (2C)				
Cap. (μF)	Size φD × L(mm)	Rated ripple (mArms)	Leakage Current (mA)	Code
270	20 × 25	1280	0.62	LLS2C271MELY
330	20 × 25	1550	0.68	LLS2C331MELY
390	20 × 30	1630	0.74	LLS2C391MELY
	22 × 25	1630	0.74	LLS2C391MELZ
470	20 × 30	1900	0.82	LLS2C471MELY
	22 × 30	1860	0.82	LLS2C471MELZ
	25 × 25	1860	0.82	LLS2C471MELA
560	20 × 35	2140	0.89	LLS2C561MELY
	22 × 30	2150	0.89	LLS2C561MELZ
	25 × 25	2150	0.89	LLS2C561MELA
680	20 × 40	2350	0.98	LLS2C681MELY
	22 × 35	2350	0.98	LLS2C681MELZ
	25 × 30	2330	0.98	LLS2C681MELA
	30 × 25	2330	0.98	LLS2C681MELB
820	22 × 40	2680	1.08	LLS2C821MELZ
	25 × 30	2650	1.08	LLS2C821MELA
	30 × 25	2640	1.08	LLS2C821MELB
1000	22 × 45	3020	1.20	LLS2C102MELZ
	25 × 35	3000	1.20	LLS2C102MELA
	30 × 30	2960	1.20	LLS2C102MELB
1200	25 × 40	3430	1.31	LLS2C122MELA
	30 × 30	3410	1.31	LLS2C122MELB
	35 × 25	3400	1.31	LLS2C122MELC
1500	25 × 50	3960	1.46	LLS2C152MELA
	30 × 35	3960	1.46	LLS2C152MELB
	35 × 30	3940	1.46	LLS2C152MELC
1800	30 × 40	4310	1.60	LLS2C182MELB
	35 × 35	4280	1.60	LLS2C182MELC
2200	30 × 50	4960	1.77	LLS2C222MELB
	35 × 40	4960	1.77	LLS2C222MELC
2700	35 × 45	5570	1.97	LLS2C272MELC

180V (2Z)				
Cap. (μF)	Size φD × L(mm)	Rated ripple (mArms)	Leakage Current (mA)	Code
270	20 × 25	1290	0.66	LLS2Z271MELY
330	20 × 30	1770	0.73	LLS2Z331MELY
	22 × 25	1770	0.73	LLS2Z331MELZ
390	20 × 30	1840	0.79	LLS2Z391MELY
	22 × 25	1840	0.79	LLS2Z391MELZ
470	20 × 35	1910	0.87	LLS2Z471MELY
	22 × 30	1910	0.87	LLS2Z471MELZ
	25 × 25	2080	0.87	LLS2Z471MELA
560	20 × 40	2150	0.95	LLS2Z561MELY
	22 × 35	2250	0.95	LLS2Z561MELZ
	25 × 25	2150	0.95	LLS2Z561MELA
680	22 × 35	2480	1.04	LLS2Z681MELZ
	25 × 30	2500	1.04	LLS2Z681MELA
	30 × 25	2460	1.04	LLS2Z681MELB
820	22 × 40	2860	1.15	LLS2Z821MELZ
	25 × 35	2750	1.15	LLS2Z821MELA
	30 × 25	2690	1.15	LLS2Z821MELB
1000	22 × 50	3100	1.27	LLS2Z102MELZ
	25 × 40	3060	1.27	LLS2Z102MELA
	30 × 30	3100	1.27	LLS2Z102MELB
1200	25 × 45	3630	1.39	LLS2Z122MELA
	30 × 35	3550	1.39	LLS2Z122MELB
	35 × 30	3490	1.39	LLS2Z122MELC
1500	30 × 40	4100	1.55	LLS2Z152MELB
	35 × 35	4020	1.55	LLS2Z152MELC
1800	30 × 45	4550	1.70	LLS2Z182MELB
	35 × 35	4540	1.70	LLS2Z182MELC
2200	35 × 40	4830	1.88	LLS2Z222MELC
2700	35 × 50	5300	2.09	LLS2Z272MELC

200V (2D)				
Cap. (μF)	Size φD × L(mm)	Rated ripple (mArms)	Leakage Current (mA)	Code
220	20 × 25	1190	0.62	LLS2D221MELY
270	20 × 25	1390	0.69	LLS2D271MELY
	22 × 25	1370	0.69	LLS2D271MELZ
330	20 × 30	1560	0.77	LLS2D331MELY
	22 × 25	1510	0.77	LLS2D331MELZ
390	20 × 35	1740	0.83	LLS2D391MELY
	22 × 30	1730	0.83	LLS2D391MELZ
	25 × 25	1710	0.83	LLS2D391MELA
470	20 × 35	2030	0.91	LLS2D471MELY
	22 × 30	1970	0.91	LLS2D471MELZ
	25 × 25	1950	0.91	LLS2D471MELA
560	20 × 40	2180	1.00	LLS2D561MELY
	22 × 35	2180	1.00	LLS2D561MELZ
	25 × 30	2150	1.00	LLS2D561MELA
	30 × 25	2150	1.00	LLS2D561MELB
680	22 × 40	2480	1.10	LLS2D681MELZ
	25 × 30	2480	1.10	LLS2D681MELA
	30 × 25	2480	1.10	LLS2D681MELB
820	22 × 45	2810	1.21	LLS2D821MELZ
	25 × 35	2790	1.21	LLS2D821MELA
	30 × 30	2800	1.21	LLS2D821MELB
1000	22 × 50	3280	1.34	LLS2D102MELZ
	25 × 40	3280	1.34	LLS2D102MELA
	30 × 35	3150	1.34	LLS2D102MELB
1200	30 × 35	3610	1.46	LLS2D122MELB
	35 × 30	3570	1.46	LLS2D122MELC
1500	30 × 45	4130	1.64	LLS2D152MELB
	35 × 35	4060	1.64	LLS2D152MELC
1800	30 × 50	4600	1.80	LLS2D182MELB
	35 × 40	4590	1.80	LLS2D182MELC
2200	35 × 45	5250	1.98	LLS2D222MELC

250V (2E)				
Cap. (μF)	Size φD × L(mm)	Rated ripple (mArms)	Leakage Current (mA)	Code
180	20 × 25	1200	0.63	LLS2E181MELY
220	20 × 25	1260	0.70	LLS2E221MELY
	22 × 25	1240	0.70	LLS2E221MELZ
270	20 × 30	1420	0.77	LLS2E271MELY
	22 × 25	1500	0.77	LLS2E271MELZ
330	20 × 35	1680	0.86	LLS2E331MELY
	22 × 30	1660	0.86	LLS2E331MELZ
	25 × 25	1610	0.86	LLS2E331MELA
390	20 × 40	1920	0.93	LLS2E391MELY
	22 × 35	1880	0.93	LLS2E391MELZ
	25 × 30	1880	0.93	LLS2E391MELA
470	22 × 35	2150	1.02	LLS2E471MELZ
	25 × 35	2150	1.02	LLS2E471MELA
	30 × 25	2040	1.02	LLS2E471MELB
560	22 × 40	2480	1.12	LLS2E561MELZ
	25 × 35	2350	1.12	LLS2E561MELA
	30 × 25	2350	1.12	LLS2E561MELB
680	25 × 40	2670	1.23	LLS2E681MELA
	30 × 30	2710	1.23	LLS2E681MELB
820	25 × 45	3010	1.35	LLS2E821MELA
	30 × 35	2980	1.35	LLS2E821MELB
	35 × 30	2960	1.35	LLS2E821MELC
1000	30 × 40	3560	1.50	LLS2E102MELB
	35 × 35	3480	1.50	LLS2E102MELC
1200	30 × 45	3990	1.64	LLS2E122MELB
	35 × 35	3840	1.64	LLS2E122MELC
1500	35 × 40	4330	1.83	LLS2E152MELC
1800	35 × 50	4540	2.01	LLS2E182MELC

Rated ripple current (mArms) at 85°C 120Hz



## ■ Dimensions

350V (2V)				
Cap. (μF)	Size φD × L(mm)	Rated ripple (mArms)	Leakage Current (mA)	Code
120	20 × 30	960	0.61	LLS2V121MELY
	22 × 25	1040	0.61	LLS2V121MELZ
150	20 × 30	1100	0.68	LLS2V151MELY
	22 × 30	1200	0.68	LLS2V151MELZ
	25 × 25	1220	0.68	LLS2V151MELA
180	20 × 35	1240	0.75	LLS2V181MELY
	22 × 30	1340	0.75	LLS2V181MELZ
	25 × 25	1370	0.75	LLS2V181MELA
220	22 × 35	1470	0.83	LLS2V221MELZ
	25 × 30	1530	0.83	LLS2V221MELA
	30 × 25	1540	0.83	LLS2V221MELB
270	22 × 40	1700	0.92	LLS2V271MELZ
	25 × 35	1730	0.92	LLS2V271MELA
	30 × 25	1800	0.92	LLS2V271MELB
330	22 × 45	1870	1.01	LLS2V331MELZ
	25 × 35	1970	1.01	LLS2V331MELA
	30 × 30	2030	1.01	LLS2V331MELB
390	25 × 40	2140	1.10	LLS2V391MELA
	30 × 35	2230	1.10	LLS2V391MELB
	35 × 30	2300	1.10	LLS2V391MELC
470	25 × 50	2550	1.21	LLS2V471MELA
	30 × 35	2530	1.21	LLS2V471MELB
	35 × 30	2550	1.21	LLS2V471MELC
560	30 × 40	2730	1.32	LLS2V561MELB
	35 × 35	2750	1.32	LLS2V561MELC
680	30 × 50	3150	1.46	LLS2V681MELB
	35 × 40	3150	1.46	LLS2V681MELC
820	35 × 45	3470	1.60	LLS2V821MELC
1000	35 × 50	3600	1.77	LLS2V102MELC

400V (2G)				
Cap. (μF)	Size φD × L(mm)	Rated ripple (mArms)	Leakage Current (mA)	Code
68	20 × 25	750	0.49	LLS2G680MELY
82	20 × 30	820	0.54	LLS2G820MELY
	22 × 25	840	0.54	LLS2G820MELZ
100	20 × 30	950	0.60	LLS2G101MELY
	22 × 25	950	0.60	LLS2G101MELZ
120	20 × 35	1070	0.65	LLS2G121MELY
	22 × 30	1090	0.65	LLS2G121MELZ
	25 × 25	1130	0.65	LLS2G121MELA
150	20 × 40	1220	0.73	LLS2G151MELY
	22 × 35	1240	0.73	LLS2G151MELZ
	25 × 30	1270	0.73	LLS2G151MELA
180	22 × 40	1410	0.80	LLS2G181MELZ
	25 × 30	1440	0.80	LLS2G181MELA
	30 × 25	1520	0.80	LLS2G181MELB
220	22 × 45	1580	0.88	LLS2G221MELZ
	25 × 35	1640	0.88	LLS2G221MELA
	30 × 30	1660	0.88	LLS2G221MELB
270	25 × 40	1790	0.98	LLS2G271MELA
	30 × 30	1820	0.98	LLS2G271MELB
330	25 × 45	2000	1.08	LLS2G331MELA
	30 × 35	2050	1.08	LLS2G331MELB
	35 × 30	2050	1.08	LLS2G331MELC
390	30 × 40	2260	1.18	LLS2G391MELB
	35 × 35	2280	1.18	LLS2G391MELC
470	30 × 45	2510	1.30	LLS2G471MELB
	35 × 35	2510	1.30	LLS2G471MELC
560	30 × 50	2850	1.41	LLS2G561MELB
	35 × 40	2850	1.41	LLS2G561MELC
680	35 × 50	3100	1.56	LLS2G681MELC

450V (2W)				
Cap. (μF)	Size φD × L(mm)	Rated ripple (mArms)	Leakage Current (mA)	Code
56	20 × 25	610	0.47	LLS2W560MELY
68	20 × 30	710	0.52	LLS2W680MELY
	22 × 25	710	0.52	LLS2W680MELZ
82	20 × 35	800	0.57	LLS2W820MELY
	22 × 25	860	0.57	LLS2W820MELZ
100	20 × 35	880	0.63	LLS2W101MELY
	22 × 30	950	0.63	LLS2W101MELZ
	25 × 25	970	0.63	LLS2W101MELA
120	20 × 40	990	0.69	LLS2W121MELY
	22 × 35	1070	0.69	LLS2W121MELZ
	25 × 30	1090	0.69	LLS2W121MELA
	30 × 25	1120	0.69	LLS2W121MELB
150	22 × 40	1180	0.77	LLS2W151MELZ
	25 × 30	1250	0.77	LLS2W151MELA
	30 × 25	1290	0.77	LLS2W151MELB
180	22 × 45	1320	0.85	LLS2W181MELZ
	25 × 35	1400	0.85	LLS2W181MELA
	30 × 30	1450	0.85	LLS2W181MELB
220	25 × 40	1590	0.94	LLS2W221MELA
	30 × 30	1640	0.94	LLS2W221MELB
	35 × 25	1590	0.94	LLS2W221MELC
270	30 × 35	1890	1.04	LLS2W271MELB
	35 × 30	1900	1.04	LLS2W271MELC
330	30 × 40	2120	1.15	LLS2W331MELB
	35 × 35	2150	1.15	LLS2W331MELC
390	30 × 45	2350	1.25	LLS2W391MELB
	35 × 40	2380	1.25	LLS2W391MELC
470	35 × 45	2680	1.37	LLS2W471MELC
560	35 × 50	2880	1.50	LLS2W561MELC

Rated ripple current (mArms) at 85°C 120Hz

# ALUMINUM ELECTROLYTIC CAPACITORS

# LLG

Snap-in Terminal Type, 85°C Smaller-Sized



Smaller

- One rank smaller case sized than LLS.
- Suited for equipment down sizing.
- Compliant to the RoHS directive (2011/65/EU,(EU)2015/863).

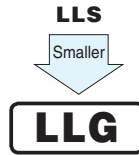

## Specifications

Item	Performance Characteristics				
Category Temperature Range	- 40 to + 85°C (160 to 250V), - 25 to + 85°C (400 to 450V)				
Rated Voltage Range	160 to 450V				
Rated Capacitance Range	120 to 3900μF				
Capacitance Tolerance	± 20% at 120Hz, 20°C				
Leakage Current	$I \leq 3\sqrt{CV}$ (μA) (After 5 minutes' application of rated voltage) [C : Rated Capacitance (μF) V : Voltage (V)]				
Tangent of loss angle (tan δ)	Rated voltage (V)	160 to 400	450	Measurement frequency : 120Hz at 20°C	
	tan δ (MAX.)	0.15	0.20		
Stability at Low Temperature	Rated voltage(V)	160 to 250	400 • 450	Measurement frequency : 120Hz	
	Impedance ratio ZT/Z20 (MAX.)	Z - 25°C/Z+20°C	4		8
Endurance	The specifications listed at right shall be met when the capacitors are restored to 20°C after D.C. bias plus rated ripple current is applied for 2000 hours at 85°C, the peak voltage shall not exceed the rated voltage.			Capacitance change	Within ±20% of the initial capacitance value
				tan δ	200% or less than the initial specified value
				Leakage current	Less than or equal to the initial specified value
Shelf Life	After storing the capacitors under no load at 85°C for 1000 hours and then performing voltage treatment based on JIS C 5101-4 clause 4.1 at 20°C, they shall meet the characteristic requirements listed at right.			Capacitance change	Within ±20% of the initial capacitance value
				tan δ	200% or less than the initial specified value
				Leakage current	Less than or equal to the initial specified value
Marking	Printed with white color letter on black sleeve.				

## Drawing

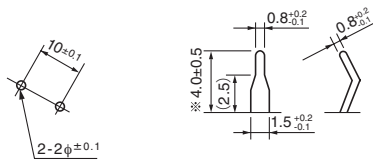
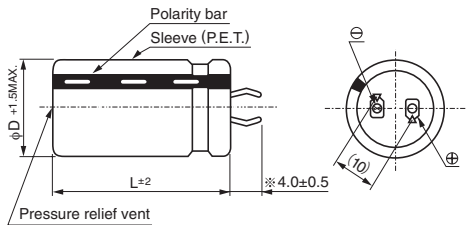

(PC board hole dimensions) (Terminal dimensions)

## Type numbering system ( Example : 400V 180μF )

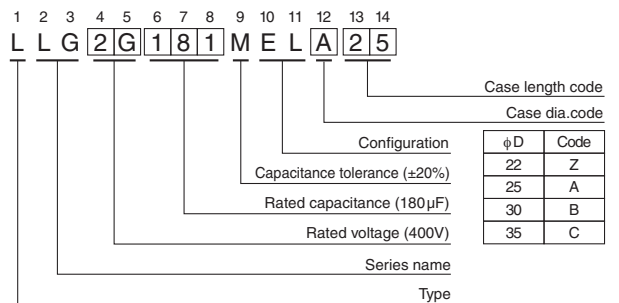

※ Other terminations available upon request.  
Please refer to the Guidelines for Aluminum Electrolytic Capacitors.

Minimum order quantity : 50pcs.

● Dimension table in next page.



## ■ Dimensions

160V (2C)				
Cap. (μF)	Size φD × L(mm)	Rated ripple (mArms)	Leakage Current (mA)	Code
560	22 × 25	2250	0.89	LLG2C561MELZ25
680	22 × 30	2500	0.98	LLG2C681MELZ30
820	22 × 35	2750	1.08	LLG2C821MELZ35
	25 × 25	2520	1.08	LLG2C821MELA25
1000	22 × 40	3000	1.20	LLG2C102MELZ40
	25 × 30	3000	1.20	LLG2C102MELA30
1200	22 × 40	3050	1.31	LLG2C122MELZ40
	25 × 35	3250	1.31	LLG2C122MELA35
	30 × 25	3050	1.31	LLG2C122MELB25
1500	22 × 50	3400	1.46	LLG2C152MELZ50
	25 × 40	3400	1.46	LLG2C152MELA40
	30 × 30	3400	1.46	LLG2C152MELB30
	35 × 25	3400	1.46	LLG2C152MELC25
1800	25 × 45	3800	1.60	LLG2C182MELA45
	30 × 35	4200	1.60	LLG2C182MELB35
	35 × 30	4100	1.60	LLG2C182MELC30
2200	30 × 40	4450	1.77	LLG2C222MELB40
	35 × 35	4780	1.77	LLG2C222MELC35
2700	30 × 45	4900	1.97	LLG2C272MELB45
	35 × 40	5450	1.97	LLG2C272MELC40
3300	35 × 45	5750	2.17	LLG2C332MELC45
3900	35 × 50	6000	2.36	LLG2C392MELC50

180V (2Z)				
Cap. (μF)	Size φD × L(mm)	Rated ripple (mArms)	Leakage Current (mA)	Code
560	22 × 25	1800	0.95	LLG2Z561MELZ25
680	22 × 30	1900	1.04	LLG2Z681MELZ30
	25 × 25	2100	1.04	LLG2Z681MELA25
820	22 × 35	2450	1.15	LLG2Z821MELZ35
	25 × 30	2400	1.15	LLG2Z821MELA30
1000	22 × 40	2800	1.27	LLG2Z102MELZ40
	25 × 35	2700	1.27	LLG2Z102MELA35
	30 × 25	2650	1.27	LLG2Z102MELB25
1200	22 × 45	2900	1.39	LLG2Z122MELZ45
	25 × 40	3000	1.39	LLG2Z122MELA40
	30 × 30	3000	1.39	LLG2Z122MELB30
	35 × 25	3000	1.39	LLG2Z122MELC25
1500	25 × 45	3300	1.55	LLG2Z152MELA45
	30 × 35	3300	1.55	LLG2Z152MELB35
	35 × 30	3300	1.55	LLG2Z152MELC30
1800	25 × 50	3600	1.70	LLG2Z182MELA50
	30 × 40	3600	1.70	LLG2Z182MELB40
	35 × 30	3400	1.70	LLG2Z182MELC30
2200	30 × 45	4300	1.88	LLG2Z222MELB45
	35 × 35	4300	1.88	LLG2Z222MELC35
2700	30 × 50	4700	2.09	LLG2Z272MELB50
	35 × 40	4700	2.09	LLG2Z272MELC40
3300	35 × 45	5000	2.31	LLG2Z332MELC45

200V (2D)				
Cap. (μF)	Size φD × L(mm)	Rated ripple (mArms)	Leakage Current (mA)	Code
470	22 × 25	1430	0.91	LLG2D471MELZ25
560	22 × 30	2070	1.00	LLG2D561MELZ30
	25 × 25	2070	1.00	LLG2D561MELA25
680	22 × 35	2280	1.10	LLG2D681MELZ35
	25 × 30	2280	1.10	LLG2D681MELA30
820	22 × 40	2490	1.21	LLG2D821MELZ40
	25 × 30	2340	1.21	LLG2D821MELA30
1000	22 × 45	2550	1.34	LLG2D102MELZ45
	25 × 35	2550	1.34	LLG2D102MELA35
	30 × 30	2760	1.34	LLG2D102MELB30
1200	22 × 50	2810	1.46	LLG2D122MELZ50
	25 × 40	2810	1.46	LLG2D122MELA40
	30 × 30	2810	1.46	LLG2D122MELB30
	35 × 25	2810	1.46	LLG2D122MELC25
1500	25 × 50	3290	1.64	LLG2D152MELA50
	30 × 35	2980	1.64	LLG2D152MELB35
	35 × 30	3290	1.64	LLG2D152MELC30
1800	30 × 40	3320	1.80	LLG2D182MELB40
	35 × 35	3670	1.80	LLG2D182MELC35
2200	30 × 50	4180	1.98	LLG2D222MELB50
	35 × 40	4180	1.98	LLG2D222MELC40
2700	35 × 45	4340	2.20	LLG2D272MELC45
3300	35 × 50	4420	2.55	LLG2D332MELC50

250V (2E)				
Cap. (μF)	Size φD × L(mm)	Rated ripple (mArms)	Leakage Current (mA)	Code
330	22 × 25	1300	0.86	LLG2E331MELZ25
390	22 × 30	1910	0.93	LLG2E391MELZ30
470	25 × 25	2000	1.02	LLG2E471MELA25
560	22 × 40	2250	1.12	LLG2E561MELZ40
	25 × 30	2250	1.12	LLG2E561MELA30
680	22 × 45	2500	1.23	LLG2E681MELZ45
	25 × 35	2500	1.23	LLG2E681MELA35
	30 × 25	2500	1.23	LLG2E681MELB25
820	25 × 40	2770	1.35	LLG2E821MELA40
	30 × 30	2770	1.35	LLG2E821MELB30
	35 × 25	2770	1.35	LLG2E821MELC25
1000	25 × 50	3320	1.50	LLG2E102MELA50
	30 × 35	3320	1.50	LLG2E102MELB35
	35 × 30	3320	1.50	LLG2E102MELC30
1200	30 × 40	3840	1.64	LLG2E122MELB40
	35 × 35	3840	1.64	LLG2E122MELC35
1500	30 × 50	4250	1.83	LLG2E152MELB50
	35 × 40	4250	1.83	LLG2E152MELC40
1800	35 × 45	4550	2.01	LLG2E182MELC45
2200	35 × 50	4750	2.22	LLG2E222MELC50

Rated ripple current (mArms) at 85°C 120Hz



## ■ Dimensions

400V (2G)				
Cap. (μF)	Size φD × L(mm)	Rated ripple (mArms)	Leakage Current (mA)	Code
150	22 × 25	1030	0.73	LLG2G151MELZ25
180	22 × 30	1160	0.80	LLG2G181MELZ30
	25 × 25	1160	0.80	LLG2G181MELA25
220	22 × 35	1400	0.88	LLG2G221MELZ35
	25 × 30	1400	0.88	LLG2G221MELA30
270	22 × 40	1500	0.98	LLG2G271MELZ40
	25 × 35	1500	0.98	LLG2G271MELA35
330	22 × 45	1700	1.08	LLG2G331MELZ45
	25 × 35	1700	1.08	LLG2G331MELA35
	30 × 30	1700	1.08	LLG2G331MELB30
390	22 × 50	1900	1.18	LLG2G391MELZ50
	25 × 40	1900	1.18	LLG2G391MELA40
	30 × 30	1900	1.18	LLG2G391MELB30
	35 × 25	1900	1.18	LLG2G391MELC25
470	25 × 50	2130	1.30	LLG2G471MELA50
	30 × 35	2130	1.30	LLG2G471MELB35
	35 × 30	2130	1.30	LLG2G471MELC30
560	30 × 40	2390	1.41	LLG2G561MELB40
	35 × 35	2390	1.41	LLG2G561MELC35
680	30 × 45	2690	1.56	LLG2G681MELB45
	35 × 35	2690	1.56	LLG2G681MELC35
820	35 × 40	2960	1.71	LLG2G821MELC40
1000	35 × 50	3300	1.89	LLG2G102MELC50

450V (2W)				
Cap. (μF)	Size φD × L(mm)	Rated ripple (mArms)	Leakage Current (mA)	Code
120	22 × 25	930	0.69	LLG2W121MELZ25
150	22 × 30	1040	0.77	LLG2W151MELZ30
	25 × 25	1040	0.77	LLG2W151MELA25
180	22 × 35	1300	0.85	LLG2W181MELZ35
	25 × 30	1300	0.85	LLG2W181MELA30
220	22 × 40	1400	0.94	LLG2W221MELZ40
	25 × 35	1500	0.94	LLG2W221MELA35
	30 × 25	1400	0.94	LLG2W221MELB25
270	22 × 45	1660	1.04	LLG2W271MELZ45
	25 × 40	1800	1.04	LLG2W271MELA40
	30 × 30	1800	1.04	LLG2W271MELB30
330	25 × 45	1950	1.15	LLG2W331MELA45
	30 × 35	1950	1.15	LLG2W331MELB35
	35 × 30	1950	1.15	LLG2W331MELC30
390	25 × 50	2100	1.25	LLG2W391MELA50
	30 × 35	2100	1.25	LLG2W391MELB35
	35 × 30	2100	1.25	LLG2W391MELC30
470	30 × 40	2320	1.37	LLG2W471MELB40
	35 × 35	2320	1.37	LLG2W471MELC35
560	30 × 50	2660	1.50	LLG2W561MELB50
	35 × 40	2660	1.50	LLG2W561MELC40
680	35 × 45	2820	1.65	LLG2W681MELC45
820	35 × 50	3000	1.82	LLG2W821MELC50

Rated ripple current (mArms) at 85°C 120Hz

## ● Frequency coefficient of rated ripple current

Frequency (Hz)		50	60	120	300	1k	10k	50k or more
coeff	160 to 250V	0.81	0.85	1.00	1.17	1.32	1.45	1.50
	400 • 450V	0.77	0.82	1.00	1.16	1.30	1.41	1.43



# ALUMINUM ELECTROLYTIC CAPACITORS

# LGU

Snap-in Terminal Type, 105°C Standard



Anti-Solvent Feature (Through 100V only)

- Withstanding 3000 hours application of rated ripple current at 105°C.
- Compliant to the RoHS directive (2011/65/EU,(EU)2015/863).

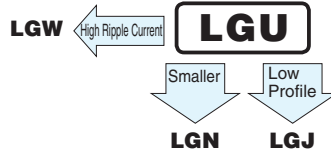

## Specifications

Item	Performance Characteristics	
Category Temperature Range	- 40 to + 105°C (16 to 250V) , - 25 to +105°C (315 to 450V)	
Rated Voltage Range	16 to 450V	
Rated Capacitance Range	47 to 47000μF	
Capacitance Tolerance	±20% at 120Hz, 20°C	
Leakage Current	$I \leq 3\sqrt{CV}$ (μA) (After 5 minutes' application of rated voltage) [C : Rated Capacitance (μF) V : Voltage (V)]	
Tangent of loss angle (tan δ)	Measurement frequency : 120Hz at 20°C	
	Rated voltage(V)	16    25    35    50    63    80·100    160 to 420    450
	tan δ (MAX.)	0.50    0.40    0.35    0.30    0.25    0.20    0.15    0.20
Stability at Low Temperature	Measurement frequency : 120Hz	
	Rated voltage (V)	
	Impedance ratio	Z - 25°C/Z+20°C    4    3    8
	ZT/Z20 (MAX.)	Z - 40°C/Z+20°C    20    12    —
Endurance	The specifications listed at right shall be met when the capacitors are restored to 20°C after D.C. bias plus rated ripple current is applied for 3000 hours at 105°C, the peak voltage shall not exceed the rated voltage.	
	Capacitance change	Within ±20% of the initial capacitance value
	tan δ	200% or less than the initial specified value
Shelf Life	After storing the capacitors under no load at 105°C for 1000 hours and then performing voltage treatment based on JIS C 5101-4 clause 4.1 at 20°C, they shall meet the characteristic requirements listed at right.	
	Capacitance change	Within ±15% of the initial capacitance value
	tan δ	150% or less than the initial specified value
Leakage current	Less than or equal to the initial specified value	
Marking	Printed with white color letter on black sleeve.	

## Drawing

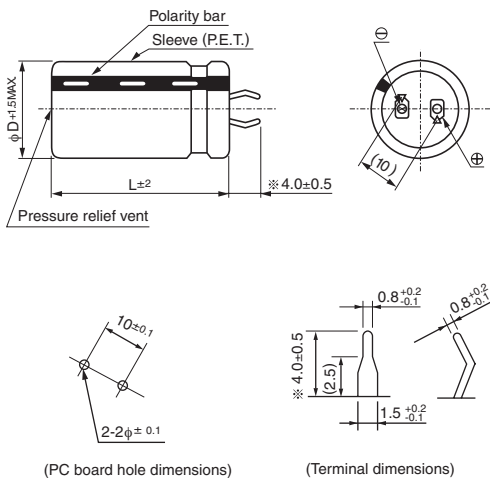

## Type numbering system (Example : 200V 680μF)

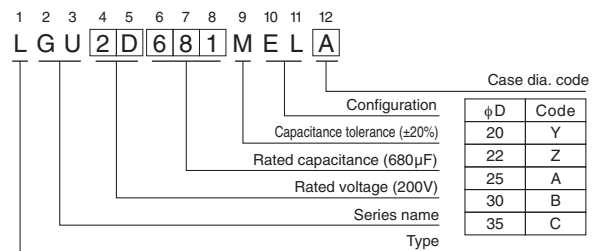

※ Other terminations available upon request.  
Please refer to the Guidelines for Aluminum Electrolytic Capacitors.

## Frequency coefficient of rated ripple current

Frequency (Hz)	50	60	120	300	1k	10k	50k or more
Coeff.	16 to 100V	0.88	0.90	1.00	1.07	1.15	1.15
	160 to 250V	0.81	0.85	1.00	1.17	1.32	1.45
	315 to 450V	0.77	0.82	1.00	1.16	1.30	1.41

Minimum order quantity : 50pcs.

• Dimension table in next page.



## ■ Dimensions

16V (1C)				
Cap. (μF)	Size φD×L (mm)	Rated ripple (mArms)	Leakage Current (mA)	Code
6800	22 × 25	1750	0.98	LGU1C682MELZ
8200	22 × 30	2000	1.08	LGU1C822MELZ
10000	22 × 30	2100	1.20	LGU1C103MELZ
	25 × 25	2050	1.20	LGU1C103MELA
12000	22 × 35	2310	1.31	LGU1C123MELZ
	25 × 30	2300	1.31	LGU1C123MELA
	30 × 25	2380	1.31	LGU1C123MELB
15000	22 × 40	2680	1.46	LGU1C153MELZ
	25 × 35	2680	1.46	LGU1C153MELA
	30 × 30	2570	1.46	LGU1C153MELB
18000	22 × 45	2980	1.60	LGU1C183MELZ
	25 × 40	3160	1.60	LGU1C183MELA
	30 × 30	3000	1.60	LGU1C183MELB
22000	25 × 45	3400	1.77	LGU1C223MELA
	30 × 35	3390	1.77	LGU1C223MELB
	35 × 30	3250	1.77	LGU1C223MELC
27000	25 × 50	3850	1.97	LGU1C273MELA
	30 × 40	3830	1.97	LGU1C273MELB
	35 × 30	3740	1.97	LGU1C273MELC
33000	30 × 45	4300	2.17	LGU1C333MELB
	35 × 35	4270	2.17	LGU1C333MELC
39000	30 × 50	4810	2.36	LGU1C393MELB
	35 × 40	4800	2.36	LGU1C393MELC
47000	35 × 45	5530	2.60	LGU1C473MELC

25V (1E)				
Cap. (μF)	Size φD×L (mm)	Rated ripple (mArms)	Leakage Current (mA)	Code
4700	22 × 25	1610	1.02	LGU1E472MELZ
5600	22 × 30	1800	1.12	LGU1E562MELZ
6800	22 × 30	1910	1.23	LGU1E682MELZ
	25 × 25	1910	1.23	LGU1E682MELA
8200	22 × 35	2140	1.35	LGU1E822MELZ
	25 × 30	2340	1.35	LGU1E822MELA
	30 × 25	2250	1.35	LGU1E822MELB
10000	22 × 40	2650	1.50	LGU1E103MELZ
	25 × 35	2610	1.50	LGU1E103MELA
	30 × 30	2610	1.50	LGU1E103MELB
12000	22 × 45	2690	1.64	LGU1E123MELZ
	25 × 40	2810	1.64	LGU1E123MELA
	30 × 30	2740	1.64	LGU1E123MELB
15000	25 × 45	3270	1.83	LGU1E153MELA
	30 × 35	3130	1.83	LGU1E153MELB
	35 × 30	3260	1.83	LGU1E153MELC
18000	25 × 50	3540	2.01	LGU1E183MELA
	30 × 40	3560	2.01	LGU1E183MELB
	35 × 35	3840	2.01	LGU1E183MELC
22000	30 × 45	4240	2.22	LGU1E223MELB
	35 × 35	3960	2.22	LGU1E223MELC
27000	35 × 45	4750	2.46	LGU1E273MELC
33000	35 × 50	5500	2.72	LGU1E333MELC

35V (1V)				
Cap. (μF)	Size φD×L (mm)	Rated ripple (mArms)	Leakage Current (mA)	Code
3300	22 × 25	1450	1.01	LGU1V332MELZ
3900	22 × 30	1690	1.10	LGU1V392MELZ
4700	22 × 35	2020	1.21	LGU1V472MELZ
	25 × 25	1780	1.21	LGU1V472MELA
5600	22 × 35	2130	1.32	LGU1V562MELZ
	25 × 30	2040	1.32	LGU1V562MELA
	30 × 25	2120	1.32	LGU1V562MELB
6800	22 × 40	2410	1.46	LGU1V682MELZ
	25 × 35	2310	1.46	LGU1V682MELA
	30 × 25	2310	1.46	LGU1V682MELB
8200	22 × 50	2850	1.60	LGU1V822MELZ
	25 × 40	2730	1.60	LGU1V822MELA
	30 × 30	2750	1.60	LGU1V822MELB
10000	25 × 45	3050	1.77	LGU1V103MELA
	30 × 35	3050	1.77	LGU1V103MELB
	25 × 50	3370	1.94	LGU1V123MELA
12000	30 × 40	3280	1.94	LGU1V123MELB
	35 × 30	3200	1.94	LGU1V123MELC
	30 × 45	3740	2.17	LGU1V153MELB
15000	35 × 35	3690	2.17	LGU1V153MELC
	18000	35 × 40	4370	2.38
22000	35 × 50	4920	2.63	LGU1V223MELC

50V (1H)				
Cap. (μF)	Size φD×L (mm)	Rated ripple (mArms)	Leakage Current (mA)	Code
1800	22 × 25	1340	0.90	LGU1H182MELZ
2700	22 × 30	1700	1.10	LGU1H272MELZ
	25 × 25	1700	1.10	LGU1H272MELA
3300	22 × 35	1980	1.21	LGU1H332MELZ
	25 × 30	2000	1.21	LGU1H332MELA
3900	22 × 40	2250	1.32	LGU1H392MELZ
	25 × 30	2280	1.32	LGU1H392MELA
	30 × 25	2220	1.32	LGU1H392MELB
4700	22 × 45	2560	1.45	LGU1H472MELZ
	25 × 35	2610	1.45	LGU1H472MELA
	30 × 30	2580	1.45	LGU1H472MELB
5600	22 × 50	2890	1.58	LGU1H562MELZ
	25 × 40	2810	1.58	LGU1H562MELA
	30 × 30	2950	1.58	LGU1H562MELB
6800	25 × 45	3370	1.74	LGU1H682MELA
	30 × 35	3390	1.74	LGU1H682MELB
	35 × 30	3310	1.74	LGU1H682MELC
8200	30 × 40	3710	1.92	LGU1H822MELB
	35 × 35	3660	1.92	LGU1H822MELC
10000	30 × 50	4090	2.12	LGU1H103MELB
	35 × 40	4070	2.12	LGU1H103MELC
12000	35 × 45	4560	2.32	LGU1H123MELC
15000	35 × 50	4770	2.59	LGU1H153MELC

Rated ripple current (mArms) at 105°C 120Hz



## ■ Dimensions

63V (1J)				
Cap. (μF)	Size φD×L (mm)	Rated ripple (mArms)	Leakage Current (mA)	Code
1200	22 × 25	1250	0.82	LGU1J122MELZ
1500	22 × 30	1470	0.92	LGU1J152MELZ
	25 × 25	1440	0.92	LGU1J152MELA
1800	22 × 30	1580	1.01	LGU1J182MELZ
	25 × 25	1520	1.01	LGU1J182MELA
2200	22 × 35	1820	1.11	LGU1J222MELZ
	25 × 30	1750	1.11	LGU1J222MELA
2700	22 × 40	2070	1.23	LGU1J272MELZ
	25 × 35	2110	1.23	LGU1J272MELA
	30 × 25	1930	1.23	LGU1J272MELB
3300	22 × 45	2330	1.36	LGU1J332MELZ
	25 × 35	2270	1.36	LGU1J332MELA
	30 × 30	2240	1.36	LGU1J332MELB
3900	25 × 40	2540	1.48	LGU1J392MELA
	30 × 35	2550	1.48	LGU1J392MELB
4700	25 × 50	2970	1.63	LGU1J472MELA
	30 × 40	2900	1.63	LGU1J472MELB
	35 × 30	2830	1.63	LGU1J472MELC
5600	30 × 40	3280	1.78	LGU1J562MELB
	35 × 35	3240	1.78	LGU1J562MELC
6800	30 × 50	3730	1.96	LGU1J682MELB
	35 × 40	3710	1.96	LGU1J682MELC
8200	35 × 45	4160	2.15	LGU1J822MELC
10000	35 × 50	4690	2.38	LGU1J103MELC

80V (1K)				
Cap. (μF)	Size φD×L (mm)	Rated ripple (mArms)	Leakage Current (mA)	Code
820	22 × 25	1110	0.76	LGU1K821MELZ
1000	22 × 25	1290	0.84	LGU1K102MELZ
1200	22 × 30	1440	0.92	LGU1K122MELZ
	25 × 25	1390	0.92	LGU1K122MELA
1500	22 × 30	1610	1.03	LGU1K152MELZ
	25 × 25	1620	1.03	LGU1K152MELA
1800	22 × 35	1830	1.13	LGU1K182MELZ
	25 × 30	1860	1.13	LGU1K182MELA
	30 × 25	1810	1.13	LGU1K182MELB
2200	22 × 40	2090	1.25	LGU1K222MELZ
	25 × 35	2010	1.25	LGU1K222MELA
	30 × 25	2100	1.25	LGU1K222MELB
2700	25 × 40	2430	1.39	LGU1K272MELA
	30 × 30	2430	1.39	LGU1K272MELB
3300	25 × 45	2760	1.54	LGU1K332MELA
	30 × 35	2780	1.54	LGU1K332MELB
	35 × 30	2710	1.54	LGU1K332MELC
3900	25 × 50	2920	1.67	LGU1K392MELA
	30 × 40	3120	1.67	LGU1K392MELB
	35 × 30	3070	1.67	LGU1K392MELC
4700	30 × 45	3520	1.83	LGU1K472MELB
	35 × 35	3500	1.83	LGU1K472MELC
5600	30 × 50	3800	2.00	LGU1K562MELB
	35 × 40	3870	2.00	LGU1K562MELC
6800	35 × 45	4190	2.21	LGU1K682MELC

100V (2A)				
Cap. (μF)	Size φD×L (mm)	Rated ripple (mArms)	Leakage Current (mA)	Code
560	22 × 25	1070	0.70	LGU2A561MELZ
820	22 × 30	1350	0.85	LGU2A821MELZ
	25 × 25	1350	0.85	LGU2A821MELA
1000	22 × 30	1540	0.94	LGU2A102MELZ
	25 × 30	1560	0.94	LGU2A102MELA
1200	22 × 40	1740	1.03	LGU2A122MELZ
	25 × 30	1760	1.03	LGU2A122MELA
1500	30 × 25	1710	1.03	LGU2A122MELB
	22 × 45	1990	1.16	LGU2A152MELZ
	25 × 35	2030	1.16	LGU2A152MELA
1800	30 × 30	2000	1.16	LGU2A152MELB
	25 × 40	2280	1.27	LGU2A182MELA
2200	30 × 35	2270	1.27	LGU2A182MELB
	25 × 50	2570	1.40	LGU2A222MELA
2700	30 × 35	2590	1.40	LGU2A222MELB
	35 × 30	2520	1.40	LGU2A222MELC
3300	30 × 45	2940	1.55	LGU2A272MELB
	35 × 35	2900	1.55	LGU2A272MELC
3900	30 × 50	3320	1.72	LGU2A332MELB
	35 × 40	3310	1.72	LGU2A332MELC
4700	35 × 45	3690	1.87	LGU2A392MELC
4700	35 × 50	4140	2.05	LGU2A472MELC

160V (2C)				
Cap. (μF)	Size φD×L (mm)	Rated ripple (mArms)	Leakage Current (mA)	Code
270	20 × 25	1100	0.62	LGU2C271MELZ
330	20 × 30	1200	0.68	LGU2C331MELZ
390	20 × 30	1300	0.74	LGU2C391MELZ
	22 × 25	1300	0.74	LGU2C391MELA
470	20 × 35	1340	0.82	LGU2C471MELZ
	22 × 30	1550	0.82	LGU2C471MELZ
	25 × 25	1550	0.82	LGU2C471MELA
560	20 × 40	1500	0.89	LGU2C561MELZ
	22 × 35	1670	0.89	LGU2C561MELZ
	25 × 30	1670	0.89	LGU2C561MELA
	30 × 25	1670	0.89	LGU2C561MELB
680	20 × 45	1700	0.98	LGU2C681MELZ
	22 × 40	1820	0.98	LGU2C681MELZ
	25 × 30	1820	0.98	LGU2C681MELA
820	30 × 25	1820	0.98	LGU2C681MELB
	22 × 45	2040	1.08	LGU2C821MELZ
	25 × 35	2040	1.08	LGU2C821MELA
1000	30 × 30	2040	1.08	LGU2C821MELB
	35 × 25	2040	1.08	LGU2C821MELC
	22 × 50	2250	1.20	LGU2C102MELZ
	25 × 40	2250	1.20	LGU2C102MELA
1200	30 × 30	2250	1.20	LGU2C102MELB
	35 × 25	2250	1.20	LGU2C102MELC
	25 × 45	2490	1.31	LGU2C122MELA
1500	30 × 35	2490	1.31	LGU2C122MELB
	35 × 30	2490	1.31	LGU2C122MELC
1800	30 × 40	2840	1.46	LGU2C152MELB
	35 × 30	2840	1.46	LGU2C152MELC
2200	30 × 45	3320	1.60	LGU2C182MELB
	35 × 35	3000	1.60	LGU2C182MELC
2700	35 × 45	3500	1.77	LGU2C222MELC
2700	35 × 50	4000	1.97	LGU2C272MELC

Rated ripple current (mArms) at 105°C 120Hz



## ■ Dimensions

180V (2Z)				
Cap.(μF)	Size φD×L(mm)	Rated ripple (mArms)	Leakage Current (mA)	Code
220	20 × 25	1000	0.59	LGU2Z221MELY
270	20 × 30	1100	0.66	LGU2Z271MELY
330	20 × 30	1200	0.73	LGU2Z331MELY
	22 × 25	1200	0.73	LGU2Z331MELZ
390	20 × 35	1300	0.79	LGU2Z391MELY
	22 × 30	1350	0.79	LGU2Z391MELZ
	25 × 25	1350	0.79	LGU2Z391MELA
470	20 × 40	1400	0.87	LGU2Z471MELY
	22 × 35	1500	0.87	LGU2Z471MELZ
	25 × 30	1500	0.87	LGU2Z471MELA
	30 × 25	1500	0.87	LGU2Z471MELB
560	20 × 45	1550	0.95	LGU2Z561MELY
	22 × 40	1670	0.95	LGU2Z561MELZ
	25 × 30	1670	0.95	LGU2Z561MELA
	30 × 25	1670	0.95	LGU2Z561MELB
680	22 × 45	1780	1.04	LGU2Z681MELZ
	25 × 35	1780	1.04	LGU2Z681MELA
	30 × 30	1780	1.04	LGU2Z681MELB
	35 × 25	1780	1.04	LGU2Z681MELC
820	22 × 50	2040	1.15	LGU2Z821MELZ
	25 × 40	2040	1.15	LGU2Z821MELA
	30 × 30	2040	1.15	LGU2Z821MELB
	35 × 25	2040	1.15	LGU2Z821MELC
1000	25 × 45	2300	1.27	LGU2Z102MELA
	30 × 35	2300	1.27	LGU2Z102MELB
	35 × 30	2300	1.27	LGU2Z102MELC
1200	25 × 50	2550	1.39	LGU2Z122MELA
	30 × 40	2550	1.39	LGU2Z122MELB
	35 × 30	2550	1.39	LGU2Z122MELC
1500	30 × 45	2900	1.55	LGU2Z152MELB
	35 × 35	2900	1.55	LGU2Z152MELC
1800	35 × 45	3300	1.70	LGU2Z182MELC
2200	35 × 50	3650	1.88	LGU2Z222MELC

200V (2D)				
Cap.(μF)	Size φD×L(mm)	Rated ripple (mArms)	Leakage Current (mA)	Code
220	20 × 25	1000	0.62	LGU2D221MELY
270	20 × 30	1100	0.69	LGU2D271MELY
	22 × 25	1100	0.69	LGU2D271MELZ
330	20 × 35	1200	0.77	LGU2D331MELY
	22 × 30	1250	0.77	LGU2D331MELZ
	25 × 25	1250	0.77	LGU2D331MELA
390	20 × 40	1310	0.83	LGU2D391MELY
	22 × 30	1350	0.83	LGU2D391MELZ
	25 × 25	1350	0.83	LGU2D391MELA
470	20 × 45	1450	0.91	LGU2D471MELY
	22 × 35	1500	0.91	LGU2D471MELZ
	25 × 30	1500	0.91	LGU2D471MELA
	30 × 25	1500	0.91	LGU2D471MELB
560	20 × 50	1580	1.00	LGU2D561MELY
	22 × 40	1670	1.00	LGU2D561MELZ
	25 × 30	1670	1.00	LGU2D561MELA
	30 × 25	1670	1.00	LGU2D561MELB
680	22 × 45	1780	1.10	LGU2D681MELZ
	25 × 35	1780	1.10	LGU2D681MELA
	30 × 30	1780	1.10	LGU2D681MELB
	35 × 25	1780	1.10	LGU2D681MELC
820	25 × 45	2040	1.21	LGU2D821MELA
	30 × 30	2040	1.21	LGU2D821MELB
	35 × 25	2040	1.21	LGU2D821MELC
1000	25 × 50	2300	1.34	LGU2D102MELA
	30 × 35	2300	1.34	LGU2D102MELB
	35 × 30	2300	1.34	LGU2D102MELC
1200	30 × 40	2650	1.46	LGU2D122MELB
	35 × 35	2650	1.46	LGU2D122MELC
1500	30 × 50	3080	1.64	LGU2D152MELB
	35 × 40	3080	1.64	LGU2D152MELC
1800	35 × 45	3480	1.80	LGU2D182MELC
2200	35 × 50	3780	1.98	LGU2D222MELC

220V (2P)				
Cap.(μF)	Size φD×L(mm)	Rated ripple (mArms)	Leakage Current (mA)	Code
180	20 × 25	900	0.59	LGU2P181MELY
220	20 × 30	1000	0.66	LGU2P221MELY
	22 × 25	1000	0.66	LGU2P221MELZ
270	20 × 35	1150	0.73	LGU2P271MELY
	22 × 30	1150	0.73	LGU2P271MELZ
330	20 × 40	1250	0.80	LGU2P331MELY
	22 × 35	1250	0.80	LGU2P331MELZ
	25 × 25	1250	0.80	LGU2P331MELA
390	20 × 45	1400	0.87	LGU2P391MELY
	22 × 35	1400	0.87	LGU2P391MELZ
	25 × 30	1400	0.87	LGU2P391MELA
470	20 × 50	1450	0.96	LGU2P471MELY
	22 × 40	1450	0.96	LGU2P471MELZ
	25 × 35	1450	0.96	LGU2P471MELA
	30 × 25	1450	0.96	LGU2P471MELB
560	22 × 45	1700	1.05	LGU2P561MELZ
	25 × 40	1700	1.05	LGU2P561MELA
	30 × 30	1700	1.05	LGU2P561MELB
680	25 × 45	1780	1.16	LGU2P681MELA
	30 × 35	1780	1.16	LGU2P681MELB
	35 × 25	1780	1.16	LGU2P681MELC
820	25 × 50	2100	1.27	LGU2P821MELA
	30 × 40	2100	1.27	LGU2P821MELB
	35 × 30	2100	1.27	LGU2P821MELC
1000	30 × 45	2400	1.40	LGU2P102MELB
	35 × 35	2400	1.40	LGU2P102MELC
1200	30 × 50	2600	1.54	LGU2P122MELB
	35 × 40	2600	1.54	LGU2P122MELC
1500	35 × 45	3000	1.72	LGU2P152MELC

250V (2E)				
Cap.(μF)	Size φD×L(mm)	Rated ripple (mArms)	Leakage Current (mA)	Code
150	20 × 25	790	0.58	LGU2E151MELY
180	20 × 30	900	0.63	LGU2E181MELY
220	20 × 30	1000	0.70	LGU2E221MELY
	22 × 25	1000	0.70	LGU2E221MELZ
270	20 × 35	1100	0.77	LGU2E271MELY
	22 × 35	1180	0.77	LGU2E271MELZ
	25 × 25	1180	0.77	LGU2E271MELA
330	20 × 40	1200	0.86	LGU2E331MELY
	22 × 40	1300	0.86	LGU2E331MELZ
	25 × 30	1300	0.86	LGU2E331MELA
	30 × 25	1300	0.86	LGU2E331MELB
	20 × 50	1450	0.93	LGU2E391MELY
390	22 × 45	1490	0.93	LGU2E391MELZ
	25 × 35	1490	0.93	LGU2E391MELA
	30 × 25	1490	0.93	LGU2E391MELB
	22 × 50	1650	1.02	LGU2E471MELZ
470	25 × 40	1650	1.02	LGU2E471MELA
	30 × 30	1650	1.02	LGU2E471MELB
	35 × 25	1650	1.02	LGU2E471MELC
	25 × 45	1800	1.12	LGU2E561MELA
560	30 × 35	1800	1.12	LGU2E561MELB
	35 × 25	1800	1.12	LGU2E561MELC
	25 × 50	2000	1.23	LGU2E681MELA
680	30 × 40	2000	1.23	LGU2E681MELB
	35 × 30	2000	1.23	LGU2E681MELC
	820	30 × 45	2300	1.35
35 × 35		2300	1.35	LGU2E821MELC
1000	30 × 50	2470	1.50	LGU2E102MELB
	35 × 40	2470	1.50	LGU2E102MELC
1200	35 × 45	2600	1.64	LGU2E122MELC
1500	35 × 50	3000	1.83	LGU2E152MELC

Rated ripple current (mArms) at 105°C 120Hz



## ■ Dimensions

315V (2F)				
Cap. (μF)	Size φD×L (mm)	Rated ripple (mArms)	Leakage Current (mA)	Code
82	20 × 25	640	0.48	LGU2F820MELY
100	20 × 30	690	0.53	LGU2F101MELY
120	20 × 30	750	0.58	LGU2F121MELY
	22 × 25	750	0.58	LGU2F121MELZ
150	20 × 35	820	0.65	LGU2F151MELY
	22 × 30	820	0.65	LGU2F151MELZ
	25 × 25	820	0.65	LGU2F151MELA
180	20 × 40	900	0.71	LGU2F181MELY
	22 × 35	920	0.71	LGU2F181MELZ
	25 × 25	920	0.71	LGU2F181MELA
220	20 × 50	1000	0.78	LGU2F221MELY
	22 × 40	1040	0.78	LGU2F221MELZ
	25 × 30	1040	0.78	LGU2F221MELA
	30 × 25	1040	0.78	LGU2F221MELB
270	22 × 45	1160	0.87	LGU2F271MELZ
	25 × 35	1160	0.87	LGU2F271MELA
	30 × 25	1160	0.87	LGU2F271MELB
330	22 × 50	1330	0.96	LGU2F331MELZ
	25 × 40	1330	0.96	LGU2F331MELA
	30 × 30	1330	0.96	LGU2F331MELB
390	35 × 25	1330	0.96	LGU2F331MELC
	25 × 45	1470	1.05	LGU2F391MELA
	30 × 35	1470	1.05	LGU2F391MELB
470	35 × 30	1470	1.05	LGU2F391MELC
	25 × 50	1700	1.15	LGU2F471MELA
	30 × 40	1700	1.15	LGU2F471MELB
560	35 × 30	1700	1.15	LGU2F471MELC
	30 × 45	2050	1.26	LGU2F561MELB
	35 × 35	2050	1.26	LGU2F561MELC
680	30 × 50	2170	1.38	LGU2F681MELB
	35 × 40	2170	1.38	LGU2F681MELC
820	35 × 45	2200	1.52	LGU2F821MELC

400V (2G)				
Cap. (μF)	Size φD×L (mm)	Rated ripple (mArms)	Leakage Current (mA)	Code
56	20 × 25	510	0.44	LGU2G560MELY
68	20 × 30	560	0.49	LGU2G680MELY
82	20 × 30	640	0.54	LGU2G820MELY
	22 × 25	640	0.54	LGU2G820MELZ
100	20 × 35	700	0.60	LGU2G101MELY
	22 × 30	700	0.60	LGU2G101MELZ
	25 × 25	700	0.60	LGU2G101MELA
120	20 × 40	750	0.65	LGU2G121MELY
	22 × 35	750	0.65	LGU2G121MELZ
	25 × 25	750	0.65	LGU2G121MELA
150	20 × 45	830	0.73	LGU2G151MELY
	22 × 40	880	0.73	LGU2G151MELZ
	25 × 30	880	0.73	LGU2G151MELA
	30 × 25	880	0.73	LGU2G151MELB
180	22 × 45	980	0.80	LGU2G181MELZ
	25 × 35	980	0.80	LGU2G181MELA
	30 × 30	980	0.80	LGU2G181MELB
	35 × 25	980	0.80	LGU2G181MELC
220	22 × 50	1100	0.88	LGU2G221MELZ
	25 × 40	1100	0.88	LGU2G221MELA
	30 × 30	1100	0.88	LGU2G221MELB
	35 × 25	1100	0.88	LGU2G221MELC
270	25 × 45	1220	0.98	LGU2G271MELA
	30 × 35	1220	0.98	LGU2G271MELB
	35 × 30	1220	0.98	LGU2G271MELC
330	25 × 50	1440	1.08	LGU2G331MELA
	30 × 40	1440	1.08	LGU2G331MELB
	35 × 30	1440	1.08	LGU2G331MELC
390	30 × 45	1600	1.18	LGU2G391MELB
	35 × 35	1600	1.18	LGU2G391MELC
470	30 × 50	1900	1.30	LGU2G471MELB
	35 × 40	1900	1.30	LGU2G471MELC
560	35 × 45	2120	1.41	LGU2G561MELC

420V (W6)				
Cap. (μF)	Size φD×L (mm)	Rated ripple (mArms)	Leakage Current (mA)	Code
56	20 × 25	510	0.46	LGUW6560MELY
68	20 × 30	560	0.50	LGUW6680MELY
82	20 × 35	640	0.55	LGUW6820MELY
	22 × 25	640	0.55	LGUW6820MELZ
100	20 × 35	700	0.61	LGUW6101MELY
	22 × 30	700	0.61	LGUW6101MELZ
	25 × 25	700	0.61	LGUW6101MELA
120	20 × 40	750	0.67	LGUW6121MELY
	22 × 35	750	0.67	LGUW6121MELZ
	25 × 30	750	0.67	LGUW6121MELA
150	20 × 50	880	0.75	LGUW6151MELY
	22 × 40	880	0.75	LGUW6151MELZ
	25 × 35	880	0.75	LGUW6151MELA
	30 × 25	880	0.75	LGUW6151MELB
180	22 × 45	950	0.82	LGUW6181MELZ
	25 × 35	950	0.82	LGUW6181MELA
	30 × 30	950	0.82	LGUW6181MELB
220	22 × 50	1100	0.91	LGUW6221MELZ
	25 × 45	1100	0.91	LGUW6221MELA
	30 × 35	1100	0.91	LGUW6221MELB
	35 × 25	1100	0.91	LGUW6221MELC
270	25 × 50	1220	1.01	LGUW6271MELA
	30 × 40	1220	1.01	LGUW6271MELB
	35 × 30	1220	1.01	LGUW6271MELC
330	30 × 45	1450	1.11	LGUW6331MELB
	35 × 35	1450	1.11	LGUW6331MELC
390	30 × 50	1550	1.21	LGUW6391MELB
	35 × 40	1550	1.21	LGUW6391MELC
470	35 × 45	1900	1.33	LGUW6471MELC
560	35 × 50	2150	1.45	LGUW6561MELC

450V (2W)				
Cap. (μF)	Size φD×L (mm)	Rated ripple (mArms)	Leakage Current (mA)	Code
47	20 × 25	390	0.43	LGU2W470MELY
56	20 × 30	510	0.47	LGU2W560MELY
68	20 × 35	560	0.52	LGU2W680MELY
	20 × 35	640	0.57	LGU2W820MELY
82	22 × 30	640	0.57	LGU2W820MELZ
	25 × 25	640	0.57	LGU2W820MELA
	20 × 45	690	0.63	LGU2W101MELY
100	22 × 35	690	0.63	LGU2W101MELZ
	25 × 30	690	0.63	LGU2W101MELA
	20 × 50	750	0.69	LGU2W121MELY
120	22 × 40	800	0.69	LGU2W121MELZ
	25 × 30	800	0.69	LGU2W121MELA
	30 × 25	800	0.69	LGU2W121MELB
	22 × 45	880	0.77	LGU2W151MELZ
150	25 × 35	880	0.77	LGU2W151MELA
	30 × 30	880	0.77	LGU2W151MELB
	22 × 50	1000	0.85	LGU2W181MELZ
180	25 × 40	1000	0.85	LGU2W181MELA
	30 × 30	1000	0.85	LGU2W181MELB
	25 × 45	1120	0.94	LGU2W221MELA
220	30 × 35	1120	0.94	LGU2W221MELB
	35 × 30	1120	0.94	LGU2W221MELC
270	30 × 40	1280	1.04	LGU2W271MELB
	35 × 35	1280	1.04	LGU2W271MELC
330	30 × 50	1450	1.15	LGU2W331MELB
	35 × 40	1450	1.15	LGU2W331MELC
390	35 × 40	1500	1.25	LGU2W391MELC
470	35 × 50	1850	1.37	LGU2W471MELC

Rated ripple current (mArms) at 105°C 120Hz

# ALUMINUM ELECTROLYTIC CAPACITORS

# LGN

Snap-in Terminal Type, 105°C Smaller-Sized



- Withstanding 3000 hours application of rated ripple current at 105°C.
- One rank smaller case sized than LGU.
- Addition of 600V rated voltage.
- Compliant to the RoHS directive (2011/65/EU,(EU)2015/863).

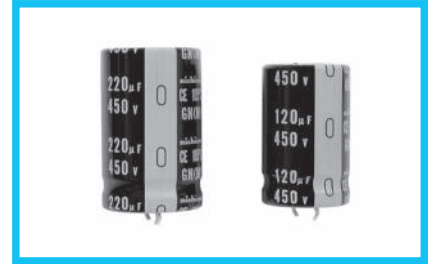

## Specifications

Item	Performance Characteristics								
Category Temperature Range	- 40 to +105°C (160 to 250V) , - 25 to +105°C (350 to 600V)								
Rated Voltage Range	160 to 600V								
Rated Capacitance Range	56 to 3300µF								
Capacitance Tolerance	±20% at 120Hz, 20°C								
Leakage Current	$I \leq 3\sqrt{CV}$ (µA) (After 5 minutes' application of rated voltage at 20°C) [C : Rated Capacitance (µF) V : Voltage (V)]								
Tangent of loss angle (tan δ)	Rated voltage (V)	160 to 420      450 to 600	Measurement frequency : 120Hz at 20°C						
	tan δ (MAX.)	0.15      0.20							
Stability at Low Temperature	Rated voltage (V)	160 to 250      350 to 600	Measurement frequency : 120Hz						
	Impedance ratio ZT/Z20 (MAX.)	Z - 25°C/Z+20°C      4      8							
Endurance	The specifications listed at right shall be met when the capacitors are restored to 20°C after D.C. bias plus rated ripple current is applied for 3000 hours at 105°C, the peak voltage shall not exceed the rated voltage. (2000 hours at 105°C for the parts rated at 600V)		<table border="1"> <tr> <td>Capacitance change</td> <td>Within ±20% of the initial capacitance value</td> </tr> <tr> <td>tan δ</td> <td>200% or less than the initial specified value</td> </tr> <tr> <td>Leakage current</td> <td>Less than or equal to the initial specified value</td> </tr> </table>	Capacitance change	Within ±20% of the initial capacitance value	tan δ	200% or less than the initial specified value	Leakage current	Less than or equal to the initial specified value
Capacitance change	Within ±20% of the initial capacitance value								
tan δ	200% or less than the initial specified value								
Leakage current	Less than or equal to the initial specified value								
Shelf Life	After storing the capacitors under no load at 105°C for 1000hours and then performing voltage treatment based on JIS C 5101-4 clause 4.1 at 20°C, they shall meet the characteristic requirements listed at right.		<table border="1"> <tr> <td>Capacitance change</td> <td>Within ±20% of the initial capacitance value</td> </tr> <tr> <td>tan δ</td> <td>200% or less than the initial specified value</td> </tr> <tr> <td>Leakage current</td> <td>Less than or equal to the initial specified value</td> </tr> </table>	Capacitance change	Within ±20% of the initial capacitance value	tan δ	200% or less than the initial specified value	Leakage current	Less than or equal to the initial specified value
Capacitance change	Within ±20% of the initial capacitance value								
tan δ	200% or less than the initial specified value								
Leakage current	Less than or equal to the initial specified value								
Marking	Printed with white color letter on black sleeve.								

## Drawing

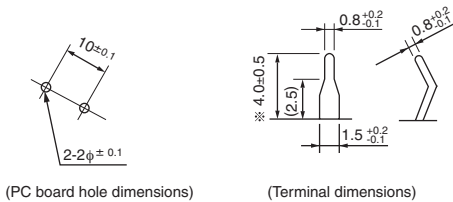
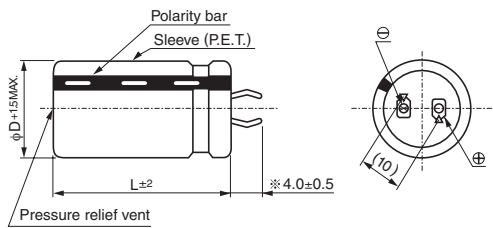

※ Other terminations available upon request.  
Please refer to the Guidelines for Aluminum Electrolytic Capacitors.

## Type numbering system (Example : 400V 180µF)

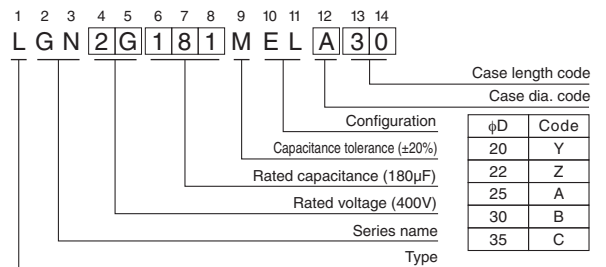

Minimum order quantity : 50pcs.

● Dimension table in next page.



## ■ Dimensions

160V (2C)				
Cap.(μF)	Size φD×L(mm)	Rated ripple (mArms)	Leakage Current (mA)	Code
330	20 × 25	1170	0.68	LGN2C331MELY25
390	20 × 25	1280	0.74	LGN2C391MELY25
470	20 × 30	1400	0.82	LGN2C471MELY30
	22 × 25	1400	0.82	LGN2C471MELZ25
560	20 × 35	1500	0.89	LGN2C561MELY35
	22 × 30	1500	0.89	LGN2C561MELZ30
680	20 × 40	1700	0.98	LGN2C681MELY40
	22 × 35	1700	0.98	LGN2C681MELZ35
	25 × 25	1700	0.98	LGN2C681MELA25
820	22 × 35	2000	1.08	LGN2C821MELZ35
	25 × 30	2000	1.08	LGN2C821MELA30
	30 × 25	2000	1.08	LGN2C821MELB25
1000	22 × 45	2200	1.20	LGN2C102MELZ45
	25 × 35	2200	1.20	LGN2C102MELA35
	30 × 25	2200	1.20	LGN2C102MELB25
1200	25 × 40	2300	1.31	LGN2C122MELA40
	30 × 30	2300	1.31	LGN2C122MELB30
	35 × 25	2300	1.31	LGN2C122MELC25
1500	25 × 45	2500	1.46	LGN2C152MELA45
	30 × 35	2500	1.46	LGN2C152MELB35
	35 × 30	2500	1.46	LGN2C152MELC30
1800	30 × 40	2700	1.60	LGN2C182MELB40
	35 × 35	2700	1.60	LGN2C182MELC35
2200	30 × 45	2900	1.77	LGN2C222MELB45
	35 × 35	2900	1.77	LGN2C222MELC35
2700	35 × 45	3100	1.97	LGN2C272MELC45
3300	35 × 50	3300	2.17	LGN2C332MELC50

180V (2Z)				
Cap.(μF)	Size φD×L(mm)	Rated ripple (mArms)	Leakage Current (mA)	Code
330	20 × 25	1200	0.73	LGN2Z331MELY25
390	20 × 30	1280	0.79	LGN2Z391MELY30
	22 × 25	1280	0.79	LGN2Z391MELZ25
470	20 × 35	1380	0.87	LGN2Z471MELY35
	22 × 30	1380	0.87	LGN2Z471MELZ30
560	20 × 40	1500	0.95	LGN2Z561MELY40
	22 × 30	1500	0.95	LGN2Z561MELZ30
	25 × 25	1500	0.95	LGN2Z561MELA25
680	20 × 45	1700	1.04	LGN2Z681MELY45
	22 × 35	1700	1.04	LGN2Z681MELZ35
	25 × 30	1700	1.04	LGN2Z681MELA30
820	22 × 40	2000	1.15	LGN2Z821MELZ40
	25 × 35	2000	1.15	LGN2Z821MELA35
	30 × 25	2000	1.15	LGN2Z821MELB25
1000	25 × 40	2200	1.27	LGN2Z102MELA40
	30 × 30	2200	1.27	LGN2Z102MELB30
	35 × 25	2200	1.27	LGN2Z102MELC25
1200	25 × 45	2300	1.39	LGN2Z122MELA45
	30 × 35	2300	1.39	LGN2Z122MELB35
	35 × 30	2300	1.39	LGN2Z122MELC30
1500	25 × 50	2500	1.55	LGN2Z152MELA50
	30 × 40	2500	1.55	LGN2Z152MELB40
	35 × 30	2500	1.55	LGN2Z152MELC30
1800	30 × 45	2700	1.70	LGN2Z182MELB45
	35 × 35	2700	1.70	LGN2Z182MELC35
	30 × 50	2900	1.88	LGN2Z222MELB50
2200	35 × 40	2900	1.88	LGN2Z222MELC40
	35 × 50	3100	2.09	LGN2Z272MELC50

200V (2D)				
Cap.(μF)	Size φD×L(mm)	Rated ripple (mArms)	Leakage Current (mA)	Code
270	20 × 25	990	0.69	LGN2D271MELY25
330	20 × 30	1200	0.77	LGN2D331MELY30
	22 × 25	1200	0.77	LGN2D331MELZ25
390	20 × 30	1340	0.83	LGN2D391MELY30
	22 × 25	1310	0.83	LGN2D391MELZ25
470	20 × 35	1480	0.91	LGN2D471MELY35
	22 × 30	1480	0.91	LGN2D471MELZ30
	25 × 25	1480	0.91	LGN2D471MELA25
560	20 × 40	1600	1.00	LGN2D561MELY40
	22 × 35	1600	1.00	LGN2D561MELZ35
680	22 × 40	1750	1.10	LGN2D681MELZ40
	25 × 30	1750	1.10	LGN2D681MELA35
	30 × 25	1750	1.10	LGN2D681MELB25
820	22 × 45	2040	1.21	LGN2D821MELZ45
	25 × 35	2040	1.21	LGN2D821MELA35
1000	22 × 50	2300	1.34	LGN2D102MELZ50
	25 × 45	2300	1.34	LGN2D102MELA45
	30 × 30	2300	1.34	LGN2D102MELB30
	35 × 25	2300	1.34	LGN2D102MELC25
1200	25 × 50	2650	1.46	LGN2D122MELA50
	30 × 35	2650	1.46	LGN2D122MELB35
	35 × 30	2650	1.46	LGN2D122MELC30
1500	30 × 40	2800	1.64	LGN2D152MELB40
	35 × 35	2800	1.64	LGN2D152MELC35
1800	30 × 50	3080	1.80	LGN2D182MELB50
	35 × 40	3080	1.80	LGN2D182MELC40
2200	35 × 45	3480	1.98	LGN2D222MELC45

220V (2P)				
Cap.(μF)	Size φD×L(mm)	Rated ripple (mArms)	Leakage Current (mA)	Code
220	20 × 25	980	0.66	LGN2P221MELY25
270	20 × 30	1080	0.73	LGN2P271MELY30
	22 × 25	1080	0.73	LGN2P271MELZ25
330	20 × 35	1260	0.80	LGN2P331MELY35
	22 × 25	1260	0.80	LGN2P331MELZ25
390	20 × 35	1340	0.87	LGN2P391MELY35
	22 × 30	1340	0.87	LGN2P391MELZ30
	25 × 25	1340	0.87	LGN2P391MELA25
470	20 × 45	1480	0.96	LGN2P471MELY45
	22 × 35	1480	0.96	LGN2P471MELZ35
560	22 × 40	1610	1.05	LGN2P561MELZ40
	25 × 35	1610	1.05	LGN2P561MELA35
	30 × 25	1610	1.05	LGN2P561MELB25
680	22 × 45	1780	1.16	LGN2P681MELZ45
	25 × 35	1780	1.16	LGN2P681MELA35
	30 × 30	1780	1.16	LGN2P681MELB30
820	22 × 50	1930	1.27	LGN2P821MELZ50
	25 × 40	1930	1.27	LGN2P821MELA40
	30 × 35	1930	1.27	LGN2P821MELB35
	35 × 25	1930	1.27	LGN2P821MELC25
1000	25 × 50	2330	1.40	LGN2P102MELA50
	30 × 35	2330	1.40	LGN2P102MELB35
	35 × 30	2330	1.40	LGN2P102MELC30
1200	30 × 40	2500	1.54	LGN2P122MELB40
	35 × 35	2500	1.54	LGN2P122MELC35
1500	30 × 50	2760	1.72	LGN2P152MELB50
	35 × 40	2760	1.72	LGN2P152MELC40
1800	35 × 50	3110	1.88	LGN2P182MELC50

Rated ripple current (mArms) at 105°C 120Hz



## ■ Dimensions

250V (2E)				
Cap.(μF)	Size φD×L(mm)	Rated ripple (mArms)	Leakage Current (mA)	Code
220	22 × 25	1000	0.70	LGN2E221MELZ25
270	22 × 25	1100	0.77	LGN2E271MELZ25
330	20 × 35	1200	0.86	LGN2E331MELY35
	22 × 30	1200	0.86	LGN2E331MELZ30
	25 × 25	1200	0.86	LGN2E331MELA25
390	20 × 40	1300	0.93	LGN2E391MELY40
	22 × 35	1300	0.93	LGN2E391MELZ35
	25 × 30	1300	0.93	LGN2E391MELA30
470	22 × 40	1400	1.02	LGN2E471MELZ40
	25 × 35	1400	1.02	LGN2E471MELA35
	30 × 25	1400	1.02	LGN2E471MELB25
560	22 × 45	1500	1.12	LGN2E561MELZ45
	25 × 35	1500	1.12	LGN2E561MELA35
	30 × 30	1500	1.12	LGN2E561MELB30
680	22 × 50	1700	1.23	LGN2E681MELZ50
	25 × 40	1700	1.23	LGN2E681MELA40
	30 × 30	1700	1.23	LGN2E681MELB30
	35 × 25	1700	1.23	LGN2E681MELC25
820	25 × 45	2000	1.35	LGN2E821MELA45
	30 × 35	2000	1.35	LGN2E821MELB35
	35 × 30	2000	1.35	LGN2E821MELC30
1000	30 × 40	2200	1.50	LGN2E102MELB40
	35 × 35	2200	1.50	LGN2E102MELC35
1200	30 × 45	2300	1.64	LGN2E122MELB45
	35 × 40	2300	1.64	LGN2E122MELC40
1500	35 × 45	2500	1.83	LGN2E152MELC45
1800	35 × 50	2700	2.01	LGN2E182MELC50

350V (2V)				
Cap.(μF)	Size φD×L(mm)	Rated ripple (mArms)	Leakage Current (mA)	Code
120	22 × 25	750	0.61	LGN2V121MELZ25
150	22 × 30	820	0.68	LGN2V151MELZ30
180	22 × 30	900	0.75	LGN2V181MELZ30
	25 × 25	900	0.75	LGN2V181MELA25
220	22 × 35	1000	0.83	LGN2V221MELZ35
	25 × 30	1000	0.83	LGN2V221MELA30
270	22 × 40	1100	0.92	LGN2V271MELZ40
	25 × 35	1100	0.92	LGN2V271MELA35
	30 × 25	1100	0.92	LGN2V271MELB25
330	22 × 45	1200	1.01	LGN2V331MELZ45
	25 × 40	1200	1.01	LGN2V331MELA40
	30 × 30	1200	1.01	LGN2V331MELB30
390	25 × 45	1300	1.10	LGN2V391MELA45
	30 × 35	1300	1.10	LGN2V391MELB35
470	25 × 50	1400	1.21	LGN2V471MELA50
	30 × 40	1400	1.21	LGN2V471MELB40
	35 × 30	1400	1.21	LGN2V471MELC30
560	30 × 45	1500	1.32	LGN2V561MELB45
	35 × 35	1500	1.32	LGN2V561MELC35
680	30 × 50	1700	1.46	LGN2V681MELB50
	35 × 40	1700	1.46	LGN2V681MELC40
820	35 × 45	1900	1.60	LGN2V821MELC45

400V (2G)				
Cap.(μF)	Size φD×L(mm)	Rated ripple (mArms)	Leakage Current (mA)	Code
68	20 × 25	490	0.49	LGN2G680MELY25
82	20 × 30	640	0.54	LGN2G820MELY30
100	20 × 30	680	0.60	LGN2G101MELY30
	22 × 25	680	0.60	LGN2G101MELZ25
120	20 × 35	730	0.65	LGN2G121MELY35
	22 × 30	730	0.65	LGN2G121MELZ30
150	20 × 40	850	0.73	LGN2G151MELY40
	22 × 35	850	0.73	LGN2G151MELZ35
180	22 × 35	950	0.80	LGN2G181MELZ35
	25 × 30	950	0.80	LGN2G181MELA30
	30 × 25	950	0.80	LGN2G181MELB25
220	22 × 45	1100	0.88	LGN2G221MELZ45
	25 × 35	1100	0.88	LGN2G221MELA35
	30 × 25	1100	0.88	LGN2G221MELB25
270	22 × 50	1220	0.98	LGN2G271MELZ50
	25 × 40	1220	0.98	LGN2G271MELA40
	30 × 30	1220	0.98	LGN2G271MELB30
	35 × 25	1220	0.98	LGN2G271MELC25
330	25 × 45	1440	1.08	LGN2G331MELA45
	30 × 35	1440	1.08	LGN2G331MELB35
390	25 × 50	1550	1.18	LGN2G391MELA50
	30 × 40	1550	1.18	LGN2G391MELB40
470	30 × 45	1680	1.30	LGN2G471MELB45
	35 × 35	1680	1.30	LGN2G471MELC35
560	30 × 50	1900	1.41	LGN2G561MELB50
	35 × 40	1900	1.41	LGN2G561MELC40
680	35 × 45	2120	1.56	LGN2G681MELC45

420V (W6)				
Cap.(μF)	Size φD×L(mm)	Rated ripple (mArms)	Leakage Current (mA)	Code
68	20 × 25	500	0.50	LGNW6680MELY25
82	20 × 25	640	0.55	LGNW6820MELY25
100	20 × 30	660	0.61	LGNW6101MELY30
	22 × 25	660	0.61	LGNW6101MELZ25
120	20 × 35	810	0.67	LGNW6121MELY35
	22 × 30	810	0.67	LGNW6121MELZ30
150	25 × 25	810	0.67	LGNW6121MELA25
	20 × 40	840	0.75	LGNW6151MELY40
	22 × 35	840	0.75	LGNW6151MELZ35
180	25 × 30	840	0.75	LGNW6151MELA30
	20 × 45	910	0.82	LGNW6181MELY45
	22 × 40	910	0.82	LGNW6181MELZ40
220	25 × 30	910	0.82	LGNW6181MELA30
	30 × 25	910	0.82	LGNW6181MELB25
	22 × 45	1050	0.91	LGNW6221MELZ45
270	25 × 35	1050	0.91	LGNW6221MELA35
	30 × 30	1050	0.91	LGNW6221MELB30
	25 × 40	1250	1.01	LGNW6271MELA40
330	30 × 30	1250	1.01	LGNW6271MELB30
	35 × 25	1250	1.01	LGNW6271MELC25
	25 × 50	1420	1.11	LGNW6331MELA50
390	30 × 35	1420	1.11	LGNW6331MELB35
	35 × 30	1420	1.11	LGNW6331MELC30
470	30 × 40	1610	1.21	LGNW6391MELB40
	35 × 35	1610	1.21	LGNW6391MELC35
560	30 × 45	1860	1.33	LGNW6471MELB45
	35 × 40	1860	1.33	LGNW6471MELC40
680	35 × 45	2100	1.45	LGNW6561MELC45
820	35 × 50	2200	1.60	LGNW6681MELC50

Rated ripple current (mArms) at 105°C 120Hz



## LGN

### ■ Dimensions

450V (2W)				
Cap.( $\mu$ F)	Size $\phi$ D $\times$ L(mm)	Rated ripple (mArms)	Leakage Current (mA)	Code
56	20 $\times$ 25	440	0.47	LGN2W560MELY25
68	20 $\times$ 25	500	0.52	LGN2W680MELY25
82	20 $\times$ 30	640	0.57	LGN2W820MELY30
	22 $\times$ 25	640	0.57	LGN2W820MELZ25
100	20 $\times$ 35	690	0.63	LGN2W101MELY35
	22 $\times$ 30	690	0.63	LGN2W101MELZ30
	25 $\times$ 25	690	0.63	LGN2W101MELA25
120	22 $\times$ 35	720	0.69	LGN2W121MELZ35
	25 $\times$ 30	720	0.69	LGN2W121MELA30
150	20 $\times$ 45	790	0.77	LGN2W151MELY45
	22 $\times$ 40	790	0.77	LGN2W151MELZ40
	25 $\times$ 30	790	0.77	LGN2W151MELA30
	30 $\times$ 25	790	0.77	LGN2W151MELB25
180	22 $\times$ 45	870	0.85	LGN2W181MELZ45
	25 $\times$ 35	870	0.85	LGN2W181MELA35
	30 $\times$ 30	870	0.85	LGN2W181MELB30
220	25 $\times$ 40	1050	0.94	LGN2W221MELA40
	30 $\times$ 30	1050	0.94	LGN2W221MELB30
	35 $\times$ 25	1050	0.94	LGN2W221MELC25
270	25 $\times$ 50	1230	1.04	LGN2W271MELA50
	30 $\times$ 35	1230	1.04	LGN2W271MELB35
	35 $\times$ 30	1230	1.04	LGN2W271MELC30
330	30 $\times$ 40	1380	1.15	LGN2W331MELB40
	35 $\times$ 35	1380	1.15	LGN2W331MELC35
390	30 $\times$ 50	1610	1.25	LGN2W391MELB50
	35 $\times$ 40	1610	1.25	LGN2W391MELC40
470	35 $\times$ 45	1780	1.37	LGN2W471MELC45
560	35 $\times$ 50	1990	1.50	LGN2W561MELC50

500V (2H)				
Cap.( $\mu$ F)	Size $\phi$ D $\times$ L(mm)	Rated ripple (mArms)	Leakage Current (mA)	Code
56	22 $\times$ 25	470	0.50	LGN2H560MELZ25
68	22 $\times$ 30	520	0.55	LGN2H680MELZ30
	25 $\times$ 25	520	0.55	LGN2H680MELA25
82	22 $\times$ 35	590	0.60	LGN2H820MELZ35
100	22 $\times$ 40	650	0.67	LGN2H101MELZ40
	25 $\times$ 30	650	0.67	LGN2H101MELA30
	30 $\times$ 25	650	0.67	LGN2H101MELB25
	22 $\times$ 45	680	0.73	LGN2H121MELZ45
120	25 $\times$ 35	680	0.73	LGN2H121MELA35
	30 $\times$ 30	680	0.73	LGN2H121MELB30
	22 $\times$ 50	750	0.82	LGN2H151MELZ50
150	25 $\times$ 45	750	0.82	LGN2H151MELA45
	35 $\times$ 25	750	0.82	LGN2H151MELC25
	25 $\times$ 50	900	0.90	LGN2H181MELA50
	30 $\times$ 35	900	0.90	LGN2H181MELB35
180	35 $\times$ 30	900	0.90	LGN2H181MELC30
	30 $\times$ 45	1020	0.99	LGN2H221MELB45
	35 $\times$ 35	1020	0.99	LGN2H221MELC35
270	30 $\times$ 50	1120	1.10	LGN2H271MELB50
	35 $\times$ 40	1120	1.10	LGN2H271MELC40
330	35 $\times$ 45	1250	1.21	LGN2H331MELC45
390	35 $\times$ 50	1300	1.32	LGN2H391MELC50

### ■ Dimensions

600V (2X)				
Cap.( $\mu$ F)	Size $\phi$ D $\times$ L(mm)	Rated ripple (mArms)	Leakage Current (mA)	Code
56	30 $\times$ 25	500	0.55	LGN2X560MELB25
68	30 $\times$ 30	560	0.61	LGN2X680MELB30
82	30 $\times$ 35	610	0.67	LGN2X820MELB35
	35 $\times$ 25	610	0.67	LGN2X820MELC25
100	30 $\times$ 40	670	0.73	LGN2X101MELB40
	35 $\times$ 30	670	0.73	LGN2X101MELC30
120	30 $\times$ 45	740	0.80	LGN2X121MELB45
	35 $\times$ 35	740	0.80	LGN2X121MELC35
150	30 $\times$ 50	830	0.90	LGN2X151MELB50
	35 $\times$ 40	830	0.90	LGN2X151MELC40
180	35 $\times$ 45	900	0.99	LGN2X181MELC45
220	35 $\times$ 50	1000	1.09	LGN2X221MELC50

Rated ripple current (mArms) at 105°C 120Hz

### ● Frequency coefficient of rated ripple current

Frequency (Hz)	50	60	120	300	1k	10k	50k or more
coeff. 160 to 250V	0.81	0.85	1.00	1.17	1.32	1.45	1.50
350 to 600V	0.77	0.82	1.00	1.16	1.30	1.41	1.43

# LGG

Snap-in Terminal Type, 105°C Ultra-Smaller-Sized



- One rank smaller case sized than LGN.
- Suited for equipment down sizing.
- Compliant to the RoHS directive (2011/65/EU,(EU)2015/863).

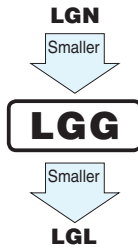

## Specifications

Item	Performance Characteristics				
Category Temperature Range	- 40 to +105°C (160 to 250V) , - 25 to +105°C (400 to 450V)				
Rated Voltage Range	160 to 450V				
Rated Capacitance Range	100 to 3300μF				
Capacitance Tolerance	±20% at 120Hz, 20°C				
Leakage Current	$I \leq 3\sqrt{CV}$ (μA) (After 5 minutes' application of rated voltage) [C : Rated Capacitance (μF) V : Voltage (V)]				
Tangent of loss angle (tan δ)	Rated voltage (V)	160 to 420	450	Measurement frequency : 120Hz at 20°C	
	tan δ (MAX.)	0.15	0.20		
Stability at Low Temperature	Rated voltage (V)		160 to 250	400 to 450	Measurement frequency : 120Hz
	Impedance ratio ZT/Z20 (MAX.)	Z - 25°C/Z+20°C	4	8	
Endurance	The specifications listed at right shall be met when the capacitors are restored to 20°C after D.C. bias plus rated ripple current is applied for 2000 hours at 105°C, the peak voltage shall not exceed the rated voltage.			Capacitance change	Within ±20% of the initial capacitance value
				tan δ	200% or less than the initial specified value
				Leakage current	Less than or equal to the initial specified value
Shelf Life	After storing the capacitors under no load at 105°C for 1000 hours and then performing voltage treatment based on JIS C 5101-4 clause 4.1 at 20°C, they shall meet the characteristic requirements listed at right.			Capacitance change	Within ±20% of the initial capacitance value
				tan δ	200% or less than the initial specified value
				Leakage current	Less than or equal to the initial specified value
Marking	Printed with white color letter on black sleeve.				

## Drawing

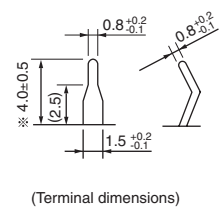
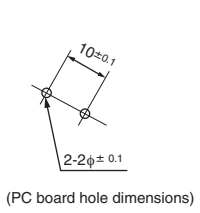
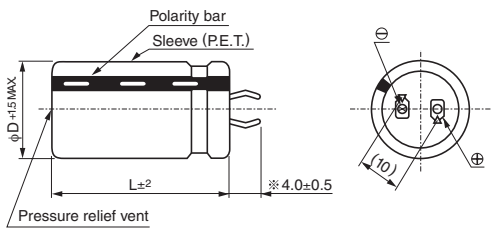

\* Other terminations available upon request.  
Please refer to the Guidelines for Aluminum Electrolytic Capacitors.

## Type numbering system (Example : 400V 180μF)

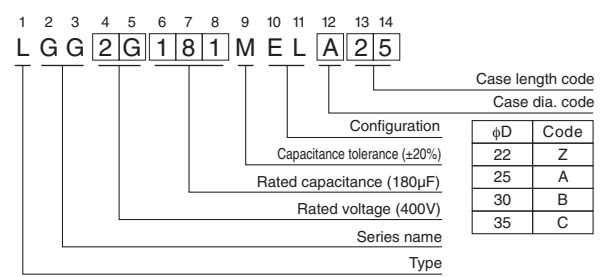

Minimum order quantity : 50pcs.

● Dimension table in next page.



## ■ Dimensions

160V (2C)				
Cap. (μF)	Size φD x L(mm)	Rated ripple (mArms)	Leakage Current (mA)	Code
560	22 x 25	1400	0.89	LGG2C561MELZ25
680	22 x 30	1500	0.98	LGG2C681MELZ30
	25 x 25	1700	0.98	LGG2C681MELA25
820	22 x 35	2000	1.08	LGG2C821MELZ35
	25 x 30	2000	1.08	LGG2C821MELA30
1000	22 x 40	2100	1.20	LGG2C102MELZ40
	25 x 35	2200	1.20	LGG2C102MELA35
	30 x 25	2200	1.20	LGG2C102MELB25
1200	25 x 40	2300	1.31	LGG2C122MELA40
	30 x 30	2300	1.31	LGG2C122MELB30
	35 x 25	2300	1.31	LGG2C122MELC25
1500	25 x 45	2500	1.46	LGG2C152MELA45
	30 x 35	2500	1.46	LGG2C152MELB35
	35 x 30	2500	1.46	LGG2C152MELC30
1800	30 x 40	2700	1.60	LGG2C182MELB40
	35 x 30	2550	1.60	LGG2C182MELC30
2200	30 x 45	2900	1.77	LGG2C222MELB45
	35 x 35	2900	1.77	LGG2C222MELC35
2700	35 x 40	3000	1.97	LGG2C272MELC40
3300	35 x 45	3100	2.17	LGG2C332MELC45

180V (2Z)				
Cap. (μF)	Size φD x L(mm)	Rated ripple (mArms)	Leakage Current (mA)	Code
470	22 x 25	1300	0.87	LGG2Z471MELZ25
560	22 x 30	1500	0.95	LGG2Z561MELZ30
680	22 x 35	1700	1.04	LGG2Z681MELZ35
	25 x 30	1700	1.04	LGG2Z681MELA30
820	22 x 40	2000	1.15	LGG2Z821MELZ40
	25 x 35	2000	1.15	LGG2Z821MELA35
	30 x 25	2000	1.15	LGG2Z821MELB25
1000	22 x 45	2100	1.27	LGG2Z102MELZ45
	25 x 35	2050	1.27	LGG2Z102MELA35
	30 x 30	2200	1.27	LGG2Z102MELB30
1200	22 x 50	2150	1.39	LGG2Z122MELZ50
	25 x 40	2150	1.39	LGG2Z122MELA40
	30 x 35	2300	1.39	LGG2Z122MELB35
	35 x 25	2150	1.39	LGG2Z122MELC25
1500	25 x 50	2400	1.55	LGG2Z152MELA50
	30 x 40	2500	1.55	LGG2Z152MELB40
1800	35 x 30	2350	1.55	LGG2Z152MELC30
	30 x 45	2700	1.70	LGG2Z182MELB45
2200	35 x 35	2700	1.70	LGG2Z182MELC35
	30 x 50	2900	1.88	LGG2Z222MELB50
2700	35 x 40	2900	1.88	LGG2Z222MELC40
	35 x 45	3000	2.09	LGG2Z272MELC45
3300	35 x 50	3100	2.31	LGG2Z332MELC50

200V (2D)				
Cap. (μF)	Size φD x L(mm)	Rated ripple (mArms)	Leakage Current (mA)	Code
470	22 x 25	1200	0.91	LGG2D471MELZ25
560	22 x 30	1480	1.00	LGG2D561MELZ30
	25 x 25	1480	1.00	LGG2D561MELA25
680	22 x 35	1600	1.10	LGG2D681MELZ35
	25 x 30	1600	1.10	LGG2D681MELA30
820	22 x 40	1750	1.21	LGG2D821MELZ40
	25 x 35	1750	1.21	LGG2D821MELA35
1000	30 x 25	1750	1.21	LGG2D821MELB25
	22 x 45	2040	1.34	LGG2D102MELZ45
	25 x 40	2040	1.34	LGG2D102MELA40
1200	30 x 30	2040	1.34	LGG2D102MELB30
	25 x 45	2300	1.46	LGG2D122MELA45
	30 x 35	2300	1.46	LGG2D122MELB35
1500	35 x 25	2300	1.46	LGG2D122MELC25
	25 x 50	2570	1.64	LGG2D152MELA50
	30 x 40	2570	1.64	LGG2D152MELB40
1800	35 x 30	2570	1.64	LGG2D152MELC30
	30 x 45	2680	1.80	LGG2D182MELB45
2200	35 x 35	2680	1.80	LGG2D182MELC35
	30 x 50	2920	1.98	LGG2D222MELB50
2700	35 x 40	2920	1.98	LGG2D222MELC40
	35 x 45	3270	2.20	LGG2D272MELC45

220V (2P)				
Cap. (μF)	Size φD x L(mm)	Rated ripple (mArms)	Leakage Current (mA)	Code
330	22 x 25	1260	0.80	LGG2P331MELZ25
390	22 x 30	1340	0.87	LGG2P391MELZ30
470	22 x 35	1480	0.96	LGG2P471MELZ35
	25 x 25	1400	0.96	LGG2P471MELA25
560	22 x 35	1450	1.05	LGG2P561MELZ35
	25 x 30	1450	1.05	LGG2P561MELA30
680	22 x 40	1650	1.16	LGG2P681MELZ40
	25 x 35	1780	1.16	LGG2P681MELA35
	30 x 25	1650	1.16	LGG2P681MELB25
820	22 x 50	1930	1.27	LGG2P821MELZ50
	25 x 40	1930	1.27	LGG2P821MELA40
	30 x 30	1850	1.27	LGG2P821MELB30
1000	35 x 25	1930	1.27	LGG2P821MELC25
	25 x 45	2150	1.40	LGG2P102MELA45
	30 x 35	2330	1.40	LGG2P102MELB35
1200	35 x 30	2330	1.40	LGG2P102MELC30
	30 x 40	2500	1.54	LGG2P122MELB40
1500	35 x 30	2350	1.54	LGG2P122MELC30
	30 x 45	2550	1.72	LGG2P152MELB45
1800	35 x 35	2500	1.72	LGG2P152MELC35
	35 x 40	2700	1.88	LGG2P182MELC40
2200	35 x 50	2950	2.08	LGG2P222MELC50

Rated ripple current (mArms) at 105°C 120Hz

## LGG

### ■ Dimensions

250V (2E)				
Cap. (μF)	Size ϕD x L(mm)	Rated ripple (mAmps)	Leakage Current (mA)	Code
390	22 x 30	1200	0.93	LGG2E391MELZ30
	25 x 25	1200	0.93	LGG2E391MELA25
470	22 x 35	1300	1.02	LGG2E471MELZ35
	25 x 30	1300	1.02	LGG2E471MELA30
560	22 x 40	1400	1.12	LGG2E561MELZ40
	25 x 35	1500	1.12	LGG2E561MELA35
680	30 x 25	1400	1.12	LGG2E561MELB25
	22 x 45	1500	1.23	LGG2E681MELZ45
820	25 x 40	1700	1.23	LGG2E681MELA40
	30 x 30	1700	1.23	LGG2E681MELB30
820	25 x 45	2000	1.35	LGG2E821MELA45
	30 x 35	2000	1.35	LGG2E821MELB35
	35 x 30	2000	1.35	LGG2E821MELC30
1000	25 x 50	2200	1.50	LGG2E102MELA50
	30 x 40	2200	1.50	LGG2E102MELB40
	35 x 30	2000	1.50	LGG2E102MELC30
1200	30 x 45	2300	1.64	LGG2E122MELB45
	35 x 35	2200	1.64	LGG2E122MELC35
1500	30 x 50	2300	1.83	LGG2E152MELB50
	35 x 40	2300	1.83	LGG2E152MELC40
1800	35 x 45	2500	2.01	LGG2E182MELC45

400V (2G)				
Cap. (μF)	Size ϕD x L(mm)	Rated ripple (mAmps)	Leakage Current (mA)	Code
120	22 x 25	680	0.65	LGG2G121MELZ25
180	22 x 30	730	0.80	LGG2G181MELZ30
	25 x 25	730	0.80	LGG2G181MELA25
220	22 x 35	850	0.88	LGG2G221MELZ35
	25 x 30	850	0.88	LGG2G221MELA30
270	22 x 40	1000	0.98	LGG2G271MELZ40
	25 x 35	1000	0.98	LGG2G271MELA35
	30 x 25	1000	0.98	LGG2G271MELB25
330	22 x 50	1150	1.08	LGG2G331MELZ50
	25 x 40	1150	1.08	LGG2G331MELA40
	30 x 30	1150	1.08	LGG2G331MELB30
	35 x 25	1150	1.08	LGG2G331MELC25
390	25 x 45	1400	1.18	LGG2G391MELA45
	30 x 35	1400	1.18	LGG2G391MELB35
	35 x 30	1550	1.18	LGG2G391MELC30
470	25 x 50	1550	1.30	LGG2G471MELA50
	30 x 40	1550	1.30	LGG2G471MELB40
	35 x 30	1550	1.30	LGG2G471MELC30
560	30 x 45	1630	1.41	LGG2G561MELB45
	35 x 35	1630	1.41	LGG2G561MELC35
680	30 x 50	1800	1.56	LGG2G681MELB50
	35 x 40	1800	1.56	LGG2G681MELC40
820	35 x 45	2000	1.71	LGG2G821MELC45
1000	35 x 50	2140	1.89	LGG2G102MELC50

420V (W6)				
Cap. (μF)	Size ϕD x L(mm)	Rated ripple (mAmps)	Leakage Current (mA)	Code
120	22 x 30	810	0.67	LGGW6121MELZ30
150	22 x 35	840	0.75	LGGW6151MELZ35
	25 x 25	820	0.75	LGGW6151MELA25
180	22 x 35	850	0.82	LGGW6181MELZ35
	25 x 30	910	0.82	LGGW6181MELA30
220	22 x 40	950	0.91	LGGW6221MELZ40
	25 x 35	1050	0.91	LGGW6221MELA35
	30 x 25	950	0.91	LGGW6221MELB25
270	22 x 50	1150	1.01	LGGW6271MELZ50
	25 x 40	1250	1.01	LGGW6271MELA40
	30 x 30	1250	1.01	LGGW6271MELB30
330	25 x 45	1350	1.11	LGGW6331MELA45
	30 x 35	1420	1.11	LGGW6331MELB35
	35 x 30	1420	1.11	LGGW6331MELC30
390	25 x 50	1450	1.21	LGGW6391MELA50
	30 x 40	1610	1.21	LGGW6391MELB40
	35 x 30	1450	1.21	LGGW6391MELC30
470	30 x 45	1860	1.33	LGGW6471MELB45
	35 x 35	1700	1.33	LGGW6471MELC35
560	35 x 40	1900	1.45	LGGW6561MELC40
680	35 x 45	2050	1.60	LGGW6681MELC45

450V (2W)				
Cap. (μF)	Size ϕD x L(mm)	Rated ripple (mAmps)	Leakage Current (mA)	Code
100	22 x 25	640	0.63	LGG2W101MELZ25
120	22 x 30	690	0.69	LGG2W121MELZ30
	25 x 25	690	0.69	LGG2W121MELA25
150	22 x 35	720	0.77	LGG2W151MELZ35
	25 x 30	790	0.77	LGG2W151MELA30
180	22 x 40	790	0.85	LGG2W181MELZ40
	25 x 30	790	0.85	LGG2W181MELA30
220	22 x 45	870	0.94	LGG2W221MELZ45
	25 x 35	870	0.94	LGG2W221MELA35
	30 x 30	790	0.94	LGG2W221MELB30
270	22 x 50	1050	1.04	LGG2W271MELZ50
	25 x 40	1050	1.04	LGG2W271MELA40
	30 x 30	1050	1.04	LGG2W271MELB30
	35 x 25	1050	1.04	LGG2W271MELC25
330	25 x 50	1200	1.15	LGG2W331MELA50
	30 x 35	1200	1.15	LGG2W331MELB35
	35 x 30	1200	1.15	LGG2W331MELC30
390	30 x 40	1380	1.25	LGG2W391MELB40
	35 x 35	1380	1.25	LGG2W391MELC35
	30 x 45	1550	1.37	LGG2W471MELB45
470	35 x 40	1550	1.37	LGG2W471MELC40
	35 x 45	1700	1.50	LGG2W561MELC45
680	35 x 50	1910	1.65	LGG2W681MELC50

### ● Frequency coefficient of rated ripple current

Coeff.	Frequency (Hz)	50	60	120	300	1k	10k	50k or more
	160 to 250V	0.81	0.85	1.00	1.17	1.32	1.45	1.50
400 to 450V	0.77	0.82	1.00	1.16	1.30	1.41	1.43	

Rated ripple current (mAmps) at 105°C 120Hz

# ALUMINUM ELECTROLYTIC CAPACITORS

# LGL

Snap-in Terminal Type, 105°C Ultra-Smaller-Sized



Smaller

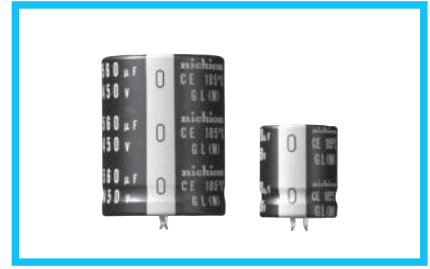

- One rank smaller case sized than LGG.
- Suited for equipment down sizing.
- Compliant to the RoHS directive (2011/65/EU,(EU)2015/863).

## Specifications

Item	Performance Characteristics				
Category Temperature Range	- 25 to +105°C				
Rated Voltage Range	400 · 450V				
Rated Capacitance Range	120 to 1000µF				
Capacitance Tolerance	±20% at 120Hz, 20°C				
Leakage Current	$I \leq 3\sqrt{CV}$ (µA) (After 5 minutes' application of rated voltage) [C : Rated Capacitance (µF) V : Voltage (V)]				
Tangent of loss angle (tan δ)	Rated voltage (V)	400      450	Measurement frequency : 120Hz at 20°C		
	tan δ (MAX.)	0.15      0.20			
Stability at Low Temperature	Rated voltage (V)	400 · 450		Measurement frequency : 120Hz	
	Impedance ratio ZT/Z20 (MAX.)	Z - 25°C/Z+20°C			
Endurance	The specifications listed at right shall be met when the capacitors are restored to 20°C after D.C. bias plus rated ripple current is applied for 2000 hours at 105°C, the peak voltage shall not exceed the rated voltage.			Capacitance change	Within ±20% of the initial capacitance value
				tan δ	200% or less than the initial specified value
				Leakage current	Less than or equal to the initial specified value
Shelf Life	After storing the capacitors under no load at 105°C for 1000 hours and then performing voltage treatment based on JIS C 5101-4 clause 4.1 at 20°C, they shall meet the characteristic requirements listed at right.			Capacitance change	Within ±20% of the initial capacitance value
				tan δ	200% or less than the initial specified value
				Leakage current	Less than or equal to the initial specified value
Marking	Printed with white color letter on black sleeve.				

## Drawing

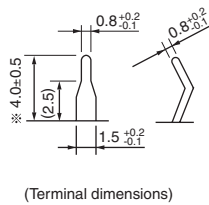
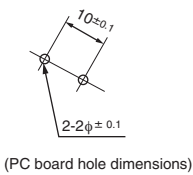
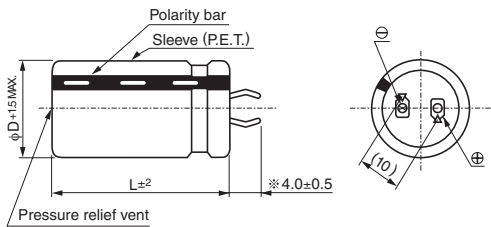

\* Other terminations available upon request.  
Please refer to the Guidelines for Aluminum Electrolytic Capacitors.

## Type numbering system (Example : 400V 150µF)

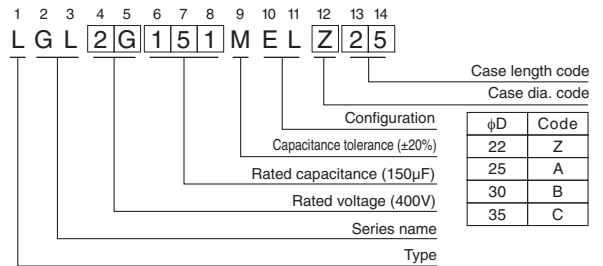

## Frequency coefficient of rated ripple current

Frequency (Hz)	50	60	120	300	1 k	10k	50k or more
Coeff.	400 - 450V	0.77	0.82	1.00	1.16	1.30	1.41

Minimum order quantity : 50pcs.

● Dimension table in next page.

LGL

## ■ Dimensions

400V (2G)				
Cap. (μF)	Size φD × L(mm)	Rated ripple (mArms)	Leakage Current (mA)	Code
150	22 × 25	730	0.73	LGL2G151MELZ25
220	22 × 30	780	0.88	LGL2G221MELZ30
	25 × 25	780	0.88	LGL2G221MELA25
270	22 × 35	910	0.98	LGL2G271MELZ35
	25 × 30	910	0.98	LGL2G271MELA30
330	22 × 45	1070	1.08	LGL2G331MELZ45
	25 × 35	1070	1.08	LGL2G331MELA35
	30 × 25	1040	1.08	LGL2G331MELB25
390	22 × 50	1230	1.18	LGL2G391MELZ50
	25 × 40	1230	1.18	LGL2G391MELA40
	30 × 30	1230	1.18	LGL2G391MELB30
	35 × 25	1180	1.18	LGL2G391MELC25
470	25 × 45	1500	1.30	LGL2G471MELA45
	30 × 35	1500	1.30	LGL2G471MELB35
560	30 × 40	1660	1.41	LGL2G561MELB40
	35 × 30	1660	1.41	LGL2G561MELC30
680	30 × 45	1740	1.56	LGL2G681MELB45
	35 × 35	1740	1.56	LGL2G681MELC35
820	30 × 50	1920	1.71	LGL2G821MELB50
	35 × 40	1920	1.71	LGL2G821MELC40
1000	35 × 50	2200	1.89	LGL2G102MELC50

450V (2W)				
Cap. (μF)	Size φD × L(mm)	Rated ripple (mArms)	Leakage Current (mA)	Code
120	22 × 25	690	0.69	LGL2W121MELZ25
150	22 × 30	740	0.77	LGL2W151MELZ30
	25 × 25	740	0.77	LGL2W151MELA25
180	22 × 35	770	0.85	LGL2W181MELZ35
	25 × 30	770	0.85	LGL2W181MELA30
220	22 × 40	850	0.94	LGL2W221MELZ40
	25 × 35	850	0.94	LGL2W221MELA35
	30 × 25	820	0.94	LGL2W221MELB25
270	22 × 45	930	1.04	LGL2W271MELZ45
	25 × 40	930	1.04	LGL2W271MELA40
	30 × 30	930	1.04	LGL2W271MELB30
330	25 × 45	1120	1.15	LGL2W331MELA45
	30 × 35	1120	1.15	LGL2W331MELB35
	35 × 25	1070	1.15	LGL2W331MELC25
390	25 × 50	1280	1.25	LGL2W391MELA50
	30 × 40	1280	1.25	LGL2W391MELB40
	35 × 30	1280	1.25	LGL2W391MELC30
470	30 × 45	1480	1.37	LGL2W471MELB45
	35 × 35	1480	1.37	LGL2W471MELC35
560	30 × 50	1660	1.50	LGL2W561MELB50
	35 × 40	1660	1.50	LGL2W561MELC40
680	35 × 45	1770	1.65	LGL2W681MELC45
820	35 × 50	1930	1.82	LGL2W821MELC50

Rated ripple current (mArms) at 105°C 120Hz

# ALUMINUM ELECTROLYTIC CAPACITORS



# LGM

Snap-in Terminal Type, 105°C Ultra-Smaller-Sized



- One rank smaller case sized than LGL.
- Suited for equipment down sizing.
- Compliant to the RoHS directive (2011/65/EU, (EU)2015/863).

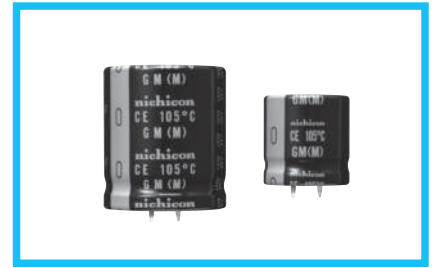
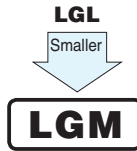

## Specifications

Item	Performance Characteristics	
Category Temperature Range	- 25 to +105°C	
Rated Voltage Range	450V	
Rated Capacitance Range	180 to 820μF	
Capacitance Tolerance	±20% at 120Hz, 20°C	
Leakage Current	After 5 minutes' application of rated voltage at 20°C, leakage current is not more than $3\sqrt{CV}$ (μA) or 5 mA, whichever is smaller (at 20°C).	
Tangent of loss angle (tan δ)	0.20MAX. 120Hz at 20°C	
Stability at Low Temperature	Rated voltage (V)	450
	Impedance ratio ZT/Z20(MAX.)	Z - 25°C / Z+20°C 8
Endurance	The specifications listed at right shall be met when the capacitors are restored to 20°C after D.C. bias plus rated ripple current is applied for 2000 hours at 105°C, the peak voltage shall not exceed the rated voltage.	
	Capacitance change	Within ±20% of the initial capacitance value
	tan δ	200% or less than the initial specified value
Shelf Life	After storing the capacitors under no load at 105°C for 1000 hours and then performing voltage treatment based on JIS C 5101-4 clause 4.1 at 20°C, they shall meet the characteristic requirements listed at right.	
	Capacitance change	Within ±20% of the initial capacitance value
	Leakage current	Less than or equal to the initial specified value
Marking	Printed with white color letter on black sleeve.	

## Drawing

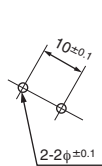
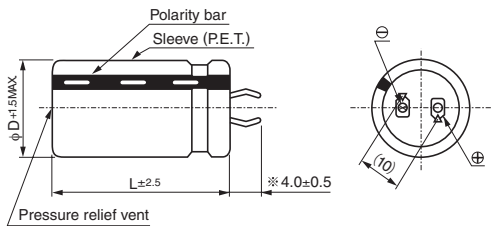

(PC board hole dimensions)

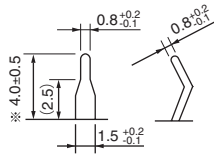

(Terminal dimensions)

\* Other terminations available upon request. Please refer to the Guidelines for Aluminum Electrolytic Capacitors.

## Type numbering system (Example : 450V 180μF)

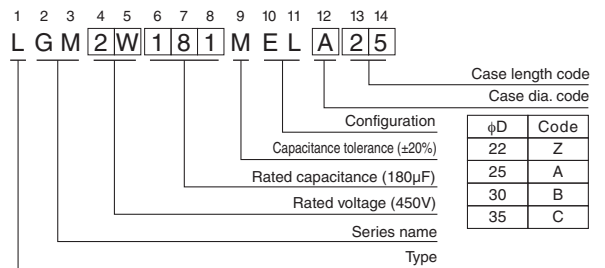

## Dimensions

450V (2W)				
Cap. (μF)	Size φD × L(mm)	Rated ripple (mArms)	Leakage Current (mA)	Code
180	22 × 30	470	0.85	LGM2W181MELZ30
	25 × 25	470	0.85	LGM2W181MELA25
220	22 × 35	550	0.94	LGM2W221MELZ35
	25 × 30	550	0.94	LGM2W221MELA30
270	25 × 35	650	1.04	LGM2W271MELA35
	30 × 25	650	1.04	LGM2W271MELB25
330	25 × 40	750	1.15	LGM2W331MELA40
	30 × 30	730	1.15	LGM2W331MELB30
390	25 × 45	900	1.25	LGM2W391MELA45
	30 × 35	900	1.25	LGM2W391MELB35
470	30 × 40	1000	1.37	LGM2W471MELB40
	35 × 30	1000	1.37	LGM2W471MELC30
560	30 × 45	1200	1.50	LGM2W561MELB45
	35 × 35	1200	1.50	LGM2W561MELC35
680	35 × 40	1400	1.65	LGM2W681MELC40
820	35 × 45	1600	1.82	LGM2W821MELC45

Rated ripple current (mArms) at 105°C 120Hz

## Frequency coefficient of rated ripple current

Frequency (Hz)	50	60	120	300	1 k	10k	50k or more
Coefficient	0.77	0.82	1.00	1.16	1.30	1.41	1.43

Minimum order quantity : 50pcs.

CAT.8100K

# ALUMINUM ELECTROLYTIC CAPACITORS

# LGJ

Snap-in Terminal Type, 105°C Low-Profile Sized



LGU



Low Profile  
**LGJ**



Low Profile  
**LGJ(15)**

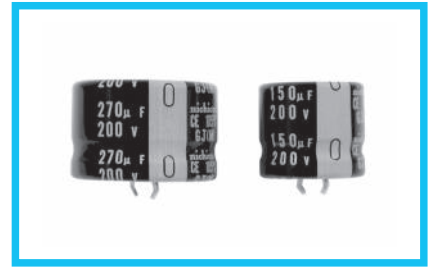

- Withstanding 3000 hours application of rated ripple current at 105°C.
- Ideally suited for flat design fo switching power supply.
- Addition of 450V rated voltage.
- Compliant to the RoHS directive (2011/65/EU,(EU)2015/863).

## Specifications

Item	Performance Characteristics	
Category Temperature Range	- 40 to +105°C (200 · 250V) , - 25 to +105°C (400 · 450V)	
Rated Voltage Range	200 to 450V	
Rated Capacitance Range	47 to 680µF	
Capacitance Tolerance	±20% at 120Hz, 20°C	
Leakage Current	3√CV (µA) (After 5 minutes' application of rated voltage) [C : Rated Capacitance (µF) V : Voltage (V)]	
Tangent of loss angle (tan δ)	Rated voltage(V)	200 to 400      450
	tan δ (MAX.)	0.15      0.20
Stability at Low Temperature	Measurement frequency : 120Hz	
	Rated voltage(V)	200 · 250      400 · 450
	Impedance ratio ZT/Z20(MAX.)	Z - 25°C/Z+20°C      3      8 Z - 40°C/Z+20°C      12      —
Endurance	The specifications listed at right shall be met when the capacitors are restored to 20°C after D.C. bias plus rated ripple current is applied for 3000 hours at 105°C, the peak voltage shall not exceed the rated voltage.	
	Capacitance change	Within ±20% of the initial capacitance value
	tan δ	200% or less than the initial specified value
Shelf Life	After storing the capacitors under no load at 105°C for 1000 hours and then performing voltage treatment based on JIS C 5101-4 clause 4.1 at 20°C, they shall meet the requirements listed at right.	
	Capacitance change	Within ±15% of the initial capacitance value
	tan δ	150% or less than the initial specified value
Marking	Printed with white color letter on black sleeve.	

Since rating other than the above can be manufactured a please ask for detail.

## Drawing

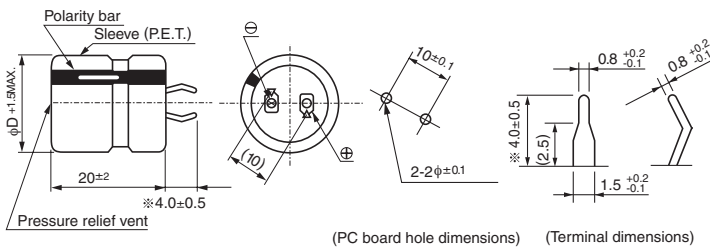

## Type numbering system (Example : 400V 120µF)

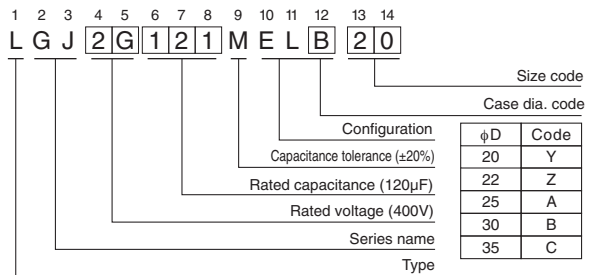

\* Other terminations available upon request.  
Please refer to the Guidelines for Aluminum Electrolytic Capacitors.

## Frequency coefficient of rated ripple current

Frequency (Hz)	50	60	120	300	1 k	10k	50k or more
Coef. 200 to 250V	0.81	0.85	1.00	1.17	1.32	1.45	1.50
400 to 450V	0.77	0.82	1.00	1.16	1.30	1.41	1.43

Minimum order quantity : 50pcs.

● Dimension table in next page.





## ■ Dimensions

200V(2D)				
Cap. (μF)	Size φD × L(mm)	Rated ripple (mArms)	Leakage Current (mA)	Code
180	20 × 20	680	0.56	LGJ2D181MELY20
220	22 × 20	760	0.62	LGJ2D221MELZ20
270	22 × 20	780	0.69	LGJ2D271MELZ20
330	25 × 20	960	0.77	LGJ2D331MELA20
390	30 × 20	1080	0.83	LGJ2D391MELB20
470	30 × 20	1120	0.91	LGJ2D471MELB20
560	35 × 20	1440	1.00	LGJ2D561MELC20
680	35 × 20	1520	1.10	LGJ2D681MELC20

250V(2E)				
Cap. (μF)	Size φD × L(mm)	Rated ripple (mArms)	Leakage Current (mA)	Code
150	20 × 20	660	0.58	LGJ2E151MELY20
180	22 × 20	750	0.63	LGJ2E181MELZ20
220	25 × 20	920	0.70	LGJ2E221MELA20
270	30 × 20	1040	0.77	LGJ2E271MELB20
330	30 × 20	1080	0.86	LGJ2E331MELB20
390	35 × 20	1410	0.93	LGJ2E391MELC20
470	35 × 20	1470	1.02	LGJ2E471MELC20

400V(2G)				
Cap. (μF)	Size φD × L(mm)	Rated ripple (mArms)	Leakage Current (mA)	Code
56	20 × 20	550	0.44	LGJ2G560MELY20
68	22 × 20	620	0.49	LGJ2G680MELZ20
82	25 × 20	700	0.54	LGJ2G820MELA20
100	25 × 20	760	0.60	LGJ2G101MELA20
120	30 × 20	860	0.65	LGJ2G121MELB20
150	30 × 20	900	0.73	LGJ2G151MELB20
180	35 × 20	1160	0.80	LGJ2G181MELC20
220	35 × 20	1210	0.88	LGJ2G221MELC20

450V(2W)				
Cap. (μF)	Size φD × L(mm)	Rated ripple (mArms)	Leakage Current (mA)	Code
47	20 × 20	520	0.43	LGJ2W470MELY20
56	22 × 20	600	0.47	LGJ2W560MELZ20
68	25 × 20	670	0.52	LGJ2W680MELA20
82	25 × 20	740	0.57	LGJ2W820MELA20
100	30 × 20	830	0.63	LGJ2W101MELB20
120	30 × 20	870	0.69	LGJ2W121MELB20
150	35 × 20	1170	0.77	LGJ2W151MELC20

Rated ripple current (mArms) at 105°C 120Hz

# ALUMINUM ELECTROLYTIC CAPACITORS

## LGJ<sub>(15)</sub>

Snap-in Terminal Type, 105°C Low-Profile Sized (15mmL)



- Withstanding 2000 hours application of rated ripple current at 105°C.
- Smaller than low-profile LGJ.
- Ideally suited for flat design of switching power supply.
- Compliant to the RoHS directive (2011/65/EU, (EU)2015/863).

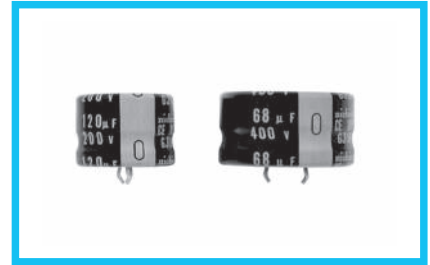
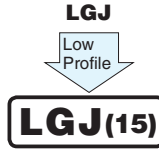

### Specifications

Item	Performance Characteristics						
Category Temperature Range	- 40 to +105°C (160 to 250V) , - 25 to +105°C (315 • 400V)						
Rated Voltage Range	160 to 400V						
Rated Capacitance Range	39 to 390µF						
Capacitance Tolerance	±20% at 120Hz, 20°C						
Leakage Current	$I \leq 3\sqrt{CV}$ (µA) (After 5 minutes' application of rated voltage) [C : Rated Capacitance (µF) V : Voltage (V)]						
Tangent of loss angle (tan δ)	0.20 MAX. 120Hz at 20°C						
Stability at Low Temperature	Measurement frequency : 120Hz						
	Rated voltage(V)	160 to 250      315 • 400					
	Impedance ratio ZT/Z20(MAX.)	<table border="1"> <tr> <td>Z - 25°C/Z+20°C</td> <td>3</td> <td>8</td> </tr> <tr> <td>Z - 40°C/Z+20°C</td> <td>12</td> <td>—</td> </tr> </table>	Z - 25°C/Z+20°C	3	8	Z - 40°C/Z+20°C	12
Z - 25°C/Z+20°C	3	8					
Z - 40°C/Z+20°C	12	—					
Endurance	The specifications listed at right shall be met when the capacitors are restored to 20°C after D.C. bias plus rated ripple current is applied for 2000 hours at 105°C, the peak voltage shall not exceed the rated voltage.						
	Capacitance change	Within ±20% of the initial capacitance value					
	tan δ	200% or less than the initial specified value					
Shelf Life	After storing the capacitors under no load at 105°C for 1000 hours and then performing voltage treatment based on JIS C 5101-4 clause 4.1 at 20°C, they shall meet the requirements listed at right.						
	Capacitance change	Within ±15% of the initial capacitance value					
	tan δ	150% or less than the initial specified value					
Leakage current	Less than or equal to the initial specified value						
Marking	Printed with white color letter on black sleeve.						

### Drawing

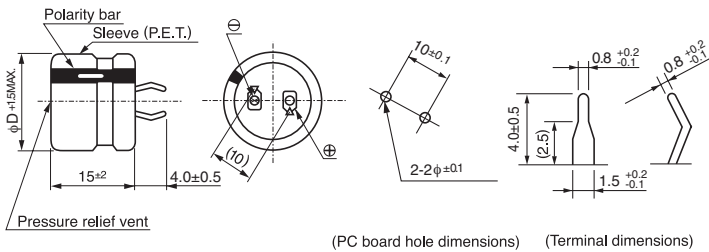

### Type numbering system (Example : 200V 330µF)

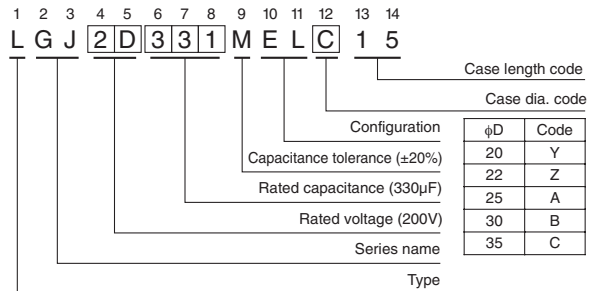

### Frequency coefficient of rated ripple current

Frequency (Hz)	50	60	120	300	1 k	10k	50k or more
Coeff. 160 to 250V	0.81	0.85	1.00	1.17	1.32	1.45	1.50
315 • 400V	0.77	0.82	1.00	1.16	1.30	1.41	1.43

Minimum order quantity : 50pcs.

● Dimension table in next page.



## ■ Dimensions

160V(2C)				
Cap. (μF)	Size φD × L(mm)	Rated ripple (mArms)	Leakage Current (mA)	Code
150	20 × 15	550	0.46	LGJ2C151MELY15
180	22 × 15	650	0.50	LGJ2C181MELZ15
220	25 × 15	800	0.56	LGJ2C221MELA15
270	30 × 15	950	0.62	LGJ2C271MELB15
330	30 × 15	1000	0.68	LGJ2C331MELB15
390	35 × 15	1200	0.74	LGJ2C391MELC15

180V(2Z)				
Cap. (μF)	Size φD × L(mm)	Rated ripple (mArms)	Leakage Current (mA)	Code
120	20 × 15	500	0.44	LGJ2Z121MELY15
150	22 × 15	600	0.49	LGJ2Z151MELZ15
180	25 × 15	750	0.54	LGJ2Z181MELA15
220	30 × 15	850	0.59	LGJ2Z221MELB15
270	30 × 15	1000	0.66	LGJ2Z271MELB15
330	35 × 15	1100	0.73	LGJ2Z331MELC15
390	35 × 15	1200	0.79	LGJ2Z391MELC15

200V(2D)				
Cap. (μF)	Size φD × L(mm)	Rated ripple (mArms)	Leakage Current (mA)	Code
100	20 × 15	450	0.42	LGJ2D101MELY15
120	22 × 15	550	0.46	LGJ2D121MELZ15
150	25 × 15	650	0.51	LGJ2D151MELA15
180	25 × 15	750	0.56	LGJ2D181MELA15
220	30 × 15	900	0.62	LGJ2D221MELB15
270	30 × 15	1000	0.69	LGJ2D271MELB15
330	35 × 15	1100	0.77	LGJ2D331MELC15

250V(2E)				
Cap. (μF)	Size φD × L(mm)	Rated ripple (mArms)	Leakage Current (mA)	Code
100	22 × 15	500	0.47	LGJ2E101MELZ15
120	25 × 15	600	0.51	LGJ2E121MELA15
150	30 × 15	700	0.58	LGJ2E151MELB15
180	30 × 15	750	0.63	LGJ2E181MELB15
220	35 × 15	900	0.70	LGJ2E221MELC15
270	35 × 15	1000	0.77	LGJ2E271MELC15

315V(2F)				
Cap. (μF)	Size φD × L(mm)	Rated ripple (mArms)	Leakage Current (mA)	Code
56	22 × 15	350	0.39	LGJ2F560MELZ15
68	25 × 15	400	0.43	LGJ2F680MELA15
82	30 × 15	450	0.48	LGJ2F820MELB15
100	30 × 15	500	0.53	LGJ2F101MELB15
120	35 × 15	550	0.58	LGJ2F121MELC15
150	35 × 15	600	0.65	LGJ2F151MELC15

400V(2G)				
Cap. (μF)	Size φD × L(mm)	Rated ripple (mArms)	Leakage Current (mA)	Code
39	22 × 15	300	0.37	LGJ2G390MELZ15
47	25 × 15	350	0.41	LGJ2G470MELA15
56	30 × 15	400	0.44	LGJ2G560MELB15
68	30 × 15	450	0.49	LGJ2G680MELB15
82	35 × 15	500	0.54	LGJ2G820MELC15
100	35 × 15	550	0.60	LGJ2G101MELC15

Rated ripple current (mArms) at 105°C 120Hz

# LGY

Snap-in Terminal Type, 105°C Long Life Assurance



- Long life assurance series withstanding 5000 hours application of ripple current at 105°C.
- Suited for use in industrial power supplies applications where high reliability and dependable performance are the most important.
- Suited for ballast application.
- Compliant to the RoHS directive (2011/65/EU,(EU)2015/863).

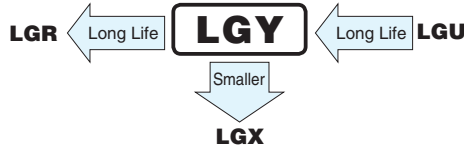
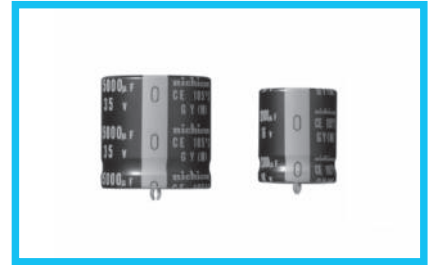

## Specifications

Item	Performance Characteristics						
Category Temperature Range	-40 to +105°C						
Rated Voltage Range	16 to 100V						
Rated Capacitance Range	560 to 47000μF						
Capacitance Tolerance	±20% at 120Hz, 20°C						
Leakage Current	$I \leq 3\sqrt{CV}$ (μA) (After 5 minutes' application of rated voltage) [C : Rated Capacitance (μF) V : Voltage (V)]						
Tangent of loss angle (tan δ)	Measurement frequency : 120Hz at 20°C						
	Rated voltage(V)	16	25	35	50	63	80 · 100
	tan δ (MAX.)	0.50	0.40	0.35	0.30	0.25	0.20
Stability at Low Temperature	Measurement frequency : 120Hz						
	Rated voltage(V)			16 to 100			
	Impedance ratio	Z-25°C/Z+20°C		4			
	ZT/Z20 (MAX.)	Z-40°C/Z+20°C		20			
Endurance	The specifications listed at right shall be met when the capacitors are restored to 20°C after D.C. bias plus rated ripple current is applied for 5000 hours at 105°C, the peak voltage shall not exceed the rated voltage.						
	Capacitance change	Within ±25% of the initial capacitance value					
	tan δ	250% or less than the initial specified value					
Shelf Life	After storing the capacitors under no load at 105°C for 1000 hours and then performing voltage treatment based on JIS C 5101-4 clause 4.1 at 20°C, they shall meet the requirements listed at right.						
	Capacitance change	Within ±15% of the initial capacitance value					
	tan δ	150% or less than the initial specified value					
Marking	Printed with white color letter on black sleeve.						
	Leakage current	Less than or equal to the initial specified value					

## Drawing

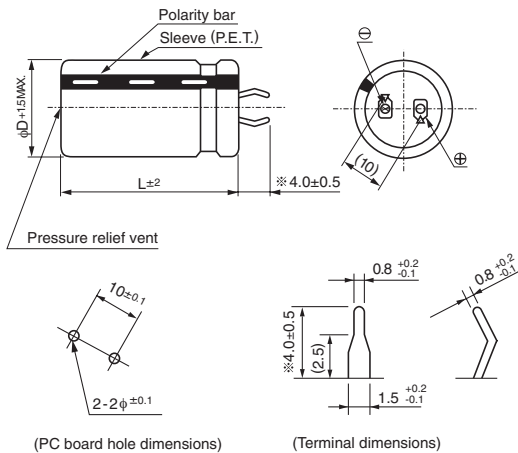

## Type numbering system (Example : 100V 680μF)

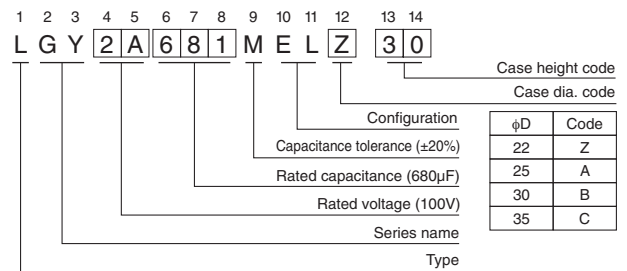

\* Other terminations available upon request.  
Please refer to the Guidelines for Aluminum Electrolytic Capacitors.

## Frequency coefficient of rated ripple current

Frequency (Hz)	50	60	120	300	1k	10k	50k or more
16 to 100V	0.88	0.90	1.00	1.07	1.15	1.15	1.15

Minimum order quantity : 50pcs.

● Dimension table in next page.

## LGY

### ■ Dimensions

16V (1C)				
Cap. (μF)	Size φD × L (mm)	Rated ripple (mArms)	Leakage Current (mA)	Code
6800	22 × 25	1800	0.98	LGY1C682MELZ25
8200	22 × 30	2000	1.08	LGY1C822MELZ30
10000	22 × 30	2200	1.20	LGY1C103MELZ30
	25 × 25	2200	1.20	LGY1C103MELA25
12000	22 × 35	2400	1.31	LGY1C123MELZ35
	25 × 30	2400	1.31	LGY1C123MELA30
	30 × 25	2400	1.31	LGY1C123MELB25
15000	22 × 40	2700	1.46	LGY1C153MELZ40
	25 × 35	2700	1.46	LGY1C153MELA35
	30 × 30	2700	1.46	LGY1C153MELB30
18000	22 × 50	3000	1.60	LGY1C183MELZ50
	25 × 40	3000	1.60	LGY1C183MELA40
	30 × 30	3000	1.60	LGY1C183MELB30
22000	25 × 45	3300	1.77	LGY1C223MELA45
	30 × 35	3300	1.77	LGY1C223MELB35
	35 × 30	3300	1.77	LGY1C223MELC30
27000	25 × 50	3600	1.97	LGY1C273MELA50
	30 × 40	3600	1.97	LGY1C273MELB40
	35 × 30	3600	1.97	LGY1C273MELC30
33000	30 × 45	4000	2.17	LGY1C333MELB45
	35 × 35	4000	2.17	LGY1C333MELC35
39000	30 × 50	4300	2.36	LGY1C393MELB50
	35 × 40	4300	2.36	LGY1C393MELC40
47000	35 × 45	4700	2.60	LGY1C473MELC45

25V (1E)				
Cap. (μF)	Size φD × L (mm)	Rated ripple (mArms)	Leakage Current (mA)	Code
4700	22 × 25	1600	1.02	LGY1E472MELZ25
5600	22 × 30	1800	1.12	LGY1E562MELZ30
6800	22 × 30	1900	1.23	LGY1E682MELZ30
	25 × 25	1900	1.23	LGY1E682MELA25
8200	22 × 35	2100	1.35	LGY1E822MELZ35
	25 × 30	2100	1.35	LGY1E822MELA30
	30 × 25	2100	1.35	LGY1E822MELB25
10000	22 × 40	2300	1.50	LGY1E103MELZ40
	25 × 35	2300	1.50	LGY1E103MELA35
	30 × 30	2300	1.50	LGY1E103MELB30
12000	22 × 45	2600	1.64	LGY1E123MELZ45
	25 × 40	2600	1.64	LGY1E123MELA40
	30 × 30	2600	1.64	LGY1E123MELB30
15000	25 × 45	2900	1.83	LGY1E153MELA45
	30 × 35	2900	1.83	LGY1E153MELB35
	35 × 30	2900	1.83	LGY1E153MELC30
18000	25 × 50	3100	2.01	LGY1E183MELA50
	30 × 40	3100	2.01	LGY1E183MELB40
	35 × 35	3100	2.01	LGY1E183MELC35
	30 × 45	3500	2.22	LGY1E223MELB45
22000	35 × 35	3500	2.22	LGY1E223MELC35
	35 × 45	3800	2.46	LGY1E273MELC45
33000	35 × 50	4200	2.72	LGY1E333MELC50

35V (1V)				
Cap. (μF)	Size φD × L (mm)	Rated ripple (mArms)	Leakage Current (mA)	Code
3300	22 × 25	1500	1.01	LGY1V332MELZ25
3900	22 × 30	1600	1.10	LGY1V392MELZ30
4700	22 × 35	1800	1.21	LGY1V472MELZ35
	25 × 25	1800	1.21	LGY1V472MELA25
5600	22 × 35	2000	1.32	LGY1V562MELZ35
	25 × 30	2000	1.32	LGY1V562MELA30
	30 × 25	2000	1.32	LGY1V562MELB25
6800	22 × 40	2200	1.46	LGY1V682MELZ40
	25 × 35	2200	1.46	LGY1V682MELA35
	30 × 25	2200	1.46	LGY1V682MELB25
8200	22 × 50	2400	1.60	LGY1V822MELZ50
	25 × 40	2400	1.60	LGY1V822MELA40
	30 × 30	2400	1.60	LGY1V822MELB30
10000	25 × 45	2600	1.77	LGY1V103MELA45
	30 × 35	2600	1.77	LGY1V103MELB35
12000	25 × 50	2900	1.94	LGY1V123MELA50
	30 × 40	2900	1.94	LGY1V123MELB40
	35 × 30	2900	1.94	LGY1V123MELC30
15000	30 × 45	3200	2.17	LGY1V153MELB45
	35 × 35	3200	2.17	LGY1V153MELC35
18000	35 × 40	3500	2.38	LGY1V183MELC40
22000	35 × 50	3900	2.63	LGY1V223MELC50

50V (1H)				
Cap. (μF)	Size φD × L (mm)	Rated ripple (mArms)	Leakage Current (mA)	Code
1800	22 × 25	1300	0.90	LGY1H182MELZ25
2200	22 × 25	1400	0.99	LGY1H222MELZ25
2700	22 × 30	1600	1.10	LGY1H272MELZ30
	25 × 25	1600	1.10	LGY1H272MELA25
3300	22 × 35	1800	1.21	LGY1H332MELZ35
	25 × 30	1800	1.21	LGY1H332MELA30
3900	22 × 40	1900	1.32	LGY1H392MELZ40
	25 × 30	1900	1.32	LGY1H392MELA30
	30 × 25	1900	1.32	LGY1H392MELB25
4700	22 × 45	2100	1.45	LGY1H472MELZ45
	25 × 35	2100	1.45	LGY1H472MELA35
	30 × 30	2100	1.45	LGY1H472MELB30
5600	22 × 50	2300	1.58	LGY1H562MELZ50
	25 × 40	2300	1.58	LGY1H562MELA40
	30 × 30	2300	1.58	LGY1H562MELB30
6800	25 × 45	2500	1.74	LGY1H682MELA45
	30 × 35	2500	1.74	LGY1H682MELB35
	35 × 30	2500	1.74	LGY1H682MELC30
8200	30 × 40	2800	1.92	LGY1H822MELB40
	35 × 35	2800	1.92	LGY1H822MELC35
10000	30 × 50	3100	2.12	LGY1H103MELB50
	35 × 40	3100	2.12	LGY1H103MELC40
12000	35 × 45	3400	2.32	LGY1H123MELC45
15000	35 × 50	3800	2.59	LGY1H153MELC50

Rated ripple current (mArms) at 105°C 120Hz

## LGY

### ■ Dimensions

63V (1J)				
Cap. (μF)	Size φD × L (mm)	Rated ripple (mA <sub>rms</sub> )	Leakage Current (mA)	Code
1200	22 × 25	1300	0.82	LGY1J122MELZ25
1500	22 × 30	1500	0.92	LGY1J152MELZ30
	25 × 25	1500	0.92	LGY1J152MELA25
1800	22 × 30	1600	1.01	LGY1J182MELZ30
	25 × 25	1600	1.01	LGY1J182MELA25
2200	22 × 35	1800	1.11	LGY1J222MELZ35
	25 × 30	1800	1.11	LGY1J222MELA30
2700	22 × 40	2000	1.23	LGY1J272MELZ40
	25 × 35	2000	1.23	LGY1J272MELA35
	30 × 25	2000	1.23	LGY1J272MELB25
3300	22 × 45	2200	1.36	LGY1J332MELZ45
	25 × 35	2200	1.36	LGY1J332MELA35
	30 × 30	2200	1.36	LGY1J332MELB30
3900	25 × 40	2400	1.48	LGY1J392MELA40
	30 × 35	2400	1.48	LGY1J392MELB35
4700	25 × 50	2600	1.63	LGY1J472MELA50
	30 × 40	2600	1.63	LGY1J472MELB40
	35 × 30	2600	1.63	LGY1J472MELC30
5600	30 × 45	2800	1.78	LGY1J562MELB45
	35 × 35	2800	1.78	LGY1J562MELC35
6800	30 × 50	3100	1.96	LGY1J682MELB50
	35 × 40	3100	1.96	LGY1J682MELC40
8200	35 × 45	3400	2.15	LGY1J822MELC45
10000	35 × 50	3800	2.38	LGY1J103MELC50

80V (1K)				
Cap. (μF)	Size φD × L (mm)	Rated ripple (mA <sub>rms</sub> )	Leakage Current (mA)	Code
820	22 × 25	1200	0.76	LGY1K821MELZ25
1000	22 × 25	1300	0.84	LGY1K102MELZ25
1200	22 × 30	1500	0.92	LGY1K122MELZ30
	25 × 25	1500	0.92	LGY1K122MELA25
1500	22 × 35	1600	1.03	LGY1K152MELZ35
	25 × 25	1600	1.03	LGY1K152MELA25
1800	22 × 35	1800	1.13	LGY1K182MELZ35
	25 × 30	1800	1.13	LGY1K182MELA30
	30 × 25	1800	1.13	LGY1K182MELB25
2200	22 × 45	2000	1.25	LGY1K222MELZ45
	25 × 35	2000	1.25	LGY1K222MELA35
	30 × 25	2000	1.25	LGY1K222MELB25
2700	25 × 40	2200	1.39	LGY1K272MELA40
	30 × 30	2200	1.39	LGY1K272MELB30
3300	25 × 45	2400	1.54	LGY1K332MELA45
	30 × 35	2400	1.54	LGY1K332MELB35
	35 × 30	2400	1.54	LGY1K332MELC30
3900	30 × 40	2600	1.67	LGY1K392MELB40
	35 × 30	2600	1.67	LGY1K392MELC30
4700	30 × 45	2900	1.83	LGY1K472MELB45
	35 × 35	2900	1.83	LGY1K472MELC35
5600	35 × 40	3100	2.00	LGY1K562MELC40
6800	35 × 45	3500	2.21	LGY1K682MELC45

100V (2A)				
Cap. (μF)	Size φD × L (mm)	Rated ripple (mA <sub>rms</sub> )	Leakage Current (mA)	Code
560	22 × 25	1100	0.70	LGY2A561MELZ25
680	22 × 30	1200	0.78	LGY2A681MELZ30
820	22 × 30	1300	0.85	LGY2A821MELZ30
	25 × 25	1300	0.85	LGY2A821MELA25
1000	22 × 35	1500	0.94	LGY2A102MELZ35
	25 × 30	1500	0.94	LGY2A102MELA30
1200	22 × 40	1600	1.03	LGY2A122MELZ40
	25 × 35	1600	1.03	LGY2A122MELA35
	30 × 25	1600	1.03	LGY2A122MELB25
1500	22 × 45	1800	1.16	LGY2A152MELZ45
	25 × 40	1800	1.16	LGY2A152MELA40
	30 × 30	1800	1.16	LGY2A152MELB30
1800	25 × 45	2000	1.27	LGY2A182MELA45
	30 × 35	2000	1.27	LGY2A182MELB35
2200	25 × 50	2200	1.40	LGY2A222MELA50
	30 × 40	2200	1.40	LGY2A222MELB40
	35 × 30	2200	1.40	LGY2A222MELC30
2700	30 × 45	2400	1.55	LGY2A272MELB45
	35 × 35	2400	1.55	LGY2A272MELC35
3300	30 × 50	2700	1.72	LGY2A332MELB50
	35 × 40	2700	1.72	LGY2A332MELC40
3900	35 × 45	2900	1.87	LGY2A392MELC45
4700	35 × 50	3200	2.05	LGY2A472MELC50

Rated ripple current (mA<sub>rms</sub>) at 105°C 120Hz

# ALUMINUM ELECTROLYTIC CAPACITORS

# LGR

Snap-in Terminal Type, 105°C Long Life Assurance



- Long life assurance series withstanding 10000 hours application of ripple current at 105°C.
- Compliant of the RoHS directive (2011/65/EU,(EU)2015/863).

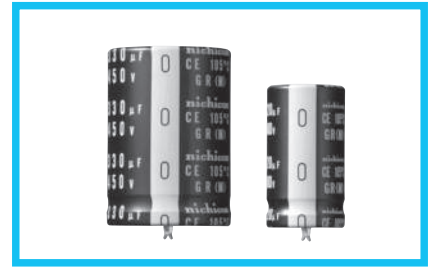

## Specifications

Item	Performance Characteristics	
Category Temperature Range	- 40 to +105°C (200 · 250V) , - 25 to +105°C (400 · 450V)	
Rated Voltage Range	200 to 450V	
Rated Capacitance Range	39 to 1500μF	
Capacitance Tolerance	±20% at 120Hz, 20°C	
Leakage Current	$I \leq 3\sqrt{CV}$ (μA) (After 5 minutes' application of rated voltage) [C : Rated Capacitance (μF) V : Voltage (V)]	
Tangent of loss angle (tan δ)	Measurement frequency : 120Hz at 20°C	
	Rated voltage(V)	200 to 400      450
	tan δ (MAX.)	0.15      0.20
Stability at Low Temperature	Measurement frequency : 120Hz	
	Rated voltage (V)	
	Impedance ratio	Z-25°C/Z+20°C      3      8
	ZT/Z20 (MAX.)	Z-40°C/Z+20°C      12      —
Endurance	The specifications listed at right shall be met when the capacitors are restored to 20°C after D.C. bias plus rated ripple current is applied for 10000 hours at 105°C, the peak voltage shall not exceed the rated voltage.	
	Capacitance change	Within ±25% of the initial capacitance value
	tan δ	250% or less than the initial specified value
Shelf Life	After storing the capacitors under no load at 105°C for 1000 hours and then performing voltage treatment based on JIS C 5101-4 clause 4.1 at 20°C, they shall meet the requirements listed at right.	
	Capacitance change	Within ±15% of the initial capacitance value
	tan δ	150% or less than the initial specified value
Marking	Printed with white color letter on black sleeve.	
	Leakage current	Less than or equal to the initial specified value

## Drawing

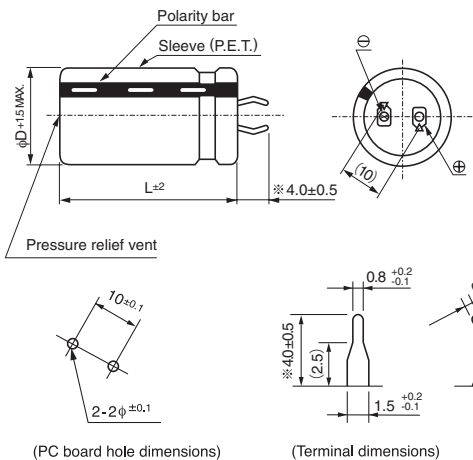

## Type numbering system (Example : 400V 120μF)

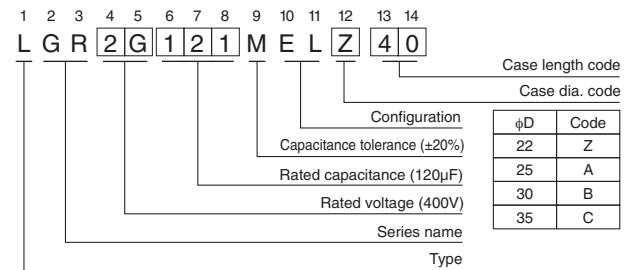

\* Other terminations available upon request.  
Please refer to the Guidelines for Aluminum Electrolytic Capacitors.

## Frequency coefficient of rated ripple current

Frequency (Hz)	50	60	120	300	1k	10k	50k or more
Coeff.	200·250V	0.81	0.85	1.00	1.17	1.32	1.45
	400·450V	0.77	0.82	1.00	1.16	1.30	1.43

Minimum order quantity : 50pcs.

● Dimension table in next page.



## ■ Dimensions

200V (2D)				
Cap. (μF)	Size φD × L (mm)	Rated ripple (mArms)	Leakage Current (mA)	Code
220	22 × 25	1000	0.62	LGR2D221MELZ25
270	22 × 30	1100	0.69	LGR2D271MELZ30
	25 × 25	1100	0.69	LGR2D271MELA25
330	22 × 30	1200	0.77	LGR2D331MELZ30
	25 × 25	1200	0.77	LGR2D331MELA25
390	22 × 35	1300	0.83	LGR2D391MELZ35
	25 × 30	1300	0.83	LGR2D391MELA30
	30 × 25	1300	0.83	LGR2D391MELB25
470	22 × 40	1400	0.91	LGR2D471MELZ40
	25 × 35	1400	0.91	LGR2D471MELA35
	30 × 30	1400	0.91	LGR2D471MELB30
560	22 × 45	1500	1.00	LGR2D561MELZ45
	25 × 35	1500	1.00	LGR2D561MELA35
	30 × 30	1500	1.00	LGR2D561MELB30
680	25 × 40	1700	1.10	LGR2D681MELA40
	30 × 35	1700	1.10	LGR2D681MELB35
820	25 × 50	2000	1.21	LGR2D821MELA50
	30 × 40	2000	1.21	LGR2D821MELB40
	35 × 30	2000	1.21	LGR2D821MELC30
1000	30 × 45	2200	1.34	LGR2D102MELB45
	35 × 35	2200	1.34	LGR2D102MELC35
1200	30 × 50	2300	1.46	LGR2D122MELB50
	35 × 40	2300	1.46	LGR2D122MELC40
1500	35 × 50	2500	1.64	LGR2D152MELC50

250V (2E)				
Cap. (μF)	Size φD × L (mm)	Rated ripple (mArms)	Leakage Current (mA)	Code
180	22 × 30	900	0.63	LGR2E181MELZ30
	25 × 25	900	0.63	LGR2E181MELA25
220	22 × 30	1000	0.70	LGR2E221MELZ30
	25 × 25	1000	0.70	LGR2E221MELA25
270	22 × 35	1100	0.77	LGR2E271MELZ35
	25 × 30	1100	0.77	LGR2E271MELA30
	30 × 25	1100	0.77	LGR2E271MELB25
330	22 × 40	1200	0.86	LGR2E331MELZ40
	25 × 35	1200	0.86	LGR2E331MELA35
	30 × 25	1200	0.86	LGR2E331MELB25
390	22 × 45	1300	0.93	LGR2E391MELZ45
	25 × 35	1300	0.93	LGR2E391MELA35
	30 × 30	1300	0.93	LGR2E391MELB30
470	25 × 45	1400	1.02	LGR2E471MELA45
	30 × 35	1400	1.02	LGR2E471MELB35
	35 × 30	1400	1.02	LGR2E471MELC30
560	25 × 50	1500	1.12	LGR2E561MELA50
	30 × 35	1500	1.12	LGR2E561MELB35
	35 × 30	1500	1.12	LGR2E561MELC30
680	30 × 45	1700	1.23	LGR2E681MELB45
	35 × 35	1700	1.23	LGR2E681MELC35
820	30 × 50	2000	1.35	LGR2E821MELB50
	35 × 40	2000	1.35	LGR2E821MELC40
	1000	35 × 45	2200	1.50
1200	35 × 50	2300	1.64	LGR2E122MELC50

400V (2G)				
Cap. (μF)	Size φD × L (mm)	Rated ripple (mArms)	Leakage Current (mA)	Code
56	22 × 25	510	0.44	LGR2G560MELZ25
68	22 × 30	560	0.49	LGR2G680MELZ30
	25 × 25	560	0.49	LGR2G680MELA25
82	22 × 35	640	0.54	LGR2G820MELZ35
	25 × 25	640	0.54	LGR2G820MELA25
100	22 × 35	690	0.60	LGR2G101MELZ35
	25 × 30	690	0.60	LGR2G101MELA30
120	22 × 40	750	0.65	LGR2G121MELZ40
	25 × 35	750	0.65	LGR2G121MELA35
	30 × 25	750	0.65	LGR2G121MELB25
150	22 × 50	820	0.73	LGR2G151MELZ50
	25 × 40	820	0.73	LGR2G151MELA40
	30 × 30	820	0.73	LGR2G151MELB30
180	25 × 45	900	0.80	LGR2G181MELA45
	30 × 35	900	0.80	LGR2G181MELB35
	35 × 25	900	0.80	LGR2G181MELC25
220	25 × 50	1000	0.88	LGR2G221MELA50
	30 × 40	1000	0.88	LGR2G221MELB40
270	30 × 45	1100	0.98	LGR2G271MELB45
	35 × 35	1100	0.98	LGR2G271MELC35
330	30 × 50	1200	1.08	LGR2G331MELB50
	35 × 40	1200	1.08	LGR2G331MELC40
390	35 × 45	1300	1.18	LGR2G391MELC45
470	35 × 50	1400	1.30	LGR2G471MELC50

450V (2W)				
Cap. (μF)	Size φD × L (mm)	Rated ripple (mArms)	Leakage Current (mA)	Code
39	22 × 25	370	0.39	LGR2W390MELZ25
47	22 × 30	400	0.43	LGR2W470MELZ30
	22 × 35	470	0.47	LGR2W560MELZ35
56	25 × 25	470	0.47	LGR2W560MELA25
	22 × 40	530	0.52	LGR2W680MELZ40
68	25 × 30	530	0.52	LGR2W680MELA30
	22 × 45	560	0.57	LGR2W820MELZ45
82	25 × 35	560	0.57	LGR2W820MELA35
	30 × 25	560	0.57	LGR2W820MELB25
	22 × 50	640	0.63	LGR2W101MELZ50
100	25 × 40	640	0.63	LGR2W101MELA40
	30 × 30	640	0.63	LGR2W101MELB30
120	25 × 45	720	0.69	LGR2W121MELA45
	30 × 30	720	0.69	LGR2W121MELB30
150	25 × 50	790	0.77	LGR2W151MELA50
	30 × 40	790	0.77	LGR2W151MELB40
	35 × 30	790	0.77	LGR2W151MELC30
180	30 × 45	870	0.85	LGR2W181MELB45
	35 × 35	870	0.85	LGR2W181MELC35
220	30 × 50	1000	0.94	LGR2W221MELB50
	35 × 40	1000	0.94	LGR2W221MELC40
270	35 × 45	1190	1.04	LGR2W271MELC45
330	35 × 50	1380	1.15	LGR2W331MELC50

Rated ripple current (mArms) at 105°C 120Hz



# ALUMINUM ELECTROLYTIC CAPACITORS

**LGZ** Snap-in Terminal Type, 105°C Long Life Assurance



- Long life product of LGR series.
- Contribute to longer life of equipment.
- Compliant to the RoHS directive (2011/65/EU, (EU)2015/863).



## Specifications

Item	Performance Characteristics							
Category Temperature Range	- 25 to +105°C							
Rated Voltage Range	450V							
Rated Capacitance Range	82 to 330μF							
Capacitance Tolerance	±20% at 120Hz, 20°C							
Leakage Current	After 5 minutes' application of rated voltage at 20°C, leakage current is not more than $3\sqrt{CV}$ (μA) or 5 mA, whichever is smaller (at 20°C) [C : Rated Capacitance (μF) , V : Voltage (V)]							
Tangent of loss angle (tan δ)	0.20MAX. 120Hz at 20°C							
Stability at Low Temperature	Rated voltage (V)	450						
	Impedance ratio ZT/Z20(MAX.)	Z - 25°C / Z+20°C 8						
Endurance	The specifications listed at right shall be met when the capacitors are restored to 20°C after D.C. bias plus rated ripple current is applied for 20000 hours at 105°C, the peak voltage shall not exceed the rated voltage.	<table border="1"> <tr> <td>Capacitance change</td> <td>Within ±25% of the initial capacitance value</td> </tr> <tr> <td>tan δ</td> <td>250% or less than the initial specified value</td> </tr> <tr> <td>Leakage current</td> <td>Less than or equal to the initial specified value</td> </tr> </table>	Capacitance change	Within ±25% of the initial capacitance value	tan δ	250% or less than the initial specified value	Leakage current	Less than or equal to the initial specified value
	Capacitance change	Within ±25% of the initial capacitance value						
	tan δ	250% or less than the initial specified value						
Leakage current	Less than or equal to the initial specified value							
Shelf Life	After storing the capacitors under no load at 105°C for 1000 hours and then performing voltage treatment based on JIS C 5101-4 clause 4.1 at 20°C, they shall meet the characteristic requirements listed at right.	<table border="1"> <tr> <td>Capacitance change</td> <td>Within ±15% of the initial capacitance value</td> </tr> <tr> <td>tan δ</td> <td>150% or less than the initial specified value</td> </tr> <tr> <td>Leakage current</td> <td>Less than or equal to the initial specified value</td> </tr> </table>	Capacitance change	Within ±15% of the initial capacitance value	tan δ	150% or less than the initial specified value	Leakage current	Less than or equal to the initial specified value
	Capacitance change	Within ±15% of the initial capacitance value						
	tan δ	150% or less than the initial specified value						
Leakage current	Less than or equal to the initial specified value							
Marking	Printed with white color letter on black sleeve.							

## Drawing

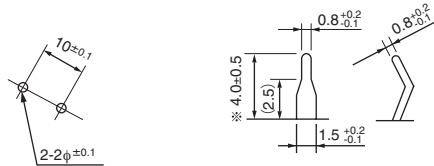
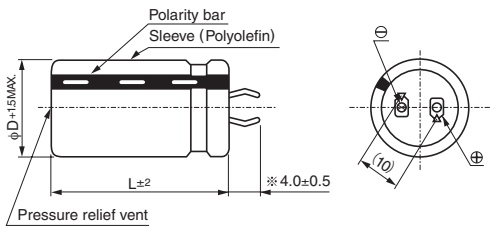

(PC board hole dimensions)

(Terminal dimensions)

※ Other terminations available upon request. Please refer to the Guidelines for Aluminum Electrolytic Capacitors.

## Type numbering system (Example : 450V 82μF)

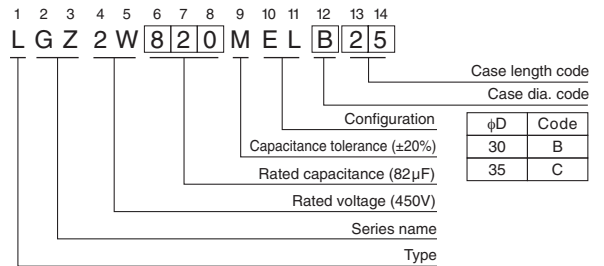

## Dimensions

450V (2W)				
Cap. (μF)	Size φD x L(mm)	Rated ripple (mArms)	Leakage Current (mA)	Code
82	30 x 25	560	0.57	LGZ2W820MELB25
100	30 x 30	640	0.63	LGZ2W101MELB30
120	30 x 35	720	0.69	LGZ2W121MELB35
	35 x 25	720	0.69	LGZ2W121MELC25
150	30 x 40	790	0.77	LGZ2W151MELB40
	35 x 30	790	0.77	LGZ2W151MELC30
180	30 x 45	870	0.85	LGZ2W181MELB45
	35 x 35	870	0.85	LGZ2W181MELC35
220	30 x 50	1000	0.94	LGZ2W221MELB50
	35 x 40	1000	0.94	LGZ2W221MELC40
270	35 x 45	1190	1.04	LGZ2W271MELC45
330	35 x 50	1380	1.15	LGZ2W331MELC50

Rated ripple current (mArms) at 105°C 120Hz

## Frequency coefficient of rated ripple current

Frequency (Hz)	50	60	120	300	1 k	10k	50k or more
Coefficient	0.77	0.82	1.00	1.16	1.30	1.41	1.43

Minimum order quantity : 50pcs.

# ALUMINUM ELECTROLYTIC CAPACITORS

# LGX

Snap-in Terminal Type,  
105°C Long Life Assurance, Smaller-Sized



- Long life assurance series withstanding 5000 hours application of rated ripple current at 105°C.
- Suited for rectifier circuit of general inverter, switching power supply.
- Addition of 500V rated voltage.
- Compliant to the RoHS directive (2011/65/EU,(EU)2015/863).



## LGX

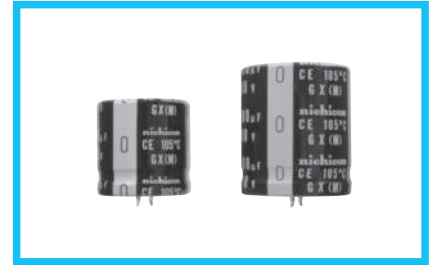

### Specifications

Item	Performance Characteristics			
Category Temperature Range	-25 to +105°C			
Rated Voltage Range	200 to 500V			
Rated Capacitance Range	56 to 2200μF			
Capacitance Tolerance	±20% at 120Hz, 20°C			
Leakage Current	$I \leq 3\sqrt{CV}$ (μA) (After 5 minutes' application of rated voltage) [C : Rated Capacitance (μF) V : Voltage (V)]			
Tangent of loss angle (tan δ)	Rated voltage(V)	200 to 400      450 to 500	Measurement frequency : 120Hz at 20°C	
	tan δ (MAX.)	0.15      0.20		
Stability at Low Temperature	Rated voltage(V)	200 · 250      400 to 500	Measurement frequency : 120Hz	
	Impedance ratio (MAX.)	Z-25°C/Z+20°C      4      8		
Endurance	The specifications listed at right shall be met when the capacitors are restored to 20°C after D.C. bias plus rated ripple current is applied for 5000 hours at 105°C, the peak voltage shall not exceed the rated voltage.		Capacitance change	Within ±20% of the initial capacitance value
			tan δ	200% or less than the initial specified value
			Leakage current	Less than or equal to the initial specified value
Shelf Life	After storing the capacitors under no load at 105°C for 1000 hours and then performing voltage treatment based on JIS C 5101-4 clause 4.1 at 20°C, they shall meet the requirements listed at right.		Capacitance change	Within ±15% of the initial capacitance value
			tan δ	150% or less than the initial specified value
			Leakage current	Less than or equal to the initial specified value
Marking	Printed with white color letter on black sleeve.			

### Drawing

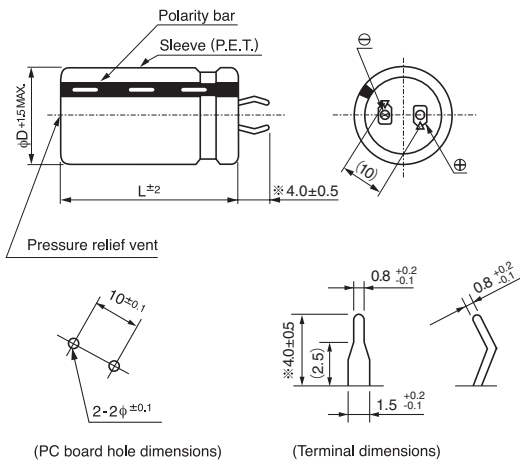

### Type numbering system (Example : 400V 120μF)

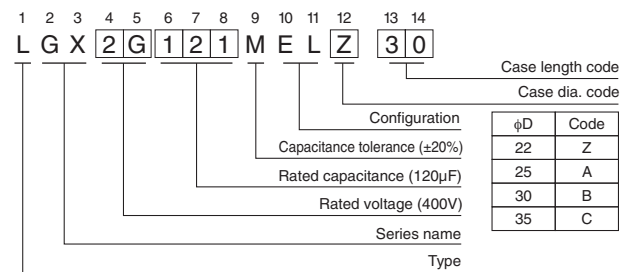

\* Other terminations available upon request.  
Please refer to the Guidelines for Aluminum Electrolytic Capacitors.

Minimum order quantity : 50pcs.

● Dimension table in next page.



## ■ Dimensions

200V (2D)				
Cap. (μF)	Size φD × L(mm)	Rated ripple (mArms)	Leakage Current (mA)	Code
330	22 × 25	1100	0.77	LGX2D331MELZ25
390	22 × 30	1380	0.83	LGX2D391MELZ30
470	22 × 35	1550	0.91	LGX2D471MELZ35
	25 × 25	1390	0.91	LGX2D471MELA25
560	22 × 35	1550	1.00	LGX2D561MELZ35
680	22 × 40	1730	1.10	LGX2D681MELZ40
	25 × 35	1870	1.10	LGX2D681MELA35
	30 × 30	1980	1.10	LGX2D681MELB30
820	22 × 50	2180	1.21	LGX2D821MELZ50
	25 × 40	2090	1.21	LGX2D821MELA40
1000	25 × 45	2350	1.34	LGX2D102MELA45
	30 × 35	2220	1.34	LGX2D102MELB35
	35 × 30	2610	1.34	LGX2D102MELC30
1200	25 × 50	2400	1.46	LGX2D122MELA50
	30 × 40	2530	1.46	LGX2D122MELB40
	35 × 35	2880	1.46	LGX2D122MELC35
1500	30 × 50	3000	1.64	LGX2D152MELB50
	35 × 40	3080	1.64	LGX2D152MELC40
1800	35 × 45	3280	1.80	LGX2D182MELC45
2200	35 × 50	3450	1.98	LGX2D222MELC50

250V (2E)				
Cap. (μF)	Size φD × L(mm)	Rated ripple (mArms)	Leakage Current (mA)	Code
270	22 × 25	1010	0.77	LGX2E271MELZ25
330	22 × 30	1200	0.86	LGX2E331MELZ30
	25 × 25	1320	0.86	LGX2E331MELA25
390	22 × 35	1440	0.93	LGX2E391MELZ35
	25 × 30	1430	0.93	LGX2E391MELA30
470	22 × 40	1620	1.02	LGX2E471MELZ40
	25 × 35	1600	1.02	LGX2E471MELA35
	30 × 25	1510	1.02	LGX2E471MELB25
560	22 × 45	1800	1.12	LGX2E561MELZ45
	25 × 35	1780	1.12	LGX2E561MELA35
	30 × 30	1830	1.12	LGX2E561MELB30
680	22 × 50	2000	1.23	LGX2E681MELZ50
	25 × 40	2000	1.23	LGX2E681MELA40
	30 × 35	2060	1.23	LGX2E681MELB35
	35 × 25	1910	1.23	LGX2E681MELC25
820	25 × 45	2150	1.35	LGX2E821MELA45
	30 × 35	2060	1.35	LGX2E821MELB35
	35 × 30	2150	1.35	LGX2E821MELC30
1000	30 × 40	2330	1.50	LGX2E102MELB40
	35 × 35	2380	1.50	LGX2E102MELC35
1200	30 × 50	2680	1.64	LGX2E122MELB50
	35 × 40	2720	1.64	LGX2E122MELC40
1500	35 × 45	3050	1.83	LGX2E152MELC45
1800	35 × 50	3300	2.01	LGX2E182MELC50

400V (2G)				
Cap. (μF)	Size φD × L(mm)	Rated ripple (mArms)	Leakage Current (mA)	Code
100	22 × 25	660	0.60	LGX2G101MELZ25
120	22 × 30	750	0.65	LGX2G121MELZ30
150	22 × 35	860	0.73	LGX2G151MELZ35
	25 × 25	860	0.73	LGX2G151MELA25
180	22 × 35	860	0.80	LGX2G181MELZ35
	25 × 30	970	0.80	LGX2G181MELA30
220	30 × 25	1020	0.80	LGX2G181MELB25
	22 × 45	1090	0.88	LGX2G221MELZ45
270	25 × 35	1120	0.88	LGX2G221MELA35
	22 × 50	1230	0.98	LGX2G271MELZ50
330	25 × 40	1260	0.98	LGX2G271MELA40
	30 × 30	1270	0.98	LGX2G271MELB30
	35 × 25	1220	0.98	LGX2G271MELC25
	25 × 45	1300	1.08	LGX2G331MELA45
390	30 × 35	1430	1.08	LGX2G331MELB35
	25 × 50	1440	1.18	LGX2G391MELA50
470	30 × 40	1600	1.18	LGX2G391MELB40
	35 × 30	1520	1.18	LGX2G391MELC30
560	30 × 45	1810	1.30	LGX2G471MELB45
	35 × 35	1670	1.30	LGX2G471MELC35
680	35 × 40	1900	1.41	LGX2G561MELC40
820	35 × 45	2120	1.56	LGX2G681MELC45

450V (2W)				
Cap. (μF)	Size φD × L(mm)	Rated ripple (mArms)	Leakage Current (mA)	Code
82	22 × 25	590	0.57	LGX2W820MELZ25
100	22 × 30	690	0.63	LGX2W101MELZ30
	25 × 25	700	0.63	LGX2W101MELA25
120	22 × 35	770	0.69	LGX2W121MELZ35
	25 × 30	880	0.69	LGX2W121MELA30
150	22 × 40	880	0.77	LGX2W151MELZ40
	25 × 30	880	0.77	LGX2W151MELA30
	30 × 25	930	0.77	LGX2W151MELB25
180	22 × 45	900	0.85	LGX2W181MELZ45
	25 × 35	920	0.85	LGX2W181MELA35
	30 × 30	1030	0.85	LGX2W181MELB30
	35 × 25	1100	0.85	LGX2W181MELC25
220	25 × 40	1030	0.94	LGX2W221MELA40
	30 × 35	1170	0.94	LGX2W221MELB35
	35 × 25	1100	0.94	LGX2W221MELC25
270	25 × 50	1310	1.04	LGX2W271MELA50
	30 × 40	1330	1.04	LGX2W271MELB40
	35 × 30	1240	1.04	LGX2W271MELC30
330	30 × 45	1510	1.15	LGX2W331MELB45
	35 × 35	1390	1.15	LGX2W331MELC35
390	30 × 50	1670	1.25	LGX2W391MELB50
	35 × 40	1730	1.25	LGX2W391MELC40
470	35 × 45	1830	1.37	LGX2W471MELC45
560	35 × 50	1980	1.50	LGX2W561MELC50

Rated ripple current (mArms) at 105°C 120Hz

LGX

## ■ Dimensions

500V (2H)				
Cap. ( $\mu$ F)	Size $\phi$ D x L(mm)	Rated ripple (mA <sub>rms</sub> )	Leakage Current (mA)	Code
56	22 x 25	560	0.50	LGX2H560MELZ25
68	22 x 30	590	0.55	LGX2H680MELZ30
	25 x 25	650	0.55	LGX2H680MELA25
82	22 x 35	720	0.60	LGX2H820MELZ35
	25 x 30	740	0.60	LGX2H820MELA30
100	22 x 40	770	0.67	LGX2H101MELZ40
120	22 x 50	930	0.73	LGX2H121MELZ50
	25 x 35	930	0.73	LGX2H121MELA35
	30 x 25	820	0.73	LGX2H121MELB25
150	25 x 45	1080	0.82	LGX2H151MELA45
	30 x 30	910	0.82	LGX2H151MELB30
	35 x 25	990	0.82	LGX2H151MELC25
180	25 x 50	1200	0.90	LGX2H181MELA50
	30 x 35	1040	0.90	LGX2H181MELB35
	35 x 30	1100	0.90	LGX2H181MELC30
220	30 x 45	1330	0.99	LGX2H221MELB45
	35 x 35	1230	0.99	LGX2H221MELC35
270	30 x 50	1500	1.10	LGX2H271MELB50
	35 x 40	1420	1.10	LGX2H271MELC40
330	35 x 45	1600	1.21	LGX2H331MELC45
390	35 x 50	1780	1.32	LGX2H391MELC50
470	35 x 58	2030	1.45	LGX2H471MELC58

Rated ripple current (mA<sub>rms</sub>) at 105°C 120Hz

## ● Frequency coefficient of rated ripple current

Frequency (Hz)		50	60	120	300	1k	10k	50k or more
Coeff.	200・250V	0.81	0.85	1.00	1.17	1.32	1.45	1.50
	400 to 500V	0.77	0.82	1.00	1.16	1.30	1.41	1.43

Minimum order quantity : 50pcs.

# LGW

Snap-in Terminal Type, 105°C High Ripple Current



- High Ripple current.
- Withstanding 3000 hours application of rated ripple current at 105°C.
- Compliant to the RoHS directive (2011/65/EU,(EU)2015/863).

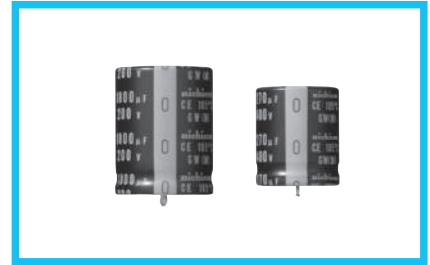
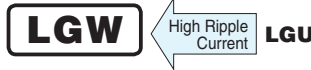

## Specifications

Item	Performance Characteristics		
Category Temperature Range	- 40 to +105°C (200 · 250V) , - 25 to +105°C (400 · 450V)		
Rated Voltage Range	200 to 450V		
Rated Capacitance Range	82 to 2200μF		
Capacitance Tolerance	±20% at 120Hz, 20°C		
Leakage Current	$I \leq 3 \cdot \sqrt{CV}$ (μA) (After 5 minutes' application of rated voltage) [C : Rated Capacitance (μF) V : Voltage (V)]		
Tangent of loss angle (tan δ)	Rated voltage(V)	200 to 400	450
	tan δ (MAX.)	0.15	0.20
Stability at Low Temperature	Measurement frequency : 120Hz		
	Rated voltage(V)		
	Impedance ratio	Z-25°C/Z+20°C	200 · 250
Endurance	The specifications listed at right shall be met when the capacitors are restored to 20°C after D.C. bias plus rated ripple current is applied for 3000 hours at 105°C, the peak voltage shall not exceed the rated voltage.		
	Capacitance change	Within ±20% of the initial capacitance value	
	tan δ	200% or less than the initial specified value	
Shelf Life	After storing the capacitors under no load at 105°C for 1000 hours and then performing voltage treatment based on JIS C 5101-4 clause 4.1 at 20°C, they shall meet the requirements listed at right.		
	Capacitance change	Within ±15% of the initial capacitance value	
	tan δ	150% or less than the initial specified value	
Marking	Printed with white color letter on black sleeve.		

## Drawing

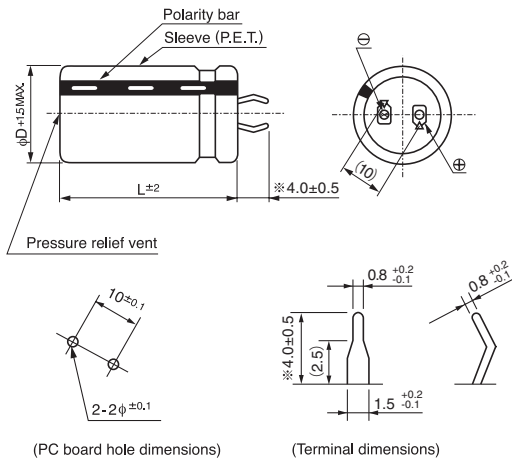

## Type numbering system (Example : 400V 120μF)

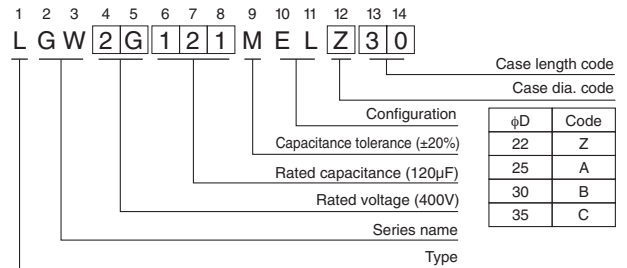

※ Other terminations available upon request.  
Please refer to the Guidelines for Aluminum Electrolytic Capacitors.

## Frequency coefficient of rated ripple current

Frequency (Hz)	50	60	120	300	1k	10k	50k or more
Coeff.	0.81	0.85	1.00	1.17	1.32	1.45	1.50
	0.77	0.82	1.00	1.16	1.30	1.41	1.43

Minimum order quantity : 50pcs.

● Dimension table in next page.

## LGW

### ■ Dimensions

200V (2D)				
Cap. (μF)	Size φD × L(mm)	Rated ripple (mA <sub>rms</sub> )	Leakage Current (mA)	Code
330	22 × 25	1970	0.77	LGW2D331MELZ25
470	22 × 30	2170	0.91	LGW2D471MELZ30
	25 × 25	2170	0.91	LGW2D471MELA25
560	22 × 35	2220	1.00	LGW2D561MELZ35
	25 × 30	2300	1.00	LGW2D561MELA30
680	22 × 40	2300	1.10	LGW2D681MELZ40
	25 × 35	2650	1.10	LGW2D681MELA35
	30 × 25	3080	1.10	LGW2D681MELB25
820	22 × 45	2650	1.21	LGW2D821MELZ45
	25 × 40	3080	1.21	LGW2D821MELA40
	30 × 30	3480	1.21	LGW2D821MELB30
	35 × 25	3480	1.21	LGW2D821MELC25
1000	25 × 45	3450	1.34	LGW2D102MELA45
	30 × 35	3980	1.34	LGW2D102MELB35
1200	25 × 50	3980	1.46	LGW2D122MELA50
	30 × 40	4200	1.46	LGW2D122MELB40
	35 × 30	4200	1.46	LGW2D122MELC30
1500	30 × 45	4620	1.64	LGW2D152MELB45
	35 × 35	4200	1.64	LGW2D152MELC35
1800	30 × 50	5220	1.80	LGW2D182MELB50
	35 × 40	4620	1.80	LGW2D182MELC40
2200	35 × 45	5220	1.98	LGW2D222MELC45

250V (2E)				
Cap. (μF)	Size φD × L(mm)	Rated ripple (mA <sub>rms</sub> )	Leakage Current (mA)	Code
270	22 × 25	1650	0.77	LGW2E271MELZ25
330	22 × 30	1800	0.86	LGW2E331MELZ30
	25 × 25	1800	0.86	LGW2E331MELA25
390	22 × 35	1950	0.93	LGW2E391MELZ35
	25 × 30	1950	0.93	LGW2E391MELA30
470	22 × 40	2100	1.02	LGW2E471MELZ40
	30 × 25	2200	1.02	LGW2E471MELB25
560	22 × 45	2250	1.12	LGW2E561MELZ45
	25 × 35	2250	1.12	LGW2E561MELA35
680	22 × 50	2550	1.23	LGW2E681MELZ50
	25 × 40	2550	1.23	LGW2E681MELA40
	30 × 30	2550	1.23	LGW2E681MELB30
	35 × 25	2550	1.23	LGW2E681MELC25
820	25 × 50	3000	1.35	LGW2E821MELA50
	30 × 35	3000	1.35	LGW2E821MELB35
	35 × 30	3000	1.35	LGW2E821MELC30
1000	30 × 40	3300	1.50	LGW2E102MELB40
	35 × 35	3300	1.50	LGW2E102MELC35
1200	30 × 50	3450	1.64	LGW2E122MELB50
	35 × 40	3450	1.64	LGW2E122MELC40
1500	35 × 45	3750	1.83	LGW2E152MELC45
1800	35 × 50	4050	2.01	LGW2E182MELC50

400V (2G)				
Cap. (μF)	Size φD × L(mm)	Rated ripple (mA <sub>rms</sub> )	Leakage Current (mA)	Code
100	22 × 25	1020	0.60	LGW2G101MELZ25
120	22 × 30	1220	0.65	LGW2G121MELZ30
	25 × 25	1220	0.65	LGW2G121MELA25
150	22 × 35	1330	0.73	LGW2G151MELZ35
	22 × 40	1430	0.80	LGW2G181MELZ40
180	25 × 30	1430	0.80	LGW2G181MELA30
	30 × 25	1680	0.80	LGW2G181MELB25
220	22 × 45	1550	0.88	LGW2G221MELZ45
	25 × 35	1650	0.88	LGW2G221MELA35
	30 × 30	1790	0.88	LGW2G221MELB30
270	22 × 50	1680	0.98	LGW2G271MELZ50
	25 × 40	1830	0.98	LGW2G271MELA40
	30 × 35	2120	0.98	LGW2G271MELB35
	35 × 25	2120	0.98	LGW2G271MELC25
330	25 × 50	2120	1.08	LGW2G331MELA50
	30 × 40	2330	1.08	LGW2G331MELB40
	35 × 30	2330	1.08	LGW2G331MELC30
390	30 × 45	2520	1.18	LGW2G391MELB45
	35 × 35	2520	1.18	LGW2G391MELC35
470	30 × 50	2850	1.30	LGW2G471MELB50
	35 × 40	2850	1.30	LGW2G471MELC40
560	35 × 45	3180	1.41	LGW2G561MELC45
680	35 × 50	3210	1.56	LGW2G681MELC50

450V (2W)				
Cap. (μF)	Size φD × L(mm)	Rated ripple (mA <sub>rms</sub> )	Leakage Current (mA)	Code
82	22 × 25	960	0.57	LGW2W820MELZ25
100	22 × 30	1040	0.63	LGW2W101MELZ30
	25 × 25	1040	0.63	LGW2W101MELA25
120	22 × 35	1150	0.69	LGW2W121MELZ35
	25 × 30	1220	0.69	LGW2W121MELA30
150	22 × 40	1220	0.77	LGW2W151MELZ40
	25 × 35	1310	0.77	LGW2W151MELA35
	30 × 25	1310	0.77	LGW2W151MELB25
180	22 × 45	1350	0.85	LGW2W181MELZ45
	25 × 40	1350	0.85	LGW2W181MELA40
	30 × 30	1600	0.85	LGW2W181MELB30
	35 × 25	1600	0.85	LGW2W181MELC25
220	25 × 45	1550	0.94	LGW2W221MELA45
	30 × 35	1710	0.94	LGW2W221MELB35
270	25 × 50	1740	1.04	LGW2W271MELA50
	30 × 40	1900	1.04	LGW2W271MELB40
	35 × 30	1900	1.04	LGW2W271MELC30
330	30 × 45	2200	1.15	LGW2W331MELB45
	35 × 35	2200	1.15	LGW2W331MELC35
390	30 × 50	2400	1.25	LGW2W391MELB50
	35 × 40	2420	1.25	LGW2W391MELC40
470	35 × 45	2670	1.37	LGW2W471MELC45
560	35 × 50	2850	1.50	LGW2W561MELC50

Rated ripple current (mA<sub>rms</sub>) at 105°C 120Hz

# ALUMINUM ELECTROLYTIC CAPACITORS



# LAK

Snap-in Terminal Type, 105°C Permissible Abnormal Voltage

- Withstanding 2000 hours application of rated ripple current at 105°C.
- Extended voltage range at 200V, 400V and 420V.
- Improved safety features for abnormally excessive voltage.
- Ideally suited for the equipment used at voltage fluctuating area.
- Compliant the RoHS directive (2011/65/EU,(EU)2015/863).

**LAK**

Smaller  
**LAQ**



## Specifications

Item	Performance Characteristics			
Category Temperature Range	- 25 to +105°C			
Rated Voltage Range	200 · 400 · 420V			
Rated Capacitance Range	33 to 1200μF			
Capacitance Tolerance	±20% at 120Hz, 20°C			
Leakage Current	$I \leq 3\sqrt{CV}$ (μA) (After 5 minutes' application of rated voltage) [C : Rated Capacitance (μF) V : Voltage (V)]			
Tangent of loss angle (tan δ)	0.20MAX. 120Hz at 20°C			
Stability at Low Temperature	Rated voltage(V)		200	400 · 420
	Impedance ratio (MAX)	Z - 25°C/Z+20°C	8	8
Endurance	The specifications listed at right shall be met when the capacitors are restored to 20°C after D.C. bias plus rated ripple current is applied for 2000 hours at 105°C, the peak voltage shall not exceed the rated voltage.			Measurement frequency : 120Hz
	Capacitance change	Within ±20% of the initial capacitance value		
	tan δ	200% or less than the initial specified value		
Shelf Life	After storing the capacitors under no load at 105°C for 1000 hours and then performing voltage treatment based on JIS C 5101-4 clause 4.1 at 20°C, they shall meet the requirements listed at right.			Measurement frequency : 120Hz
	Capacitance change	Within ±15% of the initial capacitance value		
	tan δ	150% or less than the initial specified value		
Safety Performance	The pressure relief vent will operate in normal conditions, with no dangerous conditions such as flames, ignitions or dispersion of pieces of the capacitor and/or case.			
	rating		test conditions	
	Voltage (V)	Capacitance (μF)	Limited DC current	Test voltage
	200	C < 330	4 A	300VDC and 375VDC
		330 ≤ C < 470	5 A	
		470 ≤ C	7 A	
400	C < 100	2 A	500VDC and 600VDC	
	100 ≤ C < 220	4 A		
	220 ≤ C	7 A		
420	C < 100	2 A	520VDC and 630VDC	
	100 ≤ C < 220	4 A		
	220 ≤ C	7 A		
Marking	Printed with white color letter on black sleeve			

## Drawing

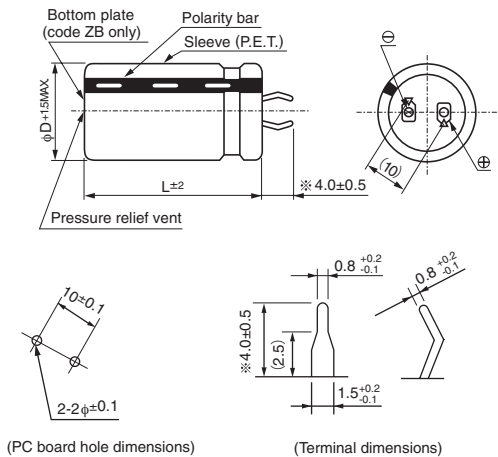

## Type numbering system (Example : 200V 680μF)

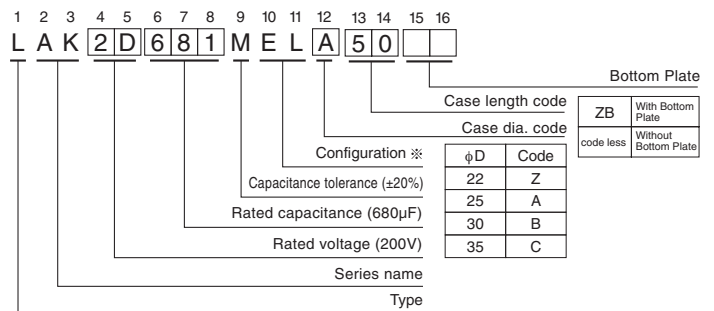

※ Please contact to us if other configurations are required.

Minimum order quantity : 50pcs.

● Dimension table in next page.

CAT.8100K

## LAK

### ■ Dimensions

200V (2D)				
Cap. (μF)	Size φD × L(mm)	Ripple (mArms)	Leakage Current (mA)	Code
47	22 × 20	350	0.29	LAK2D470MELZ20
100	22 × 20	500	0.42	LAK2D101MELZ20
150	25 × 20	650	0.51	LAK2D151MELA20
180	22 × 25	700	0.56	LAK2D181MELZ25
	30 × 20	700	0.56	LAK2D181MELB20
220	22 × 25	740	0.62	LAK2D221MELZ25
270	22 × 30	900	0.69	LAK2D271MELZ30
	25 × 25	850	0.69	LAK2D271MELA25
	35 × 20	1100	0.69	LAK2D271MELC20
330	22 × 30	1050	0.77	LAK2D331MELZ30
	25 × 30	1050	0.77	LAK2D331MELA30
	30 × 25	1050	0.77	LAK2D331MELB25
390	22 × 35	1200	0.83	LAK2D391MELZ35
	25 × 30	1200	0.83	LAK2D391MELA30
	30 × 25	1200	0.83	LAK2D391MELB25
470	22 × 40	1300	0.91	LAK2D471MELZ40
	25 × 35	1300	0.91	LAK2D471MELA35
	30 × 25	1350	0.91	LAK2D471MELB25
560	22 × 45	1500	1.00	LAK2D561MELZ45
	25 × 40	1500	1.00	LAK2D561MELA40
	30 × 35	1550	1.00	LAK2D561MELB35
	35 × 25	1550	1.00	LAK2D561MELC25
680	25 × 50	1700	1.10	LAK2D681MELA50
	30 × 40	1700	1.10	LAK2D681MELB40
	35 × 30	1700	1.10	LAK2D681MELC30
820	30 × 45	1990	1.21	LAK2D821MELB45
	35 × 35	1990	1.21	LAK2D821MELC35
1000	30 × 50	2100	1.34	LAK2D102MELB50
	35 × 40	2100	1.34	LAK2D102MELC40
1200	35 × 50	2300	1.46	LAK2D122MELC50

420V (W6)				
Cap. (μF)	Size φD × L(mm)	Ripple (mArms)	Leakage Current (mA)	Code
33	22 × 25	250	0.35	LAKW6330MELZ25
47	22 × 25	350	0.42	LAKW6470MELZ25
56	22 × 25	380	0.46	LAKW6560MELZ25
68	22 × 30	450	0.50	LAKW6680MELZ30
	25 × 25	450	0.50	LAKW6680MELA25
82	22 × 35	640	0.55	LAKW6820MELZ35
	25 × 30	640	0.55	LAKW6820MELA30
100	22 × 40	690	0.61	LAKW6101MELZ40
	25 × 30	690	0.61	LAKW6101MELA30
	30 × 25	690	0.61	LAKW6101MELB25
120	22 × 45	750	0.67	LAKW6121MELZ45
	25 × 35	750	0.67	LAKW6121MELA35
	30 × 30	750	0.67	LAKW6121MELB30
	35 × 25	750	0.67	LAKW6121MELC25
150	25 × 40	820	0.75	LAKW6151MELA40
	30 × 30	820	0.75	LAKW6151MELB30
	35 × 25	820	0.75	LAKW6151MELC25
180	25 × 45	900	0.82	LAKW6181MELA45
	30 × 35	900	0.82	LAKW6181MELB35
	35 × 30	900	0.82	LAKW6181MELC30
220	30 × 40	1000	0.91	LAKW6221MELB40
	35 × 35	1000	0.91	LAKW6221MELC35
270	30 × 45	1100	1.01	LAKW6271MELB45
	35 × 40	1100	1.01	LAKW6271MELC40
330	35 × 45	1200	1.11	LAKW6331MELC45

Rated ripple current (mArms) at 105°C 120Hz

400V (2G)				
Cap. (μF)	Size φD × L(mm)	Ripple (mArms)	Leakage Current (mA)	Code
33	22 × 20	220	0.34	LAK2G330MELZ20
39	22 × 20	300	0.37	LAK2G390MELZ20
47	22 × 25	350	0.41	LAK2G470MELZ25
	25 × 20	350	0.41	LAK2G470MELA20
	30 × 20	400	0.41	LAK2G470MELB20
56	22 × 25	380	0.44	LAK2G560MELZ25
	25 × 20	380	0.44	LAK2G560MELA20
68	22 × 25	400	0.49	LAK2G680MELZ25
	25 × 25	450	0.49	LAK2G680MELA25
	30 × 20	500	0.49	LAK2G680MELB20
82	22 × 30	500	0.54	LAK2G820MELZ30
	25 × 25	500	0.54	LAK2G820MELA25
	30 × 20	500	0.54	LAK2G820MELB20
100	22 × 35	550	0.60	LAK2G101MELZ35
	25 × 30	530	0.60	LAK2G101MELA30
	30 × 25	530	0.60	LAK2G101MELB25
	35 × 20	550	0.60	LAK2G101MELC20
120	22 × 40	600	0.65	LAK2G121MELZ40
	25 × 30	600	0.65	LAK2G121MELA30
	30 × 25	600	0.65	LAK2G121MELB25
150	22 × 45	700	0.73	LAK2G151MELZ45
	25 × 35	700	0.73	LAK2G151MELA35
	30 × 30	700	0.73	LAK2G151MELB30
	35 × 25	700	0.73	LAK2G151MELC25
180	22 × 50	800	0.80	LAK2G181MELZ50
	25 × 40	800	0.80	LAK2G181MELA40
	30 × 30	800	0.80	LAK2G181MELB30
	35 × 25	800	0.80	LAK2G181MELC25
220	25 × 45	900	0.88	LAK2G221MELA45
	30 × 35	900	0.88	LAK2G221MELB35
	35 × 30	900	0.88	LAK2G221MELC30
270	30 × 40	980	0.98	LAK2G271MELB40
	35 × 35	960	0.98	LAK2G271MELC35
330	30 × 50	1210	1.08	LAK2G331MELB50
	35 × 40	1210	1.08	LAK2G331MELC40
390	35 × 45	1320	1.18	LAK2G391MELC45
470	35 × 50	1450	1.30	LAK2G471MELC50

#### ● Frequency coefficient of rated ripple current

Coefficient	Frequency (Hz)	50	60	120	1k	10k or more
	200V		0.85	0.88	1.00	1.15
400・420V		0.88	0.90	1.00	1.10	1.15



# ALUMINUM ELECTROLYTIC CAPACITORS

# LAQ

Snap-in Terminal Type, 105°C Permissible Abnormal Voltage, Smaller-sized



- Withstanding 2000 hours application of rated ripple current of 105°C.
- Extended voltage range at 200V, 220V and 400V.
- Smaller case sizes and higher ripple current than LAK.
- Improved safety features for abnormally excessive voltage.
- Ideally suited for the equipment used at voltage fluctuating area.
- Compliant to the RoHS directive (2011/65/EU, (EU)2015/863).

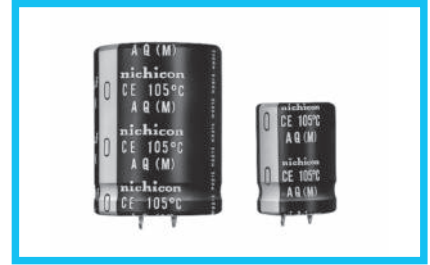
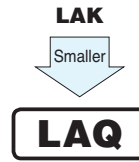

## Specifications

Item	Performance Characteristics			
Category Temperature Range	-25 to +105°C			
Rated Voltage Range	200 • 220 • 400V			
Rated Capacitance Range	33 to 1500μF			
Capacitance Tolerance	±20% at 120Hz, 20°C			
Leakage Current	$I \leq 3 \cdot \sqrt{CV}$ (μA) (After 5 minutes' application of rated voltage) [C : Rated Capacitance (μF) V : Voltage (V)]			
Tangent of loss angle (tan δ)	0.20MAX. 120Hz at 20°C			
Stability at Low Temperature	Rated voltage(V)		200 • 220	400
	Impedance ratio (MAX)	Z - 25°C/Z+20°C	8	8
Endurance	The specifications listed at right shall be met when the capacitors are restored to 20°C after D.C. bias plus rated ripple current is applied for 2000 hours at 105°C, the peak voltage shall not exceed the rated voltage.			Measurement frequency : 120Hz
	Capacitance change	Within ±20% of the initial capacitance value		
	tan δ	200% or less than the initial specified value		
Shelf Life	After storing the capacitors under no load at 105°C for 1000 hours and then performing voltage treatment based on JIS C 5101-4 clause 4.1 at 20°C, they shall meet the requirements listed at right.			Measurement frequency : 120Hz
	Capacitance change	Within ±15% of the initial capacitance value		
	tan δ	150% or less than the initial specified value		
Safety Performance	The pressure relief vent will operate in normal conditions, with no dangerous conditions such as flames, ignitions or dispersion of pieces of the capacitor and / or case.			
	Rating		Test conditions	
	Voltage (V)	Rated Capacitance (μF)	Limited DC current	Test voltage
	200	C < 330	4 A	300VDC and 375VDC
		330 ≤ C < 470	5 A	
		470 ≤ C	7 A	
	220	C < 330	4 A	320VDC and 405VDC
330 ≤ C < 470		5 A		
470 ≤ C		7 A		
400	C < 100	2 A	500VDC and 600VDC	
	100 ≤ C < 220	4 A		
	220 ≤ C	7 A		
Marking	Printed with white color letter on black sleeve			

## Drawing

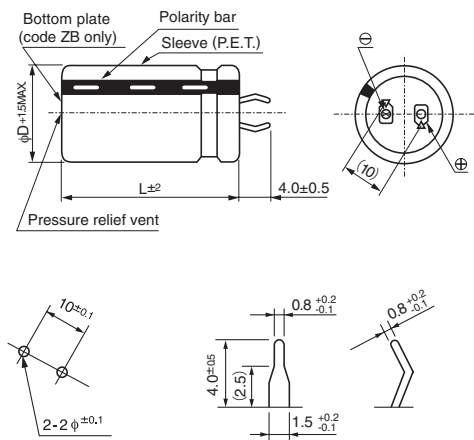

(PC board hole dimensions)

(Terminal dimensions)

## Type numbering system (Example : 200V 680μF)

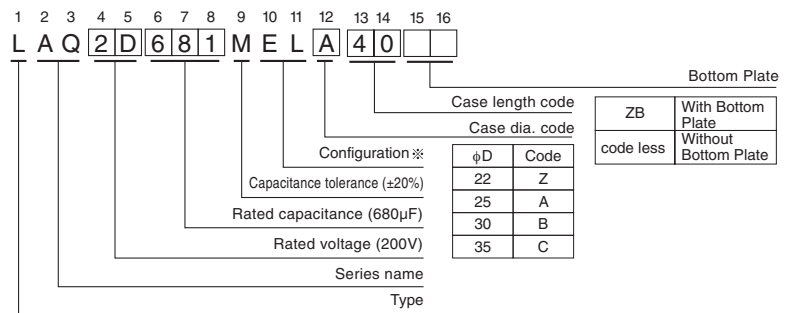

※ Please contact to us if other configurations are required.

Minimum order quantity : 50pcs.

● Dimension table in next page.



## ■ Dimensions

200V (2D)				
Cap. (μF)	Size φD × L(mm)	Ripple (mArms)	Leakage Current (mA)	Code
180	22 × 25	700	0.56	LAQ2D181MELZ25
	25 × 20	700	0.56	LAQ2D181MELA20
220	22 × 25	900	0.62	LAQ2D221MELZ25
270	22 × 25	1000	0.69	LAQ2D271MELZ25
330	22 × 30	1200	0.77	LAQ2D331MELZ30
	25 × 25	1200	0.77	LAQ2D331MELA25
390	22 × 35	1350	0.83	LAQ2D391MELZ35
	25 × 30	1350	0.83	LAQ2D391MELA30
470	22 × 40	1450	0.91	LAQ2D471MELZ40
	25 × 30	1450	0.91	LAQ2D471MELA30
	30 × 25	1450	0.91	LAQ2D471MELB25
560	22 × 45	1600	1.00	LAQ2D561MELZ45
	25 × 35	1600	1.00	LAQ2D561MELA35
	30 × 30	1600	1.00	LAQ2D561MELB30
680	22 × 50	1750	1.10	LAQ2D681MELZ50
	25 × 40	1750	1.10	LAQ2D681MELA40
	30 × 30	1750	1.10	LAQ2D681MELB30
	35 × 25	1750	1.10	LAQ2D681MELC25
820	25 × 50	2110	1.21	LAQ2D821MELA50
	30 × 35	2110	1.21	LAQ2D821MELB35
	35 × 30	2110	1.21	LAQ2D821MELC30
1000	30 × 45	2400	1.34	LAQ2D102MELB45
	35 × 35	2400	1.34	LAQ2D102MELC35
1200	30 × 50	2650	1.46	LAQ2D122MELB50
	35 × 40	2650	1.46	LAQ2D122MELC40
1500	35 × 45	3080	1.64	LAQ2D152MELC45

400V (2G)				
Cap. (μF)	Size φD × L(mm)	Ripple (mArms)	Leakage Current (mA)	Code
33	22 × 25	250	0.34	LAQ2G330MELZ25
39	22 × 25	300	0.37	LAQ2G390MELZ25
47	22 × 25	350	0.41	LAQ2G470MELZ25
56	22 × 25	450	0.44	LAQ2G560MELZ25
68	22 × 25	510	0.49	LAQ2G680MELZ25
82	22 × 30	580	0.54	LAQ2G820MELZ30
	25 × 25	580	0.54	LAQ2G820MELA25
100	22 × 30	660	0.60	LAQ2G101MELZ30
	25 × 25	660	0.60	LAQ2G101MELA25
120	22 × 35	760	0.65	LAQ2G121MELZ35
	25 × 30	760	0.65	LAQ2G121MELA30
	30 × 25	760	0.65	LAQ2G121MELB25
150	22 × 40	850	0.73	LAQ2G151MELZ40
	25 × 35	850	0.73	LAQ2G151MELA35
	30 × 25	850	0.73	LAQ2G151MELB25
180	25 × 40	950	0.80	LAQ2G181MELA40
	30 × 30	950	0.80	LAQ2G181MELB30
	35 × 25	950	0.80	LAQ2G181MELC25
220	25 × 45	1240	0.88	LAQ2G221MELA45
	30 × 35	1240	0.88	LAQ2G221MELB35
	35 × 30	1240	0.88	LAQ2G221MELC30
270	30 × 40	1300	0.98	LAQ2G271MELB40
	35 × 35	1300	0.98	LAQ2G271MELC35
330	30 × 45	1470	1.08	LAQ2G331MELB45
	35 × 35	1470	1.08	LAQ2G331MELC35
390	35 × 40	1590	1.18	LAQ2G391MELC40
470	35 × 45	1870	1.30	LAQ2G471MELC45

Rated ripple current (mArms) at 105°C 120Hz

220V (2P)				
Cap. (μF)	Size φD × L(mm)	Ripple (mArms)	Leakage Current (mA)	Code
100	22 × 20	500	0.44	LAQ2P101MELZ20
120	22 × 25	600	0.48	LAQ2P121MELZ25
150	22 × 25	650	0.54	LAQ2P151MELZ25
	25 × 20	650	0.54	LAQ2P151MELA20
180	22 × 25	700	0.59	LAQ2P181MELZ25
	25 × 25	700	0.59	LAQ2P181MELA25
220	22 × 30	900	0.66	LAQ2P221MELZ30
	25 × 25	900	0.66	LAQ2P221MELA25
	30 × 20	900	0.66	LAQ2P221MELB20
270	22 × 35	1000	0.73	LAQ2P271MELZ35
	25 × 30	1000	0.73	LAQ2P271MELA30
	30 × 25	1000	0.73	LAQ2P271MELB25
330	22 × 40	1200	0.80	LAQ2P331MELZ40
	25 × 30	1200	0.80	LAQ2P331MELA30
	30 × 25	1200	0.80	LAQ2P331MELB25
390	22 × 45	1350	0.87	LAQ2P391MELZ45
	25 × 35	1350	0.87	LAQ2P391MELA35
	30 × 30	1350	0.87	LAQ2P391MELB30
470	25 × 40	1450	0.96	LAQ2P471MELA40
	30 × 30	1450	0.96	LAQ2P471MELB30
	35 × 25	1450	0.96	LAQ2P471MELC25
560	25 × 45	1600	1.05	LAQ2P561MELA45
	30 × 35	1600	1.05	LAQ2P561MELB35
	35 × 30	1600	1.05	LAQ2P561MELC30
680	30 × 40	1750	1.16	LAQ2P681MELB40
	35 × 35	1750	1.16	LAQ2P681MELC35
820	30 × 45	2110	1.27	LAQ2P821MELB45
	35 × 40	2110	1.27	LAQ2P821MELC40
1000	35 × 45	2400	1.40	LAQ2P102MELC45

### ● Frequency coefficient of rated ripple current

Frequency (Hz)		50	60	120	1k	10k or more
Coefficient	200-220V	0.85	0.88	1.00	1.15	1.20
	400V	0.88	0.90	1.00	1.10	1.15

# ALUMINUM ELECTROLYTIC CAPACITORS

# LAS

Snap-in Terminal Type, 105°C Permissible Abnormal Voltage, Smaller-sized

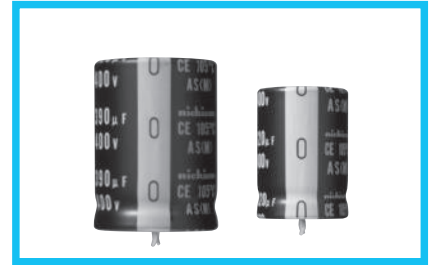

- Withstanding 2000 hours application of rated ripple current of 105°C.
- Addition of 450V rated voltage.
- Smaller case sizes and higher ripple current than LAQ.
- Improved safety features for abnormally excessive voltage.
- Ideally suited for the equipment used at voltage fluctuating area.
- Compliant to the RoHS directive (2011/65/EU,(EU)2015/863).

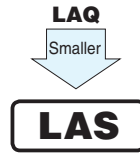

## Specifications

Item	Performance Characteristics				
Category Temperature Range	-25 to +105°C				
Rated Voltage Range	400 · 420 · 450V				
Rated Capacitance Range	56 to 390μF				
Capacitance Tolerance	±20% at 120Hz, 20°C				
Leakage Current	≤ 3·√CV (μA) (After 5 minutes' application of rated voltage at 20°C) [C : Rated Capacitance (μF) V : Voltage (V)]				
Tangent of loss angle (tan δ)	0.20MAX. 120Hz at 20°C				
Stability at Low Temperature	Rated voltage(V)	400 · 420 · 450		Measurement frequency : 120Hz	
	Impedance ratio (MAX)	Z - 25°C/Z+20°C	8		
Endurance	The specifications listed at right shall be met when the capacitors are restored to 20°C after D.C. bias plus rated ripple current is applied for 2000 hours at 105°C. the peak voltage shall not exceed the rated voltage.			Capacitance change	Within ±20% of the initial capacitance value
				tan δ	200% or less than the initial specified value
				Leakage current	Less than or equal to the initial specified value
Shelf Life	After storing the capacitors under no load at 105°C for 1000 hours and then performing voltage treatment based on JIS C 5101-4 clause 4.1 at 20°C, they shall meet the requirements listed at right.			Capacitance change	Within ±15% of the initial capacitance value
				tan δ	150% or less than the initial specified value
				Leakage current	Less than or equal to the initial specified value
Safety Performance	The pressure relief vent will operate in normal conditions, with no dangerous conditions such as flames, ignitions or dispersion of pieces of the capacitor and / or case.				
	Rating		Test conditions		
	Voltage (V)	Rated Capacitance (μF)	Limited DC current	Test voltage	
	400	C < 100	2 A	500VDC and 600VDC	
		100 ≤ C < 220	4 A		
		220 ≤ C	7 A		
	420	C < 100	2 A	520VDC and 630VDC	
100 ≤ C < 220		4 A			
220 ≤ C		7 A			
450	C < 100	2 A	550VDC and 675VDC		
	100 ≤ C < 220	4 A			
	220 ≤ C	7 A			
Marking	Printed with white color letter on black sleeve				

## Drawing

Type numbering system (Example : 400V 100μF)

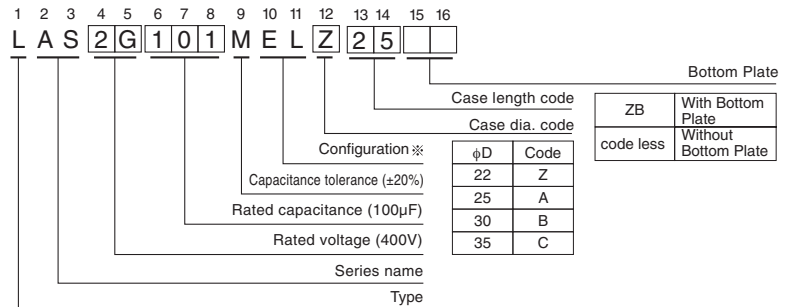
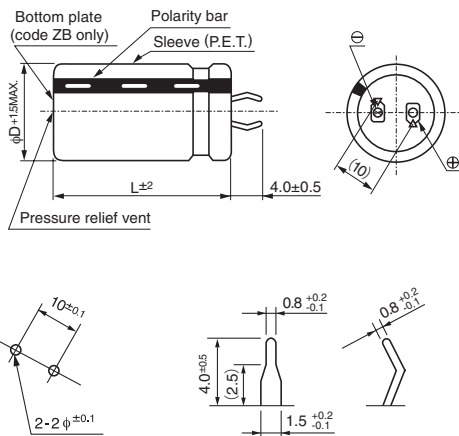

※ Please contact to us if other configurations are required.

(PC board hole dimensions)

(Terminal dimensions)

## Frequency coefficient of rated ripple current

Frequency (Hz)	50	60	120	1 k	10k or more	
Coeff.	400 · 420 · 450V	0.88	0.9	1.00	1.10	1.15

Minimum order quantity : 50pcs.

- Dimension table in next page.

## LAS

### ■Dimensions

400V(2G)				
Cap. (μF)	Size φD × L(mm)	Ripple (mArms)	Leakage Current (mA)	Code
56	22 × 20	450	0.44	LAS2G560MELZ20
68	22 × 20	510	0.49	LAS2G680MELZ20
82	22 × 25	640	0.54	LAS2G820MELZ25
100	22 × 25	680	0.60	LAS2G101MELZ25
120	22 × 30	760	0.65	LAS2G121MELZ30
	25 × 25	760	0.65	LAS2G121MELA25
150	22 × 35	880	0.73	LAS2G151MELZ35
	25 × 30	880	0.73	LAS2G151MELA30
	30 × 25	880	0.73	LAS2G151MELB25
180	22 × 40	950	0.80	LAS2G181MELZ40
	25 × 30	950	0.80	LAS2G181MELA30
	30 × 25	950	0.80	LAS2G181MELB25
220	25 × 35	1240	0.88	LAS2G221MELA35
	30 × 30	1240	0.88	LAS2G221MELB30
270	25 × 40	1300	0.98	LAS2G271MELA40
	30 × 35	1300	0.98	LAS2G271MELB35
330	30 × 35	1440	1.08	LAS2G331MELB35
390	30 × 40	1550	1.18	LAS2G391MELB40

420V(W6)				
Cap. (μF)	Size φD × L(mm)	Ripple (mArms)	Leakage Current (mA)	Code
56	22 × 25	380	0.46	LASW6560MELZ25
68	22 × 25	450	0.50	LASW6680MELZ25
82	22 × 30	640	0.55	LASW6820MELZ30
	25 × 25	640	0.55	LASW6820MELA25
100	22 × 30	690	0.61	LASW6101MELZ30
	25 × 25	690	0.61	LASW6101MELA25
120	22 × 35	750	0.67	LASW6121MELZ35
	25 × 30	750	0.67	LASW6121MELA30
	30 × 25	750	0.67	LASW6121MELB25
150	22 × 40	820	0.75	LASW6151MELZ40
	25 × 35	820	0.75	LASW6151MELA35
	30 × 25	820	0.75	LASW6151MELB25
180	25 × 40	900	0.82	LASW6181MELA40
	30 × 30	900	0.82	LASW6181MELB30
	35 × 25	900	0.82	LASW6181MELC25
220	25 × 45	1000	0.91	LASW6221MELA45
	30 × 35	1000	0.91	LASW6221MELB35
	35 × 30	1000	0.91	LASW6221MELC30
270	30 × 40	1100	1.01	LASW6271MELB40
	35 × 30	1100	1.01	LASW6271MELC30
330	30 × 45	1200	1.11	LASW6331MELB45
	35 × 35	1200	1.11	LASW6331MELC35
390	35 × 45	1300	1.21	LASW6391MELC45

450V (2W)				
Cap. (μF)	Size φD × L(mm)	Ripple (mArms)	Leakage Current (mA)	Code
68	22 × 25	600	0.52	LAS2W680MELZ25
82	22 × 30	650	0.57	LAS2W820MELZ30
	25 × 25	610	0.57	LAS2W820MELA25
100	22 × 30	710	0.63	LAS2W101MELZ30
	25 × 25	710	0.63	LAS2W101MELA25
120	22 × 35	770	0.69	LAS2W121MELZ35
	25 × 30	760	0.69	LAS2W121MELA30
	30 × 25	770	0.69	LAS2W121MELB25
150	25 × 35	880	0.77	LAS2W151MELA35
	30 × 25	880	0.77	LAS2W151MELB25
180	30 × 30	970	0.85	LAS2W181MELB30
220	30 × 35	1300	0.94	LAS2W221MELB35
270	35 × 30	1300	1.04	LAS2W271MELC30
330	35 × 35	1400	1.15	LAS2W331MELC35

Rated ripple current (mArms) at 105°C 120Hz

## LAR

Snap-in Terminal Type, 105°C Permissible Overvoltage

- Withstanding 2000 hours application of rated ripple current at 105°C.
- Reduction of short incidence when overvoltage (rated voltage x 1.5) is applied to a capacitor.
- Compliant to the RoHS directive (2011/65/EU, (EU)2015/863).

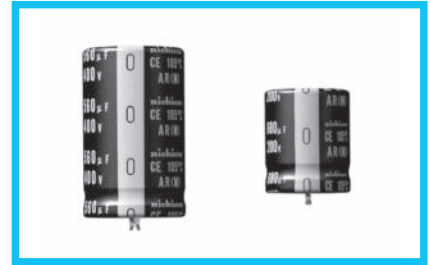

### Specifications

Item	Performance Characteristics															
Category Temperature Range	-40 to +105°C (200·250V), -25 to +105°C (400·450V)															
Rated Voltage Range	200 to 450V															
Rated Capacitance Range	82 to 2200μF															
Capacitance Tolerance	±20% at 120Hz, 20°C															
Leakage Current	$I \leq 3\sqrt{CV}$ (μA) (After 5 minutes' application of rated voltage [C: Rated Capacitance(μF), V: Voltage(V)])															
Tangent of loss angle (tan δ)	<table border="1"> <tr> <th>Rated voltage (V)</th> <th>200 to 400</th> <th>450</th> </tr> <tr> <td>tan δ (MAX.)</td> <td>0.15</td> <td>0.20</td> </tr> </table> <p>Measurement frequency : 120Hz at 20°C</p>		Rated voltage (V)	200 to 400	450	tan δ (MAX.)	0.15	0.20								
Rated voltage (V)	200 to 400	450														
tan δ (MAX.)	0.15	0.20														
Stability at Low Temperature	<p>Measurement frequency : 120Hz</p> <table border="1"> <tr> <th rowspan="2">Rated voltage(V)</th> <th colspan="2">200 · 250</th> <th colspan="2">400 · 450</th> </tr> <tr> <th>Z - 25°C / Z+20°C</th> <th>3</th> <th>8</th> <th>—</th> </tr> <tr> <th>ZT/Z20(MAX.)</th> <th>Z - 40°C / Z+20°C</th> <td>12</td> <td>—</td> <td>—</td> </tr> </table>		Rated voltage(V)	200 · 250		400 · 450		Z - 25°C / Z+20°C	3	8	—	ZT/Z20(MAX.)	Z - 40°C / Z+20°C	12	—	—
Rated voltage(V)	200 · 250			400 · 450												
	Z - 25°C / Z+20°C	3	8	—												
ZT/Z20(MAX.)	Z - 40°C / Z+20°C	12	—	—												
Endurance	The specifications listed at right shall be met when the capacitors are restored to 20°C after D.C. bias plus rated ripple current is applied for 2000 hours at 105°C, the peak voltage shall not exceed the rated voltage.	<table border="1"> <tr> <td>Capacitance change</td> <td>Within ±20% of the initial capacitance value</td> </tr> <tr> <td>tan δ</td> <td>200% or less than the initial specified value</td> </tr> <tr> <td>Leakage current</td> <td>Less than or equal to the initial specified value</td> </tr> </table>	Capacitance change	Within ±20% of the initial capacitance value	tan δ	200% or less than the initial specified value	Leakage current	Less than or equal to the initial specified value								
Capacitance change	Within ±20% of the initial capacitance value															
tan δ	200% or less than the initial specified value															
Leakage current	Less than or equal to the initial specified value															
Shelf Life	After storing the capacitors under no load at 105°C for 1000 hours and then performing voltage treatment based on JIS C 5101-4 clause 4.1 at 20°C, they shall meet the requirements listed at right.	<table border="1"> <tr> <td>Capacitance change</td> <td>Within ±15% of the initial capacitance value</td> </tr> <tr> <td>tan δ</td> <td>150% or less than the initial specified value</td> </tr> <tr> <td>Leakage current</td> <td>Less than or equal to the initial specified value</td> </tr> </table>	Capacitance change	Within ±15% of the initial capacitance value	tan δ	150% or less than the initial specified value	Leakage current	Less than or equal to the initial specified value								
Capacitance change	Within ±15% of the initial capacitance value															
tan δ	150% or less than the initial specified value															
Leakage current	Less than or equal to the initial specified value															
Safety Performance	When overvoltage (rated voltage x 1.5, limited current = 1A) is applied to a capacitor, the pressure relief vent will operate normally more than 60% of the time without short and flame.															
Marking	Printed with white color letter on black sleeve.															

### Drawing

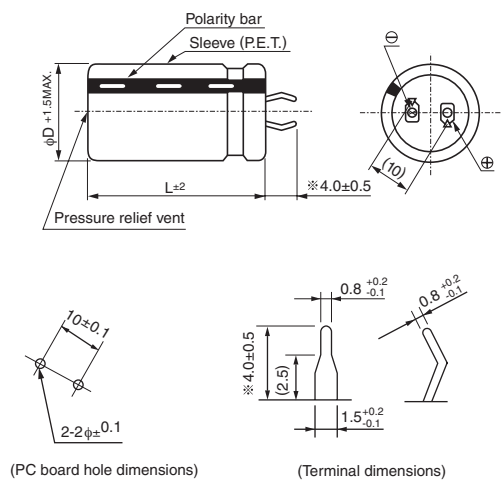

※ The other terminal is also available upon request.  
Please refer to page "Snap-in Terminal type Terminal-Shape" for schematic of dimensions.

### Type numbering system (Example : 400V 120μF)

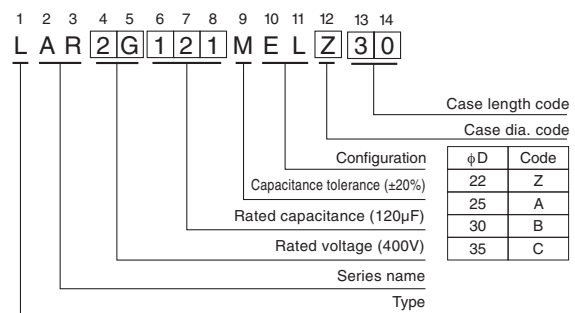

### Frequency coefficient of rated ripple current

Frequency(Hz)	50	60	120	300	1k	10k	50k or more
coeff. 200.250V	0.81	0.85	1.00	1.17	1.32	1.45	1.50
400.450V	0.77	0.82	1.00	1.16	1.30	1.41	1.43

Minimum order quantity : 50pcs.

●Dimension table in next page.

## LAR

### ■ Dimensions

200V (2D)				
Cap. (μF)	Size φD × L (mm)	Rated ripple (mArms)	Leakage Current (mA)	Code
390	22 × 25	1310	0.83	LAR2D391MELZ25
470	22 × 30	1480	0.91	LAR2D471MELZ30
	25 × 25	1480	0.91	LAR2D471MELA25
560	22 × 35	1600	1.00	LAR2D561MELZ35
680	22 × 40	1750	1.10	LAR2D681MELZ40
	25 × 30	1750	1.10	LAR2D681MELA30
	30 × 25	1750	1.10	LAR2D681MELB25
820	22 × 45	2040	1.21	LAR2D821MELZ45
	25 × 35	2040	1.21	LAR2D821MELA35
1000	22 × 50	2300	1.34	LAR2D102MELZ50
	25 × 45	2300	1.34	LAR2D102MELA45
	30 × 30	2300	1.34	LAR2D102MELB30
	35 × 25	2300	1.34	LAR2D102MELC25
1200	25 × 50	2650	1.46	LAR2D122MELA50
	30 × 35	2650	1.46	LAR2D122MELB35
	35 × 30	2650	1.46	LAR2D122MELC30
1500	30 × 40	2800	1.64	LAR2D152MELB40
	35 × 35	2800	1.64	LAR2D152MELC35
1800	30 × 50	3080	1.80	LAR2D182MELB50
	35 × 40	3080	1.80	LAR2D182MELC40
2200	35 × 45	3480	1.98	LAR2D222MELC45

250V (2E)				
Cap. (μF)	Size φD × L (mm)	Rated ripple (mArms)	Leakage Current (mA)	Code
270	22 × 25	1100	0.77	LAR2E271MELZ25
330	22 × 30	1200	0.86	LAR2E331MELZ30
	25 × 25	1200	0.86	LAR2E331MELA25
390	22 × 35	1300	0.93	LAR2E391MELZ35
	25 × 30	1300	0.93	LAR2E391MELA30
470	22 × 40	1400	1.02	LAR2E471MELZ40
	25 × 35	1400	1.02	LAR2E471MELA35
	30 × 25	1400	1.02	LAR2E471MELB25
560	22 × 45	1500	1.12	LAR2E561MELZ45
	25 × 35	1500	1.12	LAR2E561MELA35
	30 × 30	1500	1.12	LAR2E561MELB30
680	22 × 50	1700	1.23	LAR2E681MELZ50
	25 × 40	1700	1.23	LAR2E681MELA40
	30 × 30	1700	1.23	LAR2E681MELB30
820	25 × 45	2000	1.35	LAR2E821MELA45
	30 × 35	2000	1.35	LAR2E821MELB35
	35 × 30	2000	1.35	LAR2E821MELC30
1000	30 × 40	2200	1.50	LAR2E102MELB40
	35 × 35	2200	1.50	LAR2E102MELC35
1200	30 × 45	2300	1.64	LAR2E122MELB45
	35 × 40	2300	1.64	LAR2E122MELC40
1500	35 × 45	2500	1.83	LAR2E152MELC45
1800	35 × 50	2700	2.01	LAR2E182MELC50

400V (2G)				
Cap. (μF)	Size φD × L (mm)	Rated ripple (mArms)	Leakage Current (mA)	Code
100	22 × 25	680	0.60	LAR2G101MELZ25
120	22 × 30	730	0.65	LAR2G121MELZ30
180	22 × 35	950	0.80	LAR2G181MELZ35
	25 × 30	950	0.80	LAR2G181MELA30
220	22 × 45	1100	0.88	LAR2G221MELZ45
	25 × 35	1100	0.88	LAR2G221MELA35
270	22 × 50	1220	0.98	LAR2G271MELZ50
	25 × 40	1220	0.98	LAR2G271MELA40
	30 × 30	1220	0.98	LAR2G271MELB30
330	25 × 45	1440	1.08	LAR2G331MELA45
	30 × 35	1440	1.08	LAR2G331MELB35
390	25 × 50	1550	1.18	LAR2G391MELA50
	30 × 40	1550	1.18	LAR2G391MELB40
470	30 × 45	1680	1.30	LAR2G471MELB45
	35 × 35	1680	1.30	LAR2G471MELC35
560	30 × 50	1900	1.41	LAR2G561MELB50
	35 × 40	1900	1.41	LAR2G561MELC40
680	35 × 45	2120	1.56	LAR2G681MELC45

450V (2W)				
Cap. (μF)	Size φD × L (mm)	Rated ripple (mArms)	Leakage Current (mA)	Code
82	22 × 25	340	0.57	LAR2W820MELZ25
100	22 × 30	690	0.63	LAR2W101MELZ30
	25 × 25	690	0.63	LAR2W101MELA25
120	22 × 35	720	0.69	LAR2W121MELZ35
	25 × 30	720	0.69	LAR2W121MELA30
150	22 × 40	790	0.77	LAR2W151MELZ40
	25 × 30	790	0.77	LAR2W151MELA30
	30 × 25	790	0.77	LAR2W151MELB25
180	22 × 45	870	0.85	LAR2W181MELZ45
	25 × 35	870	0.85	LAR2W181MELA35
	30 × 30	870	0.85	LAR2W181MELB30
220	25 × 40	1050	0.94	LAR2W221MELA40
	30 × 30	1050	0.94	LAR2W221MELB30
	35 × 25	1050	0.94	LAR2W221MELC25
270	25 × 50	1230	1.04	LAR2W271MELA50
	30 × 35	1230	1.04	LAR2W271MELB35
	35 × 30	1230	1.04	LAR2W271MELC30
330	30 × 40	1380	1.15	LAR2W331MELB40
	35 × 35	1380	1.15	LAR2W331MELC35
390	30 × 50	1610	1.25	LAR2W391MELB50
	35 × 40	1610	1.25	LAR2W391MELC40
470	35 × 45	1780	1.37	LAR2W471MELC45
560	35 × 50	1990	1.50	LAR2W561MELC50

Rated ripple current (mArms) at 105°C 120Hz

# ALUMINUM ELECTROLYTIC CAPACITORS

# LQS

Snap-in Terminal type, 105°C High speed charge-discharge.



- Suited for high frequency regenerative voltage for AC servomotor, general inverter.
- Suited for equipment used at voltage fluctuating area.
- Suited for rectifier circuit of voltage doubler
- Compliant to the RoHS directive (2011/65/EU, (EU)2015/863).

**LQS**

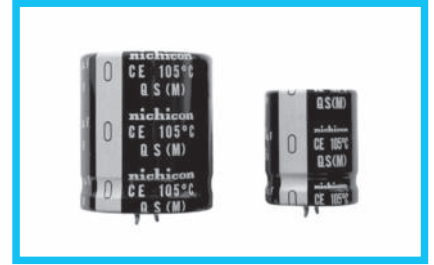
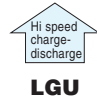

## Specifications

Item	Performance Characteristics					
Category Temperature Range	- 25 to +105°C					
Rated Voltage Range	350 to 450V					
Rated Capacitance Range	82 to 820μF					
Capacitance Tolerance	±20% at 120Hz, 20°C					
Leakage Current	$I \leq 3\sqrt{CV}$ (μA) (After 5 minutes' application of rated voltage [C: Rated Capacitance(μF), V: Voltage (V)])					
Tangent of loss angle (tan δ)	Measurement frequency : 120Hz at 20°C					
	Rated voltage (V)	350	400	420	450	
	tan δ (MAX.)	0.15	0.15	0.15	0.20	
Stability at Low Temperature	Rated voltage (V)		350 to 450		Measurement frequency : 120Hz	
	Impedance ratio ZT/Z20(MAX.)		Z - 25°C / Z+20°C			
			8			
Endurance of charge-discharge behavior	After an application of charge-discharge voltage for 50million times (charge-discharge voltage difference(ΔV) = rated voltage × 0.35, cycle 6Hz) capacitors shall meet the characteristics requirement listed at right.				Capacitance change	Within ±20% of the initial capacitance value
					tan δ	300% or less than the initial specified value
					Leakage current	Less than or equal to the initial specified value
					Appearance	There shall be found to remarkable abnormality on the capacitor
Endurance	The specifications listed at right shall be met when the capacitors are restored to 20°C after D.C. bias plus rated ripple current is applied for 3000 hours at 105°C, the peak voltage shall not exceed the rated voltage.				Capacitance change	Within ±20% of the initial capacitance value
					tan δ	200% or less than the initial specified value
					Leakage current	Less than or equal to the initial specified value
Shelf Life	After storing the capacitors under no load at 105°C for 1000 hours and then performing voltage treatment based on JIS C 5101-4 clause 4.1 at 20°C, they shall meet the specified value for endurance characteristics listed above.					
Marking	Printed with white color letter on black sleeve.					

## Drawing

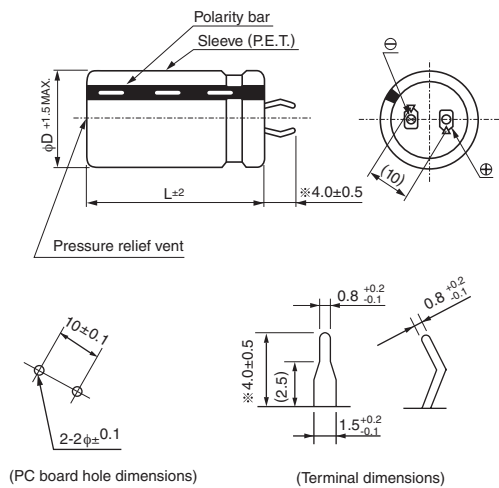

## Type numbering system (Example : 400V 180μF)

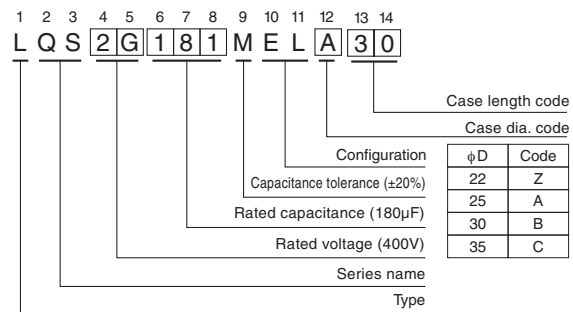

※ Please contact to us if other configurations are required.

※ Other terminations available upon request.  
Please refer to the Guidelines for Aluminum Electrolytic Capacitors.

Minimum order quantity : 50pcs.

● Dimension table in next page.



## ■ Dimensions

350V (2V)				
Cap. (μF)	Size φD × L (mm)	Rated ripple (mArms)	Leakage Current (mA)	Code
120	22 × 25	750	0.61	LQS2V121MELZ25
150	22 × 30	820	0.68	LQS2V151MELZ30
180	22 × 30	900	0.75	LQS2V181MELZ30
	25 × 25	900	0.75	LQS2V181MELA25
220	22 × 35	1000	0.83	LQS2V221MELZ35
	25 × 30	1000	0.83	LQS2V221MELA30
270	22 × 40	1100	0.92	LQS2V271MELZ40
	25 × 35	1100	0.92	LQS2V271MELA35
	30 × 25	1100	0.92	LQS2V271MELB25
330	22 × 45	1200	1.01	LQS2V331MELZ45
	25 × 40	1200	1.01	LQS2V331MELA40
	30 × 30	1200	1.01	LQS2V331MELB30
390	25 × 45	1300	1.10	LQS2V391MELA45
	30 × 35	1300	1.10	LQS2V391MELB35
470	25 × 50	1400	1.21	LQS2V471MELA50
	30 × 40	1400	1.21	LQS2V471MELB40
560	35 × 30	1400	1.21	LQS2V471MELC30
	30 × 45	1500	1.32	LQS2V561MELB45
680	35 × 35	1500	1.32	LQS2V561MELC35
	30 × 50	1700	1.46	LQS2V681MELB50
820	35 × 40	1700	1.46	LQS2V681MELC40
	35 × 45	1900	1.60	LQS2V821MELC45

400V (2G)				
Cap. (μF)	Size φD × L (mm)	Rated ripple (mArms)	Leakage Current (mA)	Code
100	22 × 25	680	0.60	LQS2G101MELZ25
120	22 × 30	730	0.65	LQS2G121MELZ30
150	22 × 35	850	0.73	LQS2G151MELZ35
180	22 × 35	950	0.80	LQS2G181MELZ35
	25 × 30	950	0.80	LQS2G181MELA30
	30 × 25	950	0.80	LQS2G181MELB25
220	22 × 45	1100	0.88	LQS2G221MELZ45
	25 × 35	1100	0.88	LQS2G221MELA35
	30 × 25	1100	0.88	LQS2G221MELB25
	22 × 50	1220	0.98	LQS2G271MELZ50
270	25 × 40	1220	0.98	LQS2G271MELA40
	30 × 30	1220	0.98	LQS2G271MELB30
	35 × 25	1220	0.98	LQS2G271MELC25
330	25 × 45	1440	1.08	LQS2G331MELA45
	30 × 35	1440	1.08	LQS2G331MELB35
390	25 × 50	1550	1.18	LQS2G391MELA50
	30 × 40	1550	1.18	LQS2G391MELB40
	35 × 30	1550	1.18	LQS2G391MELC30
470	30 × 45	1680	1.30	LQS2G471MELB45
	35 × 35	1680	1.30	LQS2G471MELC35
560	30 × 50	1900	1.41	LQS2G561MELB50
	35 × 40	1900	1.41	LQS2G561MELC40
680	35 × 45	2120	1.56	LQS2G681MELC45

420V (W6)				
Cap. (μF)	Size φD × L (mm)	Rated ripple (mArms)	Leakage Current (mA)	Code
100	22 × 25	660	0.61	LQSW6101MELZ25
120	22 × 30	810	0.67	LQSW6121MELZ30
	25 × 25	810	0.67	LQSW6121MELA25
150	22 × 35	840	0.75	LQSW6151MELZ35
	25 × 30	840	0.75	LQSW6151MELA30
180	22 × 40	910	0.82	LQSW6181MELZ40
	25 × 30	910	0.82	LQSW6181MELA30
	30 × 25	910	0.82	LQSW6181MELB25
220	22 × 45	1050	0.91	LQSW6221MELZ45
	25 × 35	1050	0.91	LQSW6221MELA35
	30 × 30	1050	0.91	LQSW6221MELB30
270	25 × 40	1250	1.01	LQSW6271MELA40
	30 × 30	1250	1.01	LQSW6271MELB30
	35 × 25	1250	1.01	LQSW6271MELC25
330	25 × 50	1420	1.11	LQSW6331MELA50
	30 × 35	1420	1.11	LQSW6331MELB35
	35 × 30	1420	1.11	LQSW6331MELC30
390	30 × 40	1610	1.21	LQSW6391MELB40
	35 × 35	1610	1.21	LQSW6391MELC35
470	30 × 45	1860	1.33	LQSW6471MELB45
	35 × 40	1860	1.33	LQSW6471MELC40
560	35 × 45	2100	1.45	LQSW6561MELC45
680	35 × 50	2200	1.60	LQSW6681MELC50

450V (2W)				
Cap. (μF)	Size φD × L (mm)	Rated ripple (mArms)	Leakage Current (mA)	Code
82	22 × 25	640	0.57	LQS2W820MELZ25
100	22 × 30	690	0.63	LQS2W101MELZ30
	25 × 25	690	0.63	LQS2W101MELA25
120	22 × 35	720	0.69	LQS2W121MELZ35
	25 × 30	720	0.69	LQS2W121MELA30
150	22 × 40	790	0.77	LQS2W151MELZ40
	25 × 30	790	0.77	LQS2W151MELA30
	30 × 25	790	0.77	LQS2W151MELB25
	22 × 45	870	0.85	LQS2W181MELZ45
180	25 × 35	870	0.85	LQS2W181MELA35
	30 × 30	870	0.85	LQS2W181MELB30
	25 × 40	1050	0.94	LQS2W221MELA40
220	30 × 30	1050	0.94	LQS2W221MELB30
	35 × 25	1050	0.94	LQS2W221MELC25
	25 × 50	1230	1.04	LQS2W271MELA50
270	30 × 35	1230	1.04	LQS2W271MELB35
	35 × 30	1230	1.04	LQS2W271MELC30
	30 × 40	1380	1.15	LQS2W331MELB40
330	35 × 35	1380	1.15	LQS2W331MELC35
	30 × 50	1610	1.25	LQS2W391MELB50
390	35 × 40	1610	1.25	LQS2W391MELC40
	35 × 45	1780	1.37	LQS2W471MELC45
560	35 × 50	1990	1.50	LQS2W561MELC50

Rated ripple current (mArms) at 105°C 120Hz

## ● Frequency coefficient of rated ripple current

Frequency (Hz)	50	60	120	300	1k	10k	50k or more
Coefficient	0.77	0.82	1.00	1.16	1.30	1.41	1.43



# ALUMINUM ELECTROLYTIC CAPACITORS

# LNR

Screw Terminal Type, 85°C Standard



- Load life of 5000 hours application of rated ripple current at 85°C.
- Extended range up to  $\phi 100 \times 250L$  size.
- Compliant to the RoHS directive (2011/65/EU,(EU)2015/863).

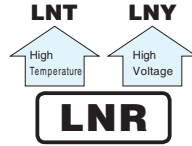

## Specifications

Item	Performance Characteristics	
Category Temperature Range	- 40 to +85°C (10 to 100V) , - 25 to +85°C (160 to 250V)	
Rated Voltage Range	10 to 250V	
Rated Capacitance Range	1000 to 680000 $\mu$ F	
Capacitance Tolerance	$\pm 20\%$ at 120Hz, 20°C	
Leakage Current	After 5 minutes' application of rated voltage, leakage current is not more than $3\sqrt{CV}$ ( $\mu$ A) or 5 mA, whichever is smaller (at 20°C) . [C:Rated Capacitance ( $\mu$ F) , V:Voltage(V)]	
Tangent of loss angle (tan $\delta$ ) (MAX)	See refer to next page (Measurement frequency : 120Hz at 20°C)	
Stability at Low Temperature	Measurement frequency : 120Hz	
	Rated voltage(V)	10 to 100
Impedance ratio ZT/Z20(MAX.)	Z - 40°C / Z+20°C	160 to 250
		Z - 25°C / Z+20°C
Endurance	The specifications listed at right shall be met when the capacitors are restored to 20°C after D.C. bias plus rated ripple current is applied for 5000 hours at 85°C, the peak voltage shall not exceed the rated voltage.	
	Capacitance change	tan $\delta$
Shelf Life	After storing the capacitors under no load at 85°C for 1000 hours and then performing voltage treatment based on JIS C 5101-4 clause 4.1 at 20°C, they shall meet the requirements listed at right.	
	Capacitance change	tan $\delta$
Marking	Printed with black color letter on light blue sleeve.	

## Drawing

$\phi 35$  Screw terminal type

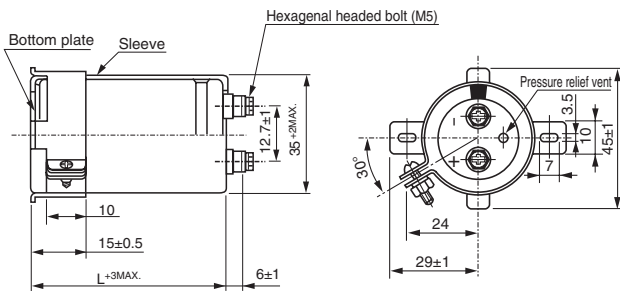

## Type numbering system (Example : 250V 2200 $\mu$ F)

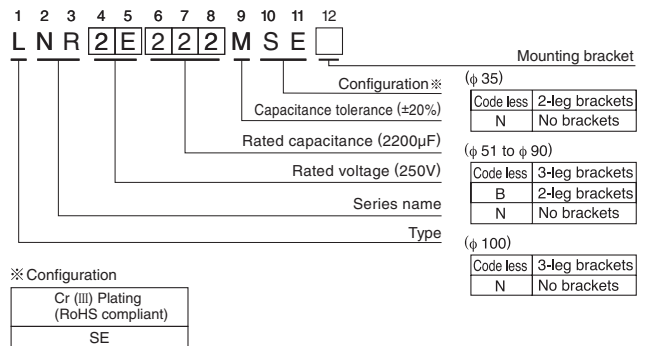

Please refer to the Guidelines for Aluminum Electrolytic Capacitors for dimensions information.  
 ※Please contact to us if PVCless products are required.

● Dimension table in next page.

## LNR

Screw terminal types for  $\phi 51$  and larger

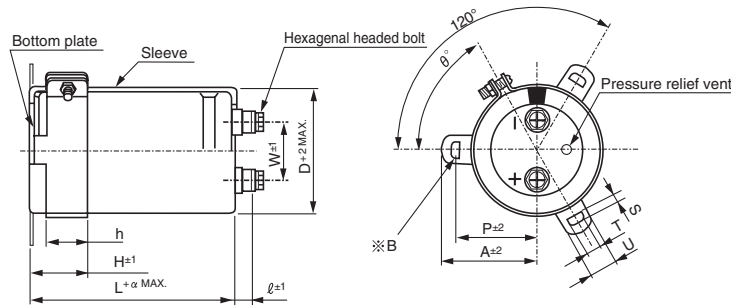

※B  
3-leg brackets for  $\phi 90$  capacitors have different hole shapes from the ordinary ones as illustrated below.

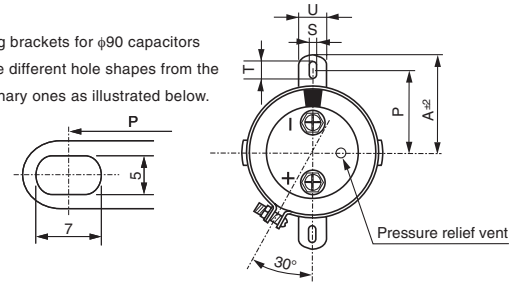

Note:  
Capacitors with body dia.  $\phi 51$  or larger are furnished with 3-leg brackets shown above as standard.

If these capacitors are preferred to have 2-leg brackets as shown right, add "B" in the 12th digit of type numbering system.

● Dimension of terminal pitch (W) and length ( $\ell$ ) and Nominal dia. of bolt (mm)

$\phi D$	W	$\ell$	$\alpha$	Nominal dia. of bolt
51	22.0	6	3	M5
63.5	28.6	6	3	M5
76.2	31.8	6	3	M5
90	31.8	6	3	M5
100	41.5	10	4	M8

● Dimensions of mounting bracket (mm)

Leg Shape Symbol	$\phi D$	3-Legs					2-Legs			
		51	63.5	76.2	90	100	51	63.5	76.2	90
P		32.5	38.1	44.5	50.8	56.3	33.2	40.5	46.5	53
A		38.5	43	49.2	58.5	62	40	46.5	53	59
T		7.5	8.0	7.0	8.0	8.0	6.0	7.0	6.0	6.0
S		5.0	5.0	5.0	5.0	5.0	4.5	4.5	4.5	4.5
U		12	14	14	18	16	14	14	14	14
$\theta^\circ$		60	60	60	60	60	30	30	30	30
H		20	25	30	35	36	25	35	35	35
h		15	20	24	25	30	15	20	20	20

■ Dimensions

10V (1A)					
Cap. ( $\mu F$ )	Size $\phi D \times L$ (mm)	Rated ripple (Arms)	$\tan \delta$	Leakage Current (mA)	Code
47000	35 × 80	6.0	0.60	2.05	LNR1A473MSE
68000	35 × 80	7.2	0.60	2.47	LNR1A683MSE
100000	35 × 100	8.8	0.60	3.00	LNR1A104MSE
150000	51 × 80	10.7	0.90	3.67	LNR1A154MSE
220000	51 × 100	13.0	0.90	4.44	LNR1A224MSE
330000	63.5 × 100	15.9	0.90	5.00	LNR1A334MSE
470000	63.5 × 120	19.0	1.20	5.00	LNR1A474MSE
680000	76.2 × 120	22.8	1.60	5.00	LNR1A684MSE

16V (1C)					
Cap. ( $\mu F$ )	Size $\phi D \times L$ (mm)	Rated ripple (Arms)	$\tan \delta$	Leakage Current (mA)	Code
47000	35 × 80	6.4	0.40	2.60	LNR1C473MSE
68000	35 × 100	7.9	0.40	3.12	LNR1C683MSE
100000	35 × 120	10.6	0.55	3.79	LNR1C104MSE
150000	51 × 100	11.5	0.60	4.64	LNR1C154MSE
220000	51 × 120	15.6	0.80	5.00	LNR1C224MSE
330000	63.5 × 120	25.1	0.75	5.00	LNR1C334MSE
470000	76.2 × 120	30.5	1.10	5.00	LNR1C474MSE
680000	90 × 170	33.0	1.50	5.00	LNR1C684MSE

Rated ripple current (Arms) at 85°C 120Hz

## LNR

### ■ Dimensions

25V (1E)					
Cap. (μF)	Size φD × L(mm)	Rated ripple (Arms)	tan δ	Leakage Current (mA)	Code
33000	35 × 80	6.2	0.35	2.72	LNR1E333MSE
47000	35 × 100	8.2	0.35	3.25	LNR1E473MSE
68000	35 × 120	9.4	0.40	3.91	LNR1E683MSE
100000	51 × 100	12.0	0.45	4.74	LNR1E104MSE
150000	51 × 120	15.3	0.50	5.00	LNR1E154MSE
220000	63.5 × 120	18.9	0.65	5.00	LNR1E224MSE
330000	76.2 × 120	24.8	0.75	5.00	LNR1E334MSE
470000	90 × 170	30.8	1.00	5.00	LNR1E474MSE
680000	90 × 220	33.3	1.00	5.00	LNR1E684MSE

35V (1V)					
Cap. (μF)	Size φD × L(mm)	Rated ripple (Arms)	tan δ	Leakage Current (mA)	Code
33000	35 × 80	6.2	0.30	3.22	LNR1V333MSE
47000	35 × 120	8.2	0.30	3.84	LNR1V473MSE
68000	51 × 80	9.3	0.35	4.62	LNR1V683MSE
100000	51 × 120	13.6	0.40	5.00	LNR1V104MSE
150000	63.5 × 100	14.5	0.50	5.00	LNR1V154MSE
220000	76.2 × 100	16.8	0.65	5.00	LNR1V224MSE
330000	76.2 × 140	24.8	0.75	5.00	LNR1V334MSE
470000	90 × 170	32.6	0.90	5.00	LNR1V474MSE
680000	90 × 220	35.2	0.90	5.00	LNR1V684MSE

50V (1H)					
Cap. (μF)	Size φD × L(mm)	Rated ripple (Arms)	tan δ	Leakage Current (mA)	Code
15000	35 × 80	5.4	0.25	2.59	LNR1H153MSE
22000	35 × 100	6.1	0.25	3.14	LNR1H223MSE
33000	51 × 70	7.0	0.25	3.85	LNR1H333MSE
47000	51 × 90	8.6	0.25	4.59	LNR1H473MSE
68000	51 × 100	11.0	0.25	5.00	LNR1H683MSE
100000	63.5 × 100	14.2	0.35	5.00	LNR1H104MSE
150000	76.2 × 120	18.6	0.55	5.00	LNR1H154MSE
220000	90 × 140	20.3	0.75	5.00	LNR1H224MSE
330000	90 × 170	25.3	0.75	5.00	LNR1H334MSE
470000	90 × 220	33.2	0.75	5.00	LNR1H474MSE
680000	100 × 250	36.0	0.75	5.00	LNR1H684MSE

63V (1J)					
Cap. (μF)	Size φD × L(mm)	Rated ripple (Arms)	tan δ	Leakage Current (mA)	Code
10000	35 × 80	4.1	0.25	2.38	LNR1J103MSE
15000	35 × 100	5.5	0.25	2.91	LNR1J153MSE
22000	35 × 120	7.1	0.25	3.53	LNR1J223MSE
33000	51 × 80	8.8	0.25	4.32	LNR1J333MSE
47000	51 × 120	11.7	0.25	5.00	LNR1J473MSE
68000	63.5 × 100	15.0	0.30	5.00	LNR1J683MSE
100000	63.5 × 140	20.8	0.30	5.00	LNR1J104MSE
150000	76.2 × 140	26.0	0.50	5.00	LNR1J154MSE
220000	90 × 170	28.3	0.60	5.00	LNR1J224MSE
330000	90 × 220	31.2	0.60	5.00	LNR1J334MSE
470000	100 × 250	33.6	0.60	5.00	LNR1J474MSE

80V (1K)					
Cap. (μF)	Size φD × L(mm)	Rated ripple (Arms)	tan δ	Leakage Current (mA)	Code
10000	35 × 80	4.2	0.20	2.68	LNR1K103MSE
15000	35 × 120	6.0	0.20	3.28	LNR1K153MSE
22000	51 × 80	6.5	0.20	3.97	LNR1K223MSE
33000	51 × 120	9.2	0.20	4.87	LNR1K333MSE
47000	63.5 × 100	12.7	0.25	5.00	LNR1K473MSE
68000	63.5 × 140	15.5	0.30	5.00	LNR1K683MSE
100000	76.2 × 140	21.3	0.35	5.00	LNR1K104MSE
150000	90 × 170	26.5	0.40	5.00	LNR1K154MSE
220000	90 × 220	28.9	0.40	5.00	LNR1K224MSE
330000	100 × 250	31.8	0.40	5.00	LNR1K334MSE

100V (2A)					
Cap. (μF)	Size φD × L(mm)	Rated ripple (Arms)	tan δ	Leakage Current (mA)	Code
4700	35 × 80	3.8	0.12	2.05	LNR2A472MSE
6800	35 × 100	4.5	0.12	2.47	LNR2A682MSE
10000	35 × 120	5.3	0.15	3.00	LNR2A103MSE
15000	51 × 80	6.0	0.15	3.67	LNR2A153MSE
22000	51 × 100	6.8	0.15	4.45	LNR2A223MSE
33000	51 × 140	10.0	0.15	5.00	LNR2A333MSE
47000	63.5 × 140	14.4	0.20	5.00	LNR2A473MSE
68000	76.2 × 140	18.2	0.30	5.00	LNR2A683MSE
100000	90 × 170	22.1	0.30	5.00	LNR2A104MSE
150000	90 × 220	27.0	0.30	5.00	LNR2A154MSE
220000	100 × 250	32.7	0.30	5.00	LNR2A224MSE

Rated ripple current (Arms) at 85°C, 120Hz

## LNR

### ■ Dimensions

160V (2C)					
Cap. (μF)	Size φD × L(mm)	Rated ripple (Arms)	tan δ	Leakage Current (mA)	Code
2200	35 × 80	3.2	0.15	1.77	LNR2C222MSE
3300	35 × 120	4.7	0.15	2.17	LNR2C332MSE
4700	51 × 80	5.0	0.15	2.60	LNR2C472MSE
6800	51 × 100	6.4	0.15	3.12	LNR2C682MSE
10000	63.5 × 100	9.1	0.20	3.79	LNR2C103MSE
15000	76.2 × 100	12.0	0.20	4.64	LNR2C153MSE
22000	76.2 × 140	16.9	0.20	5.00	LNR2C223MSE
33000	90 × 140	19.2	0.25	5.00	LNR2C333MSE
47000	90 × 170	20.6	0.25	5.00	LNR2C473MSE
68000	90 × 220	22.3	0.25	5.00	LNR2C683MSE

200V (2D)					
Cap. (μF)	Size φD × L(mm)	Rated ripple (Arms)	tan δ	Leakage Current (mA)	Code
1500	35 × 80	2.9	0.15	1.64	LNR2D152MSE
2200	35 × 100	3.5	0.15	1.99	LNR2D222MSE
3300	51 × 80	4.8	0.15	2.43	LNR2D332MSE
4700	51 × 100	6.3	0.15	2.90	LNR2D472MSE
6800	51 × 140	7.3	0.15	3.49	LNR2D682MSE
10000	63.5 × 120	9.8	0.20	4.24	LNR2D103MSE
15000	76.2 × 120	13.0	0.20	5.00	LNR2D153MSE
22000	90 × 140	15.9	0.25	5.00	LNR2D223MSE
33000	90 × 170	19.5	0.25	5.00	LNR2D333MSE
47000	90 × 220	20.9	0.25	5.00	LNR2D473MSE
68000	100 × 250	22.6	0.25	5.00	LNR2D683MSE

250V (2E)					
Cap. (μF)	Size φD × L(mm)	Rated ripple (Arms)	tan δ	Leakage Current (mA)	Code
1000	35 × 80	2.4	0.15	1.50	LNR2E102MSE
1500	35 × 100	3.0	0.15	1.83	LNR2E152MSE
2200	51 × 80	4.0	0.15	2.22	LNR2E222MSE
3300	51 × 100	5.4	0.15	2.72	LNR2E332MSE
4700	63.5 × 100	7.3	0.20	3.25	LNR2E472MSE
6800	63.5 × 120	8.9	0.20	3.91	LNR2E682MSE
10000	76.2 × 120	11.8	0.20	4.74	LNR2E103MSE
15000	90 × 140	16.4	0.25	5.00	LNR2E153MSE
22000	90 × 170	17.9	0.25	5.00	LNR2E223MSE
33000	90 × 220	19.7	0.25	5.00	LNR2E333MSE
47000	100 × 250	21.2	0.25	5.00	LNR2E473MSE

Rated ripple current (Arms) at 85°C, 120Hz

### ● Frequency coefficient of rated ripple current

Frequency (Hz)		60	120	360	1k	10k or more
Coeff.	10 to 100V	0.90	1.00	1.08	1.15	1.15
	160 to 250V	0.88	1.00	1.08	1.15	1.20

# ALUMINUM ELECTROLYTIC CAPACITORS

# LNx

Screw Terminal Type, 85°C  
High ripple longer life.

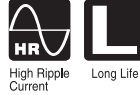

- Suited for use in industrial power supplies for inverter circuitry, etc.
- High ripple current, extra-high voltage application.
- High reliability, long life for 20,000 hours application of rated ripple current at +85°C.
- Extended range up to φ100 × 250L size.
- Flame retardant electrolyte type available.
- Compliant to the RoHS directive (2011/65/EU, (EU)2015/863).

LQR



LNx

Long life LNY



## Specifications

Item	Performance Characteristics
Category Temperature Range	- 25 to +85°C
Rated Voltage Range	350 to 630V
Rated Capacitance Range	1000 to 27000μF
Capacitance Tolerance	±20% at 120Hz, 20°C
Leakage Current	After 5 minutes' application of rated voltage, leakage current is not more than $3\sqrt{CV}$ (μA) or 5 mA, whichever is smaller (at 20°C). [C: Rated Capacitance(μF), V: Voltage (V)]
Tangent of loss angle (tan δ)	See refer to next page (Measurement frequency : 120Hz at 20°C)
Stability at Low Temperature	Rated voltage (V) 350 to 630 Impedance ratio ZT/Z20(MAX.) Z - 25°C / Z+20°C 8
	Measurement frequency : 120Hz
Endurance	The specifications listed at right shall be met when the capacitors are restored to 20°C after the standard ripple current is applied for 20000 hours at 85°C, the peak voltage shall not exceed the rated voltage.(2000 hours at 85°C for the parts rated at 630V, 5000 hours at 85°C for the parts rated at 500V and 550V) The specifications listed at right shall be met when the capacitors are restored to 20°C after D.C. bias plus rated ripple current is applied for 5000 hours at 85°C, the peak voltage shall not exceed the rated voltage.
	Capacitance change Within ±20% of the initial capacitance value
	tan δ 300% or less than the initial specified value
	Leakage current Less than or equal to the initial specified value
Shelf Life	After storing the capacitors under no load at 85°C for 1000 hours and then performing voltage treatment based on JIS C 5101-4 clause 4.1 at 20°C, they shall meet the specified values for the endurance characteristics listed above.
Marking	Printed with white color letter on black sleeve.

## Drawing

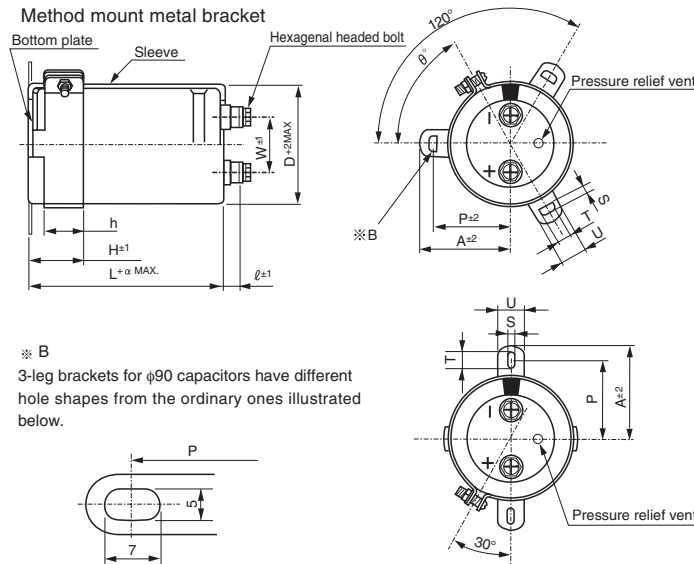

※ B  
3-leg brackets for φ90 capacitors have different hole shapes from the ordinary ones illustrated below.

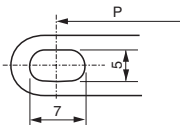

## Type numbering system (Example : 450V 2200μF)

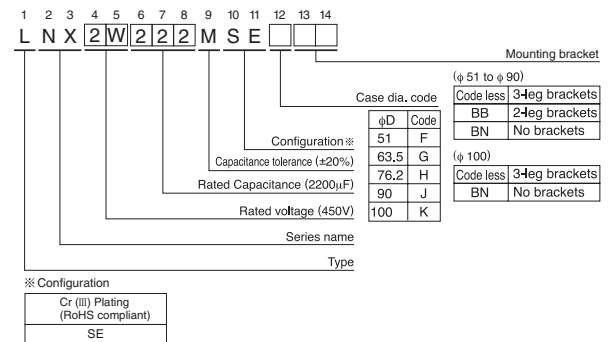

Please refer to the Guidelines for Aluminum Electrolytic Capacitors for dimensions information.

※ Please contact to us if PVCless products are required.

### ● Dimension of terminal pitch (W) and length (ℓ) and Nominal dia. of bolt (mm)

φD	W	ℓ	α	Nominal dia. of bolt
51	22.0	6	3	M5
63.5	28.6	6	3	M5
76.2	31.8	6	3	M5
90	31.8	6	3	M5
100	41.5	10	4	M8

### ● Dimensions of mounting bracket (mm)

Symbol	Leg shape	3-Leg					2-Leg			
		51	63.5	76.2	90	100	51	63.5	76.2	90
P	φD	32.5	38.1	44.5	50.8	56.3	33.2	40.5	46.5	53
A		38.5	43	49.2	58.5	62	40	46.5	53	59
T		7.5	8.0	7.0	8.0	8.0	6.0	7.0	6.0	6.0
S		5.0	5.0	5.0	5.0	5.0	4.5	4.5	4.5	4.5
U		12	14	14	18	16	14	14	14	14
θ°		60	60	60	60	60	30	30	30	30
H		20	25	30	35	36	25	35	35	35
h		15	20	24	25	30	15	20	20	20

● Dimension table in next page.

LNX

■ Dimensions

350V (2V)						
Cap. (μF)	Size φD × L(mm)	Standard ripple (Arms) <sup>1</sup>	Rated ripple (Arms) <sup>2</sup>	tan δ	Leakage Current (mA)	Code
1000	51 × 60	3.5	4.6	0.2	1.77	LNX2V102MSEF
1200	51 × 70	4.2	5.3	0.2	1.94	LNX2V122MSEF
1500	51 × 80	4.9	6.3	0.2	2.17	LNX2V152MSEF
1800	51 × 90	5.6	7.3	0.2	2.38	LNX2V182MSEF
2200	51 × 110	6.7	8.8	0.2	2.63	LNX2V222MSEF
2700	51 × 130	8.0	10.3	0.2	2.91	LNX2V272MSEF
	63.5 × 90	7.7	9.9	0.2	2.91	LNX2V272MSEG
3300	51 × 150	9.2	12.1	0.2	3.22	LNX2V332MSEF
	63.5 × 100	9.0	11.8	0.2	3.22	LNX2V332MSEG
3900	63.5 × 110	10.4	12.5	0.2	3.50	LNX2V392MSEG
	76.2 × 90	10.3	12.2	0.2	3.50	LNX2V392MSEH
4700	63.5 × 130	12.0	14.8	0.2	3.84	LNX2V472MSEG
	76.2 × 100	11.9	14.0	0.2	3.84	LNX2V472MSEH
5600	63.5 × 150	14.0	17.0	0.2	4.20	LNX2V562MSEG
	76.2 × 110	13.5	16.4	0.2	4.20	LNX2V562MSEH
6800	63.5 × 170	16.3	19.6	0.2	4.62	LNX2V682MSEG
	76.2 × 130	16.0	19.1	0.2	4.62	LNX2V682MSEH
8200	76.2 × 150	18.7	22.0	0.2	5.00	LNX2V822MSEH
	90 × 130	18.2	21.4	0.2	5.00	LNX2V822MSEJ
10000	76.2 × 170	21.8	25.5	0.2	5.00	LNX2V103MSEH
	90 × 150	21.3	25.3	0.2	5.00	LNX2V103MSEJ
12000	76.2 × 190	25.1	29.1	0.2	5.00	LNX2V123MSEH
	90 × 150	24.8	28.8	0.2	5.00	LNX2V123MSEJ
15000	90 × 190	29.0	36.0	0.2	5.00	LNX2V153MSEJ
18000	90 × 220	32.4	39.7	0.2	5.00	LNX2V183MSEJ
22000	100 × 220	38.0	43.2	0.2	5.00	LNX2V223MSEK
27000	100 × 250	42.0	47.0	0.2	5.00	LNX2V273MSEK

400V (2G)						
Cap. (μF)	Size φD × L(mm)	Standard ripple (Arms) <sup>1</sup>	Rated ripple (Arms) <sup>2</sup>	tan δ	Leakage Current (mA)	Code
1000	51 × 70	3.8	5.0	0.2	1.89	LNX2G102MSEF
1200	51 × 80	4.5	5.8	0.2	2.07	LNX2G122MSEF
1500	51 × 100	5.3	6.8	0.2	2.32	LNX2G152MSEF
1800	51 × 110	6.0	8.2	0.2	2.54	LNX2G182MSEF
2200	51 × 130	7.0	9.3	0.2	2.81	LNX2G222MSEF
	63.5 × 90	6.8	8.9	0.2	2.81	LNX2G222MSEG
2700	63.5 × 110	8.2	10.8	0.2	3.11	LNX2G272MSEG
	76.2 × 90	8.1	10.6	0.2	3.11	LNX2G272MSEH
3300	63.5 × 130	9.6	12.9	0.2	3.44	LNX2G332MSEG
	76.2 × 100	9.3	12.4	0.2	3.44	LNX2G332MSEH
3900	63.5 × 150	11.0	14.4	0.2	3.74	LNX2G392MSEG
	76.2 × 100	10.5	13.9	0.2	3.74	LNX2G392MSEH
4700	63.5 × 170	12.6	16.6	0.2	4.11	LNX2G472MSEG
	76.2 × 130	12.3	16.0	0.2	4.11	LNX2G472MSEH
5600	63.5 × 190	14.7	18.8	0.2	4.49	LNX2G562MSEG
	76.2 × 150	14.3	18.3	0.2	4.49	LNX2G562MSEH
6800	76.2 × 170	16.7	21.2	0.2	4.94	LNX2G682MSEH
	90 × 130	16.3	20.7	0.2	4.94	LNX2G682MSEJ
8200	76.2 × 190	19.3	24.1	0.2	5.00	LNX2G822MSEH
	90 × 150	19.0	23.7	0.2	5.00	LNX2G822MSEJ
10000	76.2 × 220	22.7	28.3	0.2	5.00	LNX2G103MSEH
	90 × 170	22.2	28.0	0.2	5.00	LNX2G103MSEJ
12000	90 × 190	25.5	31.9	0.2	5.00	LNX2G123MSEJ
15000	100 × 190	29.6	37.0	0.2	5.00	LNX2G153MSEK
18000	100 × 220	33.0	40.5	0.2	5.00	LNX2G183MSEK
22000	100 × 250	41.4	44.7	0.2	5.00	LNX2G223MSEK

450V (2W)						
Cap. (μF)	Size φD × L(mm)	Standard ripple (Arms) <sup>1</sup>	Rated ripple (Arms) <sup>2</sup>	tan δ	Leakage Current (mA)	Code
1000	51 × 80	4.0	5.2	0.2	2.01	LNX2W102MSEF
1200	51 × 100	4.7	6.3	0.2	2.20	LNX2W122MSEF
1500	51 × 110	5.4	7.3	0.2	2.46	LNX2W152MSEF
1800	51 × 130	6.4	8.7	0.2	2.70	LNX2W182MSEF
	63.5 × 90	6.1	7.6	0.2	2.70	LNX2W182MSEG
2200	63.5 × 110	7.2	9.6	0.2	2.98	LNX2W222MSEG
	76.2 × 90	7.1	9.4	0.2	2.98	LNX2W222MSEH
2700	63.5 × 130	8.6	11.3	0.2	3.30	LNX2W272MSEG
	76.2 × 100	8.3	11.0	0.2	3.30	LNX2W272MSEH
3300	63.5 × 150	10.0	13.3	0.2	3.65	LNX2W332MSEG
	76.2 × 110	9.7	12.9	0.2	3.65	LNX2W332MSEH
3900	63.5 × 170	11.4	15.1	0.2	3.97	LNX2W392MSEG
	76.2 × 130	11.2	14.6	0.2	3.97	LNX2W392MSEH
4700	63.5 × 190	13.0	17.3	0.2	4.36	LNX2W472MSEG
	76.2 × 150	12.9	16.9	0.2	4.36	LNX2W472MSEH
5600	76.2 × 170	15.4	19.4	0.2	4.76	LNX2W562MSEH
	90 × 150	15.3	19.1	0.2	4.76	LNX2W562MSEJ
6800	76.2 × 190	17.3	22.0	0.2	5.00	LNX2W682MSEH
	90 × 150	17.1	21.6	0.2	5.00	LNX2W682MSEJ
8200	76.2 × 220	20.3	25.7	0.2	5.00	LNX2W822MSEH
	90 × 170	19.8	25.4	0.2	5.00	LNX2W822MSEJ
10000	90 × 190	23.0	29.6	0.2	5.00	LNX2W103MSEJ
12000	90 × 220	26.9	33.5	0.2	5.00	LNX2W123MSEJ
15000	100 × 220	31.1	38.0	0.2	5.00	LNX2W153MSEK
18000	100 × 250	37.0	41.3	0.2	5.00	LNX2W183MSEK

500V (2H)						
Cap. (μF)	Size φD × L(mm)	Standard ripple (Arms) <sup>1</sup>	Rated ripple (Arms) <sup>2</sup>	tan δ	Leakage Current (mA)	Code
1000	51 × 110	4.2	—	0.2	2.12	LNX2H102MSEF
1200	63.5 × 90	4.8	—	0.2	2.32	LNX2H122MSEG
1500	63.5 × 90	5.5	—	0.2	2.59	LNX2H152MSEG
1800	63.5 × 110	6.5	—	0.2	2.84	LNX2H182MSEG
2200	63.5 × 130	7.7	—	0.2	3.14	LNX2H222MSEG
2700	76.2 × 110	8.8	—	0.2	3.48	LNX2H272MSEH
3300	76.2 × 130	10.4	—	0.2	3.85	LNX2H332MSEH
3900	76.2 × 150	12.1	—	0.2	4.18	LNX2H392MSEH
4700	90 × 130	13.7	—	0.2	4.59	LNX2H472MSEJ
5600	90 × 150	15.9	—	0.2	5.00	LNX2H562MSEJ
6800	90 × 170	18.5	—	0.2	5.00	LNX2H682MSEJ
8200	90 × 190	21.4	—	0.2	5.00	LNX2H822MSEJ
10000	100 × 190	23.8	—	0.2	5.00	LNX2H103MSEK
12000	100 × 220	27.8	—	0.2	5.00	LNX2H123MSEK

Ripple current (Arms) at 85°C 120Hz

## LNx

### ■ Dimensions

550V (2L)						
Cap. (μF)	Size φD × L(mm)	Standard ripple (Arms) <sup>*1</sup>	Rated ripple (Arms) <sup>*2</sup>	tan δ	Leakage Current (mA)	Code
1000	51 × 130	4.3	—	0.2	2.22	LNx2L102MSEF
1200	63.5 × 110	5.0	—	0.2	2.43	LNx2L122MSEG
1500	63.5 × 130	6.0	—	0.2	2.72	LNx2L152MSEG
1800	76.2 × 110	6.7	—	0.2	2.98	LNx2L182MSEH
2200	76.2 × 130	8.0	—	0.2	3.30	LNx2L222MSEH
2700	76.2 × 150	9.4	—	0.2	3.65	LNx2L272MSEH
3300	76.2 × 170	11.0	—	0.2	4.04	LNx2L332MSEH
3900	90 × 150	12.5	—	0.2	4.39	LNx2L392MSEJ
4700	90 × 170	14.5	—	0.2	4.82	LNx2L472MSEJ
5600	90 × 190	16.6	—	0.2	5.00	LNx2L562MSEJ
6800	90 × 220	19.5	—	0.2	5.00	LNx2L682MSEJ
8200	100 × 220	21.6	—	0.2	5.00	LNx2L822MSEK
10000	100 × 250	25.2	—	0.2	5.00	LNx2L103MSEK

630V(2J)						
Cap. (μF)	Size φD × L(mm)	Standard ripple (Arms) <sup>*1</sup>	Rated ripple (Arms) <sup>*2</sup>	tan δ	Leakage Current (mA)	Code
1000	63.5 × 130	5.9	—	0.3	2.38	LNx2J102MSEG
1200	76.2 × 110	6.7	—	0.3	2.60	LNx2J122MSEH
1500	76.2 × 130	8.1	—	0.3	2.91	LNx2J152MSEH
1800	76.2 × 150	9.6	—	0.3	3.19	LNx2J182MSEH
2200	90 × 130	10.7	—	0.3	3.53	LNx2J222MSEJ
2700	90 × 150	12.6	—	0.3	3.91	LNx2J272MSEJ
3300	90 × 170	14.7	—	0.3	4.32	LNx2J332MSEJ
3900	90 × 190	17.3	—	0.3	4.70	LNx2J392MSEJ
4700	100 × 220	21.4	—	0.3	5.00	LNx2J472MSEK
5600	100 × 250	24.7	—	0.3	5.00	LNx2J562MSEK

Ripple current (Arms) at 85°C 120Hz

### ● Frequency coefficient of rated ripple current

Frequency (Hz)	50	60	120	360	1k	10k or more
Coefficient	0.80	0.82	1.00	1.20	1.35	1.40

- (※ 1) • Standard ripple current:  
Ripple current value allowable for the life time of 20,000 hours at 85°C.  
(5,000 hours at 85°C for the voltage rating of 500V and 550V. 2,000 hours at 85°C for the voltage rating of 630V)
  - (※ 2) • Maximum rated ripple current:  
Ripple current value allowable for the life time of 5,000 hours at 85°C.
  - 3-leg bracket is furnished as standard.  
In case no-bracket or 2-leg bracket required, please put BN or BB at the end of type number.
- Ex. 3-leg bracket LNx2G472MSEH  
2-leg bracket LNx2G472MSEHBB  
No bracket LNx2G472MSEHBN
- Flame-retardant type electrolyte is also available.  
Please contact to Nichicon representative for the rated ripple current value.

# ALUMINUM ELECTROLYTIC CAPACITORS

# LNK

Screw Terminal Type, 85°C Smaller-sized



- Load life 5000 hours application of ripple current at 85°C.
- Compliant to the RoHS directive (2011/65/EU, (EU)2015/863).



## Specifications

Item	Performance Characteristics	
Category Temperature Range	- 25 to +85°C	
Rated Voltage Range	350 to 500V	
Rated Capacitance Range	1000 to 18000μF	
Capacitance Tolerance	±20% at 120Hz, 20°C	
Leakage Current	After 5 minutes' application of rated voltage, leakage current is not more than $3\sqrt{CV}$ (μA) or 5 mA, whichever is smaller (at 20°C). [C: Rated Capacitance(μF), V: Voltage (V)]	
Tangent of loss angle (tan δ)	See refer to next page (Measurement frequency : 120Hz at 20°C)	
Stability at Low Temperature	Rated voltage (V)	350 to 500
	Impedance ratio ZT/Z20(MAX.)	Z - 25°C / Z + 20°C 8
Insulation Resistance	The insulation resistance shall be more than 100MΩ at DC 500V application between terminal and bracket.	
Voltage proof	There is no abnormality during AC 2500V 1 minute's application between terminal and bracket.	
Endurance	Capacitance change	Within ±20% of the initial capacitance value
	tan δ	300% or less than the initial specified value
	Leakage current	Less than or equal to the initial specified value
Shelf Life	Capacitance change	Within ±20% of the initial capacitance value
	tan δ	300% or less than the initial specified value
	Leakage current	Less than or equal to the initial specified value
Marking	Printed with white color letter on black sleeve.	

## Drawing

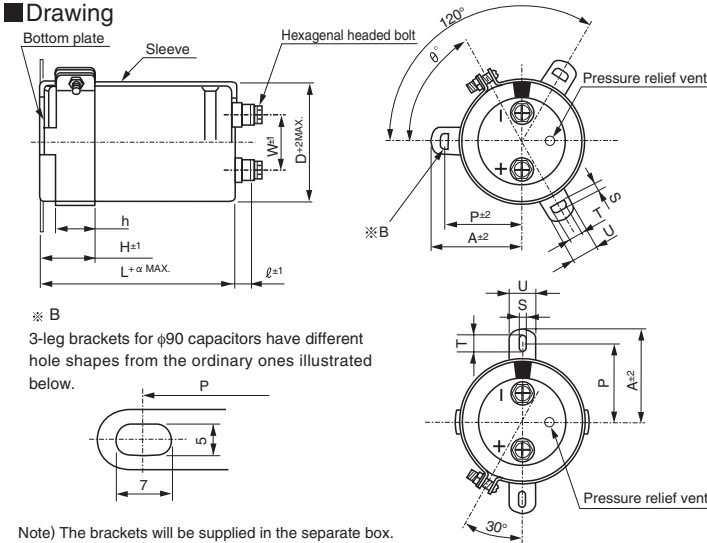

## Type numbering system (Example : 400V 10000μF)

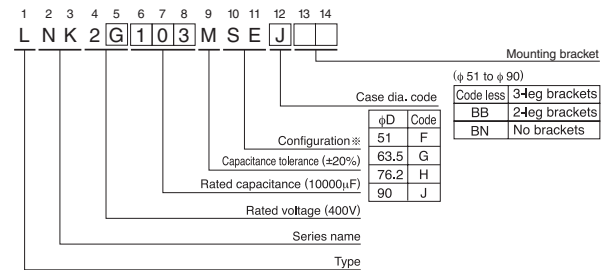

### ※ Configuration

Cr(III) Plating  
(RoHS compliant)  
SE

Please refer to the Guidelines for Aluminum Electrolytic Capacitors for dimensions information.

※Please contact to us if PVCless products are required.

- Flame-retardant type electrolyte is also available. Please contact to Nichicon representative for the rated ripple current value.

- Dimension of terminal pitch (W) and length (ℓ) and Nominal dia. of bolt (mm)

φD	W	ℓ	α	Nominal dia. of bolt
51	22.0	6	3	M 5
63.5	28.6	6	3	M 5
76.2	31.8	6	3	M 5
90	31.8	6	3	M 5

- Frequency coefficient of rated ripple current

Frequency (Hz)	50	60	120	360	1k	10k or more
Coefficient	0.80	0.82	1.00	1.20	1.35	1.40

- Dimensions of mounting bracket (mm)

Symbol	Leg shape φD	3-Leg				2-Leg			
		51	63.5	76.2	90	51	63.5	76.2	90
P		32.5	38.1	44.5	50.8	33.2	40.5	46.5	53
A		38.5	43	49.2	58.5	40	46.5	53	59
T		7.5	8.0	7.0	8.0	6.0	7.0	6.0	6.0
S		5.0	5.0	5.0	5.0	4.5	4.5	4.5	4.5
U		12	14	14	18	14	14	14	14
θ°		60	60	60	60	30	30	30	30
H		20	25	30	35	25	35	35	35
h		15	20	24	25	15	20	20	20

● Dimension table in next page.



## LNK

### ■ Dimensions

350V (2V)					
Cap. (μF)	Size φD × L(mm)	Rated ripple (Arms)	tan δ	Leakage Current (mA)	Code
1000	51 × 60	4.8	0.20	1.77	LNK2V102MSEF
1200	51 × 70	5.5	0.20	1.94	LNK2V122MSEF
1500	51 × 75	6.5	0.20	2.17	LNK2V152MSEF
1800	51 × 90	7.3	0.20	2.38	LNK2V182MSEF
2200	51 × 95	8.2	0.20	2.63	LNK2V222MSEF
2700	51 × 105	9.3	0.20	2.91	LNK2V272MSEF
	63.5 × 85	9.9	0.20	2.91	LNK2V272MSEG
3300	63.5 × 95	11.8	0.20	3.22	LNK2V332MSEG
3900	63.5 × 100	12.8	0.20	3.50	LNK2V392MSEG
	76.2 × 85	13.0	0.20	3.50	LNK2V392MSEH
4700	63.5 × 115	13.8	0.20	3.84	LNK2V472MSEG
	76.2 × 90	14.2	0.20	3.84	LNK2V472MSEH
5600	63.5 × 130	17.3	0.20	4.20	LNK2V562MSEG
	76.2 × 100	16.8	0.20	4.20	LNK2V562MSEH
6800	63.5 × 155	19.6	0.20	4.62	LNK2V682MSEG
	76.2 × 115	19.0	0.20	4.62	LNK2V682MSEH
8200	63.5 × 190	22.6	0.20	5.00	LNK2V822MSEG
	76.2 × 130	21.0	0.20	5.00	LNK2V822MSEH
	90 × 120	24.0	0.20	5.00	LNK2V822MSEJ
10000	76.2 × 155	25.1	0.20	5.00	LNK2V103MSEH
	90 × 140	25.9	0.20	5.00	LNK2V103MSEJ
12000	90 × 150	28.4	0.20	5.00	LNK2V123MSEJ

400V (2G)					
Cap. (μF)	Size φD × L(mm)	Rated ripple (Arms)	tan δ	Leakage Current (mA)	Code
1000	51 × 65	5.0	0.20	1.89	LNK2G102MSEF
1200	51 × 75	5.8	0.20	2.07	LNK2G122MSEF
1500	51 × 90	6.8	0.20	2.32	LNK2G152MSEF
1800	51 × 95	7.3	0.20	2.54	LNK2G182MSEF
2200	51 × 105	8.8	0.20	2.81	LNK2G222MSEF
	63.5 × 85	8.9	0.20	2.81	LNK2G222MSEG
2700	51 × 115	10.2	0.20	3.11	LNK2G272MSEF
	63.5 × 90	10.8	0.20	3.11	LNK2G272MSEG
	76.2 × 75	10.6	0.20	3.11	LNK2G272MSEH
3300	63.5 × 95	11.8	0.20	3.44	LNK2G332MSEG
	76.2 × 90	12.0	0.20	3.44	LNK2G332MSEH
3900	63.5 × 115	12.8	0.20	3.74	LNK2G392MSEG
	76.2 × 95	13.0	0.20	3.74	LNK2G392MSEH
4700	63.5 × 130	14.8	0.20	4.11	LNK2G472MSEG
	76.2 × 110	15.0	0.20	4.11	LNK2G472MSEH
5600	63.5 × 155	17.0	0.20	4.49	LNK2G562MSEG
	76.2 × 115	16.5	0.20	4.49	LNK2G562MSEH
6800	63.5 × 190	20.6	0.20	4.94	LNK2G682MSEG
	76.2 × 130	19.2	0.20	4.94	LNK2G682MSEH
	90 × 120	20.7	0.20	4.94	LNK2G682MSEJ
8200	76.2 × 155	22.7	0.20	5.00	LNK2G822MSEH
	90 × 120	22.9	0.20	5.00	LNK2G822MSEJ
10000	76.2 × 170	26.2	0.20	5.00	LNK2G103MSEH
	90 × 130	24.2	0.20	5.00	LNK2G103MSEJ
12000	90 × 155	28.5	0.20	5.00	LNK2G123MSEJ
15000	90 × 190	34.8	0.20	5.00	LNK2G153MSEJ
18000	90 × 235	41.2	0.20	5.00	LNK2G183MSEJ

450V (2W)					
Cap. (μF)	Size φD × L(mm)	Rated ripple (Arms)	tan δ	Leakage Current (mA)	Code
1000	51 × 75	5.2	0.20	2.01	LNK2W102MSEF
1200	51 × 85	6.3	0.20	2.20	LNK2W122MSEF
1500	51 × 95	6.4	0.20	2.46	LNK2W152MSEF
1800	51 × 105	7.6	0.20	2.70	LNK2W182MSEF
	63.5 × 85	7.6	0.20	2.70	LNK2W182MSEG
2200	63.5 × 90	9.0	0.20	2.98	LNK2W222MSEG
	76.2 × 85	9.4	0.20	2.98	LNK2W222MSEH
2700	63.5 × 95	10.5	0.20	3.30	LNK2W272MSEG
	76.2 × 90	11.0	0.20	3.30	LNK2W272MSEH
3300	63.5 × 115	12.1	0.20	3.65	LNK2W332MSEG
	76.2 × 100	12.9	0.20	3.65	LNK2W332MSEH
3900	76.2 × 110	14.2	0.20	3.97	LNK2W392MSEH
4700	63.5 × 155	15.6	0.20	4.36	LNK2W472MSEG
	76.2 × 115	15.1	0.20	4.36	LNK2W472MSEH
5600	63.5 × 190	18.7	0.20	4.76	LNK2W562MSEG
	90 × 120	18.6	0.20	4.76	LNK2W562MSEJ
6800	76.2 × 155	20.7	0.20	5.00	LNK2W682MSEH
	90 × 125	20.0	0.20	5.00	LNK2W682MSEJ
8200	76.2 × 190	19.1	0.20	5.00	LNK2W822MSEH
12000	90 × 190	29.7	0.20	5.00	LNK2W123MSEJ
15000	90 × 235	35.9	0.20	5.00	LNK2W153MSEJ

500V (2H)					
Cap. (μF)	Size φD × L(mm)	Rated ripple (Arms)	tan δ	Leakage Current (mA)	Code
1000	51 × 100	4.2	0.20	2.12	LNK2H102MSEF
	63.5 × 80	4.2	0.20	2.12	LNK2H102MSEG
1200	51 × 115	6.2	0.20	2.32	LNK2H122MSEF
	63.5 × 85	6.3	0.20	2.32	LNK2H122MSEG
1500	51 × 130	7.3	0.20	2.59	LNK2H152MSEF
	63.5 × 90	7.1	0.20	2.59	LNK2H152MSEG
1800	63.5 × 105	8.3	0.20	2.84	LNK2H182MSEG
2200	63.5 × 120	9.6	0.20	3.14	LNK2H222MSEG
2700	76.2 × 110	10.7	0.20	3.48	LNK2H272MSEH
3300	76.2 × 115	12.4	0.20	3.85	LNK2H332MSEH
3900	76.2 × 150	14.4	0.20	4.18	LNK2H392MSEH
	90 × 120	14.4	0.20	4.18	LNK2H392MSEJ
4700	76.2 × 170	16.5	0.20	4.59	LNK2H472MSEH
	90 × 130	15.8	0.20	4.59	LNK2H472MSEJ
5600	76.2 × 190	19.0	0.20	5.00	LNK2H562MSEH
	90 × 150	18.6	0.20	5.00	LNK2H562MSEJ
6800	90 × 170	21.2	0.20	5.00	LNK2H682MSEJ
8200	90 × 190	24.5	0.20	5.00	LNK2H822MSEJ
10000	90 × 235	29.3	0.20	5.00	LNK2H103MSEJ

Rated ripple current (Arms) at 85°C 120Hz

# ALUMINUM ELECTROLYTIC CAPACITORS

# LNC

Screw Terminal Type, 85°C Smaller-sized  
Higher ripple current



- Suited for use in industrial power supplies for inverter circuitry, etc.
- Load life 5000 hours application of ripple current at 85°C.
- Smaller sized / High ripple current than LNX, LNK.
- Coped with loading of high speed charge-discharge.
- Suited for high frequency regenerative voltage for AC servomotor, general inverter.
- Compliant to the RoHS directive (2011/65/EU, (EU)2015/863).

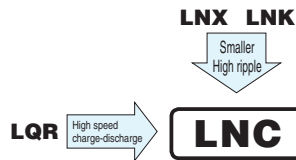

## Specifications

Item	Performance Characteristics		
Category Temperature Range	- 40 to +85°C		
Rated Voltage Range	350 to 500V		
Rated Capacitance Range	1000 to 22000μF		
Capacitance Tolerance	±20% at 120Hz, 20°C		
Leakage Current	After 5 minutes' application of rated voltage, leakage current is not more than $3\sqrt{CV}$ (μA) or 5 mA, whichever is smaller (at 20°C). [C: Rated Capacitance(μF), V: Voltage (V)]		
Tangent of loss angle (tan δ)	See refer to next page (Measurement frequency: 120Hz at 20°C)		
Stability at Low Temperature	Rated voltage (V)	350 to 500	
	Impedance ratio ZT/Z20(MAX.)	Z - 40°C / Z+20°C 8	
Measurement frequency: 120Hz			
Insulation Resistance	The insulation resistance shall be more than 100MΩ at DC 500V application between terminal and bracket.		
Voltage proof	There is no abnormality during AC 2500V 1 minute's application between terminal and bracket.		
Endurance	The specifications listed at right shall be met when the capacitors are restored to 20°C after D.C. bias plus rated ripple current is applied for 5000 hours at 85°C, the peak voltage shall not exceed the rated voltage.	Capacitance change	Within ±20% of the initial capacitance value
		tan δ	200% or less than the initial specified value
		Leakage current	Less than or equal to the initial specified value
Shelf Life	After storing the capacitors under no load at 85°C for 1000 hours and then performing voltage treatment based on JIS C 5101-4 clause 4.1 at 20°C, they shall meet the requirements listed at right.	Capacitance change	Within ±20% of the initial capacitance value
		tan δ	200% or less than the initial specified value
		Leakage current	Less than or equal to the initial specified value
Endurance of charge-discharge behavior	After an application of charge-discharge voltage for 50million times (charge-discharge voltage difference(ΔV)=rated voltage × 0.3, cycle 3Hz) capacitors shall meet the characteristics requirement listed at right.	Capacitance change	Within ±20% of the initial capacitance value
		tan δ	200% or less than the initial specified value
		Leakage current	Less than or equal to the initial specified value
Marking	Printed with white color letter on black sleeve.		

## Drawing

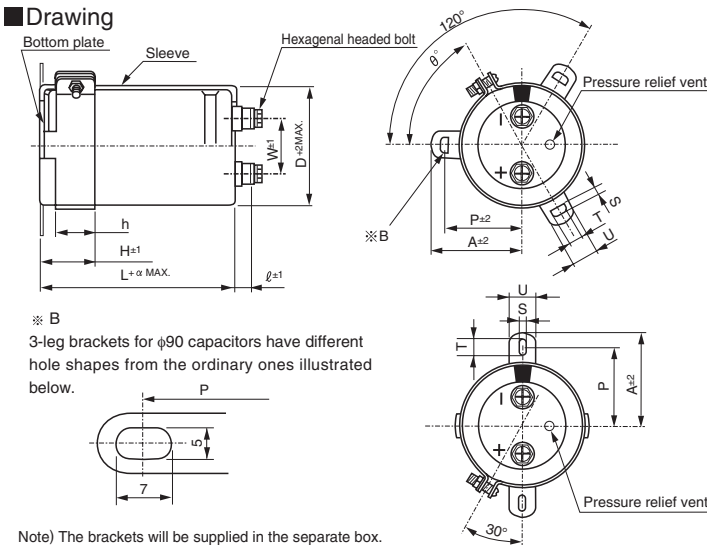

Note) The brackets will be supplied in the separate box.

## Type numbering system (Example : 400V 10000μF)

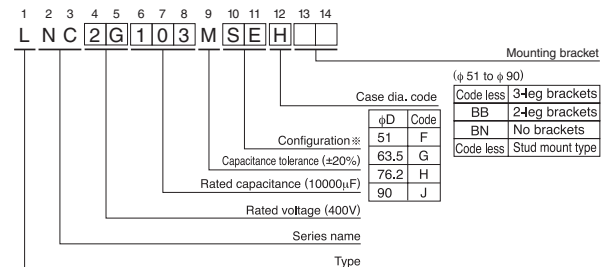

### ※ Configuration

SE	standard specifications
TE	stud mount type

Please refer to the Guidelines for Aluminum Electrolytic Capacitors for dimensions information.

※ Please contact to us if PVCless products are required.

### • Dimension of terminal pitch (W) and length (ℓ) and Nominal dia. of bolt (mm)

φD	W	ℓ	α	Nominal dia. of bolt
51	22.0	6	3	M 5
63.5	28.6	6	3	M 5
76.2	31.8	6	3	M 5
90	31.8	6	3	M 5

About product of stud bolt  
 • Nylon nut and nylon washer attachment are shown in the standard specifications.  
 (Please refer to the Guidelines for Aluminum Electrolytic Capacitors)  
 • It is not attached to the bracket.  
 • Field 13 and 14 become blank in Type number system.

### • Dimensions of mounting bracket (mm)

Symbol	Leg shape φD	3-Leg				2-Leg			
		51	63.5	76.2	90	51	63.5	76.2	90
P		32.5	38.1	44.5	50.8	33.2	40.5	46.5	53
A		38.5	43	49.2	58.5	40	46.5	53	59
T		7.5	8.0	7.0	8.0	6.0	7.0	6.0	6.0
S		5.0	5.0	5.0	5.0	4.5	4.5	4.5	4.5
U		12	14	14	18	14	14	14	14
θ °		60	60	60	60	30	30	30	30
H		20	25	30	35	25	35	35	35
h		15	20	24	25	15	20	20	20

• Dimension table in next page.

# LNC

■ Dimensions

350V(2V)					
Cap. (μF)	Size φD × L(mm)	Rated ripple (Arms)	tan δ	Leakage Current (mA)	Code
1000	51 × 55	8.4	0.20	1.77	LNC2V102MSEF
1200	51 × 60	8.6	0.20	1.94	LNC2V122MSEF
1500	51 × 65	9.3	0.20	2.17	LNC2V152MSEF
1800	51 × 75	10.3	0.20	2.38	LNC2V182MSEF
2200	51 × 85	11.9	0.20	2.63	LNC2V222MSEF
2700	51 × 95	13.3	0.20	2.92	LNC2V272MSEF
	63.5 × 70	13.7	0.20	2.92	LNC2V272MSEG
3300	51 × 115	13.6	0.20	3.22	LNC2V332MSEF
	63.5 × 80	14.0	0.20	3.22	LNC2V332MSEG
3900	63.5 × 85	14.9	0.20	3.50	LNC2V392MSEG
	76.2 × 70	14.3	0.20	3.50	LNC2V392MSEH
4700	63.5 × 100	16.4	0.20	3.85	LNC2V472MSEG
	76.2 × 80	15.7	0.20	3.85	LNC2V472MSEH
5600	63.5 × 115	18.1	0.20	4.20	LNC2V562MSEG
	76.2 × 90	17.6	0.20	4.20	LNC2V562MSEH
6800	63.5 × 135	20.3	0.20	4.63	LNC2V682MSEG
	76.2 × 100	19.7	0.20	4.63	LNC2V682MSEH
8200	76.2 × 115	22.2	0.20	5.00	LNC2V822MSEH
	90 × 90	24.2	0.20	5.00	LNC2V822MSEJ
10000	76.2 × 135	25.2	0.20	5.00	LNC2V103MSEH
	90 × 100	27.1	0.20	5.00	LNC2V103MSEJ
12000	76.2 × 155	28.2	0.20	5.00	LNC2V123MSEH
	90 × 120	30.1	0.20	5.00	LNC2V123MSEJ
15000	90 × 145	35.4	0.20	5.00	LNC2V153MSEJ
18000	90 × 165	39.2	0.20	5.00	LNC2V183MSEJ
22000	90 × 205	43.4	0.20	5.00	LNC2V223MSEJ

400V(2G)					
Cap. (μF)	Size φD × L(mm)	Rated ripple (Arms)	tan δ	Leakage Current (mA)	Code
1000	51 × 60	8.6	0.20	1.90	LNC2G102MSEF
1200	51 × 65	9.3	0.20	2.08	LNC2G122MSEF
1500	51 × 80	10.8	0.20	2.32	LNC2G152MSEF
1800	51 × 85	12.0	0.20	2.55	LNC2G182MSEF
2200	51 × 100	13.0	0.20	2.81	LNC2G222MSEF
	63.5 × 70	12.8	0.20	2.81	LNC2G222MSEG
2700	63.5 × 80	14.5	0.20	3.12	LNC2G272MSEG
	76.2 × 65	14.3	0.20	3.12	LNC2G272MSEH
3300	63.5 × 90	14.9	0.20	3.45	LNC2G332MSEG
	76.2 × 70	15.3	0.20	3.45	LNC2G332MSEH
3900	63.5 × 100	16.5	0.20	3.75	LNC2G392MSEG
	76.2 × 80	17.1	0.20	3.75	LNC2G392MSEH
4700	63.5 × 120	18.8	0.20	4.11	LNC2G472MSEG
	76.2 × 90	18.3	0.20	4.11	LNC2G472MSEH
5600	63.5 × 135	20.9	0.20	4.49	LNC2G562MSEG
	76.2 × 100	20.2	0.20	4.49	LNC2G562MSEH
6800	63.5 × 165	23.8	0.20	4.95	LNC2G682MSEG
	76.2 × 120	23.1	0.20	4.95	LNC2G682MSEH
8200	90 × 90	26.3	0.20	4.95	LNC2G682MSEJ
	76.2 × 145	26.1	0.20	5.00	LNC2G822MSEH
10000	90 × 105	29.5	0.20	5.00	LNC2G822MSEJ
	76.2 × 165	29.5	0.20	5.00	LNC2G103MSEH
12000	90 × 120	33.2	0.20	5.00	LNC2G103MSEJ
	90 × 145	37.1	0.20	5.00	LNC2G123MSEJ
15000	90 × 185	42.9	0.20	5.00	LNC2G153MSEJ
18000	90 × 205	48.2	0.20	5.00	LNC2G183MSEJ

450V(2W)					
Cap. (μF)	Size φD × L(mm)	Rated ripple (Arms)	tan δ	Leakage Current (mA)	Code
1000	51 × 70	9.3	0.20	2.01	LNC2W102MSEF
1200	51 × 80	9.9	0.20	2.20	LNC2W122MSEF
1500	51 × 90	10.4	0.20	2.46	LNC2W152MSEF
1800	51 × 105	11.5	0.20	2.70	LNC2W182MSEF
	63.5 × 70	11.9	0.20	2.70	LNC2W182MSEG
2200	63.5 × 85	12.3	0.20	2.98	LNC2W222MSEG
	76.2 × 65	12.5	0.20	2.98	LNC2W222MSEH
2700	63.5 × 90	13.7	0.20	3.31	LNC2W272MSEG
	76.2 × 75	13.7	0.20	3.31	LNC2W272MSEH
3300	63.5 × 115	15.6	0.20	3.66	LNC2W332MSEG
	76.2 × 85	15.5	0.20	3.66	LNC2W332MSEH
3900	63.5 × 135	17.3	0.20	3.97	LNC2W392MSEG
	76.2 × 90	17.0	0.20	3.97	LNC2W392MSEH
4700	63.5 × 145	19.2	0.20	4.36	LNC2W472MSEG
	76.2 × 115	19.2	0.20	4.36	LNC2W472MSEH
5600	63.5 × 165	21.4	0.20	4.76	LNC2W562MSEG
	76.2 × 135	21.6	0.20	4.76	LNC2W562MSEH
	90 × 95	24.2	0.20	4.76	LNC2W562MSEJ
6800	76.2 × 145	23.8	0.20	5.00	LNC2W682MSEH
	90 × 115	27.5	0.20	5.00	LNC2W682MSEJ
8200	76.2 × 185	27.2	0.20	5.00	LNC2W822MSEH
	90 × 135	30.5	0.20	5.00	LNC2W822MSEJ
10000	90 × 155	34.1	0.20	5.00	LNC2W103MSEJ
12000	90 × 185	38.2	0.20	5.00	LNC2W123MSEJ
15000	90 × 215	43.1	0.20	5.00	LNC2W153MSEJ

500V(2H)					
Cap. (μF)	Size φD × L(mm)	Rated ripple (Arms)	tan δ	Leakage Current (mA)	Code
1000	51 × 85	10.3	0.20	2.12	LNC2H102MSEF
1200	63.5 × 70	10.4	0.20	2.32	LNC2H122MSEG
1500	63.5 × 80	11.6	0.20	2.60	LNC2H152MSEG
1800	63.5 × 90	12.7	0.20	2.85	LNC2H182MSEG
2200	63.5 × 100	14.2	0.20	3.15	LNC2H222MSEG
2700	76.2 × 90	15.8	0.20	3.49	LNC2H272MSEH
3300	76.2 × 105	17.8	0.20	3.85	LNC2H332MSEH
3900	76.2 × 120	19.9	0.20	4.19	LNC2H392MSEH
4700	90 × 105	23.6	0.20	4.60	LNC2H472MSEJ
5600	90 × 120	26.4	0.20	5.00	LNC2H562MSEJ
6800	90 × 145	30.0	0.20	5.00	LNC2H682MSEJ
8200	90 × 165	33.7	0.20	5.00	LNC2H822MSEJ
10000	90 × 205	38.3	0.20	5.00	LNC2H103MSEJ

Rated ripple current (Arms) at 85°C 120Hz

● Frequency coefficient of rated ripple current

Frequency (Hz)	50	60	120	360	1k	10k or more
Coefficient	0.80	0.82	1.00	1.20	1.35	1.40

# ALUMINUM ELECTROLYTIC CAPACITORS

# LQR

Screw Terminal Type,  
85°C High speed charge-discharge

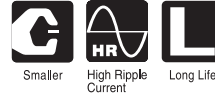

- Suited for high frequency regenerative voltage for AC servomotor, general inverter.
- Suited for equipment used at voltage fluctuating area.
- Suited for rectifier circuit of voltage doubler
- Compliant to the RoHS directive (2011/65/EU, (EU)2015/863).

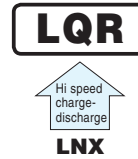

## Specifications

Item	Performance Characteristics	
Category Temperature Range	- 25 to +85°C	
Rated Voltage Range	350 to 450V	
Rated Capacitance Range	680 to 15000μF	
Capacitance Tolerance	±20% at 120Hz, 20°C	
Leakage Current	After 5 minutes' application of rated voltage, leakage current is not more than $3\sqrt{CV}$ (μA) or 5 mA, whichever is smaller (at 20°C). [C: Rated Capacitance(μF), V: Voltage (V)]	
Tangent of loss angle (tan δ)	See refer to next page (Measurement frequency : 120Hz at 20°C)	
Stability at Low Temperature	Rated voltage (V)	350 to 450
	Impedance ratio ZT/Z20(MAX.)	Z - 25°C / Z+20°C 8
Endurance	The specifications listed at right shall be met when the capacitors are restored to 20°C after D.C. bias plus rated ripple current is applied for 5000 hours at 85°C, the peak voltage shall not exceed the rated voltage.	
	Capacitance change	Within ±20% of the initial capacitance value
	tan δ	300% or less than the initial specified value
Shelf Life	After storing the capacitors under no load at 85°C for 1000 hours and then performing voltage treatment based on JIS C 5101-4 clause 4.1 at 20°C, they shall meet the specified value for endurance characteristics listed above.	
	Leakage current	Less than or equal to the initial specified value
	Appearance	There shall be found to remarkable abnormality on the capacitor
Endurance of charge-discharge behavior	After an application of charge-discharge voltage for 20million times (charge-discharge voltage difference(ΔV)=rated voltage × 0.3, cycle 3Hz)capacitors shall meet the characteristics requirement listed at right	
	Capacitance change	Within ±20% of the initial capacitance value
	tan δ	300% or less than the initial specified value
	Leakage current	Less than or equal to the initial specified value
Marking	Printed with white color letter on darkbrown sleeve.	

## Drawing

φ35 Screw terminal type

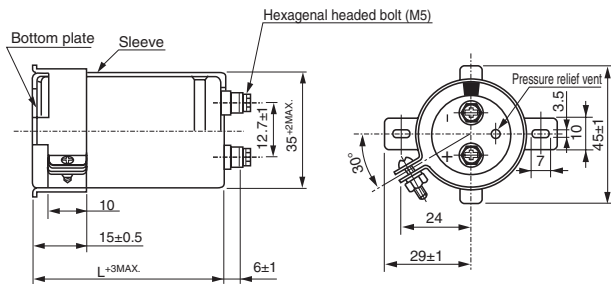

φ51 to 90 Screw terminal type

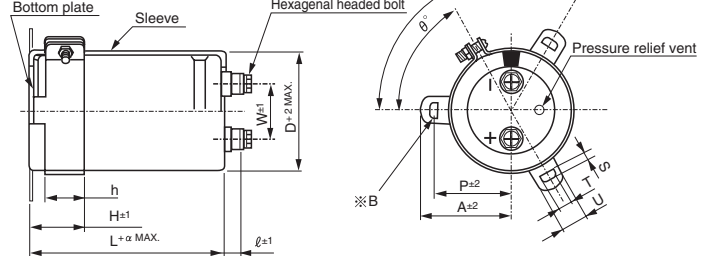

※ B  
3-leg brackets for φ90 capacitors have different hole shapes from the ordinary ones illustrated below.

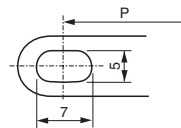

Type numbering system (Example : 400V 1800μF)

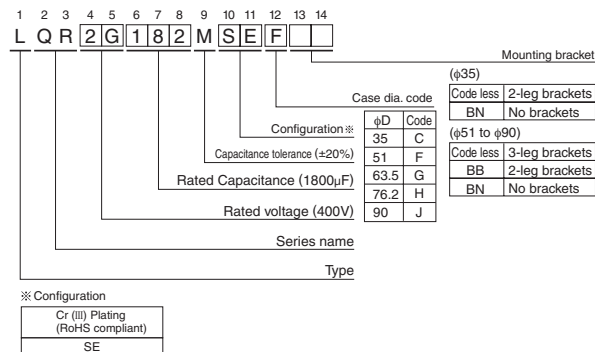

● Dimension of terminal pitch (W) and length (ℓ) and Nominal dia. of bolt (mm)

φD	W	ℓ	α	Nominal dia. of bolt
51	22.0	6	3	M5
63.5	28.6	6	3	M5
76.2	31.8	6	3	M5
90	31.8	6	3	M5

● Dimension of mounting bracket (mm)

Symbol	Leg shape	3-Leg			2-Leg				
		51	63.5	76.2	90	51	63.5	76.2	90
P	φ0	32.5	38.1	44.5	50.8	33.2	40.5	46.5	53
A		38.5	43	49.2	58.5	40	46.5	53	59
T		7.5	8.0	7.0	8.0	6.0	7.0	6.0	6.0
S		5.0	5.0	5.0	5.0	4.5	4.5	4.5	4.5
U		12	14	14	18	14	14	14	14
θ°		60	60	60	60	30	30	30	30
H		20	25	30	35	25	35	35	35
h		15	20	24	25	15	20	20	20

● Dimension table in next page.

Please refer to the Guidelines for Aluminum Electrolytic Capacitors for dimensions information.

※Please contact to us if PVCless products are required.

## LQR

### ■ Dimensions

350V (2V)					
Cap. (μF)	Size φD × L(mm)	Rated ripple (Arms)	tan δ	Leakage Current (mA)	Code
820	35 × 80	3.3	0.15	1.60	LQR2V821MSEC
1000	35 × 100	4.3	0.15	1.77	LQR2V102MSEC
1800	51 × 80	7.2	0.15	2.38	LQR2V182MSEF
2200	51 × 100	9.1	0.15	2.63	LQR2V222MSEF
2700	51 × 110	10.8	0.15	2.91	LQR2V272MSEF
	63.5 × 80	10.6	0.15	2.91	LQR2V272MSEG
3300	51 × 130	12.4	0.15	3.22	LQR2V332MSEF
	63.5 × 90	11.9	0.15	3.22	LQR2V332MSEG
3900	63.5 × 110	14.6	0.15	3.50	LQR2V392MSEG
	76.2 × 80	14.1	0.15	3.50	LQR2V392MSEH
4700	51 × 170	17.0	0.15	3.84	LQR2V472MSEF
	76.2 × 90	16.4	0.15	3.84	LQR2V472MSEH
5600	63.5 × 150	20.4	0.15	4.20	LQR2V562MSEG
	76.2 × 110	19.7	0.15	4.20	LQR2V562MSEH
6800	63.5 × 170	23.5	0.15	4.62	LQR2V682MSEG
	76.2 × 130	22.9	0.15	4.62	LQR2V682MSEH
	90 × 100	22.5	0.15	4.62	LQR2V682MSEJ
8200	63.5 × 190	27.1	0.15	5.00	LQR2V822MSEG
	76.2 × 150	26.4	0.15	5.00	LQR2V822MSEH
10000	76.2 × 170	31.1	0.15	5.00	LQR2V103MSEH
	90 × 130	30.2	0.15	5.00	LQR2V103MSEJ
12000	76.2 × 190	35.7	0.15	5.00	LQR2V123MSEH
15000	90 × 190	40.5	0.15	5.00	LQR2V153MSEJ

400V (2G)					
Cap. (μF)	Size φD × L(mm)	Rated ripple (Arms)	tan δ	Leakage Current (mA)	Code
680	35 × 80	3.2	0.15	1.56	LQR2G681MSEC
820	35 × 100	4.1	0.15	1.71	LQR2G821MSEC
1500	51 × 80	7.5	0.15	2.32	LQR2G152MSEF
1800	51 × 90	9.1	0.15	2.54	LQR2G182MSEF
2200	51 × 110	10.4	0.15	2.81	LQR2G222MSEF
2700	63.5 × 90	11.5	0.15	3.11	LQR2G272MSEG
3300	51 × 150	13.7	0.15	3.44	LQR2G332MSEF
	63.5 × 110	13.2	0.15	3.44	LQR2G332MSEG
3900	63.5 × 130	16.0	0.15	3.74	LQR2G392MSEG
	76.2 × 90	15.3	0.15	3.74	LQR2G392MSEH
4700	63.5 × 150	18.7	0.15	4.11	LQR2G472MSEG
	76.2 × 110	18.3	0.15	4.11	LQR2G472MSEH
5600	63.5 × 170	22.0	0.15	4.49	LQR2G562MSEG
	76.2 × 130	21.4	0.15	4.49	LQR2G562MSEH
6800	76.2 × 150	25.4	0.15	4.94	LQR2G682MSEH
8200	76.2 × 170	28.6	0.15	5.00	LQR2G822MSEH
	90 × 130	27.8	0.15	5.00	LQR2G822MSEJ
10000	90 × 150	32.7	0.15	5.00	LQR2G103MSEJ
12000	90 × 170	37.6	0.15	5.00	LQR2G123MSEJ
15000	90 × 220	43.0	0.15	5.00	LQR2G153MSEJ

450V (2W)					
Cap. (μF)	Size φD × L(mm)	Rated ripple (Arms)	tan δ	Leakage Current (mA)	Code
680	35 × 100	3.5	0.15	1.65	LQR2W681MSEC
820	35 × 110	3.9	0.15	1.82	LQR2W821MSEC
1200	51 × 80	5.2	0.15	2.20	LQR2W122MSEF
1500	51 × 100	6.3	0.15	2.46	LQR2W152MSEF
1800	51 × 110	7.4	0.15	2.70	LQR2W182MSEF
	63.5 × 80	7.9	0.15	2.70	LQR2W182MSEG
2200	51 × 130	8.7	0.15	2.98	LQR2W222MSEF
	63.5 × 100	8.6	0.15	2.98	LQR2W222MSEG
2700	51 × 150	10.2	0.15	3.30	LQR2W272MSEF
	76.2 × 80	10.0	0.15	3.30	LQR2W272MSEH
3300	63.5 × 130	12.4	0.15	3.65	LQR2W332MSEG
	76.2 × 100	11.8	0.15	3.65	LQR2W332MSEH
3900	63.5 × 150	13.7	0.15	3.97	LQR2W392MSEG
	76.2 × 110	14.1	0.15	3.97	LQR2W392MSEH
	90 × 90	13.6	0.15	3.97	LQR2W392MSEJ
4700	63.5 × 170	16.5	0.15	4.36	LQR2W472MSEG
	76.2 × 130	16.3	0.15	4.36	LQR2W472MSEH
	90 × 110	15.8	0.15	4.36	LQR2W472MSEJ
5600	63.5 × 190	19.4	0.15	4.76	LQR2W562MSEG
	90 × 130	19.1	0.15	4.76	LQR2W562MSEJ
6800	76.2 × 170	23.3	0.15	5.00	LQR2W682MSEH
8200	90 × 150	26.1	0.15	5.00	LQR2W822MSEJ
10000	90 × 190	31.3	0.15	5.00	LQR2W103MSEJ
12000	90 × 220	35.5	0.15	5.00	LQR2W123MSEJ

Rated ripple current (Arms) at 85°C 120Hz

### ● Frequency coefficient of rated ripple current

Frequency (Hz)	50	60	120	360	1k	10k or more
Coefficient	0.80	0.82	1.00	1.20	1.35	1.40

# ALUMINUM ELECTROLYTIC CAPACITORS



# LNY

Screw Terminal Type, 85°C Higher Capacitance

- Suited for equipment down sizing.
- Load life of 2000 hours application of ripple current at 85°C
- Compliant to the RoHS directive (2011/65/EU,(EU)2015/863).

**LNY**

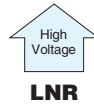

## Specifications

Item	Performance Characteristics		
Category Temperature Range	- 40 to +85°C		
Rated Voltage Range	350 to 450V		
Rated Capacitance Range	820 to 22000μF		
Capacitance Tolerance	±20% (120Hz, 20°C)		
Leakage Current	After 5 minutes' application of rated voltage, leakage current is not more than $3\sqrt{CV}$ (μA) or 5 mA, whichever is smaller. (at 20°C) [C: Rated Capacitance(μF), V: Voltage (V)]		
Tangent of loss angle (tan δ)	See refer to next page (Measurement frequency : 120Hz at 20°C)		
Stability at Low Temperature	Rated voltage(V)	350 to 450	
	Impedance ratio ZT/Z20(MAX.)	Z - 40°C / Z+20°C 12	
Measurement frequency : 120Hz			
Insulation Resistance	The insulation resistance shall be more than 100MΩ at DC 500V application between terminal and bracket.		
Voltage proof	There is no abnormality during AC 2500V 1 minute's application between terminal and bracket.		
Endurance	The specifications listed at right shall be met when the capacitors are restored to 20°C after D.C. bias plus rated ripple current is applied for 2000 hours at 85°C, the peak voltage shall not exceed the rated voltage.	Capacitance change	Within ±20% of the initial capacitance value
		tan δ	300% or less than the initial specified value
		Leakage current	Less than or equal to the initial specified value
Shelf Life	After storing the capacitors under no load at 85°C for 1000 hours and then performing voltage treatment based on JIS C 5101-4 clause 4.1 at 20°C, they shall meet the requirements listed at right.	Capacitance change	Within ±20% of the initial capacitance value
		tan δ	300% or less than the initial specified value
		Leakage current	Less than or equal to the initial specified value
Marking	Printed with white color letter on black sleeve		

## Drawing

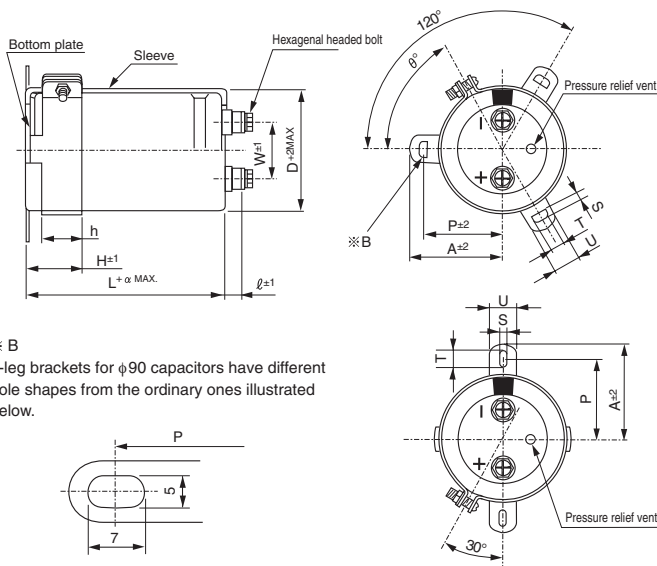

※ B  
3-leg brackets for φ90 capacitors have different hole shapes from the ordinary ones illustrated below.

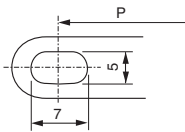

Note) The brackets will be supplied in the separate box.

## Type numbering system (Example: 400V 10000μF)

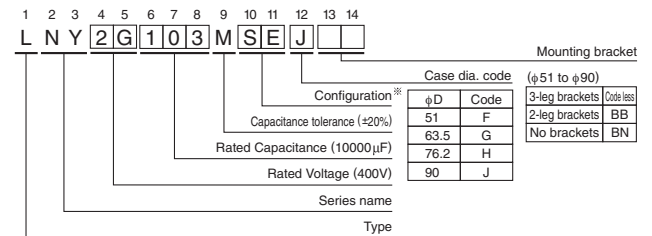

※ Configuration

Cr (III) Plating (RoHS compliant)
SE

Please refer to the Guidelines for Aluminum Electrolytic Capacitors for dimensions information.

※ Please contact to us if PVCless products are required.

● Dimension of terminal pitch (W) and length (ℓ) and Nominal dia. of bolt (mm)

φD	W	ℓ	α	Nominal dia. of bolt
51	22.0	6	3	M5
63.5	28.6	6	3	M5
76.2	31.8	6	3	M5
90	31.8	6	3	M5

● Dimension of mounting bracket (mm)

Symbol	3-Leg				2-Leg			
	51	63.5	76.2	90	51	63.5	76.2	90
P	32.5	38.1	44.5	50.8	33.2	40.5	46.5	53
A	38.5	43	49.2	58.5	40	46.5	53	59
T	7.5	8.0	7.0	8.0	6.0	7.0	6.0	6.0
S	5.0	5.0	5.0	5.0	4.5	4.5	4.5	4.5
U	12	14	14	18	14	14	14	14
θ	60	60	60	60	30	30	30	30
H	20	25	30	35	25	35	35	35
h	15	20	24	25	15	20	20	20

● Dimension table in next page.

## LN<sub>Y</sub>

### ■ Dimensions

350V (2V)					
Cap. (μF)	Size φD × L (mm)	Rated ripple (Arms)	tan δ	Leakage Current (mA)	Code
1500	51 × 60	9.3	0.25	2.17	LN <sub>Y</sub> 2V152MSEF
1800	51 × 70	10.0	0.25	2.38	LN <sub>Y</sub> 2V182MSEF
2200	51 × 80	11.1	0.25	2.63	LN <sub>Y</sub> 2V222MSEF
2700	51 × 90	12.2	0.25	2.92	LN <sub>Y</sub> 2V272MSEF
	63.5 × 65	11.9	0.25	2.92	LN <sub>Y</sub> 2V272MSEG
3300	51 × 105	13.8	0.25	3.22	LN <sub>Y</sub> 2V332MSEF
	63.5 × 75	13.1	0.25	3.22	LN <sub>Y</sub> 2V332MSEG
3900	51 × 130	14.8	0.25	3.50	LN <sub>Y</sub> 2V392MSEF
	63.5 × 80	14.1	0.25	3.50	LN <sub>Y</sub> 2V392MSEG
4700	51 × 140	15.9	0.25	3.85	LN <sub>Y</sub> 2V472MSEF
	63.5 × 90	15.8	0.25	3.85	LN <sub>Y</sub> 2V472MSEG
	76.2 × 70	15.7	0.25	3.85	LN <sub>Y</sub> 2V472MSEH
5600	63.5 × 100	17.1	0.25	4.20	LN <sub>Y</sub> 2V562MSEG
	76.2 × 85	17.0	0.25	4.20	LN <sub>Y</sub> 2V562MSEH
6800	63.5 × 125	19.2	0.25	4.63	LN <sub>Y</sub> 2V682MSEG
	76.2 × 95	18.8	0.25	4.63	LN <sub>Y</sub> 2V682MSEH
8200	63.5 × 145	20.6	0.25	5.00	LN <sub>Y</sub> 2V822MSEG
	76.2 × 105	20.2	0.25	5.00	LN <sub>Y</sub> 2V822MSEH
10000	63.5 × 165	23.2	0.25	5.00	LN <sub>Y</sub> 2V103MSEG
	76.2 × 125	23.5	0.25	5.00	LN <sub>Y</sub> 2V103MSEH
	90 × 95	23.5	0.25	5.00	LN <sub>Y</sub> 2V103MSEJ
12000	76.2 × 150	24.0	0.25	5.00	LN <sub>Y</sub> 2V123MSEH
	90 × 110	24.1	0.25	5.00	LN <sub>Y</sub> 2V123MSEJ
15000	76.2 × 190	28.0	0.25	5.00	LN <sub>Y</sub> 2V153MSEH
	90 × 140	29.2	0.25	5.00	LN <sub>Y</sub> 2V153MSEJ
18000	76.2 × 210	30.2	0.25	5.00	LN <sub>Y</sub> 2V183MSEH
	90 × 155	31.1	0.25	5.00	LN <sub>Y</sub> 2V183MSEJ
22000	90 × 190	35.4	0.25	5.00	LN <sub>Y</sub> 2V223MSEJ

400V (2G)					
Cap. (μF)	Size φD × L (mm)	Rated ripple (Arms)	tan δ	Leakage Current (mA)	Code
1000	51 × 60	6.4	0.25	1.90	LN <sub>Y</sub> 2G102MSEF
1200	51 × 65	7.1	0.25	2.08	LN <sub>Y</sub> 2G122MSEF
1500	51 × 75	8.1	0.25	2.32	LN <sub>Y</sub> 2G152MSEF
1800	51 × 85	8.7	0.25	2.55	LN <sub>Y</sub> 2G182MSEF
	63.5 × 65	9.1	0.25	2.55	LN <sub>Y</sub> 2G182MSEG
2200	51 × 95	9.6	0.25	2.81	LN <sub>Y</sub> 2G222MSEF
	63.5 × 75	10.1	0.25	2.81	LN <sub>Y</sub> 2G222MSEG
2700	51 × 115	10.5	0.25	3.12	LN <sub>Y</sub> 2G272MSEF
	63.5 × 85	11.6	0.25	3.12	LN <sub>Y</sub> 2G272MSEG
3300	51 × 145	12.4	0.25	3.45	LN <sub>Y</sub> 2G332MSEF
	63.5 × 95	13.0	0.25	3.45	LN <sub>Y</sub> 2G332MSEG
3900	51 × 170	13.8	0.25	3.75	LN <sub>Y</sub> 2G392MSEF
	63.5 × 105	14.2	0.25	3.75	LN <sub>Y</sub> 2G392MSEG
	76.2 × 85	14.6	0.25	3.75	LN <sub>Y</sub> 2G392MSEH
4700	63.5 × 125	16.1	0.25	4.11	LN <sub>Y</sub> 2G472MSEG
	76.2 × 95	16.2	0.25	4.11	LN <sub>Y</sub> 2G472MSEH
5600	63.5 × 140	16.9	0.25	4.49	LN <sub>Y</sub> 2G562MSEG
	76.2 × 105	17.6	0.25	4.49	LN <sub>Y</sub> 2G562MSEH
6800	63.5 × 165	19.1	0.25	4.95	LN <sub>Y</sub> 2G682MSEG
8200	63.5 × 210	21.2	0.25	5.00	LN <sub>Y</sub> 2G822MSEG
	76.2 × 150	21.2	0.25	5.00	LN <sub>Y</sub> 2G822MSEH
	90 × 120	21.0	0.25	5.00	LN <sub>Y</sub> 2G822MSEJ
10000	76.2 × 170	22.4	0.25	5.00	LN <sub>Y</sub> 2G103MSEH
	90 × 130	22.0	0.25	5.00	LN <sub>Y</sub> 2G103MSEJ
12000	76.2 × 220	26.0	0.25	5.00	LN <sub>Y</sub> 2G123MSEH
	90 × 155	26.0	0.25	5.00	LN <sub>Y</sub> 2G123MSEJ
15000	90 × 190	28.3	0.25	5.00	LN <sub>Y</sub> 2G153MSEJ
18000	90 × 230	30.6	0.25	5.00	LN <sub>Y</sub> 2G183MSEJ

450V (2W)					
Cap. (μF)	Size φD × L (mm)	Rated ripple (Arms)	tan δ	Leakage Current (mA)	Code
820	51 × 60	4.9	0.25	1.82	LN <sub>Y</sub> 2W821MSEF
1000	51 × 70	5.5	0.25	2.01	LN <sub>Y</sub> 2W102MSEF
1200	51 × 75	6.0	0.25	2.20	LN <sub>Y</sub> 2W122MSEF
1500	51 × 85	6.8	0.25	2.46	LN <sub>Y</sub> 2W152MSEF
	63.5 × 65	7.9	0.25	2.46	LN <sub>Y</sub> 2W152MSEG
1800	51 × 95	7.9	0.25	2.70	LN <sub>Y</sub> 2W182MSEF
	63.5 × 75	8.9	0.25	2.70	LN <sub>Y</sub> 2W182MSEG
2200	51 × 125	9.2	0.25	2.98	LN <sub>Y</sub> 2W222MSEF
	63.5 × 85	9.8	0.25	2.98	LN <sub>Y</sub> 2W222MSEG
2700	51 × 145	10.3	0.25	3.31	LN <sub>Y</sub> 2W272MSEF
	63.5 × 90	10.8	0.25	3.31	LN <sub>Y</sub> 2W272MSEG
3300	51 × 170	11.1	0.25	3.66	LN <sub>Y</sub> 2W332MSEF
	63.5 × 105	12.0	0.25	3.66	LN <sub>Y</sub> 2W332MSEG
	76.2 × 85	12.6	0.25	3.66	LN <sub>Y</sub> 2W332MSEH
3900	63.5 × 125	13.5	0.25	3.97	LN <sub>Y</sub> 2W392MSEG
	76.2 × 95	14.0	0.25	3.97	LN <sub>Y</sub> 2W392MSEH
4700	63.5 × 145	15.2	0.25	4.36	LN <sub>Y</sub> 2W472MSEG
	76.2 × 105	15.6	0.25	4.36	LN <sub>Y</sub> 2W472MSEH
5600	63.5 × 165	17.0	0.25	4.76	LN <sub>Y</sub> 2W562MSEG
	76.2 × 125	17.6	0.25	4.76	LN <sub>Y</sub> 2W562MSEH
6800	63.5 × 210	19.1	0.25	5.00	LN <sub>Y</sub> 2W682MSEG
	76.2 × 150	19.6	0.25	5.00	LN <sub>Y</sub> 2W682MSEH
	90 × 120	19.5	0.25	5.00	LN <sub>Y</sub> 2W682MSEJ
8200	76.2 × 170	20.1	0.25	5.00	LN <sub>Y</sub> 2W822MSEH
	90 × 130	20.1	0.25	5.00	LN <sub>Y</sub> 2W822MSEJ
10000	76.2 × 210	23.0	0.25	5.00	LN <sub>Y</sub> 2W103MSEH
	90 × 155	22.9	0.25	5.00	LN <sub>Y</sub> 2W103MSEJ
12000	90 × 190	26.0	0.25	5.00	LN <sub>Y</sub> 2W123MSEJ
15000	90 × 220	29.6	0.25	5.00	LN <sub>Y</sub> 2W153MSEJ

### ● Frequency coefficient of rated ripple current

Frequency (Hz)	50	60	120	360	1k	10k or more
Coefficient	0.80	0.82	1.00	1.20	1.35	1.40

Rated ripple current (Arms) at 85°C 120Hz

# ALUMINUM ELECTROLYTIC CAPACITORS

# LNT

Screw Terminal Type, 105°C Standard



- Load life of 5,000 hours (2,000 hours for 10 to 250V, 500V) application of rated ripple current at +105°C.
- Extended voltage range from 10V up to 500V.
- Extended range up to  $\phi 100 \times 250L$  2size.
- Compliant to the RoHS directive (2011/65/EU, (EU)2015/863).

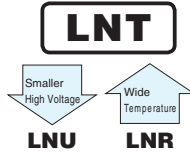

## Specifications

Item	Performance Characteristics		
Category Temperature Range	- 40 to +105°C (10 to 100V) , - 25 to +105°C (160 to 500V)		
Rated Voltage Range	10 to 500V		
Rated Capacitance Range	220 to 680000 $\mu$ F		
Capacitance Tolerance	$\pm 20\%$ at 120Hz, 20°C		
Leakage Current	After 5 minutes' application of rated voltage, leakage current is not more than $3\sqrt{C_V}$ ( $\mu$ A) or 5mA, whichever is smaller. (at 20°C) [C:Rated Capacitance ( $\mu$ F), V:Voltage(V)]		
Tangent of loss angle (tan $\delta$ ) (MAX)	See refer to next page (Measurement frequency : 120Hz at 20°C)		
Stability at Low Temperature	Rated voltage(V)		Measurement frequency : 120Hz
	Impedance ratio	10 to 100	
	Z - 25°C/Z+20°C	—	8
	ZT/Z20(MAX.)	12	—
Endurance	The specifications listed at right shall be met when the capacitors are restored to 20°C after D.C. bias plus rated ripple current is applied for 5000 hours (2000 hours for 10 to 250V/500V) at 105°C, the peak voltage shall not exceed the rated voltage.		
	Capacitance change	Within $\pm 20\%$ of the initial capacitance value	
	tan $\delta$	300% or less than the initial specified value	
Shelf Life	After storing the capacitors under no load at 105°C for 1000 hours and then performing voltage treatment based on JIS C 5101-4 clause 4.1 at 20°C, they shall meet the requirements listed at right.		
	Capacitance change	Within $\pm 20\%$ of the initial capacitance value	
	tan $\delta$	300% or less than the initial specified value	
Marking	Printed with white color letter on black sleeve.		

## Drawing

$\phi 35$  Screw terminal type

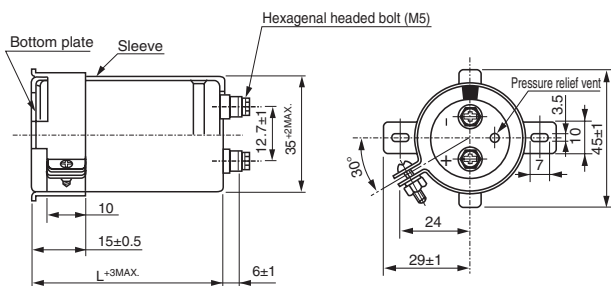

## Type numbering system

Voltage 250V or less (Example : 250V 3300 $\mu$ F)

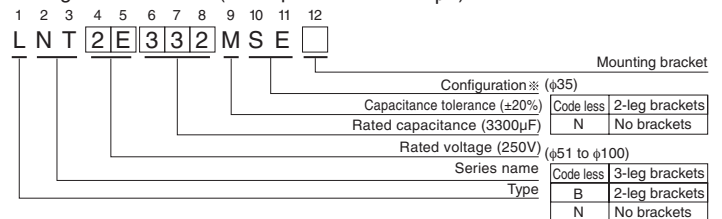

Voltage 350V or more (Example : 450V 2200 $\mu$ F)

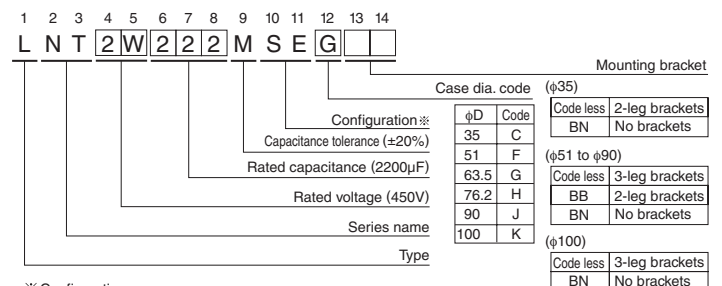

※ Configuration

Cr (III) Plating (RoHS compliant)
SE

Please refer to the Guidelines for Aluminum Electrolytic Capacitors for dimensions information.

※ Please contact to us if PVCless products are required.

● Dimension table in next page.



## LNT

Screw terminal type for  $\phi 51$  and larger

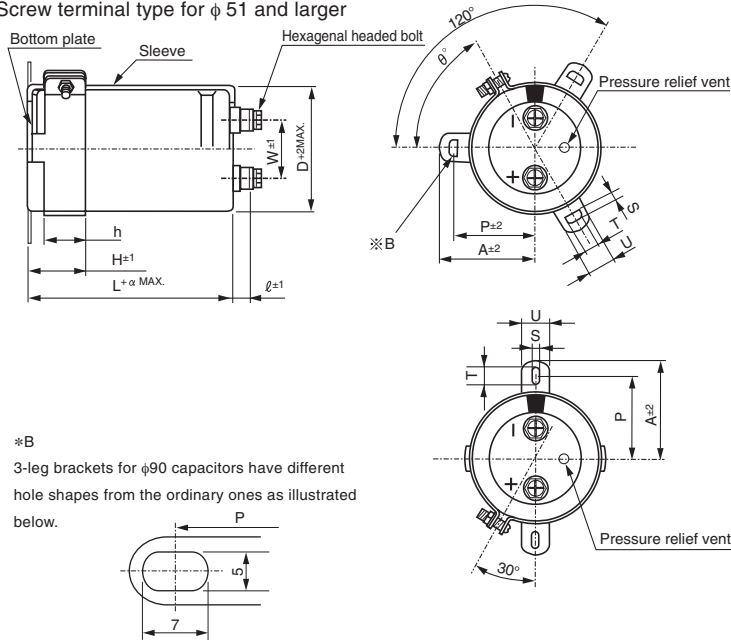

\*B  
3-leg brackets for  $\phi 90$  capacitors have different hole shapes from the ordinary ones as illustrated below.

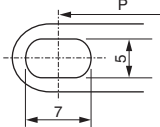

● Dimension of terminal pitch (W) and length ( $\ell$ ) and Nominal dia. of bolt (mm)

$\phi D$	W	$\ell$	$\alpha$	Nominal of bolt
51	22.0	6	3	M5
63.5	28.6	6	3	M5
76.2	31.8	6	3	M5
90	31.8	6	3	M5
100	41.5	10	4	M8

● Dimensions of mounting bracket (mm)

Symbol	Leg Shape		3-Legs					2-Legs			
	$\phi D$		51	63.5	76.2	90	100	51	63.5	76.2	90
P			32.5	38.1	44.5	50.8	56.3	33.2	40.5	46.5	53
A			38.5	43	49.2	58.5	62	40	46.5	53	59
T			7.5	8.0	7.0	8.0	8.0	6.0	7.0	6.0	6.0
S			5.0	5.0	5.0	5.0	5.0	4.5	4.5	4.5	4.5
U			12	14	14	18	16	14	14	14	14
$\theta^\circ$			60	60	60	60	60	30	30	30	30
H			20	25	30	35	36	25	35	35	35
h			15	20	24	25	30	15	20	20	20

### ■ Dimensions

10V (1A)					
Cap. ( $\mu F$ )	Size $\phi D \times L$ (mm)	Rated ripple (Arms)	$\tan \delta$	Leakage Current (mA)	Code
33000	35 × 80	4.8	0.65	1.72	LNT1A333MSE
47000	35 × 100	6.2	0.65	2.05	LNT1A473MSE
68000	51 × 80	6.8	0.80	2.47	LNT1A683MSE
100000	51 × 100	8.6	0.80	3.00	LNT1A104MSE
150000	51 × 120	10.8	0.85	3.67	LNT1A154MSE
220000	63.5 × 120	13.2	1.20	4.44	LNT1A224MSE
330000	76.2 × 120	15.8	2.00	5.00	LNT1A334MSE
470000	90 × 140	17.0	2.40	5.00	LNT1A474MSE
680000	90 × 170	18.4	2.40	5.00	LNT1A684MSE

16V (1C)					
Cap. ( $\mu F$ )	Size $\phi D \times L$ (mm)	Rated ripple (Arms)	$\tan \delta$	Leakage Current (mA)	Code
33000	35 × 80	5.2	0.45	2.17	LNT1C333MSE
47000	35 × 100	6.8	0.45	2.60	LNT1C473MSE
68000	51 × 80	7.1	0.60	3.12	LNT1C683MSE
100000	51 × 100	9.6	0.60	3.79	LNT1C104MSE
150000	51 × 120	11.0	0.60	4.64	LNT1C154MSE
220000	63.5 × 120	14.1	0.80	5.00	LNT1C224MSE
330000	76.2 × 120	20.6	1.20	5.00	LNT1C334MSE
470000	90 × 140	22.1	2.00	5.00	LNT1C474MSE
680000	90 × 170	24.0	2.00	5.00	LNT1C684MSE

Rated ripple current (Arms) at 105°C 120Hz

## LNT

### ■ Dimensions

25V (1E)					
Cap. (μF)	Size φD × L(mm)	Rated ripple (Arms)	tan δ	Leakage Current (mA)	Code
22000	35 × 80	4.9	0.40	2.22	LNT1E223MSE
33000	35 × 100	6.2	0.40	2.72	LNT1E333MSE
47000	51 × 80	8.3	0.50	3.25	LNT1E473MSE
68000	51 × 120	10.2	0.50	3.91	LNT1E683MSE
100000	63.5 × 100	11.5	0.65	4.74	LNT1E104MSE
150000	63.5 × 120	13.8	0.70	5.00	LNT1E154MSE
220000	76.2 × 120	17.0	0.90	5.00	LNT1E224MSE
330000	90 × 140	20.8	1.50	5.00	LNT1E334MSE
470000	90 × 170	22.4	1.50	5.00	LNT1E474MSE
680000	90 × 220	24.2	1.50	5.00	LNT1E684MSE

35V (1V)					
Cap. (μF)	Size φD × L(mm)	Rated ripple (Arms)	tan δ	Leakage Current (mA)	Code
10000	35 × 80	4.7	0.30	1.77	LNT1V103MSE
15000	35 × 80	5.1	0.30	2.17	LNT1V153MSE
22000	35 × 100	5.6	0.30	2.63	LNT1V223MSE
33000	51 × 80	7.4	0.40	3.22	LNT1V333MSE
47000	51 × 100	8.4	0.40	3.84	LNT1V473MSE
68000	51 × 120	12.3	0.40	4.62	LNT1V683MSE
100000	63.5 × 120	13.6	0.50	5.00	LNT1V104MSE
150000	76.2 × 120	15.1	0.70	5.00	LNT1V154MSE
220000	90 × 140	17.4	1.00	5.00	LNT1V224MSE
330000	90 × 170	21.3	1.00	5.00	LNT1V334MSE
470000	90 × 220	25.4	1.00	5.00	LNT1V474MSE
680000	100 × 250	27.5	1.00	5.00	LNT1V684MSE

50V (1H)					
Cap. (μF)	Size φD × L(mm)	Rated ripple (Arms)	tan δ	Leakage Current (mA)	Code
10000	35 × 80	4.9	0.25	2.12	LNT1H103MSE
15000	35 × 100	5.5	0.25	2.59	LNT1H153MSE
22000	51 × 80	6.3	0.25	3.14	LNT1H223MSE
33000	51 × 120	8.0	0.30	3.85	LNT1H333MSE
47000	63.5 × 100	9.9	0.35	4.59	LNT1H473MSE
68000	63.5 × 120	12.8	0.35	5.00	LNT1H683MSE
100000	76.2 × 120	16.8	0.55	5.00	LNT1H104MSE
150000	90 × 140	19.5	0.75	5.00	LNT1H154MSE
220000	90 × 170	22.0	0.75	5.00	LNT1H224MSE
330000	90 × 220	24.3	0.75	5.00	LNT1H334MSE
470000	100 × 250	26.1	0.75	5.00	LNT1H474MSE

63V (1J)					
Cap. (μF)	Size φD × L(mm)	Rated ripple (Arms)	tan δ	Leakage Current (mA)	Code
10000	35 × 100	5.0	0.25	2.38	LNT1J103MSE
15000	51 × 80	5.9	0.25	2.91	LNT1J153MSE
22000	51 × 100	6.9	0.25	3.53	LNT1J223MSE
33000	63.5 × 100	9.4	0.30	4.32	LNT1J333MSE
47000	63.5 × 120	11.2	0.30	5.00	LNT1J473MSE
68000	76.2 × 120	13.5	0.50	5.00	LNT1J683MSE
100000	90 × 140	17.8	0.60	5.00	LNT1J104MSE
150000	90 × 170	21.0	0.60	5.00	LNT1J154MSE
220000	90 × 220	23.7	0.60	5.00	LNT1J224MSE
330000	100 × 250	26.1	0.60	5.00	LNT1J334MSE

80V (1K)					
Cap. (μF)	Size φD × L(mm)	Rated ripple (Arms)	tan δ	Leakage Current (mA)	Code
4700	35 × 80	3.5	0.20	1.83	LNT1K472MSE
6800	35 × 100	3.9	0.20	2.21	LNT1K682MSE
10000	51 × 80	5.4	0.20	2.68	LNT1K103MSE
15000	51 × 100	6.4	0.20	3.28	LNT1K153MSE
22000	63.5 × 100	8.4	0.25	3.97	LNT1K223MSE
33000	76.2 × 100	9.9	0.30	4.87	LNT1K333MSE
47000	76.2 × 120	13.4	0.35	5.00	LNT1K473MSE
68000	90 × 140	17.0	0.40	5.00	LNT1K683MSE
100000	90 × 170	18.6	0.40	5.00	LNT1K104MSE
150000	90 × 220	21.6	0.40	5.00	LNT1K154MSE
220000	100 × 250	24.8	0.40	5.00	LNT1K224MSE

100V (2A)					
Cap. (μF)	Size φD × L(mm)	Rated ripple (Arms)	tan δ	Leakage Current (mA)	Code
2200	35 × 80	2.4	0.12	1.40	LNT2A222MSE
3300	35 × 80	3.3	0.12	1.72	LNT2A332MSE
4700	35 × 100	3.8	0.12	2.05	LNT2A472MSE
6800	51 × 80	5.2	0.15	2.47	LNT2A682MSE
10000	51 × 100	6.7	0.15	3.00	LNT2A103MSE
15000	63.5 × 100	7.8	0.20	3.67	LNT2A153MSE
22000	76.2 × 100	9.9	0.30	4.44	LNT2A223MSE
33000	76.2 × 140	12.7	0.30	5.00	LNT2A333MSE
47000	90 × 140	17.0	0.30	5.00	LNT2A473MSE
68000	90 × 170	18.2	0.30	5.00	LNT2A683MSE
100000	90 × 220	20.6	0.30	5.00	LNT2A104MSE
150000	100 × 220	23.4	0.30	5.00	LNT2A154MSE

Rated ripple current (Arms) at 105°C 120Hz

## LNT

### ■ Dimensions

160V (2C)					
Cap. (μF)	Size φD × L(mm)	Rated ripple (Arms)	tan δ	Leakage Current (mA)	Code
1000	35 × 80	1.6	0.15	1.20	LNT2C102MSE
1500	35 × 80	2.1	0.15	1.46	LNT2C152MSE
2200	35 × 100	2.7	0.15	1.77	LNT2C222MSE
3300	51 × 80	3.8	0.15	2.17	LNT2C332MSE
4700	51 × 100	4.5	0.15	2.60	LNT2C472MSE
6800	63.5 × 100	6.8	0.20	3.12	LNT2C682MSE
10000	63.5 × 120	7.8	0.20	3.79	LNT2C103MSE
15000	76.2 × 120	9.8	0.20	4.64	LNT2C153MSE
22000	76.2 × 140	12.5	0.20	5.00	LNT2C223MSE
33000	90 × 140	13.4	0.25	5.00	LNT2C333MSE
47000	90 × 220	17.2	0.25	5.00	LNT2C473MSE
68000	100 × 250	19.2	0.25	5.00	LNT2C683MSE

200V (2D)					
Cap. (μF)	Size φD × L(mm)	Rated ripple (Arms)	tan δ	Leakage Current (mA)	Code
1000	35 × 80	1.7	0.15	1.34	LNT2D102MSE
1500	35 × 100	2.3	0.15	1.64	LNT2D152MSE
2200	51 × 80	2.9	0.15	1.99	LNT2D222MSE
3300	51 × 100	3.9	0.15	2.43	LNT2D332MSE
4700	63.5 × 100	5.1	0.20	2.90	LNT2D472MSE
6800	63.5 × 120	7.0	0.20	3.49	LNT2D682MSE
10000	76.2 × 120	8.2	0.20	4.24	LNT2D103MSE
15000	76.2 × 140	10.4	0.20	5.00	LNT2D153MSE
22000	90 × 140	15.1	0.25	5.00	LNT2D223MSE
33000	90 × 220	16.6	0.25	5.00	LNT2D333MSE
47000	90 × 250	19.9	0.25	5.00	LNT2D473MSE

250V (2E)					
Cap. (μF)	Size φD × L(mm)	Rated ripple (Arms)	tan δ	Leakage Current (mA)	Code
680	35 × 80	1.4	0.15	1.23	LNT2E681MSE
1000	35 × 100	1.9	0.15	1.50	LNT2E102MSE
1500	51 × 80	2.4	0.15	1.83	LNT2E152MSE
2200	51 × 100	3.2	0.15	2.22	LNT2E222MSE
3300	63.5 × 100	4.3	0.20	2.72	LNT2E332MSE
4700	63.5 × 120	5.9	0.20	3.25	LNT2E472MSE
6800	76.2 × 120	7.1	0.20	3.91	LNT2E682MSE
10000	90 × 140	9.6	0.25	4.74	LNT2E103MSE
15000	90 × 170	12.7	0.25	5.00	LNT2E153MSE
22000	90 × 220	15.4	0.25	5.00	LNT2E223MSE
33000	100 × 250	17.0	0.25	5.00	LNT2E333MSE

350V (2V)					
Cap. (μF)	Size φD × L(mm)	Rated ripple (Arms)	tan δ	Leakage Current (mA)	Code
330	35 × 80	2.1	0.20	1.01	LNT2V331MSEC
470	35 × 80	2.8	0.20	1.21	LNT2V471MSEC
680	51 × 80	4.1	0.20	1.46	LNT2V681MSEF
1000	51 × 80	6.5	0.20	1.77	LNT2V102MSEF
1500	51 × 100	8.6	0.20	2.17	LNT2V152MSEF
2200	51 × 120	11.0	0.20	2.63	LNT2V222MSEF
2700	63.5 × 100	12.7	0.20	2.91	LNT2V272MSEG
3300	63.5 × 110	14.4	0.20	3.22	LNT2V332MSEG
3900	63.5 × 130	16.8	0.20	3.50	LNT2V392MSEG
4700	63.5 × 150	19.8	0.20	3.84	LNT2V472MSEG
	76.2 × 120	19.7	0.20	3.84	LNT2V472MSEH
5600	63.5 × 170	22.7	0.20	4.20	LNT2V562MSEG
	76.2 × 130	22.2	0.20	4.20	LNT2V562MSEH
6800	76.2 × 150	26.2	0.20	4.62	LNT2V682MSEH
8200	76.2 × 170	30.3	0.20	5.00	LNT2V822MSEH
	90 × 150	29.3	0.20	5.00	LNT2V822MSEJ
10000	90 × 150	32.4	0.20	5.00	LNT2V103MSEJ
12000	90 × 190	36.0	0.20	5.00	LNT2V123MSEJ
15000	90 × 220	42.9	0.20	5.00	LNT2V153MSEJ
22000	100 × 250	48.0	0.20	5.00	LNT2V223MSEK

Rated ripple current (Arms) at 105°C 120Hz

## LNT

### ■ Dimensions

400V (2G)					
Cap. (μF)	Size φD × L(mm)	Rated ripple (Arms)	tan δ	Leakage Current (mA)	Code
220	35 × 80	1.6	0.20	0.88	LNT2G221MSEC
330	35 × 80	2.3	0.20	1.09	LNT2G331MSEC
470	35 × 100	3.1	0.20	1.30	LNT2G471MSEC
680	51 × 80	4.2	0.20	1.56	LNT2G681MSEF
1000	51 × 80	6.6	0.20	1.89	LNT2G102MSEF
1500	51 × 120	9.1	0.20	2.32	LNT2G152MSEF
2200	63.5 × 100	11.5	0.20	2.81	LNT2G222MSEG
2700	63.5 × 110	13.1	0.20	3.11	LNT2G272MSEG
3300	63.5 × 130	15.4	0.20	3.44	LNT2G332MSEG
3900	63.5 × 150	17.9	0.20	3.74	LNT2G392MSEG
	76.2 × 110	18.2	0.20	3.74	LNT2G392MSEH
4700	63.5 × 170	20.7	0.20	4.11	LNT2G472MSEG
	76.2 × 130	20.3	0.20	4.11	LNT2G472MSEH
5600	76.2 × 150	23.7	0.20	4.49	LNT2G562MSEH
6800	76.2 × 170	27.6	0.20	4.94	LNT2G682MSEH
	90 × 150	26.9	0.20	4.94	LNT2G682MSEJ
8200	90 × 170	31.0	0.20	5.00	LNT2G822MSEJ
10000	90 × 190	32.9	0.20	5.00	LNT2G103MSEJ
12000	90 × 220	38.3	0.20	5.00	LNT2G123MSEJ
15000	100 × 220	44.5	0.20	5.00	LNT2G153MSEK

450V (2W)					
Cap. (μF)	Size φD × L(mm)	Rated ripple (Arms)	tan δ	Leakage Current (mA)	Code
220	35 × 80	1.8	0.20	0.94	LNT2W221MSEC
330	35 × 100	2.4	0.20	1.15	LNT2W331MSEC
470	51 × 80	3.4	0.20	1.37	LNT2W471MSEF
680	51 × 100	4.4	0.20	1.65	LNT2W681MSEF
1000	51 × 100	7.0	0.20	2.01	LNT2W102MSEF
1500	51 × 120	9.2	0.20	2.46	LNT2W152MSEF
2200	63.5 × 110	11.8	0.20	2.98	LNT2W222MSEG
2700	63.5 × 130	13.8	0.20	3.30	LNT2W272MSEG
	76.2 × 110	14.5	0.20	3.30	LNT2W272MSEH
3300	63.5 × 150	16.5	0.20	3.65	LNT2W332MSEG
	76.2 × 130	17.1	0.20	3.65	LNT2W332MSEH
3900	63.5 × 170	18.3	0.20	3.97	LNT2W392MSEG
4700	76.2 × 150	21.7	0.20	4.36	LNT2W472MSEH
5600	76.2 × 190	26.4	0.20	4.76	LNT2W562MSEH
	90 × 150	24.1	0.20	4.76	LNT2W562MSEJ
6800	90 × 170	28.3	0.20	5.00	LNT2W682MSEJ
8200	90 × 190	32.5	0.20	5.00	LNT2W822MSEJ
10000	90 × 220	35.1	0.20	5.00	LNT2W103MSEJ
12000	90 × 230	39.2	0.20	5.00	LNT2W123MSEJ
15000	90 × 250	45.6	0.20	5.00	LNT2W153MSEJ

500V (2H)					
Cap. (μF)	Size φD × L(mm)	Rated ripple (Arms)	tan δ	Leakage Current (mA)	Code
330	51 × 80	2.7	0.20	1.21	LNT2H331MSEF
470	51 × 80	3.2	0.20	1.45	LNT2H471MSEF
680	51 × 100	4.2	0.20	1.74	LNT2H681MSEF
1000	51 × 120	5.5	0.20	2.12	LNT2H102MSEF
1500	63.5 × 110	7.1	0.20	2.59	LNT2H152MSEG
2200	63.5 × 130	9.3	0.20	3.14	LNT2H222MSEG
2700	63.5 × 150	11.0	0.20	3.48	LNT2H272MSEG
	76.2 × 130	11.0	0.20	3.48	LNT2H272MSEH
3300	63.5 × 170	12.9	0.20	3.85	LNT2H332MSEG
	76.2 × 150	13.0	0.20	3.85	LNT2H332MSEH
3900	76.2 × 150	14.1	0.20	4.18	LNT2H392MSEH
4700	76.2 × 190	17.2	0.20	4.59	LNT2H472MSEH
	90 × 150	16.3	0.20	4.59	LNT2H472MSEJ
5600	90 × 150	17.8	0.20	5.00	LNT2H562MSEJ
6800	90 × 170	20.7	0.20	5.00	LNT2H682MSEJ
8200	90 × 220	25.5	0.20	5.00	LNT2H822MSEJ
10000	90 × 250	29.9	0.20	5.00	LNT2H103MSEJ

Rated ripple current (Arms) at 105°C 120Hz

### ● Frequency coefficient of rated ripple current

Coeff.	Frequency (Hz)					
	10 to 100V	60	120	360	1k	10k or more
	160 to 250V	0.90	1.00	1.08	1.15	1.15
350 to 500V	0.88	1.00	1.08	1.15	1.20	
	0.82	1.00	1.20	1.35	1.40	

# ALUMINUM ELECTROLYTIC CAPACITORS

# LNU

Screw Terminal Type, 105°C  
High Voltage, Smaller Sized.

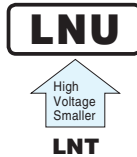

- Suited for use in industrial power supplies for inverter circuitry, etc.
- Rated voltage range up to DC525V.
- Load life of 5000 hours application of ripple current at 105°C.
- High voltage / Smaller sized than LNT.
- Coped with loading of high speed charge-discharge.
- Suited for high frequency regenerative voltage for AC servomotor, general inverter.
- Compliant to the RoHS directive (2011/65/EU,(EU)2015/863).

## Specifications

Item	Performance Characteristics	
Category Temperature Range	- 40 to +105°C	
Rated Voltage Range	400 to 525V	
Rated Capacitance Range	680 to 18000μF	
Capacitance Tolerance	±20% (120Hz, 20°C)	
Leakage Current	After 5 minutes' application of rated voltage, leakage current is not more than $3\sqrt{CV}$ (μA) or 5 mA, whichever is smaller. (at 20°C) [C: Rated Capacitance(μF), V: Voltage (V)]	
Tangent of loss angle (tan δ)	See refer to next page (Measurement frequency : 120Hz at 20°C)	
Stability at Low Temperature	Rated voltage(V)	400 to 525
	Impedance ratio ZT/Z20(MAX.)	Z - 40°C / Z +20°C 8
Measurement frequency : 120Hz		
Insulation Resistance	The insulation resistance shall be more than 100MΩ at DC 500V application between terminal and bracket.	
Voltage proof	There is no abnormality during AC 2500V 1 minute's application between terminal and bracket.	
Endurance	Capacitance change	Within ±20% of the initial capacitance value
	tan δ	200% or less than the initial specified value
	Leakage current	Less than or equal to the initial specified value
Shelf Life	Capacitance change	Within ±20% of the initial capacitance value
	tan δ	200% or less than the initial specified value
	Leakage current	Less than or equal to the initial specified value
Endurance of charge - discharge behavior	Capacitance change	Within ±20% of the initial capacitance value
	tan δ	200% or less than the initial specified value
	Leakage current	Less than or equal to the initial specified value
Marking	Printed with white color letter on black sleeve	

## Drawing

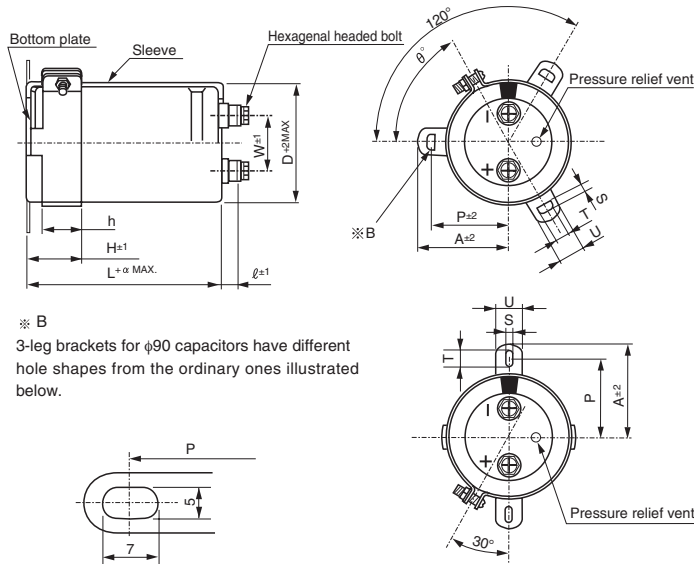

Note) The brackets will be supplied in the separate box.

### Dimension of terminal pitch (W) and length (ℓ) and Nominal dia. of bolt (mm)

φD	W	ℓ	α	Nominal dia. of bolt
51	22.0	6	3	M5
63.5	28.6	6	3	M5
76.2	31.8	6	3	M5
90	31.8	6	3	M5

About product of stud bolt  
 • Nylon nut and nylon washer attachment are shown in the standard specifications. (Please refer to the Guidelines for Aluminum Electrolytic Capacitors)  
 • It is not attached to the bracket.  
 • Field 13 and 14 become blank in Type number system.

## Type numbering system (Example : 500V 4700μF)

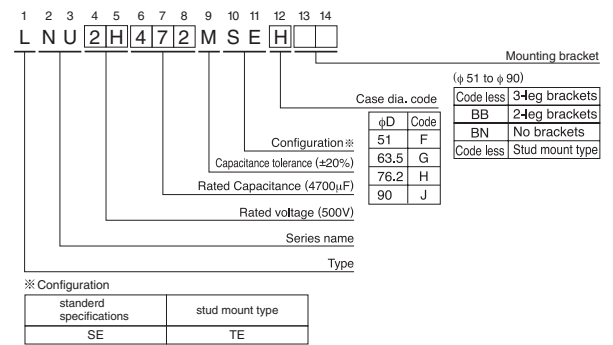

Please refer to the Guidelines for Aluminum Electrolytic Capacitors for dimensions information.

※ Please contact to us if PVCless products are required.

### Dimensions of mounting bracket (mm)

Leg shape	φD	3-Leg				2-Leg			
		51	63.5	76.2	90	51	63.5	76.2	90
P		32.5	38.1	44.5	50.8	33.2	40.5	46.5	53
A		38.5	43	49.2	58.5	40	46.5	53	59
T		7.5	8.0	7.0	8.0	6.0	7.0	6.0	6.0
S		5.0	5.0	5.0	5.0	4.5	4.5	4.5	4.5
U		12	14	14	18	14	14	14	14
θ°		60	60	60	60	30	30	30	30
H		20	25	30	35	25	35	35	35
h		15	20	24	25	15	20	20	20

• Dimension table in next page.

## LNU

### ■ Dimensions

400V (2G)					
Cap. (μF)	Size φD × L(mm)	Rated ripple (Arms)	tan δ	Leakage Current (mA)	Code
2700	63.5 × 80	11.9	0.20	3.12	LNU2G272MSEG
3300	63.5 × 95	13.6	0.20	3.45	LNU2G332MSEG
	76.2 × 75	13.1	0.20	3.45	LNU2G332MSEH
3900	63.5 × 100	14.6	0.20	3.75	LNU2G392MSEG
	76.2 × 85	14.3	0.20	3.75	LNU2G392MSEH
4700	63.5 × 120	16.1	0.20	4.11	LNU2G472MSEG
	76.2 × 95	15.8	0.20	4.11	LNU2G472MSEH
5600	63.5 × 135	17.7	0.20	4.49	LNU2G562MSEG
	76.2 × 105	17.1	0.20	4.49	LNU2G562MSEH
6800	76.2 × 125	19.5	0.20	4.95	LNU2G682MSEH
	90 × 105	18.8	0.20	4.95	LNU2G682MSEJ
8200	76.2 × 170	24.2	0.20	5.00	LNU2G822MSEH
	90 × 125	23.1	0.20	5.00	LNU2G822MSEJ
10000	90 × 145	25.9	0.20	5.00	LNU2G103MSEJ
12000	90 × 165	30.1	0.20	5.00	LNU2G123MSEJ
15000	90 × 195	33.5	0.20	5.00	LNU2G153MSEJ
18000	90 × 235	38.0	0.20	5.00	LNU2G183MSEJ

450V (2W)					
Cap. (μF)	Size φD × L(mm)	Rated ripple (Arms)	tan δ	Leakage Current (mA)	Code
2700	63.5 × 100	13.1	0.20	3.31	LNU2W272MSEG
3300	63.5 × 120	15.0	0.20	3.66	LNU2W332MSEG
	76.2 × 95	14.4	0.20	3.66	LNU2W332MSEH
3900	63.5 × 135	16.3	0.20	3.97	LNU2W392MSEG
	76.2 × 105	15.4	0.20	3.97	LNU2W392MSEH
4700	63.5 × 165	18.5	0.20	4.36	LNU2W472MSEG
	76.2 × 130	17.9	0.20	4.36	LNU2W472MSEH
5600	76.2 × 150	20.5	0.20	4.76	LNU2W562MSEH
	90 × 105	19.6	0.20	4.76	LNU2W562MSEJ
6800	76.2 × 170	23.4	0.20	5.00	LNU2W682MSEH
	90 × 125	22.5	0.20	5.00	LNU2W682MSEJ
8200	76.2 × 195	25.7	0.20	5.00	LNU2W822MSEH
	90 × 145	24.7	0.20	5.00	LNU2W822MSEJ
10000	90 × 165	27.3	0.20	5.00	LNU2W103MSEJ
12000	90 × 195	29.9	0.20	5.00	LNU2W123MSEJ
15000	90 × 235	34.5	0.20	5.00	LNU2W153MSEJ

500V (2H)					
Cap. (μF)	Size φD × L(mm)	Rated ripple (Arms)	tan δ	Leakage Current (mA)	Code
680	51 × 75	4.0	0.20	1.75	LNU2H681MSEF
1000	51 × 90	5.0	0.20	2.12	LNU2H102MSEF
1200	51 × 115	5.7	0.20	2.32	LNU2H122MSEF
	63.5 × 80	5.7	0.20	2.32	LNU2H122MSEG
1500	51 × 135	6.6	0.20	2.60	LNU2H152MSEF
	63.5 × 90	6.6	0.20	2.60	LNU2H152MSEG
1800	63.5 × 100	7.4	0.20	2.85	LNU2H182MSEG
	76.2 × 70	7.4	0.20	2.85	LNU2H182MSEH
2200	63.5 × 120	8.5	0.20	3.15	LNU2H222MSEG
	76.2 × 95	8.5	0.20	3.15	LNU2H222MSEH
2700	63.5 × 135	9.6	0.20	3.49	LNU2H272MSEG
	76.2 × 105	9.6	0.20	3.49	LNU2H272MSEH
3300	63.5 × 165	10.9	0.20	3.85	LNU2H332MSEG
	76.2 × 130	10.9	0.20	3.85	LNU2H332MSEH
3900	76.2 × 145	12.4	0.20	4.19	LNU2H392MSEH
	90 × 105	12.4	0.20	4.19	LNU2H392MSEJ
4700	76.2 × 165	13.9	0.20	4.60	LNU2H472MSEH
	90 × 125	13.9	0.20	4.60	LNU2H472MSEJ
5600	90 × 145	15.8	0.20	5.00	LNU2H562MSEJ
6800	90 × 165	18.5	0.20	5.00	LNU2H682MSEJ
8200	90 × 205	20.2	0.20	5.00	LNU2H822MSEJ

525V (N7)					
Cap. (μF)	Size φD × L(mm)	Rated ripple (Arms)	tan δ	Leakage Current (mA)	Code
680	51 × 85	4.4	0.20	1.75	LNUN7681MSEF
1000	51 × 95	5.4	0.20	2.12	LNUN7102MSEF
1500	63.5 × 95	7.2	0.20	2.60	LNUN7152MSEG
1800	63.5 × 105	8.0	0.20	2.85	LNUN7182MSEG
2200	63.5 × 135	9.2	0.20	3.15	LNUN7222MSEG
	76.2 × 100	9.2	0.20	3.15	LNUN7222MSEH
2700	76.2 × 115	10.6	0.20	3.49	LNUN7272MSEH
3300	76.2 × 140	12.1	0.20	3.85	LNUN7332MSEH
4700	76.2 × 185	15.2	0.20	4.60	LNUN7472MSEH
	90 × 135	15.2	0.20	4.60	LNUN7472MSEJ
5600	90 × 155	17.5	0.20	5.00	LNUN7562MSEJ

Rated ripple current (Arms) at 105°C 120Hz

### ● Frequency coefficient of rated ripple current

Frequency (Hz)	50	60	120	360	1k	10k or more
Coefficient	0.80	0.82	1.00	1.20	1.30	1.40

# ALUMINUM ELECTROLYTIC CAPACITORS

# LKG

Lug / Snap-in Terminal Type,  
For Audio Equipment



- Designed for high grade audio equipment, giving priority to high fidelity sound quality.
- The variation expansion of the LKG.
- TYPE- I : The low profile high tone quality grade of the new development electrolyte adoption.
- TYPE- II : The center grade that the best sound is provided electrode foil, with the multiple use.
- TYPE- III : The highest tone quality grade by the low drag the gold plating terminal adoption.
- The sound quality that it meets the high tone quality needs for HD Audio equipment.
- Compliant to the RoHS directive (2011/65/EU,(EU)2015/863).

Super Through  
High Grade  
Gold Tune



## Specifications

Item	Performance Characteristics								
Category Temperature Range	- 40 to +85°C								
Rated Voltage Range	16 to 100V (TYPE- I , TYPE- II , TYPE-III)								
Rated Capacitance Range	680 to 33000μF								
Capacitance Tolerance	±20% at 120Hz, 20°C								
Leakage Current	After 5 minutes' application of rated voltage at 20°C, leakage current is not more than $3\sqrt{CV}$ (μA), [C: Rated Capacitance(μF), V: Voltage (V)]								
Tangent of loss angle (tan δ)	See refer to next page (Measurement frequency : 120Hz at 20°C)								
Stability at Low Temperature	<table border="1"> <thead> <tr> <th>Rated voltage(V)</th> <th>16 to 100</th> <th>Measurement frequency : 120Hz</th> </tr> </thead> <tbody> <tr> <td rowspan="2">Impedance ratio ZT/Z20(MAX.)</td> <td>Z - 25°C/Z+20°C</td> <td>4</td> </tr> <tr> <td>Z - 40°C/Z+20°C</td> <td>12</td> </tr> </tbody> </table>	Rated voltage(V)	16 to 100	Measurement frequency : 120Hz	Impedance ratio ZT/Z20(MAX.)	Z - 25°C/Z+20°C	4	Z - 40°C/Z+20°C	12
	Rated voltage(V)	16 to 100	Measurement frequency : 120Hz						
Impedance ratio ZT/Z20(MAX.)	Z - 25°C/Z+20°C	4							
	Z - 40°C/Z+20°C	12							
Endurance	The specifications listed at right shall be met when the capacitors are restored to 20°C after the rated voltage is applied for 1000 hours at 85°C.								
	<table border="1"> <tbody> <tr> <td>Capacitance change</td> <td>Within ±20% of the initial capacitance value</td> </tr> <tr> <td>tan δ</td> <td>200% or less than the initial specified value</td> </tr> <tr> <td>Leakage current</td> <td>Less than or equal to the initial specified value</td> </tr> </tbody> </table>	Capacitance change	Within ±20% of the initial capacitance value	tan δ	200% or less than the initial specified value	Leakage current	Less than or equal to the initial specified value		
	Capacitance change	Within ±20% of the initial capacitance value							
tan δ	200% or less than the initial specified value								
Leakage current	Less than or equal to the initial specified value								
Shelf Life	After storing the capacitors under no load at 85°C for 1000 hours and then performing voltage treatment based on JIS C 5101-4 clause 4.1 at 20°C, they shall meet the specified values for the endurance characteristics listed above.								
Marking	Printed with gold color letter on black sleeve.								

## Type numbering system (Snap-in terminal type)

(Example : Gold Tune 25 V 6800μF, Dia.φ30)

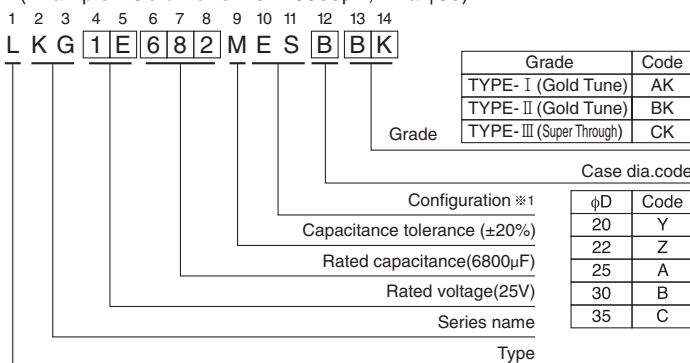

※1 Configuration

Pb-free terminal  
Pb-free PET sleeve  
ES

(Snap-in terminal type)

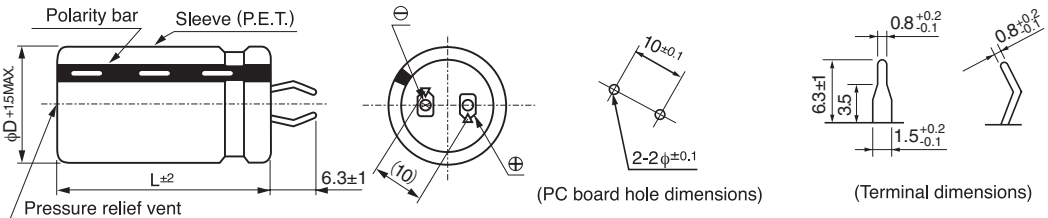

(Lug terminal type)

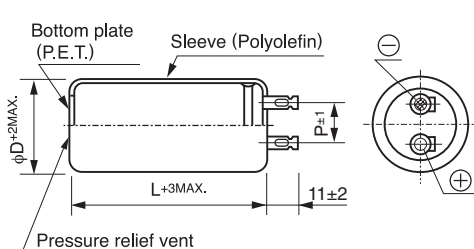

## Configuration ※2

φ35 to φ40 φ50 to φ76

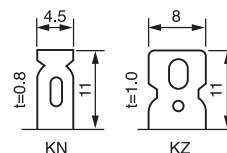

	(mm)				
φD	35	40	50	63	76
P	14	14	18	25	25
Configuration	KN		KZ		

● Dimension table in next page.



■ Dimensions (Snap-in Terminal Type : Grade TYPE- I )

16V(1C)				
Cap. (μF)	Size φD × L(mm)	Rated ripple (Arms)	tan δ	Code
4700	22 × 20	1.35	0.35	LKG1C472MESZAK
5600	20 × 25	1.45	0.35	LKG1C562MESYAK
6800	25 × 20	1.70	0.35	LKG1C682MESAAK
8200	20 × 30	1.90	0.35	LKG1C822MESYAK
	22 × 25	1.90	0.35	LKG1C822MESZAK
10000	20 × 35	2.05	0.35	LKG1C103MESYAK
	22 × 30	2.05	0.35	LKG1C103MESZAK
	25 × 25	2.00	0.35	LKG1C103MESAAK
	30 × 20	2.10	0.35	LKG1C103MESBAK
12000	20 × 40	2.25	0.35	LKG1C123MESYAK
	22 × 35	2.20	0.35	LKG1C123MESZAK
	25 × 30	2.15	0.35	LKG1C123MESAAK
	35 × 20	2.10	0.35	LKG1C123MESCAK
15000	20 × 45	2.60	0.35	LKG1C153MESYAK
	22 × 40	2.50	0.35	LKG1C153MESZAK
	25 × 35	2.40	0.35	LKG1C153MESAAK
	30 × 25	2.50	0.35	LKG1C153MESBAK
18000	22 × 45	2.80	0.35	LKG1C183MESZAK
	25 × 40	2.60	0.35	LKG1C183MESAAK
	30 × 30	2.65	0.35	LKG1C183MESBAK
22000	25 × 45	2.95	0.35	LKG1C223MESAAK
	30 × 35	2.90	0.35	LKG1C223MESBAK
	35 × 25	2.90	0.35	LKG1C223MESCAK
27000	25 × 50	3.40	0.45	LKG1C273MESAAK
	30 × 40	3.25	0.45	LKG1C273MESBAK
	35 × 30	3.35	0.45	LKG1C273MESCAK
33000	30 × 45	3.70	0.57	LKG1C333MESBAK
	35 × 35	3.65	0.57	LKG1C333MESCAK

35V(1V)				
Cap. (μF)	Size φD × L(mm)	Rated ripple (Arms)	tan δ	Code
2200	22 × 20	1.45	0.30	LKG1V222MESZAK
2700	20 × 25	1.60	0.30	LKG1V272MESYAK
	25 × 20	1.55	0.30	LKG1V272MESAAK
3300	20 × 30	1.75	0.30	LKG1V332MESYAK
	22 × 25	1.75	0.30	LKG1V332MESZAK
3900	30 × 20	1.85	0.30	LKG1V392MESBAK
4700	20 × 35	2.20	0.30	LKG1V472MESYAK
	22 × 30	2.20	0.30	LKG1V472MESZAK
	25 × 25	2.15	0.30	LKG1V472MESAAK
5600	20 × 40	2.40	0.30	LKG1V562MESYAK
	22 × 35	2.35	0.30	LKG1V562MESZAK
	25 × 30	2.25	0.30	LKG1V562MESAAK
	35 × 20	2.25	0.30	LKG1V562MESCAK
6800	20 × 50	2.50	0.30	LKG1V682MESYAK
	22 × 40	2.60	0.30	LKG1V682MESZAK
8200	30 × 25	2.60	0.30	LKG1V682MESBAK
	22 × 45	2.90	0.30	LKG1V822MESZAK
	25 × 40	2.70	0.30	LKG1V822MESAAK
10000	30 × 30	2.75	0.30	LKG1V822MESBAK
	25 × 45	3.05	0.30	LKG1V103MESAAK
	30 × 35	3.00	0.30	LKG1V103MESBAK
12000	35 × 25	3.20	0.30	LKG1V103MESCAK
	25 × 50	3.45	0.30	LKG1V123MESAAK
	30 × 40	3.30	0.30	LKG1V123MESBAK
	35 × 30	3.40	0.30	LKG1V123MESCAK
15000	30 × 45	3.80	0.30	LKG1V153MESBAK
	35 × 35	3.80	0.30	LKG1V153MESCAK
18000	30 × 50	4.30	0.30	LKG1V183MESBAK
	35 × 40	4.15	0.30	LKG1V183MESCAK
22000	35 × 45	4.70	0.30	LKG1V223MESCAK

25V(1E)				
Cap. (μF)	Size φD × L(mm)	Rated ripple (Arms)	tan δ	Code
3300	22 × 20	1.50	0.30	LKG1E332MESZAK
3900	20 × 25	1.60	0.30	LKG1E392MESYAK
	25 × 20	1.55	0.30	LKG1E392MESAAK
4700	20 × 30	1.70	0.30	LKG1E472MESYAK
	22 × 25	1.70	0.30	LKG1E472MESZAK
5600	30 × 20	1.85	0.30	LKG1E562MESBAK
6800	20 × 35	2.20	0.30	LKG1E682MESYAK
	22 × 30	2.20	0.30	LKG1E682MESZAK
	25 × 25	2.15	0.30	LKG1E682MESAAK
8200	20 × 40	2.40	0.30	LKG1E822MESYAK
	22 × 35	2.35	0.30	LKG1E822MESZAK
	25 × 30	2.30	0.30	LKG1E822MESAAK
	35 × 20	2.25	0.30	LKG1E822MESCAK
10000	20 × 50	2.55	0.30	LKG1E103MESYAK
	22 × 40	2.65	0.30	LKG1E103MESZAK
	25 × 35	2.50	0.30	LKG1E103MESAAK
	30 × 25	2.65	0.30	LKG1E103MESBAK
12000	22 × 45	2.90	0.30	LKG1E123MESZAK
	25 × 40	2.75	0.30	LKG1E123MESAAK
	30 × 30	2.80	0.30	LKG1E123MESBAK
	35 × 25	2.65	0.30	LKG1E123MESCAK
15000	25 × 45	3.15	0.30	LKG1E153MESAAK
	30 × 35	3.10	0.30	LKG1E153MESBAK
18000	25 × 50	3.55	0.30	LKG1E183MESAAK
	30 × 40	3.40	0.30	LKG1E183MESBAK
	35 × 30	3.50	0.30	LKG1E183MESCAK
22000	30 × 45	3.85	0.30	LKG1E223MESBAK
	35 × 35	3.85	0.30	LKG1E223MESCAK
27000	35 × 40	4.30	0.40	LKG1E273MESCAK
33000	35 × 45	4.85	0.52	LKG1E333MESCAK

50V(1H)				
Cap. (μF)	Size φD × L(mm)	Rated ripple (Arms)	tan δ	Code
1500	22 × 20	1.55	0.30	LKG1H152MESZAK
1800	20 × 25	1.70	0.30	LKG1H182MESYAK
	25 × 20	1.65	0.30	LKG1H182MESAAK
2200	20 × 30	1.85	0.30	LKG1H222MESYAK
	22 × 25	1.85	0.30	LKG1H222MESZAK
2700	20 × 35	2.00	0.30	LKG1H272MESYAK
	22 × 30	2.00	0.30	LKG1H272MESZAK
	25 × 25	1.95	0.30	LKG1H272MESAAK
	30 × 20	2.05	0.30	LKG1H272MESBAK
3300	20 × 40	2.25	0.30	LKG1H332MESYAK
	22 × 35	2.20	0.30	LKG1H332MESZAK
3900	20 × 45	2.45	0.30	LKG1H392MESYAK
	22 × 40	2.35	0.30	LKG1H392MESZAK
	25 × 30	2.50	0.30	LKG1H392MESAAK
	30 × 25	2.35	0.30	LKG1H392MESBAK
4700	35 × 20	2.45	0.30	LKG1H392MESCAK
	20 × 50	2.75	0.30	LKG1H472MESYAK
5600	22 × 45	2.60	0.30	LKG1H472MESZAK
	25 × 35	2.70	0.30	LKG1H472MESAAK
	22 × 50	2.90	0.30	LKG1H562MESZAK
6800	25 × 40	2.90	0.30	LKG1H562MESAAK
	30 × 30	3.00	0.30	LKG1H562MESBAK
	35 × 25	2.85	0.30	LKG1H562MESCAK
8200	25 × 45	3.30	0.30	LKG1H682MESAAK
	30 × 35	3.25	0.30	LKG1H682MESBAK
10000	30 × 40	3.55	0.30	LKG1H822MESBAK
	35 × 30	3.65	0.30	LKG1H822MESCAK
12000	30 × 45	4.00	0.30	LKG1H103MESBAK
	35 × 35	4.00	0.30	LKG1H103MESCAK
15000	35 × 40	4.35	0.30	LKG1H123MESCAK
15000	35 × 50	4.70	0.30	LKG1H153MESCAK

Rated ripple current (Arms) at 85°C 120Hz



## LKG

■ Dimensions (Snap-in Terminal Type : Grade TYPE- I )

63V(1J)				
Cap. (μF)	Size φD × L(mm)	Rated ripple (Arms)	tan δ	Code
820	22 × 20	1.30	0.30	LKG1J821MESZAK
1000	20 × 25	1.45	0.30	LKG1J102MESYAK
1200	25 × 20	1.65	0.30	LKG1J122MESAAK
1500	20 × 30	1.90	0.30	LKG1J152MESYAK
	22 × 25	1.90	0.30	LKG1J152MESZAK
1800	20 × 35	2.05	0.30	LKG1J182MESYAK
	22 × 30	2.00	0.30	LKG1J182MESZAK
	25 × 25	2.00	0.30	LKG1J182MESAAK
	30 × 20	2.05	0.30	LKG1J182MESBAK
	20 × 40	2.25	0.30	LKG1J222MESYAK
2200	22 × 35	2.20	0.30	LKG1J222MESZAK
	25 × 30	2.15	0.30	LKG1J222MESAAK
	35 × 20	2.10	0.30	LKG1J222MESCAK
2700	20 × 50	2.40	0.30	LKG1J272MESYAK
	22 × 40	2.45	0.30	LKG1J272MESZAK
	25 × 35	2.35	0.30	LKG1J272MESAAK
	30 × 25	2.50	0.30	LKG1J272MESBAK
3300	22 × 45	2.80	0.30	LKG1J332MESZAK
	25 × 40	2.60	0.30	LKG1J332MESAAK
	30 × 30	2.70	0.30	LKG1J332MESBAK
3900	25 × 45	2.85	0.30	LKG1J392MESAAK
	30 × 35	2.85	0.30	LKG1J392MESBAK
	35 × 25	3.00	0.30	LKG1J392MESCAK
4700	25 × 50	3.20	0.30	LKG1J472MESAAK
	30 × 40	3.10	0.30	LKG1J472MESBAK
	35 × 30	3.20	0.30	LKG1J472MESCAK
5600	30 × 45	3.45	0.30	LKG1J562MESBAK
	35 × 35	3.40	0.30	LKG1J562MESCAK
6800	30 × 50	3.90	0.30	LKG1J682MESBAK
	35 × 40	3.75	0.30	LKG1J682MESCAK
8200	35 × 45	4.20	0.30	LKG1J822MESCAK
10000	35 × 50	4.80	0.30	LKG1J103MESCAK

80V(1K)				
Cap. (μF)	Size φD × L(mm)	Rated ripple (Arms)	tan δ	Code
820	20 × 25	1.70	0.25	LKG1K821MESYAK
	25 × 20	1.65	0.25	LKG1K821MESAAK
1000	20 × 30	1.80	0.25	LKG1K102MESYAK
	22 × 25	1.85	0.25	LKG1K102MESZAK
1200	20 × 35	1.95	0.25	LKG1K122MESYAK
	22 × 30	1.95	0.25	LKG1K122MESZAK
	25 × 25	1.90	0.25	LKG1K122MESAAK
	30 × 20	2.00	0.25	LKG1K122MESBAK
1500	20 × 40	2.20	0.25	LKG1K152MESYAK
	22 × 35	2.15	0.25	LKG1K152MESZAK
	25 × 30	2.10	0.25	LKG1K152MESAAK
1800	20 × 45	2.45	0.25	LKG1K182MESYAK
	22 × 40	2.35	0.25	LKG1K182MESZAK
	30 × 25	2.40	0.25	LKG1K182MESBAK
	35 × 20	2.50	0.25	LKG1K182MESCAK
2200	22 × 45	2.70	0.25	LKG1K222MESZAK
	25 × 35	2.75	0.25	LKG1K222MESAAK
	30 × 30	2.55	0.25	LKG1K222MESBAK
2700	30 × 35	2.80	0.25	LKG1K272MESBAK
	35 × 25	3.00	0.25	LKG1K272MESCAK
3300	25 × 50	3.25	0.25	LKG1K332MESAAK
	30 × 40	3.15	0.25	LKG1K332MESBAK
	35 × 30	3.20	0.25	LKG1K332MESCAK
3900	30 × 45	3.45	0.25	LKG1K392MESBAK
	35 × 35	3.40	0.25	LKG1K392MESCAK
4700	30 × 45	3.85	0.25	LKG1K472MESBAK
	35 × 40	3.75	0.25	LKG1K472MESCAK
5600	35 × 45	4.10	0.25	LKG1K562MESCAK
6800	35 × 50	4.65	0.25	LKG1K682MESCAK

100V(2A)				
Cap. (μF)	Size φD × L(mm)	Rated ripple (Arms)	tan δ	Code
680	20 × 30	1.70	0.25	LKG2A681MESYAK
	22 × 25	1.75	0.25	LKG2A681MESZAK
820	20 × 35	1.85	0.25	LKG2A821MESYAK
	22 × 30	1.85	0.25	LKG2A821MESZAK
	25 × 25	1.80	0.25	LKG2A821MESAAK
	30 × 20	1.90	0.25	LKG2A821MESBAK
1000	20 × 40	2.05	0.25	LKG2A102MESYAK
1200	20 × 45	2.30	0.25	LKG2A122MESYAK
	22 × 40	2.20	0.25	LKG2A122MESZAK
	25 × 30	2.35	0.25	LKG2A122MESAAK
	30 × 25	2.20	0.25	LKG2A122MESBAK
	35 × 20	2.30	0.25	LKG2A122MESCAK
1500	20 × 50	2.65	0.25	LKG2A152MESYAK
	22 × 45	2.55	0.25	LKG2A152MESZAK
	25 × 35	2.60	0.25	LKG2A152MESAAK
1800	22 × 50	2.85	0.25	LKG2A182MESZAK
	25 × 40	2.85	0.25	LKG2A182MESAAK
	30 × 30	2.90	0.25	LKG2A182MESBAK
	35 × 25	2.75	0.25	LKG2A182MESCAK
2200	25 × 45	3.20	0.25	LKG2A222MESAAK
	30 × 35	3.20	0.25	LKG2A222MESBAK
	35 × 30	3.00	0.25	LKG2A222MESCAK
2700	30 × 40	3.55	0.25	LKG2A272MESBAK
	35 × 35	3.25	0.25	LKG2A272MESCAK
3300	30 × 50	3.75	0.25	LKG2A332MESBAK
3900	35 × 40	4.30	0.25	LKG2A392MESCAK
4700	35 × 50	4.50	0.25	LKG2A472MESCAK

Rated ripple current (Arms) at 85°C 120Hz

# ALUMINUM ELECTROLYTIC CAPACITORS

## LKG

■ Dimensions (Snap-in Terminal Type : Grade TYPE- II)

16V(1C)				
Cap. (μF)	Size φD × L(mm)	Rated ripple (Arms)	tan δ	Code
2200	20 × 20	1.10	0.35	LKG1C222MESYBK
3300	22 × 20	1.50	0.35	LKG1C332MESZBK
3900	20 × 25	1.55	0.35	LKG1C392MESYBK
	25 × 20	1.55	0.35	LKG1C392MESABK
4700	20 × 30	1.75	0.35	LKG1C472MESYBK
	22 × 25	1.75	0.35	LKG1C472MESZBK
5600	30 × 20	1.85	0.35	LKG1C562MESBBK
6800	20 × 35	2.20	0.35	LKG1C682MESYBK
	22 × 30	2.20	0.35	LKG1C682MESZBK
	25 × 25	2.15	0.35	LKG1C682MESABK
8200	20 × 40	2.40	0.35	LKG1C822MESYBK
	22 × 35	2.40	0.35	LKG1C822MESZBK
	25 × 30	2.30	0.35	LKG1C822MESABK
	35 × 20	2.25	0.35	LKG1C822MESCBK
10000	20 × 50	2.65	0.35	LKG1C103MESYBK
	22 × 40	2.65	0.35	LKG1C103MESZBK
	25 × 35	2.45	0.35	LKG1C103MESABK
	30 × 25	2.50	0.35	LKG1C103MESBBK
12000	22 × 50	2.75	0.35	LKG1C123MESZBK
	25 × 40	2.75	0.35	LKG1C123MESABK
	30 × 30	2.75	0.35	LKG1C123MESBBK
15000	35 × 25	2.60	0.35	LKG1C123MESCBK
	25 × 45	3.10	0.35	LKG1C153MESABK
	30 × 35	3.10	0.35	LKG1C153MESBBK
18000	25 × 50	3.50	0.35	LKG1C183MESABK
	30 × 40	3.40	0.35	LKG1C183MESBBK
	35 × 30	3.45	0.35	LKG1C183MESCBK
22000	30 × 45	3.80	0.35	LKG1C223MESBBK
	35 × 35	3.80	0.35	LKG1C223MESCBK
27000	30 × 50	4.25	0.45	LKG1C273MESBBK
	35 × 40	4.25	0.45	LKG1C273MESCBK
33000	35 × 45	4.50	0.57	LKG1C333MESCBK

35V(1V)				
Cap. (μF)	Size φD × L(mm)	Rated ripple (Arms)	tan δ	Code
1200	22 × 20	1.30	0.30	LKG1V122MESZBK
1500	20 × 25	1.40	0.30	LKG1V152MESYBK
1800	22 × 25	1.55	0.30	LKG1V182MESZBK
	25 × 20	1.65	0.30	LKG1V182MESABK
2200	20 × 30	1.75	0.30	LKG1V222MESYBK
2700	20 × 35	2.05	0.30	LKG1V272MESYBK
	22 × 30	2.05	0.30	LKG1V272MESZBK
	25 × 25	2.00	0.30	LKG1V272MESABK
	30 × 20	2.05	0.30	LKG1V272MESBBK
3300	20 × 40	2.25	0.30	LKG1V332MESYBK
	22 × 35	2.25	0.30	LKG1V332MESZBK
	25 × 30	2.20	0.30	LKG1V332MESABK
3900	20 × 45	2.40	0.30	LKG1V392MESYBK
	22 × 40	2.40	0.30	LKG1V392MESZBK
	25 × 35	2.30	0.30	LKG1V392MESABK
	30 × 25	2.40	0.30	LKG1V392MESBBK
4700	35 × 20	2.50	0.30	LKG1V392MESCBK
	22 × 45	2.70	0.30	LKG1V472MESZBK
5600	30 × 30	2.55	0.30	LKG1V472MESBBK
	22 × 50	3.00	0.30	LKG1V562MESZBK
6800	25 × 40	3.00	0.30	LKG1V562MESABK
	35 × 25	2.85	0.30	LKG1V562MESCBK
	25 × 50	3.10	0.30	LKG1V682MESABK
8200	30 × 35	3.30	0.30	LKG1V682MESBBK
	35 × 30	3.05	0.30	LKG1V682MESCBK
	30 × 40	3.60	0.30	LKG1V822MESBBK
10000	35 × 35	3.30	0.30	LKG1V822MESCBK
	30 × 50	3.80	0.30	LKG1V103MESBBK
12000	35 × 40	3.70	0.30	LKG1V103MESCBK
	35 × 45	4.10	0.30	LKG1V123MESCBK
15000	35 × 50	4.80	0.30	LKG1V153MESCBK

25V(1E)				
Cap. (μF)	Size φD × L(mm)	Rated ripple (Arms)	tan δ	Code
1800	20 × 20	1.35	0.30	LKG1E182MESYBK
2200	20 × 25	1.50	0.30	LKG1E222MESYBK
	25 × 20	1.50	0.30	LKG1E222MESABK
2700	20 × 30	1.70	0.30	LKG1E272MESYBK
	22 × 25	1.70	0.30	LKG1E272MESZBK
3300	20 × 35	1.80	0.30	LKG1E332MESYBK
	22 × 30	1.80	0.30	LKG1E332MESZBK
	30 × 20	1.85	0.30	LKG1E332MESBBK
3900	25 × 25	2.10	0.30	LKG1E392MESABK
4700	20 × 45	2.30	0.30	LKG1E472MESYBK
	22 × 35	2.30	0.30	LKG1E472MESZBK
	25 × 30	2.25	0.30	LKG1E472MESABK
5600	35 × 20	2.20	0.30	LKG1E472MESCBK
	20 × 50	2.50	0.30	LKG1E562MESYBK
	22 × 40	2.50	0.30	LKG1E562MESZBK
	25 × 35	2.40	0.30	LKG1E562MESABK
6800	30 × 25	2.50	0.30	LKG1E562MESBBK
	22 × 50	2.65	0.30	LKG1E682MESZBK
	25 × 40	2.65	0.30	LKG1E682MESABK
8200	30 × 30	2.65	0.30	LKG1E682MESBBK
	25 × 45	2.90	0.30	LKG1E822MESABK
	30 × 35	2.85	0.30	LKG1E822MESBBK
10000	35 × 25	3.05	0.30	LKG1E822MESCBK
	25 × 50	3.30	0.30	LKG1E103MESABK
	30 × 40	3.30	0.30	LKG1E103MESBBK
12000	35 × 30	3.30	0.30	LKG1E103MESCBK
	30 × 45	3.55	0.30	LKG1E123MESBBK
15000	35 × 35	3.50	0.30	LKG1E123MESCBK
	30 × 50	4.15	0.30	LKG1E153MESBBK
18000	35 × 40	4.00	0.30	LKG1E153MESCBK
	35 × 45	4.45	0.30	LKG1E183MESCBK

50V(1H)				
Cap. (μF)	Size φD × L(mm)	Rated ripple (Arms)	tan δ	Code
820	22 × 20	1.00	0.30	LKG1H821MESZBK
1000	20 × 25	1.50	0.30	LKG1H102MESYBK
	25 × 20	1.50	0.30	LKG1H102MESABK
1200	20 × 30	1.65	0.30	LKG1H122MESYBK
	22 × 25	1.65	0.30	LKG1H122MESZBK
1500	20 × 35	1.80	0.30	LKG1H152MESYBK
	22 × 30	1.80	0.30	LKG1H152MESZBK
	30 × 20	1.80	0.30	LKG1H152MESBBK
1800	25 × 25	2.15	0.30	LKG1H182MESABK
2200	20 × 45	2.35	0.30	LKG1H222MESYBK
	22 × 35	2.35	0.30	LKG1H222MESZBK
	25 × 30	2.30	0.30	LKG1H222MESABK
2700	35 × 20	2.25	0.30	LKG1H222MESCBK
	20 × 50	2.45	0.30	LKG1H272MESYBK
	22 × 45	2.45	0.30	LKG1H272MESZBK
3300	25 × 35	2.50	0.30	LKG1H272MESABK
	30 × 25	2.60	0.30	LKG1H272MESBBK
	22 × 50	2.80	0.30	LKG1H332MESZBK
3900	25 × 40	2.80	0.30	LKG1H332MESABK
	30 × 30	2.80	0.30	LKG1H332MESBBK
	25 × 45	3.00	0.30	LKG1H392MESABK
4700	30 × 35	3.00	0.30	LKG1H392MESBBK
	35 × 25	3.15	0.30	LKG1H392MESCBK
	25 × 50	3.40	0.30	LKG1H472MESABK
5600	30 × 40	3.30	0.30	LKG1H472MESBBK
	35 × 30	3.35	0.30	LKG1H472MESCBK
	30 × 45	3.60	0.30	LKG1H562MESBBK
6800	35 × 35	3.60	0.30	LKG1H562MESCBK
	30 × 50	4.10	0.30	LKG1H682MESBBK
8200	35 × 40	3.95	0.30	LKG1H682MESCBK
	35 × 45	4.40	0.30	LKG1H822MESCBK
10000	35 × 50	5.05	0.30	LKG1H103MESCBK

Rated ripple current (Arms) at 85°C 120Hz

CAT.8100K

## LKG

■ Dimensions (Snap-in Terminal Type : Grade TYPE-II)

63V(1J)				
Cap. (μF)	Size φD × L(mm)	Rated ripple (Arms)	tan δ	Code
820	20 × 25	1.65	0.30	LKG1J821MESYBK
	25 × 20	1.65	0.30	LKG1J821MESABK
1000	20 × 30	1.85	0.30	LKG1J102MESYBK
	22 × 25	1.85	0.30	LKG1J102MESZBK
1200	20 × 35	1.95	0.30	LKG1J122MESYBK
	22 × 30	1.95	0.30	LKG1J122MESZBK
	25 × 25	1.90	0.30	LKG1J122MESABK
	30 × 20	1.95	0.30	LKG1J122MESBBK
1500	20 × 40	2.15	0.30	LKG1J152MESYBK
	22 × 35	2.15	0.30	LKG1J152MESZBK
	25 × 30	2.10	0.30	LKG1J152MESABK
1800	20 × 45	2.35	0.30	LKG1J182MESYBK
	22 × 40	2.35	0.30	LKG1J182MESZBK
	30 × 25	2.35	0.30	LKG1J182MESBBK
2200	35 × 20	2.45	0.30	LKG1J182MESCBK
	22 × 45	2.70	0.30	LKG1J222MESZBK
	25 × 35	2.75	0.30	LKG1J222MESABK
2700	30 × 30	2.50	0.30	LKG1J222MESBBK
	25 × 45	2.80	0.30	LKG1J272MESABK
	30 × 35	2.75	0.30	LKG1J272MESBBK
3300	35 × 25	2.95	0.30	LKG1J272MESCBK
	25 × 50	3.20	0.30	LKG1J332MESABK
	30 × 40	3.20	0.30	LKG1J332MESBBK
3900	35 × 30	3.15	0.30	LKG1J332MESCBK
	30 × 45	3.35	0.30	LKG1J392MESBBK
4700	35 × 35	3.35	0.30	LKG1J392MESCBK
5600	30 × 50	3.80	0.30	LKG1J472MESBBK
6800	35 × 40	4.35	0.30	LKG1J562MESCBK
	35 × 50	4.60	0.30	LKG1J682MESCBK

80V(1K)				
Cap. (μF)	Size φD × L(mm)	Rated ripple (Arms)	tan δ	Code
820	20 × 35	2.05	0.25	LKG1K821MESYBK
	22 × 30	2.05	0.25	LKG1K821MESZBK
	25 × 25	2.00	0.25	LKG1K821MESABK
	30 × 20	2.05	0.25	LKG1K821MESBBK
1000	20 × 45	2.20	0.25	LKG1K102MESYBK
	22 × 35	2.20	0.25	LKG1K102MESZBK
	25 × 30	2.15	0.25	LKG1K102MESABK
	35 × 20	2.10	0.25	LKG1K102MESCBK
	20 × 50	2.45	0.25	LKG1K122MESYBK
1200	22 × 40	2.45	0.25	LKG1K122MESZBK
	25 × 35	2.30	0.25	LKG1K122MESABK
	30 × 25	2.40	0.25	LKG1K122MESBBK
1500	22 × 50	2.60	0.25	LKG1K152MESZBK
	25 × 40	2.65	0.25	LKG1K152MESABK
	30 × 30	2.65	0.25	LKG1K152MESBBK
1800	25 × 45	2.85	0.25	LKG1K182MESABK
	30 × 35	2.85	0.25	LKG1K182MESBBK
	35 × 25	3.00	0.25	LKG1K182MESCBK
2200	25 × 50	3.25	0.25	LKG1K222MESABK
	30 × 40	3.15	0.25	LKG1K222MESBBK
	35 × 30	3.25	0.25	LKG1K222MESCBK
2700	30 × 45	3.60	0.25	LKG1K272MESBBK
	35 × 35	3.55	0.25	LKG1K272MESCBK
3300	30 × 50	4.10	0.25	LKG1K332MESBBK
	35 × 40	3.95	0.25	LKG1K332MESCBK
3900	35 × 45	4.35	0.25	LKG1K392MESCBK
4700	35 × 50	4.85	0.25	LKG1K472MESCBK

100V(2A)				
Cap. (μF)	Size φD × L(mm)	Rated ripple (Arms)	tan δ	Code
680	20 × 40	2.15	0.25	LKG2A681MESYBK
	22 × 35	2.15	0.25	LKG2A681MESZBK
	25 × 30	2.10	0.25	LKG2A681MESABK
820	20 × 45	2.40	0.25	LKG2A821MESYBK
	22 × 40	2.40	0.25	LKG2A821MESZBK
	30 × 25	2.35	0.25	LKG2A821MESBBK
	35 × 20	2.45	0.25	LKG2A821MESCBK
1000	22 × 45	2.70	0.25	LKG2A102MESZBK
	25 × 35	2.75	0.25	LKG2A102MESABK
1200	22 × 50	3.00	0.25	LKG2A122MESZBK
	25 × 40	2.75	0.25	LKG2A122MESABK
	30 × 30	3.05	0.25	LKG2A122MESBBK
	35 × 25	2.90	0.25	LKG2A122MESCBK
1500	25 × 50	3.20	0.25	LKG2A152MESABK
	30 × 35	3.40	0.25	LKG2A152MESBBK
	35 × 30	3.20	0.25	LKG2A152MESCBK
1800	30 × 40	3.70	0.25	LKG2A182MESBBK
	35 × 35	3.40	0.25	LKG2A182MESCBK
2200	30 × 50	3.95	0.25	LKG2A222MESBBK
	35 × 40	3.80	0.25	LKG2A222MESCBK
2700	35 × 45	4.30	0.25	LKG2A272MESCBK
3300	35 × 50	4.95	0.25	LKG2A332MESCBK

Rated ripple current (Arms) at 85°C 120Hz

## LKG

■ Dimensions (Snap-in Terminal Type : Grade TYPE-III)

16V(1C)				
Cap. (μF)	Size φD × L(mm)	Rated ripple (Arms)	tan δ	Code
1000	20 × 20	0.90	0.25	LKG1C102MESYCK
1200	22 × 20	0.95	0.25	LKG1C122MESZCK
1500	20 × 25	1.10	0.25	LKG1C152MESYCK
	25 × 20	1.10	0.25	LKG1C152MESACK
1800	22 × 25	1.20	0.25	LKG1C182MESZCK
2200	20 × 30	1.35	0.25	LKG1C222MESYCK
	30 × 20	1.35	0.25	LKG1C222MESBCK
2700	20 × 35	1.75	0.25	LKG1C272MESYCK
	25 × 25	1.75	0.25	LKG1C272MESACK
3300	20 × 40	2.00	0.25	LKG1C332MESYCK
	25 × 30	2.00	0.25	LKG1C332MESACK
	35 × 20	1.95	0.25	LKG1C332MESCK
3900	20 × 50	2.30	0.25	LKG1C392MESYCK
	22 × 45	2.30	0.25	LKG1C392MESZCK
	25 × 35	2.35	0.25	LKG1C392MESACK
4700	30 × 25	2.35	0.25	LKG1C392MESBCK
	22 × 50	2.75	0.25	LKG1C472MESZCK
	25 × 40	2.70	0.25	LKG1C472MESACK
	30 × 30	2.70	0.25	LKG1C472MESBCK
5600	35 × 25	2.60	0.25	LKG1C472MESCK
	25 × 45	2.90	0.25	LKG1C562MESACK
	30 × 35	2.90	0.25	LKG1C562MESBCK
6800	25 × 50	3.20	0.25	LKG1C682MESACK
	30 × 40	3.20	0.25	LKG1C682MESBCK
	35 × 30	3.15	0.25	LKG1C682MESCK
8200	30 × 45	3.35	0.25	LKG1C822MESBCK
	35 × 35	3.30	0.25	LKG1C822MESCK
10000	35 × 40	3.50	0.25	LKG1C103MESCK
12000	35 × 45	3.70	0.25	LKG1C123MESCK

25V(1E)				
Cap. (μF)	Size φD × L(mm)	Rated ripple (Arms)	tan δ	Code
680	20 × 20	0.65	0.22	LKG1E681MESYCK
820	22 × 20	0.75	0.22	LKG1E821MESZCK
1000	25 × 20	0.95	0.22	LKG1E102MESACK
1200	20 × 25	1.20	0.22	LKG1E122MESYCK
1500	20 × 30	1.30	0.22	LKG1E152MESYCK
	30 × 20	1.30	0.22	LKG1E152MESBCK
1800	20 × 35	1.60	0.22	LKG1E182MESYCK
	25 × 25	1.55	0.22	LKG1E182MESACK
2200	20 × 40	1.85	0.22	LKG1E222MESYCK
	22 × 35	1.85	0.22	LKG1E222MESZCK
	25 × 30	1.80	0.22	LKG1E222MESACK
	30 × 25	1.80	0.22	LKG1E222MESBCK
2700	35 × 20	1.75	0.22	LKG1E222MESCK
	20 × 50	2.20	0.22	LKG1E272MESYCK
	22 × 45	2.20	0.22	LKG1E272MESZCK
3300	25 × 35	2.15	0.22	LKG1E272MESACK
	22 × 50	2.50	0.22	LKG1E332MESZCK
	25 × 40	2.45	0.22	LKG1E332MESACK
	30 × 30	2.40	0.22	LKG1E332MESBCK
3900	35 × 25	2.45	0.22	LKG1E332MESCK
	25 × 45	2.80	0.22	LKG1E392MESACK
	30 × 35	2.80	0.22	LKG1E392MESBCK
4700	30 × 40	3.25	0.22	LKG1E472MESBCK
	35 × 30	3.15	0.22	LKG1E472MESCK
5600	30 × 45	3.50	0.22	LKG1E562MESBCK
	35 × 35	3.50	0.22	LKG1E562MESCK
6800	35 × 40	3.80	0.22	LKG1E682MESCK
8200	35 × 45	4.00	0.22	LKG1E822MESCK

35V(1V)				
Cap. (μF)	Size φD × L(mm)	Rated ripple (Arms)	tan δ	Code
820	20 × 25	0.85	0.22	LKG1V821MESYCK
	25 × 20	0.85	0.22	LKG1V821MESACK
1000	20 × 30	1.05	0.22	LKG1V102MESYCK
	22 × 25	1.00	0.22	LKG1V102MESZCK
1200	20 × 35	1.45	0.22	LKG1V122MESYCK
	22 × 30	1.45	0.22	LKG1V122MESZCK
	25 × 25	1.40	0.22	LKG1V122MESACK
	30 × 20	1.40	0.22	LKG1V122MESBCK
1500	20 × 40	1.55	0.22	LKG1V152MESYCK
	22 × 35	1.55	0.22	LKG1V152MESZCK
	25 × 30	1.50	0.22	LKG1V152MESACK
1800	20 × 45	1.80	0.22	LKG1V182MESYCK
	22 × 40	1.75	0.22	LKG1V182MESZCK
	30 × 25	1.75	0.22	LKG1V182MESBCK
	35 × 20	1.70	0.22	LKG1V182MESCK
2200	20 × 50	2.00	0.22	LKG1V222MESYCK
	22 × 45	1.95	0.22	LKG1V222MESZCK
	25 × 35	1.95	0.22	LKG1V222MESACK
	30 × 30	1.95	0.22	LKG1V222MESBCK
2700	25 × 45	2.35	0.22	LKG1V272MESACK
	30 × 35	2.30	0.22	LKG1V272MESBCK
	35 × 25	2.30	0.22	LKG1V272MESCK
3300	25 × 50	2.70	0.22	LKG1V332MESACK
	30 × 40	2.70	0.22	LKG1V332MESBCK
	35 × 30	2.65	0.22	LKG1V332MESCK
3900	30 × 45	3.00	0.22	LKG1V392MESBCK
	35 × 35	3.00	0.22	LKG1V392MESCK
4700	30 × 50	3.55	0.22	LKG1V472MESBCK
	35 × 40	3.55	0.22	LKG1V472MESCK
5600	35 × 45	3.80	0.22	LKG1V562MESCK
6800	35 × 50	4.15	0.22	LKG1V682MESCK

50V(1H)				
Cap. (μF)	Size φD × L(mm)	Rated ripple (Arms)	tan δ	Code
680	20 × 30	1.05	0.22	LKG1H681MESYCK
	22 × 25	1.00	0.22	LKG1H681MESZCK
820	22 × 30	1.40	0.22	LKG1H821MESZCK
	25 × 25	1.35	0.22	LKG1H821MESACK
	30 × 20	1.35	0.22	LKG1H821MESBCK
1000	20 × 35	1.80	0.22	LKG1H102MESYCK
	20 × 40	1.95	0.22	LKG1H122MESYCK
	25 × 30	1.95	0.22	LKG1H122MESACK
1200	30 × 25	1.90	0.22	LKG1H122MESBCK
	35 × 20	1.90	0.22	LKG1H122MESCK
	20 × 50	2.20	0.22	LKG1H152MESYCK
1500	22 × 45	2.20	0.22	LKG1H152MESZCK
	25 × 35	2.15	0.22	LKG1H152MESACK
	30 × 30	2.15	0.22	LKG1H152MESBCK
	22 × 50	2.45	0.22	LKG1H182MESZCK
1800	25 × 40	2.45	0.22	LKG1H182MESACK
	35 × 25	2.40	0.22	LKG1H182MESCK
	25 × 50	2.65	0.22	LKG1H222MESACK
2200	30 × 35	2.60	0.22	LKG1H222MESBCK
	35 × 30	2.60	0.22	LKG1H222MESCK
	30 × 45	3.00	0.22	LKG1H272MESBCK
2700	35 × 35	2.95	0.22	LKG1H272MESCK
	30 × 50	3.30	0.22	LKG1H332MESBCK
3300	35 × 40	3.25	0.22	LKG1H332MESCK
	3900	35 × 45	3.50	0.22
4700	35 × 50	3.90	0.22	LKG1H472MESCK

Rated ripple current (Arms) at 85°C 120Hz

## LKG

■ Dimensions (Snap-in Terminal Type : Grade TYPE-III)

63V(1J)				
Cap. (μF)	Size φD × L(mm)	Rated ripple (Arms)	tan δ	Code
680	20 × 30	1.75	0.22	LKG1J681MESYCK
	22 × 25	1.75	0.22	LKG1J681MESZCK
	30 × 20	1.90	0.22	LKG1J681MESBCK
820	20 × 35	1.90	0.22	LKG1J821MESYCK
	22 × 30	1.90	0.22	LKG1J821MESZCK
	25 × 25	1.85	0.22	LKG1J821MESACK
1000	20 × 40	2.10	0.22	LKG1J102MESYCK
	22 × 35	2.05	0.22	LKG1J102MESZCK
	25 × 30	2.00	0.22	LKG1J102MESACK
1200	20 × 45	2.35	0.22	LKG1J122MESYCK
	22 × 40	2.25	0.22	LKG1J122MESZCK
	30 × 25	2.20	0.22	LKG1J122MESBCK
	35 × 20	2.30	0.22	LKG1J122MESACK
1500	22 × 45	2.60	0.22	LKG1J152MESZCK
	25 × 35	2.65	0.22	LKG1J152MESACK
1800	22 × 50	2.90	0.22	LKG1J182MESZCK
	25 × 40	2.90	0.22	LKG1J182MESACK
	30 × 30	2.90	0.22	LKG1J182MESBCK
	35 × 25	2.75	0.22	LKG1J182MESACK
2200	25 × 45	3.25	0.22	LKG1J222MESACK
	30 × 35	3.20	0.22	LKG1J222MESBCK
2700	30 × 45	3.30	0.22	LKG1J272MESBCK
	35 × 30	3.65	0.22	LKG1J272MESACK
3300	30 × 50	3.80	0.22	LKG1J332MESBCK
	35 × 35	4.00	0.22	LKG1J332MESACK
3900	35 × 40	4.30	0.22	LKG1J392MESACK
4700	35 × 50	4.50	0.22	LKG1J472MESACK

80V(1K)				
Cap. (μF)	Size φD × L(mm)	Rated ripple (Arms)	tan δ	Code
680	20 × 45	2.10	0.20	LKG1K681MESYCK
	22 × 35	2.25	0.20	LKG1K681MESZCK
	25 × 30	2.15	0.20	LKG1K681MESACK
820	20 × 50	2.40	0.20	LKG1K821MESYCK
	22 × 40	2.45	0.20	LKG1K821MESZCK
	25 × 35	2.35	0.20	LKG1K821MESACK
	30 × 25	2.40	0.20	LKG1K821MESBCK
1000	35 × 20	2.55	0.20	LKG1K821MESACK
	22 × 50	2.60	0.20	LKG1K102MESZCK
	25 × 40	2.60	0.20	LKG1K102MESACK
1200	30 × 30	2.60	0.20	LKG1K102MESBCK
	25 × 45	2.85	0.20	LKG1K122MESACK
	30 × 35	2.80	0.20	LKG1K122MESBCK
1500	35 × 25	2.95	0.20	LKG1K122MESACK
	25 × 50	3.30	0.20	LKG1K152MESACK
	30 × 40	3.20	0.20	LKG1K152MESBCK
1800	35 × 30	3.25	0.20	LKG1K152MESACK
	30 × 45	3.55	0.20	LKG1K182MESBCK
	35 × 35	3.50	0.20	LKG1K182MESACK
2200	30 × 50	4.05	0.20	LKG1K222MESBCK
	35 × 40	3.90	0.20	LKG1K222MESACK
2700	35 × 45	4.45	0.20	LKG1K272MESACK
3300	35 × 50	5.05	0.20	LKG1K332MESACK

100V(2A)				
Cap. (μF)	Size φD × L(mm)	Rated ripple (Arms)	tan δ	Code
680	22 × 45	2.65	0.20	LKG2A681MESZCK
	25 × 35	2.70	0.20	LKG2A681MESACK
820	22 × 50	3.00	0.20	LKG2A821MESZCK
	25 × 40	3.00	0.20	LKG2A821MESACK
	30 × 30	3.00	0.20	LKG2A821MESBCK
	35 × 25	2.85	0.20	LKG2A821MESACK
1000	25 × 50	3.10	0.20	LKG2A102MESACK
	30 × 35	3.30	0.20	LKG2A102MESBCK
	35 × 30	3.05	0.20	LKG2A102MESACK
1200	30 × 40	3.60	0.20	LKG2A122MESBCK
	35 × 35	3.30	0.20	LKG2A122MESACK
1500	30 × 50	3.90	0.20	LKG2A152MESBCK
	35 × 40	3.75	0.20	LKG2A152MESACK
1800	35 × 45	4.15	0.20	LKG2A182MESACK
2200	35 × 50	4.75	0.20	LKG2A222MESACK

Rated ripple current (Arms) at 85°C 120Hz

## LKG

### ■ Dimensions (Lug Terminal Type : Grade TYPE- I )

Rated Voltage (V)(code)	Cap. (μF)	Size φD × L(mm)	Rated ripple (Arms)	tan δ	Code
50V(1H)	22000	40 × 68	5.40	0.30	LKG1H223MKNF
63V(1J)	15000	40 × 68	5.60	0.30	LKG1J153MKNF
	22000	40 × 100	6.60	0.30	LKG1J223MKNF
80V(1K)	10000	40 × 68	5.40	0.25	LKG1K103MKNF
	15000	40 × 100	6.50	0.25	LKG1K153MKNF
	22000	50 × 100	7.80	0.25	LKG1K223MKZF
100V(2A)	6800	40 × 68	5.10	0.25	LKG2A682MKNF
	10000	40 × 100	6.00	0.25	LKG2A103MKNF
	15000	50 × 100	7.40	0.25	LKG2A153MKZF
	22000	63 × 80	9.70	0.25	LKG2A223MKZF

### ■ Dimensions (Lug Terminal Type : Grade TYPE- II )

Rated Voltage (V)(code)	Cap. (μF)	Size φD × L(mm)	Rated ripple (Arms)	tan δ	Code
50(1H)	10000	35 × 80	4.60	0.30	LKG1H103MKN
	15000	40 × 80	6.10	0.30	LKG1H153MKN
	22000	50 × 80	8.30	0.30	LKG1H223MKZ
63(1J)	6800	35 × 68	4.30	0.30	LKG1J682MKN
	10000	40 × 80	4.90	0.30	LKG1J103MKN
	15000	40 × 100	6.70	0.30	LKG1J153MKN
	22000	50 × 100	9.10	0.30	LKG1J223MKZ
80(1K)	6800	40 × 100	6.10	0.25	LKG1K682MKN
	10000	50 × 80	6.20	0.25	LKG1K103MKZ
	15000	50 × 100	8.40	0.25	LKG1K153MKZ
	22000	63 × 100	11.6	0.25	LKG1K223MKZ
100(2A)	6800	50 × 80	6.20	0.25	LKG2A682MKZ
	10000	50 × 100	6.90	0.25	LKG2A103MKZ
	15000	63 × 80	8.70	0.25	LKG2A153MKZ
	22000	76 × 100	12.9	0.25	LKG2A223MKZ

### ■ Dimensions (Lug Terminal Type : Grade TYPE- III )

Rated Voltage (V)(code)	Cap. (μF)	Size φD × L(mm)	Rated ripple (Arms)	tan δ	Code
50(1H)	6800	40 × 80	5.50	0.22	LKG1H682MKNS
	10000	40 × 100	6.10	0.22	LKG1H103MKNS
	15000	50 × 100	8.40	0.22	LKG1H153MKZS
	22000	63 × 80	10.5	0.22	LKG1H223MKZS
63(1J)	6800	40 × 100	6.10	0.22	LKG1J682MKNS
	10000	50 × 80	6.20	0.22	LKG1J103MKZS
	15000	63 × 80	8.70	0.22	LKG1J153MKZS
	22000	63 × 100	11.6	0.22	LKG1J223MKZS
80(1K)	6800	50 × 80	6.70	0.20	LKG1K682MKZS
	10000	63 × 80	7.60	0.20	LKG1K103MKZS
	15000	63 × 100	10.1	0.20	LKG1K153MKZS
	22000	76 × 100	13.7	0.20	LKG1K223MKZS
100(2A)	6800	50 × 100	7.30	0.20	LKG2A682MKZS
	10000	63 × 100	8.30	0.20	LKG2A103MKZS
	15000	76 × 100	11.3	0.20	LKG2A153MKZS

Rated ripple current (Arms) at 85°C 120Hz

# ALUMINUM ELECTROLYTIC CAPACITORS

# LKS

Snap-in Terminal Type,  
For Audio Equipment, Smaller-sized



- Smaller and high-tone quality than LKG TYPE- I grade.
- An effect to tone quality improvement by replacement from a small standard product to use.
- Compliant to the RoHS directive (2011/65/EU,(EU)2015/863).



**LKS**

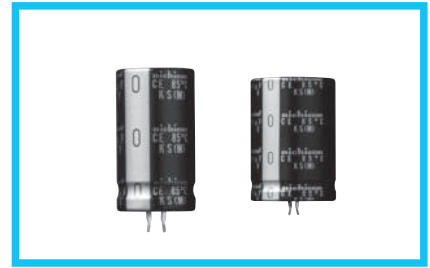

## Specifications

Item	Performance Characteristics				
Category Temperature Range	- 40 to +85°C				
Rated Voltage Range	25 to 100V				
Rated Capacitance Range	680 to 33000μF				
Capacitance Tolerance	±20% at 120Hz, 20°C				
Leakage Current	After 5 minutes' application of rated voltage at 20°C, leakage current is not more than $3\sqrt{CV}$ (μA), [C: Rated Capacitance(μF), V: Voltage (V)]				
Tangent of loss angle (tan δ)	See refer to next page (Measurement frequency : 120Hz at 20°C)				
Stability at Low Temperature	Rated voltage(V)	25 to 100			
	Impedance ratio ZT/Z20(MAX.)	<table border="1"> <tr> <td>Z - 25°C/Z+20°C</td> <td>4</td> </tr> <tr> <td>Z - 40°C/Z+20°C</td> <td>12</td> </tr> </table>	Z - 25°C/Z+20°C	4	Z - 40°C/Z+20°C
Z - 25°C/Z+20°C	4				
Z - 40°C/Z+20°C	12				
Endurance	The specifications listed at right shall be met when the capacitors are restored to 20°C after the rated voltage is applied for 1000 hours at 85°C.				
	Capacitance change	Within ±20% of the initial value			
	tan δ	200% or less than the initial specified value			
Shelf Life	After storing the capacitors under no load at 85°C for 1000 hours and then performing voltage treatment based on JIS C 5101-4 clause 4.1 at 20°C, they shall meet the specified values for the endurance characteristics listed above.				
	Leakage current	Less than or equal to the initial specified value			
Marking	Printed with silver color letter on black sleeve.				

## Drawing

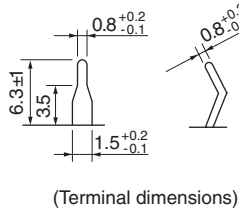
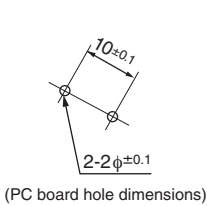
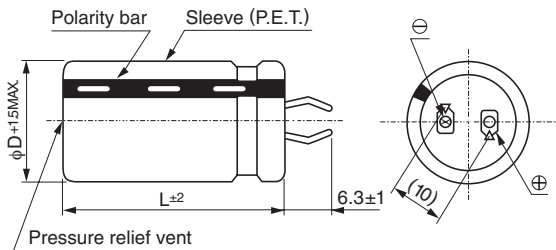

## Type numbering system (Example : 35 V 8200μF)

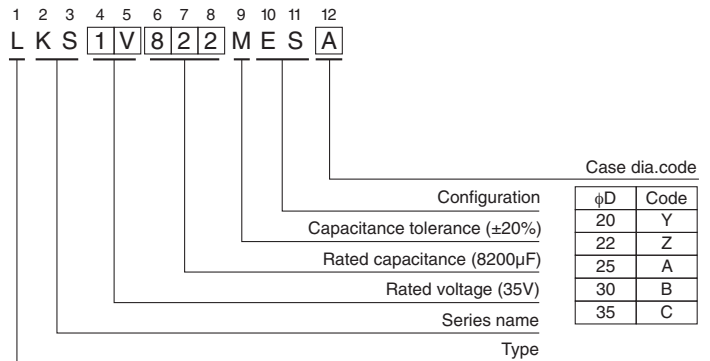

● Dimension table in next page.

## LKS

### ■ Dimensions

25V (1E)				
Cap. (μF)	Size φD × L (mm)	Rated ripple (Arms)	tan δ	Code
3300	22 × 20	1.40	0.30	LKS1E332MESZ
4700	20 × 25	1.50	0.30	LKS1E472MESY
	25 × 20	1.50	0.30	LKS1E472MESA
5600	20 × 30	1.65	0.30	LKS1E562MESY
	22 × 25	1.65	0.30	LKS1E562MESZ
6800	20 × 35	1.95	0.30	LKS1E682MESY
	22 × 30	1.95	0.30	LKS1E682MESZ
	25 × 25	1.95	0.30	LKS1E682MESA
	30 × 20	1.95	0.30	LKS1E682MESB
8200	20 × 40	2.25	0.30	LKS1E822MESY
	22 × 35	2.25	0.30	LKS1E822MESZ
10000	20 × 45	2.45	0.30	LKS1E103MESY
	22 × 40	2.45	0.30	LKS1E103MESZ
	25 × 30	2.45	0.30	LKS1E103MESA
	30 × 25	2.45	0.30	LKS1E103MESB
	35 × 20	2.45	0.30	LKS1E103MESB
12000	20 × 50	2.65	0.30	LKS1E123MESY
	22 × 45	2.65	0.30	LKS1E123MESZ
	25 × 35	2.65	0.30	LKS1E123MESA
	30 × 30	2.65	0.30	LKS1E123MESB
	35 × 25	2.65	0.30	LKS1E123MESB
15000	22 × 50	3.00	0.30	LKS1E153MESZ
	25 × 40	3.00	0.30	LKS1E153MESA
18000	25 × 50	3.35	0.30	LKS1E183MESA
	30 × 35	3.35	0.30	LKS1E183MESB
	35 × 30	3.35	0.30	LKS1E183MESB
22000	30 × 45	3.75	0.30	LKS1E223MESB
	35 × 35	3.75	0.30	LKS1E223MESB
27000	30 × 50	4.20	0.40	LKS1E273MESB
	35 × 40	4.20	0.40	LKS1E273MESB
33000	35 × 45	4.60	0.52	LKS1E333MESB

35V (1V)				
Cap. (μF)	Size φD × L (mm)	Rated ripple (Arms)	tan δ	Code
2200	22 × 20	1.40	0.30	LKS1V222MESZ
3300	20 × 25	1.50	0.30	LKS1V332MESY
	25 × 20	1.50	0.30	LKS1V332MESA
3900	20 × 30	1.70	0.30	LKS1V392MESY
	22 × 25	1.70	0.30	LKS1V392MESZ
4700	20 × 35	2.10	0.30	LKS1V472MESY
	22 × 30	2.10	0.30	LKS1V472MESZ
	30 × 20	2.10	0.30	LKS1V472MESB
5600	20 × 40	2.25	0.30	LKS1V562MESY
	22 × 35	2.25	0.30	LKS1V562MESZ
	25 × 25	2.25	0.30	LKS1V562MESA
6800	20 × 45	2.50	0.30	LKS1V682MESY
	22 × 40	2.50	0.30	LKS1V682MESZ
	25 × 30	2.50	0.30	LKS1V682MESA
	35 × 20	2.50	0.30	LKS1V682MESB
8200	20 × 50	2.70	0.30	LKS1V822MESY
	22 × 45	2.70	0.30	LKS1V822MESZ
	25 × 35	2.70	0.30	LKS1V822MESA
10000	30 × 25	2.70	0.30	LKS1V822MESB
	22 × 50	2.95	0.30	LKS1V103MESZ
	25 × 40	2.95	0.30	LKS1V103MESA
	30 × 30	2.95	0.30	LKS1V103MESB
	35 × 25	2.95	0.30	LKS1V103MESB
12000	25 × 45	3.25	0.30	LKS1V123MESA
	30 × 35	3.25	0.30	LKS1V123MESB
	35 × 30	3.25	0.30	LKS1V123MESB
15000	30 × 40	3.70	0.30	LKS1V153MESB
18000	30 × 50	4.05	0.30	LKS1V183MESB
	35 × 35	4.05	0.30	LKS1V183MESB
22000	35 × 40	4.40	0.30	LKS1V223MESB
27000	35 × 50	4.80	0.40	LKS1V273MESB

42V (A2)				
Cap. (μF)	Size φD × L (mm)	Rated ripple (Arms)	tan δ	Code
1800	22 × 20	1.40	0.30	LKSA2182MESZ
2200	20 × 25	1.55	0.30	LKSA2222MESY
	25 × 20	1.55	0.30	LKSA2222MESA
2700	20 × 30	1.70	0.30	LKSA2272MESY
	22 × 25	1.70	0.30	LKSA2272MESZ
3300	20 × 35	2.00	0.30	LKSA2332MESY
	22 × 30	2.00	0.30	LKSA2332MESZ
	30 × 20	2.00	0.30	LKSA2332MESB
3900	25 × 25	2.25	0.30	LKSA2392MESA
	20 × 40	2.50	0.30	LKSA2472MESY
4700	22 × 35	2.50	0.30	LKSA2472MESZ
	25 × 30	2.50	0.30	LKSA2472MESA
	35 × 20	2.50	0.30	LKSA2472MESB
	20 × 50	2.70	0.30	LKSA2562MESY
5600	22 × 40	2.70	0.30	LKSA2562MESZ
	25 × 35	2.70	0.30	LKSA2562MESA
	30 × 25	2.70	0.30	LKSA2562MESB
6800	22 × 45	2.90	0.30	LKSA2682MESZ
	25 × 40	2.90	0.30	LKSA2682MESA
	30 × 30	2.90	0.30	LKSA2682MESB
8200	35 × 25	2.90	0.30	LKSA2682MESB
	25 × 45	3.20	0.30	LKSA2822MESA
	30 × 35	3.20	0.30	LKSA2822MESB
10000	25 × 50	3.50	0.30	LKSA2103MESA
	30 × 40	3.50	0.30	LKSA2103MESB
	35 × 30	3.50	0.30	LKSA2103MESB
12000	30 × 45	3.80	0.30	LKSA2123MESB
	35 × 35	3.80	0.30	LKSA2123MESB
15000	30 × 50	4.15	0.30	LKSA2153MESB
	35 × 40	4.15	0.30	LKSA2153MESB
18000	35 × 45	4.50	0.30	LKSA2183MESB

50V (1H)				
Cap. (μF)	Size φD × L (mm)	Rated ripple (Arms)	tan δ	Code
1500	22 × 20	1.45	0.30	LKS1H152MESZ
1800	20 × 25	1.60	0.30	LKS1H182MESY
	20 × 30	1.75	0.30	LKS1H222MESY
2200	22 × 25	1.75	0.30	LKS1H222MESZ
	25 × 20	1.75	0.30	LKS1H222MESA
2700	30 × 20	1.90	0.30	LKS1H272MESB
	20 × 35	2.15	0.30	LKS1H332MESY
3300	22 × 30	2.15	0.30	LKS1H332MESZ
	25 × 25	2.15	0.30	LKS1H332MESA
	20 × 40	2.30	0.30	LKS1H392MESY
3900	22 × 35	2.30	0.30	LKS1H392MESZ
	25 × 30	2.30	0.30	LKS1H392MESA
	35 × 20	2.30	0.30	LKS1H392MESB
	20 × 50	2.55	0.30	LKS1H472MESY
4700	22 × 40	2.55	0.30	LKS1H472MESZ
	30 × 25	2.55	0.30	LKS1H472MESB
	22 × 45	2.80	0.30	LKS1H562MESZ
5600	25 × 35	2.80	0.30	LKS1H562MESA
	30 × 30	2.80	0.30	LKS1H562MESB
	25 × 45	3.15	0.30	LKS1H682MESA
6800	30 × 35	3.15	0.30	LKS1H682MESB
	35 × 25	3.15	0.30	LKS1H682MESB
	30 × 40	3.45	0.30	LKS1H822MESB
8200	35 × 30	3.45	0.30	LKS1H822MESB
	30 × 45	3.85	0.30	LKS1H103MESB
10000	35 × 35	3.85	0.30	LKS1H103MESB
	30 × 50	4.20	0.30	LKS1H123MESB
12000	35 × 40	4.20	0.30	LKS1H123MESB
	35 × 45	4.55	0.30	LKS1H153MESB
15000	35 × 50	4.90	0.30	LKS1H183MESB

Rated ripple current (Arms) at 85°C 120 Hz



# ALUMINUM ELECTROLYTIC CAPACITORS



## LKS

■ Dimensions

56V (N2)				
Cap. (μF)	Size φD × L (mm)	Rated ripple (Arms)	tan δ	Code
1200	22 × 20	1.45	0.30	LKSN2122MESZ
1500	20 × 25	1.60	0.30	LKSN2152MESY
	25 × 20	1.60	0.30	LKSN2152MESA
1800	22 × 25	1.70	0.30	LKSN2182MESZ
2200	20 × 30	1.85	0.30	LKSN2222MESY
	30 × 20	1.85	0.30	LKSN2222MESB
2700	20 × 35	2.10	0.30	LKSN2272MESY
	22 × 30	2.10	0.30	LKSN2272MESZ
	25 × 25	2.10	0.30	LKSN2272MESA
3300	20 × 40	2.35	0.30	LKSN2332MESY
	22 × 35	2.35	0.30	LKSN2332MESZ
	25 × 30	2.35	0.30	LKSN2332MESA
	35 × 20	2.35	0.30	LKSN2332MESC
3900	20 × 50	2.60	0.30	LKSN2392MESY
	22 × 40	2.60	0.30	LKSN2392MESZ
	25 × 35	2.60	0.30	LKSN2392MESA
	30 × 25	2.60	0.30	LKSN2392MESB
4700	22 × 45	2.90	0.30	LKSN2472MESZ
	30 × 30	2.90	0.30	LKSN2472MESB
5600	22 × 50	3.20	0.30	LKSN2562MESZ
	25 × 40	3.20	0.30	LKSN2562MESA
	30 × 35	3.20	0.30	LKSN2562MESB
	35 × 25	3.20	0.30	LKSN2562MESC
6800	25 × 50	3.50	0.30	LKSN2682MESA
	30 × 40	3.50	0.30	LKSN2682MESB
	35 × 30	3.50	0.30	LKSN2682MESC
8200	30 × 45	3.80	0.30	LKSN2822MESB
	35 × 35	3.80	0.30	LKSN2822MESC
10000	30 × 50	4.15	0.30	LKSN2103MESB
	35 × 40	4.15	0.30	LKSN2103MESC
12000	35 × 45	4.45	0.30	LKSN2123MESC
15000	35 × 50	4.75	0.30	LKSN2153MESC

71V (H2)				
Cap. (μF)	Size φD × L (mm)	Rated ripple (Arms)	tan δ	Code
1000	22 × 20	1.40	0.30	LKSH2102MESZ
1200	20 × 25	1.60	0.30	LKSH2122MESY
	25 × 20	1.60	0.30	LKSH2122MESA
1500	20 × 30	1.80	0.30	LKSH2152MESY
	22 × 25	1.80	0.30	LKSH2152MESZ
1800	20 × 35	2.00	0.30	LKSH2182MESY
	22 × 30	2.00	0.30	LKSH2182MESZ
	30 × 20	2.00	0.30	LKSH2182MESB
2200	20 × 40	2.25	0.30	LKSH2222MESY
	22 × 35	2.25	0.30	LKSH2222MESZ
	25 × 25	2.25	0.30	LKSH2222MESA
2700	20 × 45	2.50	0.30	LKSH2272MESY
	22 × 40	2.50	0.30	LKSH2272MESZ
	25 × 30	2.50	0.30	LKSH2272MESA
	35 × 20	2.50	0.30	LKSH2272MESC
3300	20 × 50	2.70	0.30	LKSH2332MESY
	22 × 45	2.70	0.30	LKSH2332MESZ
	25 × 35	2.70	0.30	LKSH2332MESA
3900	30 × 25	2.70	0.30	LKSH2332MESB
	22 × 50	3.05	0.30	LKSH2392MESZ
	25 × 40	3.05	0.30	LKSH2392MESA
	30 × 30	3.05	0.30	LKSH2392MESB
4700	35 × 25	3.05	0.30	LKSH2392MESC
	25 × 45	3.40	0.30	LKSH2472MESA
	30 × 35	3.40	0.30	LKSH2472MESB
5600	35 × 30	3.40	0.30	LKSH2472MESC
	25 × 50	3.75	0.30	LKSH2562MESA
	30 × 40	3.75	0.30	LKSH2562MESB
6800	30 × 45	4.05	0.30	LKSH2682MESB
	35 × 35	4.05	0.30	LKSH2682MESC
8200	30 × 50	4.35	0.30	LKSH2822MESB
	35 × 40	4.35	0.30	LKSH2822MESC
10000	35 × 45	4.60	0.30	LKSH2103MESC

63V (1J)				
Cap. (μF)	Size φD × L (mm)	Rated ripple (Arms)	tan δ	Code
1200	22 × 20	1.50	0.30	LKS1J122MESZ
1500	20 × 25	1.65	0.30	LKS1J152MESY
	25 × 20	1.65	0.30	LKS1J152MESA
1800	20 × 30	1.80	0.30	LKS1J182MESY
	22 × 25	1.80	0.30	LKS1J182MESZ
2200	30 × 20	2.00	0.30	LKS1J222MESB
	20 × 35	2.25	0.30	LKS1J272MESY
2700	22 × 30	2.25	0.30	LKS1J272MESZ
	25 × 25	2.25	0.30	LKS1J272MESA
	20 × 45	2.45	0.30	LKS1J332MESY
3300	22 × 35	2.45	0.30	LKS1J332MESZ
	25 × 30	2.45	0.30	LKS1J332MESA
	35 × 20	2.45	0.30	LKS1J332MESC
	20 × 50	2.70	0.30	LKS1J392MESY
3900	22 × 40	2.70	0.30	LKS1J392MESZ
	25 × 35	2.70	0.30	LKS1J392MESA
	30 × 25	2.70	0.30	LKS1J392MESB
	22 × 45	3.00	0.30	LKS1J472MESZ
4700	25 × 40	3.00	0.30	LKS1J472MESA
	30 × 30	3.00	0.30	LKS1J472MESB
	35 × 25	3.00	0.30	LKS1J472MESC
5600	25 × 45	3.30	0.30	LKS1J562MESA
	30 × 35	3.30	0.30	LKS1J562MESB
6800	25 × 50	3.65	0.30	LKS1J682MESA
	30 × 40	3.65	0.30	LKS1J682MESB
	35 × 30	3.65	0.30	LKS1J682MESC
8200	30 × 45	4.05	0.30	LKS1J822MESB
	35 × 35	4.05	0.30	LKS1J822MESC
10000	30 × 50	4.40	0.30	LKS1J103MESB
	35 × 40	4.40	0.30	LKS1J103MESC
12000	35 × 45	4.75	0.30	LKS1J123MESC

80V (1K)				
Cap. (μF)	Size φD × L (mm)	Rated ripple (Arms)	tan δ	Code
820	22 × 20	1.40	0.25	LKS1K821MESZ
1000	20 × 25	1.55	0.25	LKS1K102MESY
	25 × 20	1.55	0.25	LKS1K102MESA
1200	20 × 30	1.70	0.25	LKS1K122MESY
	22 × 25	1.70	0.25	LKS1K122MESZ
1500	30 × 20	1.95	0.25	LKS1K152MESB
	20 × 35	2.25	0.25	LKS1K182MESY
1800	22 × 30	2.25	0.25	LKS1K182MESZ
	25 × 25	2.25	0.25	LKS1K182MESA
	20 × 45	2.45	0.25	LKS1K222MESY
2200	22 × 35	2.45	0.25	LKS1K222MESZ
	25 × 30	2.45	0.25	LKS1K222MESA
	35 × 20	2.45	0.25	LKS1K222MESC
	20 × 50	2.70	0.25	LKS1K272MESY
2700	22 × 45	2.70	0.25	LKS1K272MESZ
	25 × 35	2.70	0.25	LKS1K272MESA
	30 × 25	2.70	0.25	LKS1K272MESB
	22 × 50	3.00	0.25	LKS1K332MESZ
3300	25 × 40	3.00	0.25	LKS1K332MESA
	30 × 30	3.00	0.25	LKS1K332MESB
	35 × 25	3.00	0.25	LKS1K332MESC
	25 × 45	3.30	0.25	LKS1K392MESA
3900	30 × 35	3.30	0.25	LKS1K392MESB
	25 × 50	3.60	0.25	LKS1K472MESA
4700	30 × 40	3.60	0.25	LKS1K472MESB
	35 × 30	3.60	0.25	LKS1K472MESC
5600	30 × 45	3.95	0.25	LKS1K562MESB
	35 × 35	3.95	0.25	LKS1K562MESC
6800	30 × 50	4.25	0.25	LKS1K682MESB
	35 × 40	4.25	0.25	LKS1K682MESC
8200	35 × 45	4.55	0.25	LKS1K822MESC
10000	35 × 50	4.70	0.25	LKS1K103MESC

Rated ripple current (Arms) at 85°C 120 Hz

CAT.8100K

## LKS

### ■ Dimensions

100V (2A)				
Cap. ( $\mu$ F)	Size $\phi$ D x L (mm)	Rated ripple (Arms)	$\tan \delta$	Code
680	20 x 25	1.60	0.25	LKS2A681MESY
	25 x 20	1.60	0.25	LKS2A681MESA
820	20 x 30	1.75	0.25	LKS2A821MESY
	22 x 25	1.75	0.25	LKS2A821MESZ
1000	20 x 35	1.95	0.25	LKS2A102MESY
	22 x 30	1.95	0.25	LKS2A102MESZ
	25 x 25	1.95	0.25	LKS2A102MESA
	30 x 20	1.95	0.25	LKS2A102MESB
1200	20 x 40	2.15	0.25	LKS2A122MESY
	22 x 35	2.15	0.25	LKS2A122MESZ
1500	20 x 45	2.45	0.25	LKS2A152MESY
	22 x 40	2.45	0.25	LKS2A152MESZ
	25 x 30	2.45	0.25	LKS2A152MESA
	30 x 25	2.45	0.25	LKS2A152MESB
	35 x 20	2.45	0.25	LKS2A152MESB
1800	20 x 50	2.70	0.25	LKS2A182MESY
	22 x 45	2.70	0.25	LKS2A182MESZ
	25 x 35	2.70	0.25	LKS2A182MESA
	30 x 30	2.70	0.25	LKS2A182MESB
2200	22 x 50	2.95	0.25	LKS2A222MESZ
	25 x 40	2.95	0.25	LKS2A222MESA
	35 x 25	2.95	0.25	LKS2A222MESB
2700	25 x 50	3.20	0.25	LKS2A272MESA
	30 x 35	3.20	0.25	LKS2A272MESB
	35 x 30	3.20	0.25	LKS2A272MESB
3300	30 x 40	3.60	0.25	LKS2A332MESB
	35 x 35	3.60	0.25	LKS2A332MESB
3900	30 x 50	4.00	0.25	LKS2A392MESB
	35 x 40	4.00	0.25	LKS2A392MESB
4700	35 x 45	4.30	0.25	LKS2A472MESB
5600	35 x 50	4.70	0.25	LKS2A562MESB

Rated ripple current (Arms) at 85°C 120 Hz

# ALUMINUM ELECTROLYTIC CAPACITORS



Snap-in Terminal Type, For Audio Equipment, of Switching Power Supplies



- In order to get high quality sound from 105°C standard series.
- Selected materials to achieve superior acoustic sound.
- Compliant to the RoHS directive (2011/65/EU,(EU)2015/863).

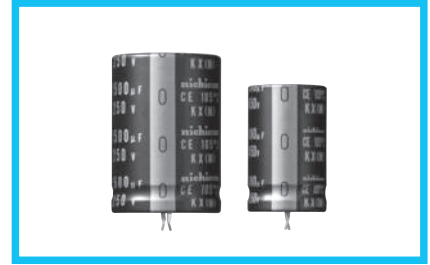

## Specifications

Item	Performance Characteristics		
Category Temperature Range	- 40 to +105°C (200 • 250V), - 25 to + 105°C (400 • 450V)		
Rated Voltage Range	200 to 450V		
Rated Capacitance Range	56 to 2200μF		
Capacitance Tolerance	±20% at 120Hz, 20°C		
Leakage Current	After 5 minutes' application of rated voltage at 20°C, leakage current is not more than $3\sqrt{CV}$ (μA), [C: Rated Capacitance(μF), V: Voltage (V)]		
Tangent of loss angle (tan δ)	See refer to next page (Measurement frequency : 120Hz at 20°C)		
Stability at Low Temperature	Rated voltage(V)	200 to 250      400 to 450	
	Impedance ratio ZT/Z20(MAX.)	Z - 25°C/Z+20°C      4      8 Z - 40°C/Z+20°C      12      —	
Endurance	The specifications listed at right shall be met when the capacitors are restored to 20°C after the rated voltage is applied for 2000 hours at 105°C.	Capacitance change	Within ±20% of the initial capacitance value
		tan δ	200% or less than the initial specified value
Shelf Life	After storing the capacitors under no load at 105°C for 1000 hours and then performing voltage treatment based on JIS C 5101-4 clause 4.1 at 20°C, they shall meet the specified values for the endurance characteristics listed at right.	Capacitance change	Within ±15% of the initial capacitance value
		tan δ	150% or less than the initial specified value
Marking	Printed with gold color letter on black sleeve.		

## Drawing

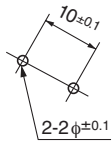
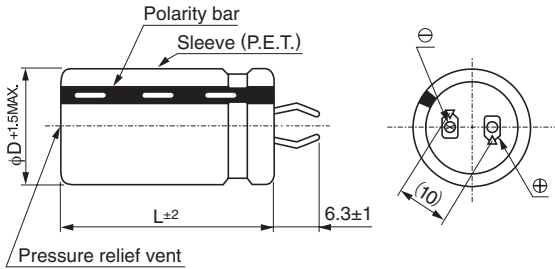

(PC board hole dimensions)

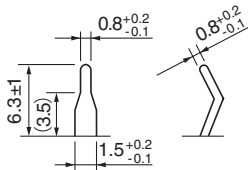

(Terminal dimensions)

## Type numbering system (Example : 400 V 120μF , Dia.φ25)

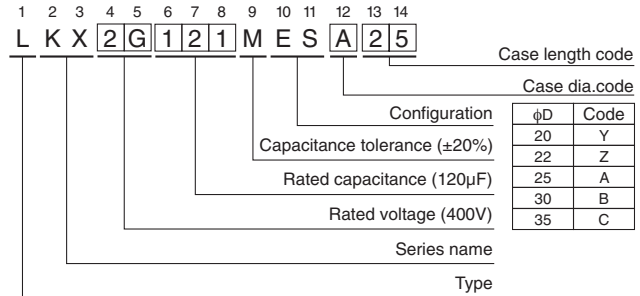

## Frequency coefficient of rated ripple current

Frequency (Hz)	50	60	120	300	1k	10k	50k or more
200 to 250V	0.81	0.85	1.00	1.17	1.32	1.45	1.50
400 to 450V	0.77	0.82	1.00	1.16	1.30	1.41	1.43

● Dimension table in next page.



■ Dimensions

200V (2D)				
Cap. (μF)	Size φD × L(mm)	Rated ripple (Arms)	tan δ	Code
220	20 × 25	0.90	0.15	LKX2D221MESY25
270	20 × 30	0.99	0.15	LKX2D271MESY30
	22 × 25	0.99	0.15	LKX2D271MESZ25
330	20 × 35	1.20	0.15	LKX2D331MESY35
390	20 × 40	1.31	0.15	LKX2D391MESY40
	22 × 30	1.31	0.15	LKX2D391MESZ30
	25 × 25	1.31	0.15	LKX2D391MESA25
470	20 × 45	1.48	0.15	LKX2D471MESY45
	22 × 35	1.48	0.15	LKX2D471MESZ35
	25 × 30	1.48	0.15	LKX2D471MESA30
560	20 × 50	1.60	0.15	LKX2D561MESY50
	22 × 40	1.60	0.15	LKX2D561MESZ40
	25 × 35	1.60	0.15	LKX2D561MESA35
680	22 × 45	1.75	0.15	LKX2D681MESZ45
	25 × 40	1.75	0.15	LKX2D681MESA40
	30 × 30	1.75	0.15	LKX2D681MESB30
	35 × 25	1.75	0.15	LKX2D681MESC25
820	25 × 45	2.04	0.15	LKX2D821MESA45
	30 × 35	2.04	0.15	LKX2D821MESB35
1000	25 × 50	2.30	0.15	LKX2D102MESA50
	30 × 40	2.30	0.15	LKX2D102MESB40
	35 × 30	2.30	0.15	LKX2D102MESC30
1200	30 × 45	2.65	0.15	LKX2D122MESB45
	35 × 35	2.65	0.15	LKX2D122MESC35
1500	30 × 50	2.80	0.15	LKX2D152MESB50
	35 × 40	2.80	0.15	LKX2D152MESC40
1800	35 × 45	3.08	0.15	LKX2D182MESC45
2200	35 × 50	3.48	0.15	LKX2D222MESC50

250V (2E)				
Cap. (μF)	Size φD × L(mm)	Rated ripple (Arms)	tan δ	Code
180	20 × 25	0.90	0.15	LKX2E181MESY25
220	20 × 30	1.00	0.15	LKX2E221MESY30
	22 × 25	1.00	0.15	LKX2E221MESZ25
270	20 × 35	1.10	0.15	LKX2E271MESY35
	22 × 30	1.10	0.15	LKX2E271MESZ30
330	20 × 40	1.20	0.15	LKX2E331MESY40
	22 × 35	1.20	0.15	LKX2E331MESZ35
	25 × 25	1.20	0.15	LKX2E331MESA25
390	20 × 45	1.30	0.15	LKX2E391MESY45
	22 × 40	1.30	0.15	LKX2E391MESZ40
	25 × 30	1.30	0.15	LKX2E391MESA30
470	20 × 50	1.40	0.15	LKX2E471MESY50
	22 × 45	1.40	0.15	LKX2E471MESZ45
	25 × 35	1.40	0.15	LKX2E471MESA35
	30 × 25	1.40	0.15	LKX2E471MESB25
560	22 × 50	1.50	0.15	LKX2E561MESZ50
	25 × 40	1.50	0.15	LKX2E561MESA40
	30 × 30	1.50	0.15	LKX2E561MESB30
	35 × 25	1.50	0.15	LKX2E561MESC25
680	25 × 50	1.70	0.15	LKX2E681MESA50
	30 × 35	1.70	0.15	LKX2E681MESB35
820	30 × 40	2.00	0.15	LKX2E821MESB40
	35 × 30	2.00	0.15	LKX2E821MESC30
1000	30 × 45	2.20	0.15	LKX2E102MESB45
	35 × 35	2.20	0.15	LKX2E102MESC35
1200	35 × 40	2.30	0.15	LKX2E122MESC40
1500	35 × 50	2.50	0.15	LKX2E152MESC50

400V (2G)				
Cap. (μF)	Size φD × L(mm)	Rated ripple (Arms)	tan δ	Code
68	20 × 25	0.49	0.15	LKX2G680MESY25
82	20 × 30	0.64	0.15	LKX2G820MESY30
	22 × 25	0.64	0.15	LKX2G820MESZ25
100	20 × 35	0.68	0.15	LKX2G101MESY35
120	20 × 35	0.73	0.15	LKX2G121MESY35
	22 × 30	0.73	0.15	LKX2G121MESZ30
	25 × 25	0.73	0.15	LKX2G121MESA25
150	20 × 45	0.85	0.15	LKX2G151MESY45
	22 × 35	0.85	0.15	LKX2G151MESZ35
	25 × 30	0.85	0.15	LKX2G151MESA30
180	20 × 50	0.95	0.15	LKX2G181MESY50
	22 × 40	0.95	0.15	LKX2G181MESZ40
	25 × 35	0.95	0.15	LKX2G181MESA35
220	22 × 50	1.10	0.15	LKX2G221MESZ50
	25 × 40	1.10	0.15	LKX2G221MESA40
	30 × 30	1.10	0.15	LKX2G221MESB30
	35 × 25	1.10	0.15	LKX2G221MESC25
270	25 × 45	1.22	0.15	LKX2G271MESA45
	30 × 35	1.22	0.15	LKX2G271MESB35
330	25 × 50	1.44	0.15	LKX2G331MESA50
	30 × 40	1.44	0.15	LKX2G331MESB40
	35 × 30	1.44	0.15	LKX2G331MESC30
390	30 × 45	1.55	0.15	LKX2G391MESB45
	35 × 35	1.55	0.15	LKX2G391MESC35
470	30 × 50	1.68	0.15	LKX2G471MESB50
	35 × 40	1.68	0.15	LKX2G471MESC40
560	35 × 45	1.90	0.15	LKX2G561MESC45
680	35 × 50	2.12	0.15	LKX2G681MESC50

450V (2W)				
Cap. (μF)	Size φD × L(mm)	Rated ripple (Arms)	tan δ	Code
56	20 × 25	0.44	0.20	LKX2W560MESY25
68	20 × 30	0.50	0.20	LKX2W680MESY30
82	20 × 35	0.64	0.20	LKX2W820MESY35
	22 × 30	0.64	0.20	LKX2W820MESZ30
100	20 × 40	0.69	0.20	LKX2W101MESY40
	22 × 30	0.69	0.20	LKX2W101MESZ30
	25 × 25	0.69	0.20	LKX2W101MESA25
120	20 × 45	0.72	0.20	LKX2W121MESY45
	22 × 35	0.72	0.20	LKX2W121MESZ35
	25 × 30	0.72	0.20	LKX2W121MESA30
150	22 × 45	0.79	0.20	LKX2W151MESZ45
	25 × 35	0.79	0.20	LKX2W151MESA35
	30 × 25	0.79	0.20	LKX2W151MESB25
180	22 × 50	0.87	0.20	LKX2W181MESZ50
	25 × 40	0.87	0.20	LKX2W181MESA40
	30 × 30	0.87	0.20	LKX2W181MESB30
	35 × 25	0.87	0.20	LKX2W181MESC25
220	25 × 45	1.05	0.20	LKX2W221MESA45
	30 × 35	1.05	0.20	LKX2W221MESB35
270	30 × 40	1.23	0.20	LKX2W271MESB40
	35 × 30	1.23	0.20	LKX2W271MESC30
330	30 × 45	1.38	0.20	LKX2W331MESB45
	35 × 35	1.38	0.20	LKX2W331MESC35
390	35 × 40	1.61	0.20	LKX2W391MESC40
470	35 × 45	1.78	0.20	LKX2W471MESC45
560	35 × 50	1.99	0.20	LKX2W561MESC50

Rated ripple current (Arms) at 105°C 120Hz