

32-bit, 768 kHz Sampling Stereo Audio D/A Converter

BD34301EKV Evaluation Board

(BD34301EKV-EVK-003)

IC Introduction

BD34301EKV is a 32-bit Stereo Audio D/A Converter with ROHM original sound quality design, realizing excellent performance (SNR: 130 dB (Typ), THD+N: -115 dB (Typ))^{*1} suitable for high-end audio. Different type sound is realized by selecting 2 kinds of digital FIR filters (Sharp Roll-Off, Slow Roll-Off). PCM I/F supports up to 768 kHz and DSD I/F supports up to 22.4 MHz.

^{*1} BD34301EKV-EVK is tuned for listening evaluation. Electrical performance, External CR values are different from BD34301EKV Datasheet. (SNR: 125 dB (Typ) at Balance Output)

BD34301EKV Block Diagram

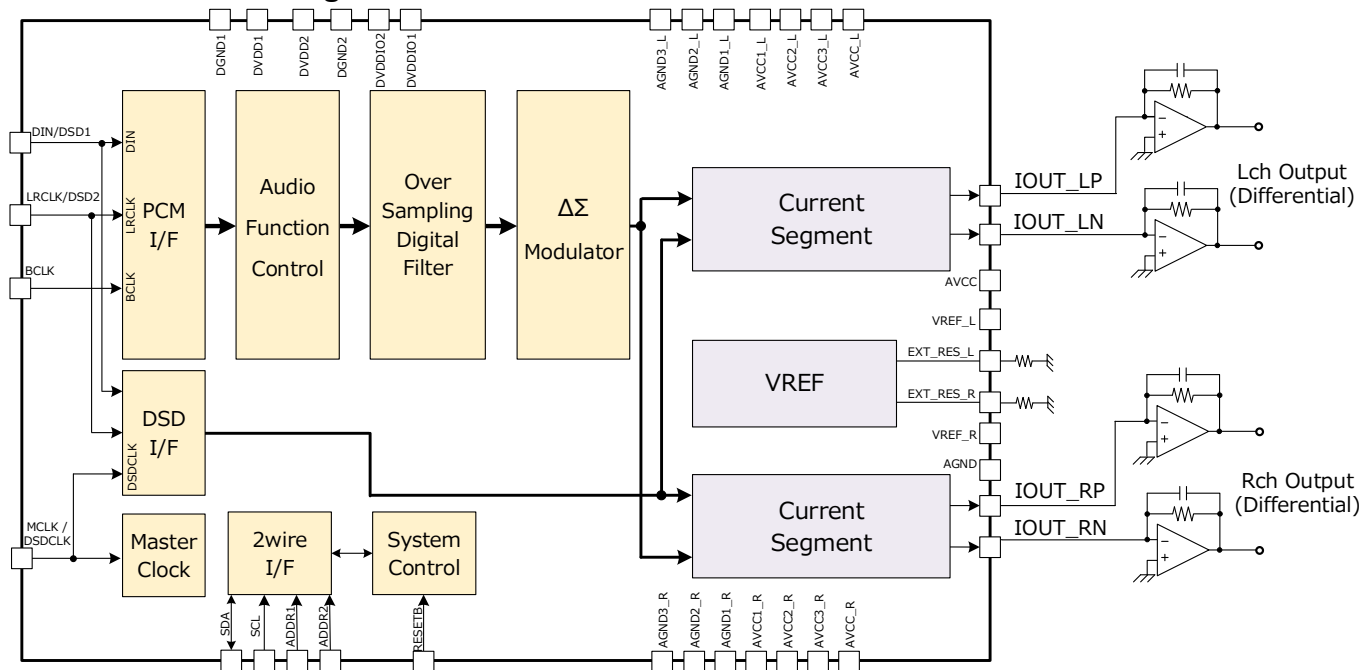

Recommended Operating Conditions

Item	Symbol	Ratings	Unit
Power Supply Voltage	AVCC ^{*1}	4.5 to 5.5	V
	DVDDIO	3.0 to 3.6	
	DVDD	1.4 to 1.6	
Operating Temperature	Topr	-25 to +85	°C

^{*1} AVCC, AVCC_R, AVCC_L in Block Diagram.

Package

HTQFP64BV (64 pin, 0.5 mm pitch)

W(Typ) D(Typ) H(Max)
12.0 mm x 12.0 mm x 1.00 mm

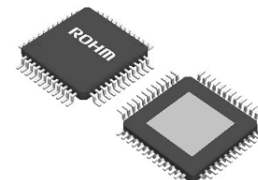

Evaluation Board Block Diagram

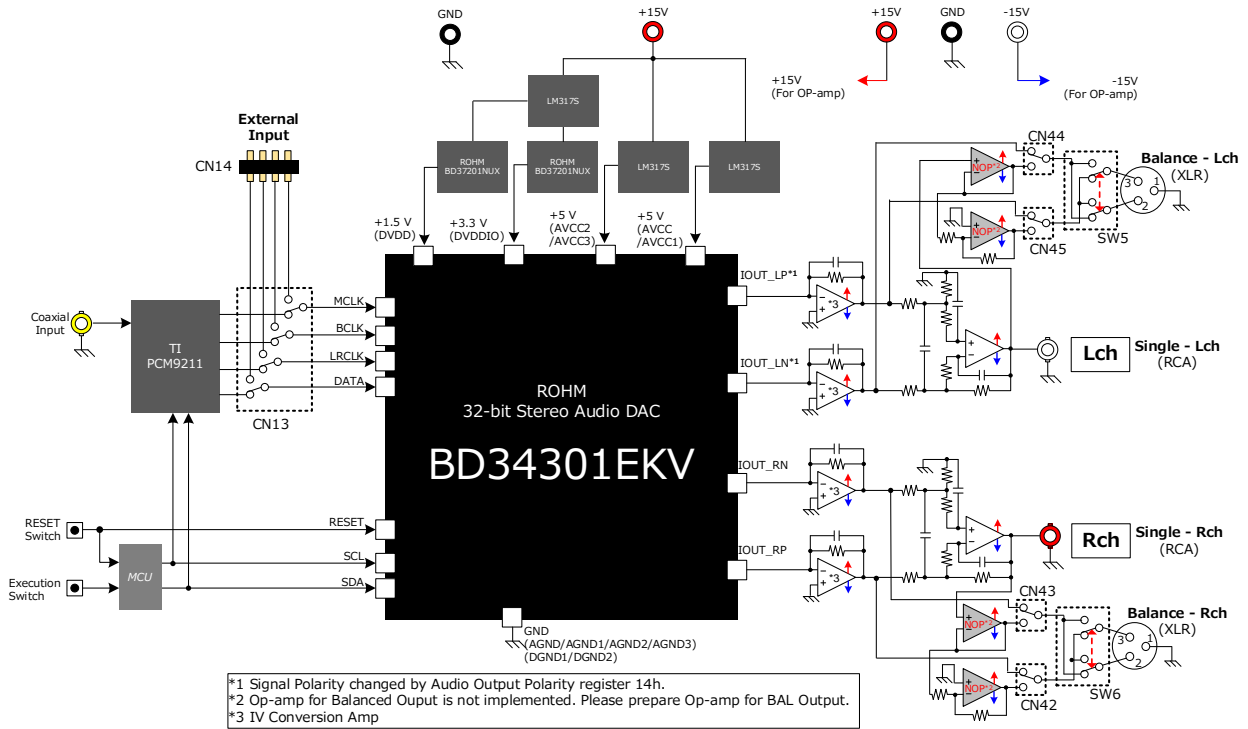

Evaluation Board

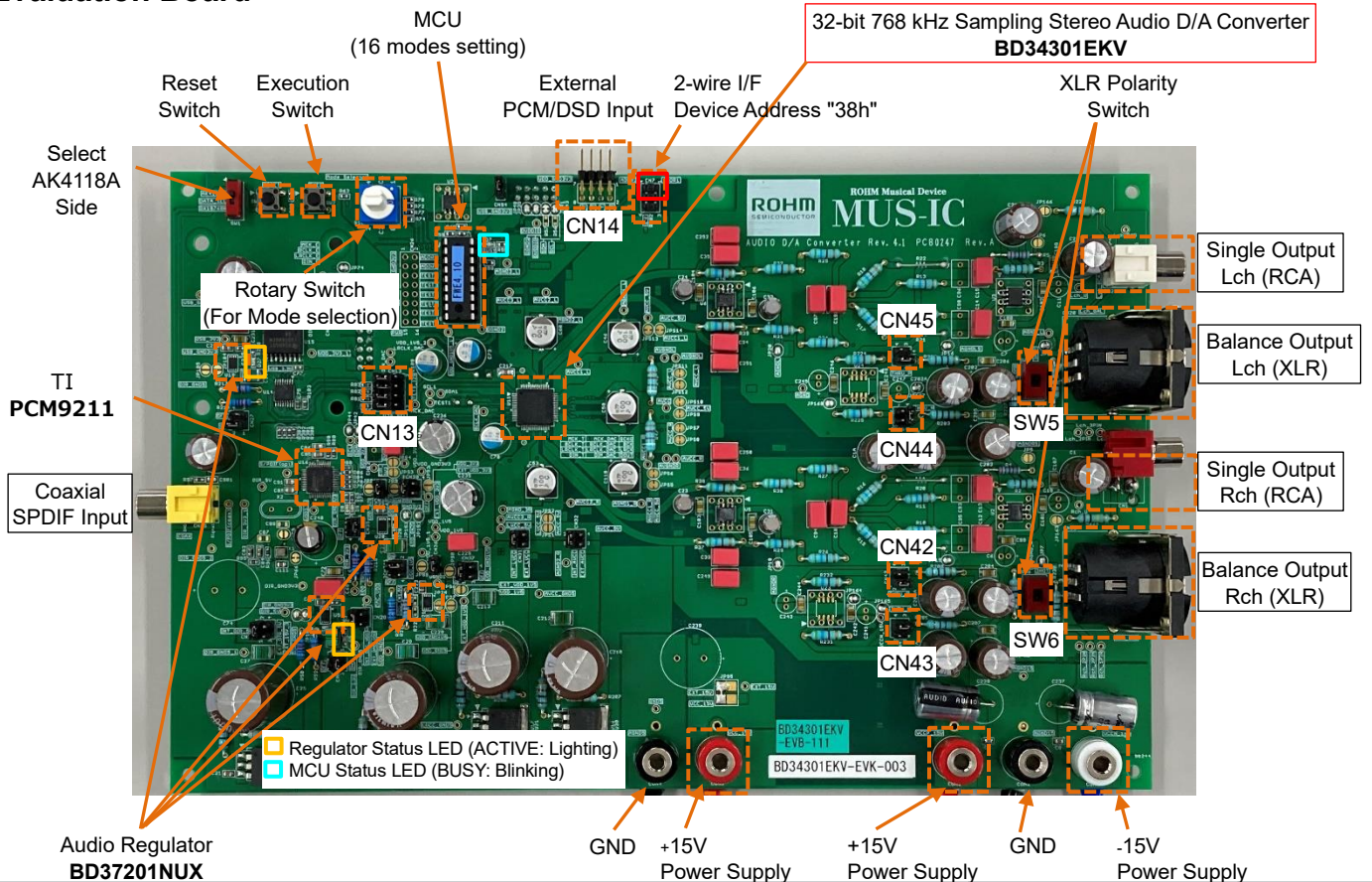

Hardware Setup (Proceed set-up procedure from "A" to "G" in sequence)

- 1) Connect "+15V Power Supply" to "A".
- 2) Connect "±15V Power Supply" to "B".
- 3) Connect "Coaxial SPDIF Input" to "C".
- 4) Connect "Single Output" or "Balance Output" to "D".

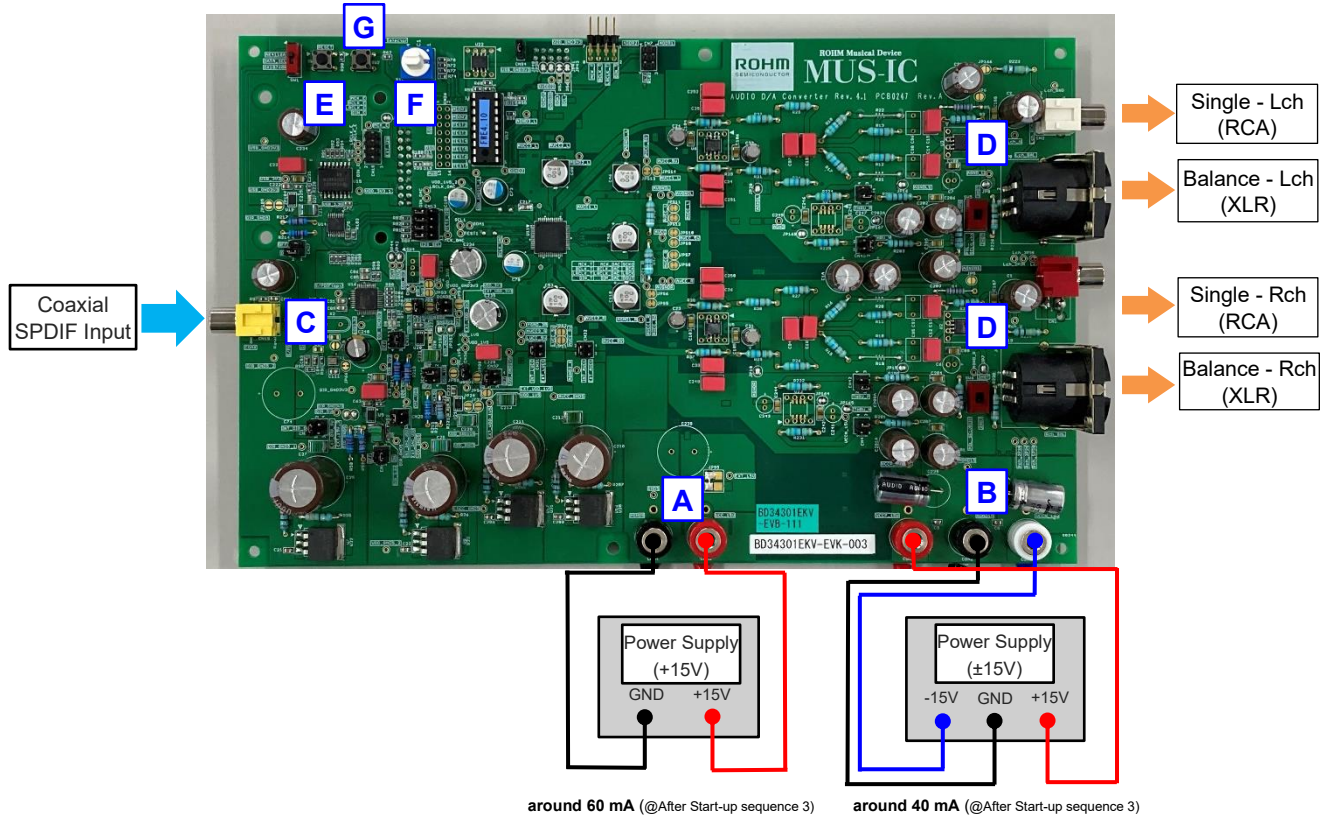

Start-up/Shutdown Procedure

Start-up Procedure

- 1) Power Amplifier connecting Evaluation Board Output set to "Mute ON".
- 2) Set "+15V Power Supply" turn "ON".
- 3) Set "±15V Power Supply" turn "ON".
- 4) Push Reset switch "E".
- 5) Turn the Rotary Switch "F" to select Mode.
- 6) Push Execution Switch "G".
- 7) MCU status indicator LED will blink during BUSY. Wait for LED to turn off.
- 8) Power Amplifier connecting Evaluation Board Output set to "Mute OFF".
- 9) Start playback.

Shutdown Procedure

- 1) Stop playback.
- 2) Power Amplifier connecting Evaluation Board Output set to "Mute ON"
- 3) Set "±15V Power supply" turn "OFF".
- 4) Set "+15V Power supply" turn "OFF".

Mode Selection

There are 16 Modes selectable on BD34301EKV Evaluation Board, as listed in the following table:

It is possible to select each mode by Rotary Switch.

Mode No. of Rotary Switch	Format	Filter Type	Input	MCLK	FIR Filter ^{*4}		Over Sampling Rate						Sampling Frequency fs [kHz]							
					FirAlgo [3:0]	FirCoef [2:0]	X8	X16	x32	x64	x128	x256	44.1 / 48	88.2 / 96	176.4 / 192	352.8 / 384	705.6 / 768			
Mode 0 ^{*1}	PCM (I ² S)	Sharp1	Coaxial SPDIF	512 x fs	1h	0h				O			O							
Mode 1 ^{*1}				256 x fs	2h	1h				O				O						
Mode 2 ^{*1}				128 x fs	4h	2h				O					O					
Mode 3 ^{*1}			External PCM (I ² S)	22.579 MHz (fs=705.6 k) 24.576 MHz (fs=768 k)	8h	0h	O											O		
Mode 4		Not Available																		
Mode 5 ^{*2}		Sharp2	Coaxial SPDIF		512 x fs	1h	0h					O	O							
Mode 6 ^{*2}					256 x fs	2h	1h				O				O					
Mode 7 ^{*2}					128 x fs	4h	2h				O					O				
Mode 8 ^{*2,3}					512 x fs	1h	3h						O	O						
Mode 9 ^{*2}			Slow		256 x fs	2h	4h				O			O						
Mode A ^{*2}					128 x fs	4h	5h				O					O				
Mode B ^{*2}			-	External PCM (I ² S)	22.579 MHz (fs=352.8 k, 705.6 k) 24.576 MHz (fs=384 k, 768 k)	8h	0h												O	
Mode C ^{*2}						8h	0h													
Mode D ^{*2}		DSD	-	External DSD	-	0h	0h	DSD Filter ^{*5}	02	Input Signal: DSD64(2.8M), DSD128(5.6M)										
Mode E ^{*2}						0h	0h		01	Input Signal: DSD256(11.2M)										
Mode F ^{*2}						0h	0h		00	Input Signal: DSD512(22.4M)										

*1 Mode 0 to 3 are Electrical Characteristics in BD34301EKV Datasheet.
 *2 Mode 5 to F are Recommended Settings in BD34301EKV Datasheet.
 *3 Although Recommended setting is HpcMode = 1, only Mode 8 uses HpcMode = 0.
 *4 Refer to BD34301EKV Datasheet P28 [18. Address 30h, 31h (FIR Filter 1, FIR Filter 2)]
 *5 Refer to BD34301EKV Datasheet P23 [11. Address 16h (DSD Filter)]

Mode Setting

- 1) Push Reset Switch.
- 2) Turn the Rotary Switch to select Mode.
- 3) Push Execution Switch.

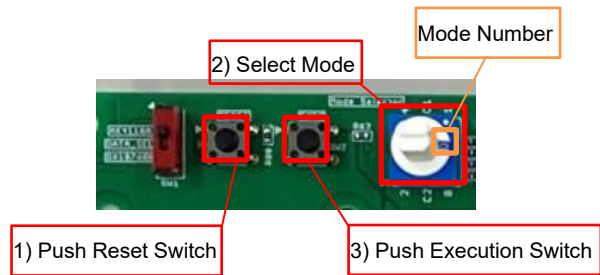

Mode Change

- 1) Set to Mute the Power Amplifier connecting Evaluation Board Output to avoid pop-noise when changing Mode in the Rotary Switch.
- 2) Do not stop input to "MCLK" when changing Mode, while selecting the "External PCM or DSD" input.

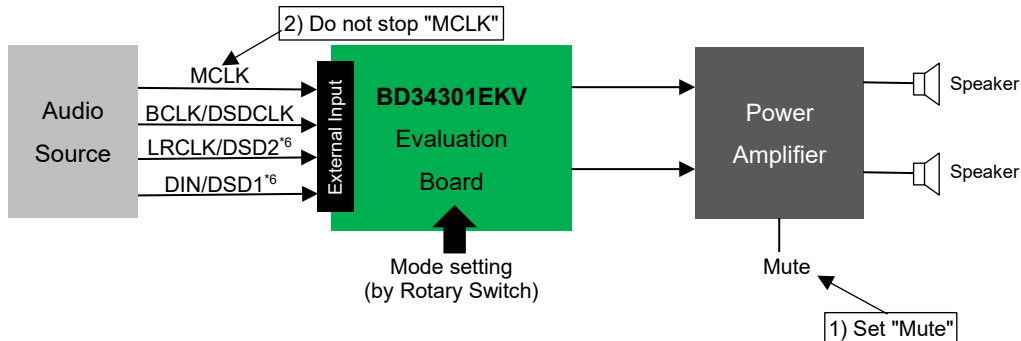

*6 DSD1 and DSD2 are swapped because Register 13h sets to 1h on this board.

Input Terminal

Coaxial SPDIF Input

Connect between BD34301EKV(Center) and "INT_I2S"(Left side) by using 4 Jumper Pins.

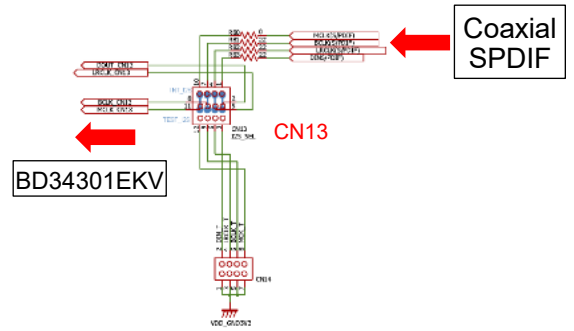
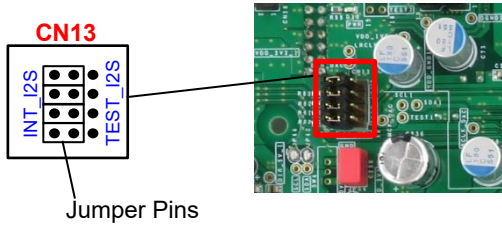

External PCM(I²S) /DSD Input

Connect between BD34301EKV(Center) and "TEST_I2S"(Right side) by using 4 Jumper Pins.

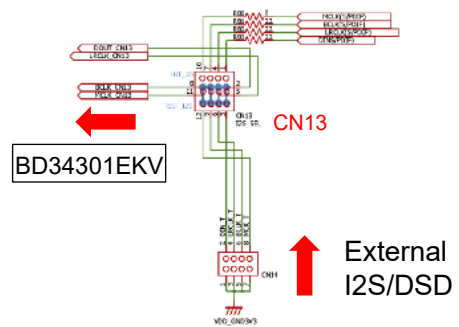
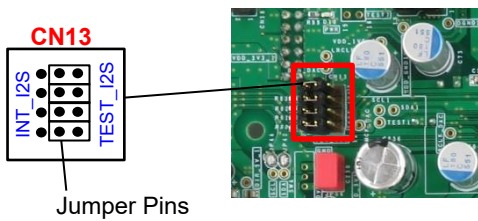

When using External Input, Pin assignments are as follows.

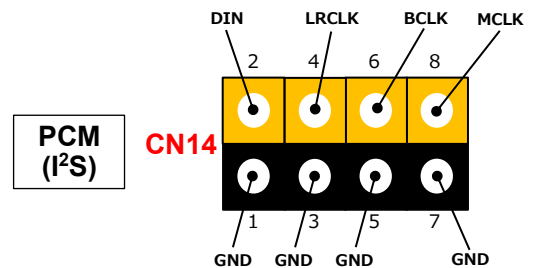
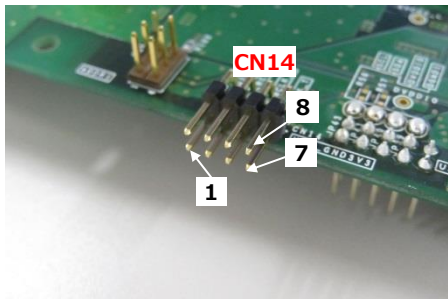

*1 "DSDCLK" should be input to both the 6pin and 8pin of CN14.

*2 DSD1 and DSD2 are swapped because Register 13h sets to 1h on this board.

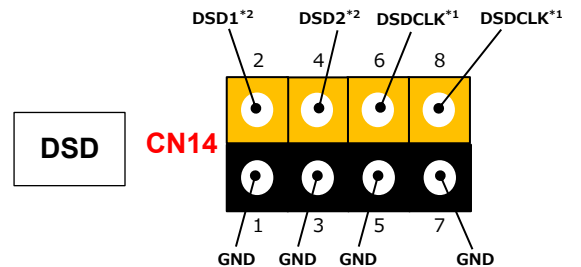

Output Terminal

UNBAL(RCA) - (default)

The sound quality is tuned using this pin for this EVK.

BAL(THRU-XLR)^{*1} - (Direct Output from IV Conversion Amp^{*2})

Connect Jumper Pins to "THRU_P" side at CN42, CN44.

Connect Jumper Pins to "THRU_N" side at CN43, CN45.

The Polarity of XLR (Hot/Cold) can be switched by SW5, SW6.

^{*1} This terminal is direct output from IV Conversion Amp.

^{*2} Refer to Page 2, Evaluation Board Block Diagram.

XLR Output Polarity	Switch Position	
	SW5(Lch)	SW6(Rch)
2-HOT, 3-COLD	"3-HOT" ^{*3}	"2-HOT"
2-COLD, 3-HOT	"2-HOT"	"3-HOT"

^{*3} Polarity inverted by register 14h.

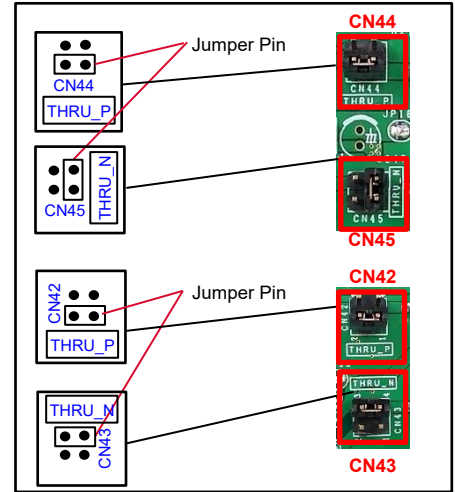

Jumper Pin Setting for BAL(THRU-XLR)

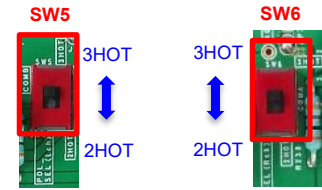

Polarity Switch for XLR Output

BAL(Op-amp-XLR) - (Additional Op-amp needed)^{*4}

Connect Jumper Pins to "NOT THRU_P" side at CN42, CN44.

Connect Jumper Pins to "NOT THRU_N" side at CN43, CN45.

The Polarity of XLR Hot/Cold can be switched by SW5, SW6.

^{*4} Op-amp for XLR Output is not implemented. Implement prepared Op-amp to U23 and U24.
Operation confirmed: NE5532, OPA2134

XLR Output Polarity	Switch Position	
	SW5(Lch)	SW6(Rch)
2-HOT, 3-COLD	"2-HOT"	"2-HOT"
2-COLD, 3-HOT	"3-HOT"	"3-HOT"

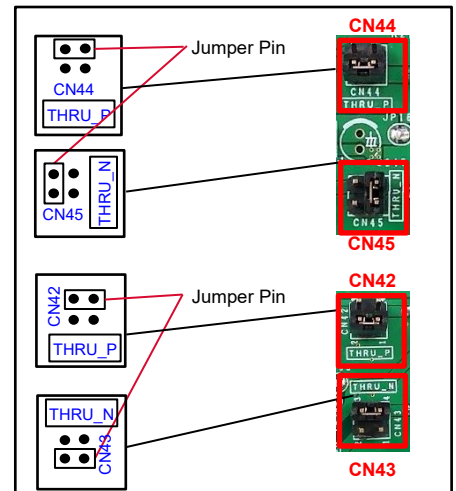

Jumper Pin setting for BAL(Op-amp-XLR)



U23



U24

Op-amp placement for BAL(Op-amp-XLR)

Evaluation Board Schematic

Click inside Circuit Diagram area to open high resolution Circuit Diagram.

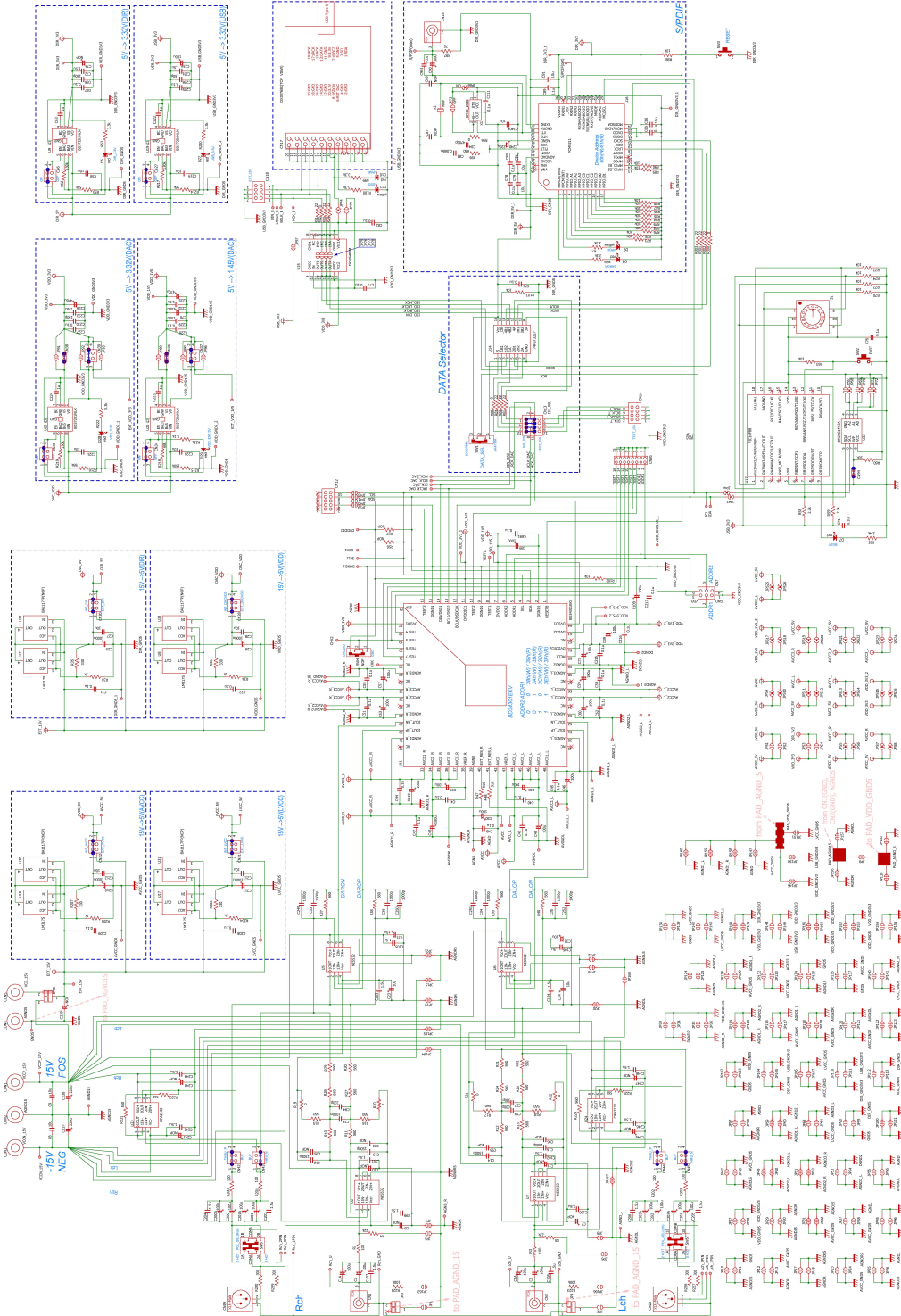

PCB Patterns

Top Silkscreen Overlay

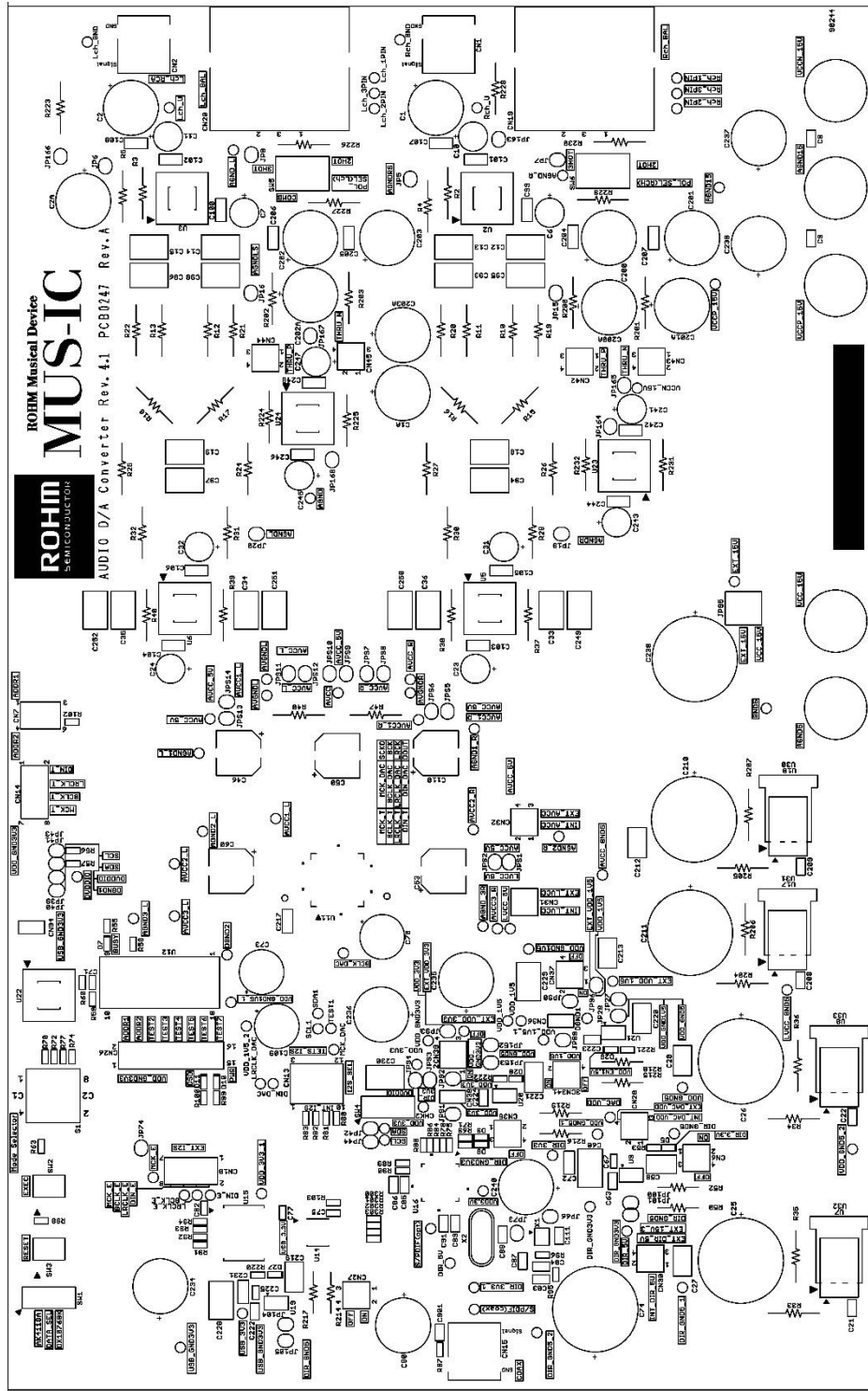

Bottom Silkscreen Overlay

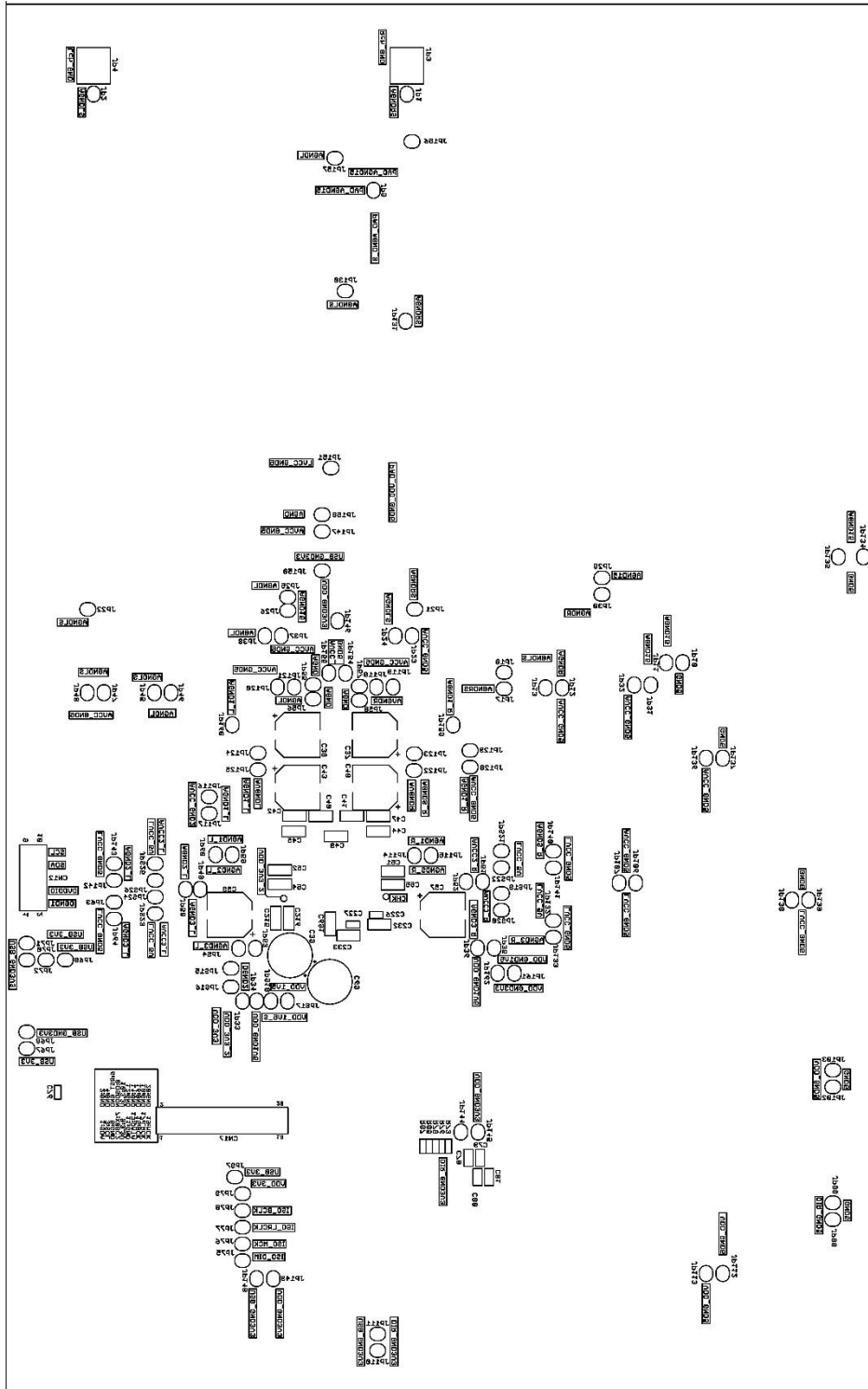

TOP Layer

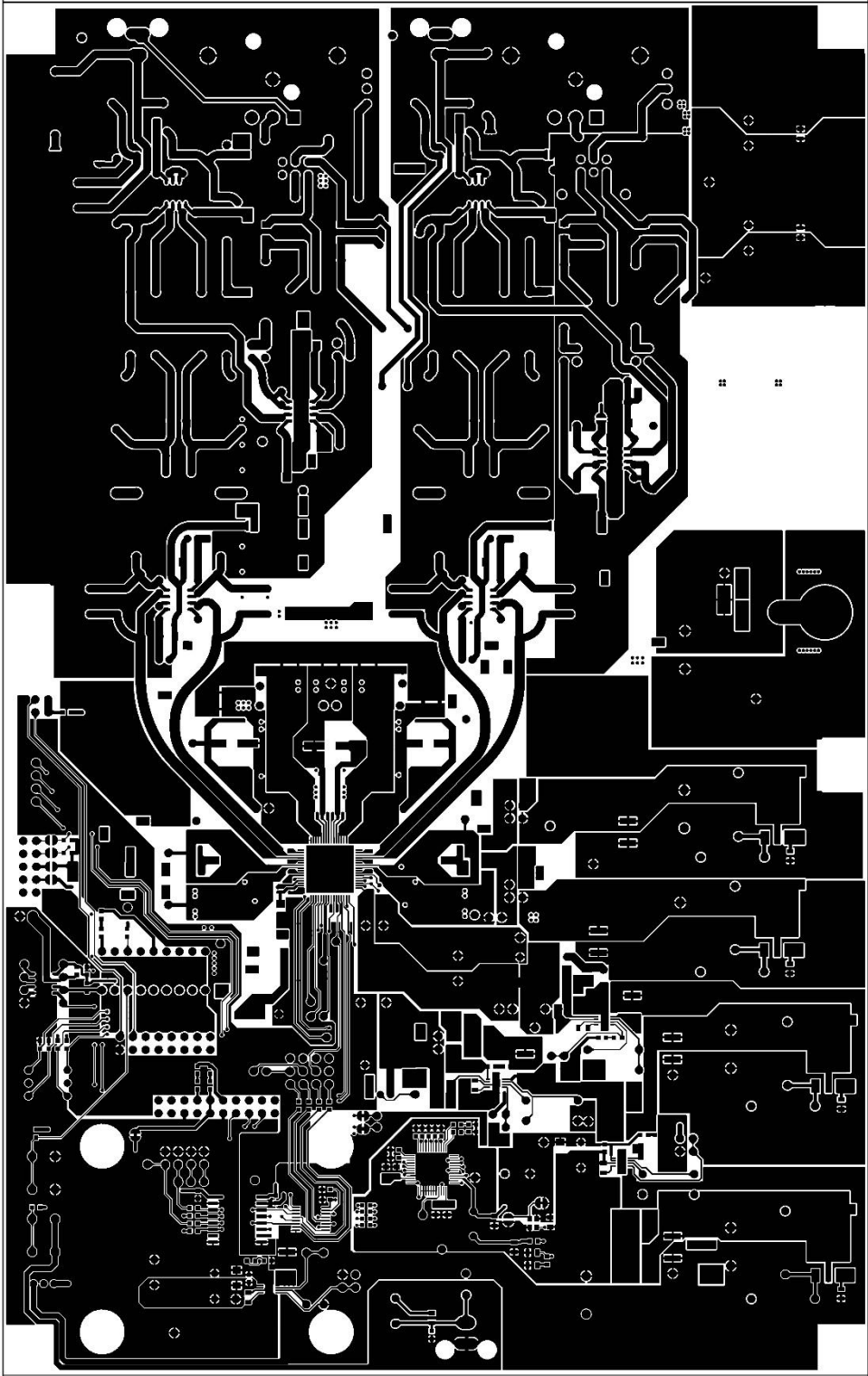

M1 Layer

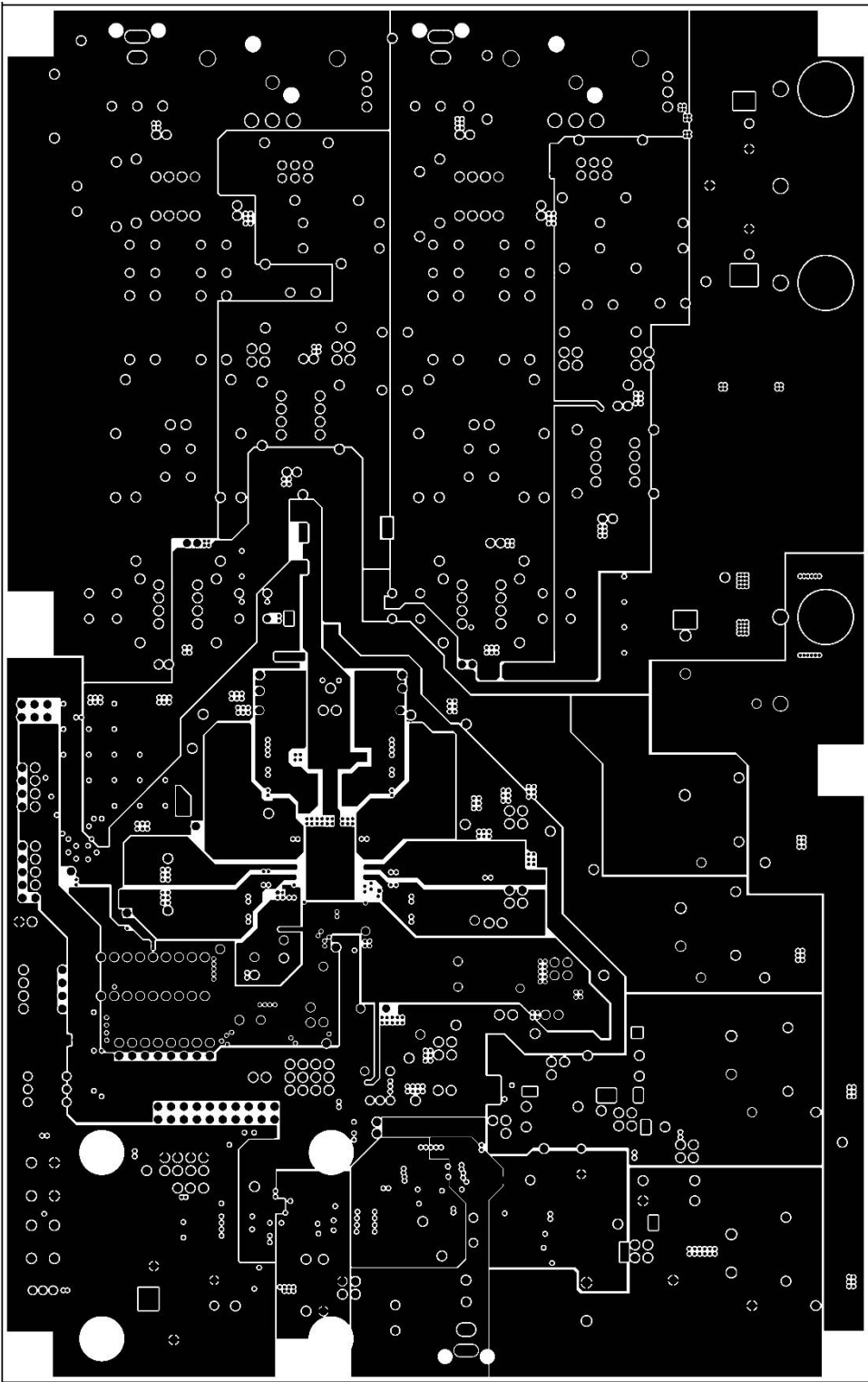

M2 Layer

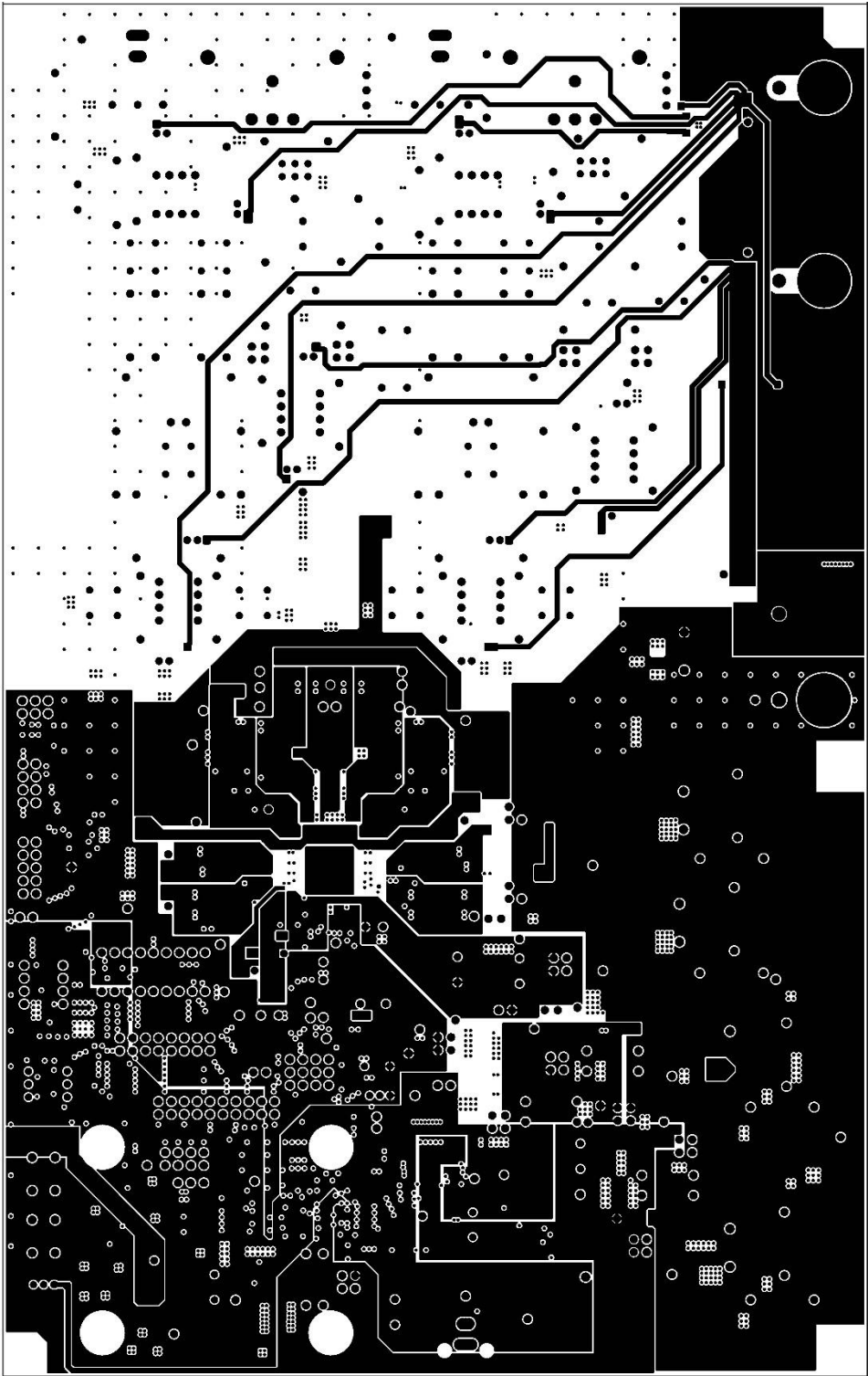

Bottom Layer

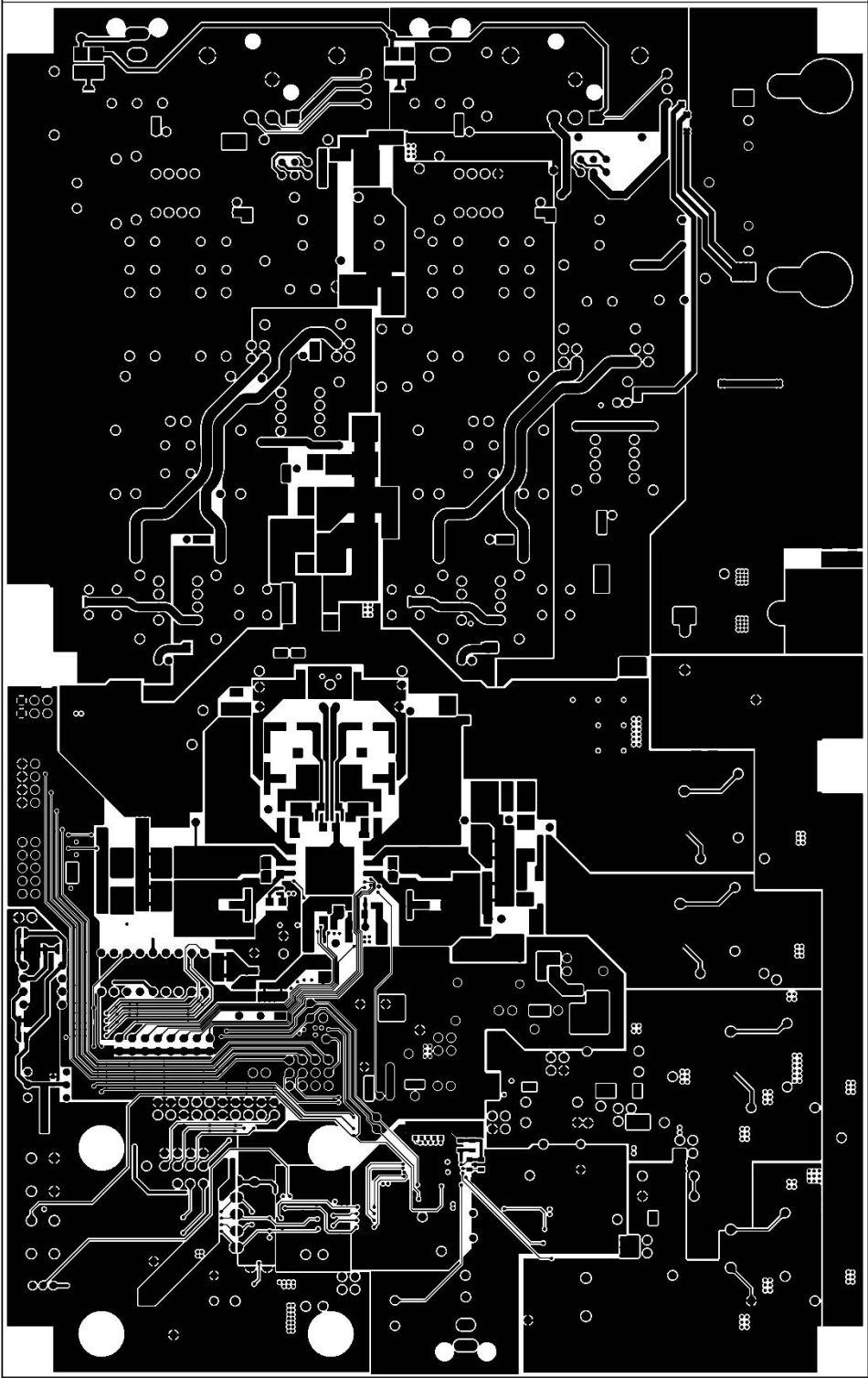

Bill of Materials

	Quantity	Type	Component No.	Manufacturer	Product No.
Capacitor	1	0.068 μ F	C83	Murata	GRM188R71E683KA01D
	9	0.1 μ F	C67,C71,C75,C76,C77,C82, C225,C226,C227	Murata	GCM188L81H104KA57D
	25	0.1 μ F	C21,C22,C40,C41,C42,C44,C45,C47, C49,C51,C52,C54,C55,C78,C80,C85, C89,C111,C208,C209,C215,C216, C217,C691,C901	Murata	GRM21BB11H104KA01L
	22	1.5 μ F	C72,C99,C100,C101,C102,C103, C104,C105,C106,C107,C108,C204, C205,C206,C207,C231,C232,C233, C242,C244,C246,C248	Rubycon	16MU155MA23216
	6	1000 pF	C18,C19,C249,C250,C251,C252	WIMA	FKP2D011001D00
	4	1000 μ F	C25,C26,C210,C211	ELNA	RFS-16V102M17#5
	14	100 μ F	C1,C1A,C2,C2A,C90,C200,C200A, C201,C201A,C202,C202A,C203, C203A,C234	ELNA	RFS-16V101MH3#5
	2	470 μ F	C235,C236	Toshin Kogyo	1CUTSJ471M0
	2	220 μ F	C237,C238	Toshin Kogyo	1HUTSJ221M0
	11	100 μ F	C37,C38,C43,C46,C48,C50,C53, C57,C59,C60,C110	Nippon Chemi-con	EMAR160ADA101MH63G
	4	10 μ F	C23,C24,C31,C32	ELNA	RFS-35V100ME3#5
	6	10 μ F	C8,C9,C79,C81,C86,C91	Murata	GRM21BR61E106KA73
	9	10 μ F	C27,C28,C58,C212,C213,C219, C220,C221,C240A	Rubycon	16MU106MC44532
	8	1500 pF	C12,C13,C14,C15,C33,C34,C35,C36	WIMA	FKP2D011501D00
	4	150 pF	C68,C228,C229,C230	WIMA	FKP2D001501D00
	5	100 μ F	C39,C69,C70,C73,C109	Nichicon	PLF1C101MDL4TD
	4	1 μ F	C63,C222,C223,C224	Murata	GRM21BB31E105KA98L
	1	220 μ F	C240	ELNA	RFS-16V221MH5#5
2	330 pF	C94,C97	WIMA	FKP2D003301D00	
1	4700 pF	C84	Murata	GRM188R71E472KA01D	
Connector	1	COAX JACK	CN1	SMK	LPR6520-0802
	1	COAX JACK	CN2	SMK	LPR6520-0803
	1	COAX JACK	CN15	SMK	LPR6520-0804
	2	XLR-M	CN19,CN20	Switchcraft	POG3MRA112
	2	Terminal(Black)	CON2,CON4	Sato Parts	TJ-563-B
	2	Terminal(Red)	CON1,CON5	Sato Parts	TJ-563-R
LED	1	Terminal(White)	CON3	Sato Parts	TJ-563-W
	6	Red	D5,D7,D8,D10,D27	ROHM	SML-E12V8WT86P
	3	Yellow	D9,D11	ROHM	SML-E12Y8WT86
Resistor	4	0 Ω	R80,R92,R96,R300	KOA	RK73Z1JTTD
	9	22 Ω	R81,R82,R83,R91,R93,R94,R301, R302,R303	KOA	RK73B1JTTD220J
	1	75 Ω	R97	KOA	RK73B1JTTD750J
	6	100 Ω	R2,R3,R200,R201,R202,R203	Am transformer	AMRT 1/2W 100 Ω
	24	560 Ω	R10,R11,R12,R13,R15,R16,R17, R18,R24,R25,R26,R27,R29,R30, R31,R32,R37,R38,R39,R40,R224, R225,R231,R232	Am transformer	AMRT 1/2W 560 Ω
	2	910 Ω	R47,R48	KOA	AMRT 1/2W 910 Ω
	21	10 k Ω	R60,R63,R70,R72,R73,R74,R75,R76, R77,R78,R79,R84,R85,R86,R87,R88, R89,R90,R98,R102,R103	KOA	RK73B1JTTD103J
	4	1 k Ω	R33,R34,R204,R205	Am transformer	AMRT 1/2W 1k Ω
	3	130 k Ω	R52,R217,R219	Yageo	MFR-25FBF52-130K
	1	150 k Ω	R215	Yageo	MFR-25FBF52-150K
	2	2.2 k Ω	R58,R59	Koa	RK73B1JTTD222J
	1	2.4 k Ω	R55	Koa	RK73B1JTTD242J
	2	22 k Ω	R4,R5	Yageo	MFR-25FBF52-22K
	6	3.3 k Ω	R53,R69,R71,R99,R100,R220	Koa	RK73B1JTTD332J
	4	330 Ω	R35,R36,R206,R207	Am transformer	AMRT 1/2W 330 Ω
	3	56 k Ω	R50,R214,R216	Yageo	MFR-25FRF52-56K
	1	68 k Ω	R218	Yageo	MFR-25FRF52-68K
	2	100 k Ω	R223,R228	Am transformer	AMRT 1/2W 100k Ω
4	300 Ω	R226,R227,R229,R230	Am transformer	AMRT 1/2W 300 Ω	

	Quantity	Type	Component No.	Manufacturer	Product No.
Switch	1	Rotary Switch	S1	Excel Cell Electronic	ERD216RSZ
	1	SPDT Switch	SW1	NKK Switches	SS-12SBP2
	2	Tactile Switch	SW2,SW3	Alps Alpine	SKHHAJA010
	2	DPDT Switch	SW5,SW6	NKK Switches	SS-22SDP2
IC	1	Selector	U14	ON Semiconductor	74FST3257
	1	DAC	U11	ROHM	BD34301EKV
	4	Audio Regulator	U9,U19,U20,U21	ROHM	BD37201NUX
	4	LDO	U7,U8,U17,U18	Texas Instruments	LM317S
	1	EEPROM	U22	ROHM	BR24G1M-3A
	1	Digital Isolator	U15	Texas Instruments	ISO7640FM
	4	Op-amp	U2,U3,U5,U6	Texas Instruments	NE5532ADR
	1	MCU	U12	Microchip	PIC16F88
	1	Digital Audio I/F	U16	Texas Instruments	PCM9211
	X'tal	1	SPXO	X1	DAISHINKU

Notes

- 1) The information contained herein is subject to change without notice.
- 2) Before you use our Products, please contact our sales representative and verify the latest specifications :
- 3) Although ROHM is continuously working to improve product reliability and quality, semiconductors can break down and malfunction due to various factors.
Therefore, in order to prevent personal injury or fire arising from failure, please take safety measures such as complying with the derating characteristics, implementing redundant and fire prevention designs, and utilizing backups and fail-safe procedures. ROHM shall have no responsibility for any damages arising out of the use of our Products beyond the rating specified by ROHM.
- 4) Examples of application circuits, circuit constants and any other information contained herein are provided only to illustrate the standard usage and operations of the Products. The peripheral conditions must be taken into account when designing circuits for mass production.
- 5) The technical information specified herein is intended only to show the typical functions of and examples of application circuits for the Products. ROHM does not grant you, explicitly or implicitly, any license to use or exercise intellectual property or other rights held by ROHM or any other parties. ROHM shall have no responsibility whatsoever for any dispute arising out of the use of such technical information.
- 6) The Products specified in this document are not designed to be radiation tolerant.
- 7) For use of our Products in applications requiring a high degree of reliability (as exemplified below), please contact and consult with a ROHM representative : transportation equipment (i.e. cars, ships, trains), primary communication equipment, traffic lights, fire/crime prevention, safety equipment, medical systems, servers, solar cells, and power transmission systems.
- 8) Do not use our Products in applications requiring extremely high reliability, such as aerospace equipment, nuclear power control systems, and submarine repeaters.
- 9) ROHM shall have no responsibility for any damages or injury arising from non-compliance with the recommended usage conditions and specifications contained herein.
- 10) ROHM has used reasonable care to ensure the accuracy of the information contained in this document. However, ROHM does not warrants that such information is error-free, and ROHM shall have no responsibility for any damages arising from any inaccuracy or misprint of such information.
- 11) Please use the Products in accordance with any applicable environmental laws and regulations, such as the RoHS Directive. For more details, including RoHS compatibility, please contact a ROHM sales office. ROHM shall have no responsibility for any damages or losses resulting non-compliance with any applicable laws or regulations.
- 12) When providing our Products and technologies contained in this document to other countries, you must abide by the procedures and provisions stipulated in all applicable export laws and regulations, including without limitation the US Export Administration Regulations and the Foreign Exchange and Foreign Trade Act.
- 13) This document, in part or in whole, may not be reprinted or reproduced without prior consent of ROHM.



Thank you for your accessing to ROHM product informations.
More detail product informations and catalogs are available, please contact us.

ROHM Customer Support System

<http://www.rohm.com/contact/>