

DESCRIPTION

The TX4139 is a monolithic step-down switch mode converter. It achieves 2A continuous output current over a wide input supply range with excellent load and line regulation.

The maximum peak current can be programmed by sensing current through an accurate sense resistor.

Fault condition protection includes cycle-by-cycle current limiting and thermal shutdown.

The TX4139 requires a minimum number of readilyavailable standard external components. TheTX4139 is available in 8-pin ESOIC8 packages.

FEATURES

- ◆ Wide 4.5V to 75V Operating Input Range
- ◆ Output Adjustable from 0.8V to 50V
- ◆ Light load High Efficiency
- ◆ Power Save Mode at light load
- ◆ Programmable maximum peak current
- ◆ 130mΩ Internal Power MOSFET Switch
- ◆ 91.8% Efficiency at $V_{in}=72V$, $V_{out}=12V@1.2A$
- ◆ 81.4% Efficiency at $V_{in}=72V$, $V_{out}=5V@0.8A$
- ◆ Fixed 200KHz Frequency
- ◆ Thermal Shutdown
- ◆ Cycle-by-Cycle Over Current Protection
- ◆ Available in 8-Pin ESOIC8 Packages

APPLICATIONS

- ◆ Balance Bike
- ◆ ebike
- ◆ USB Power Supplies

TYPICAL APPLICATION

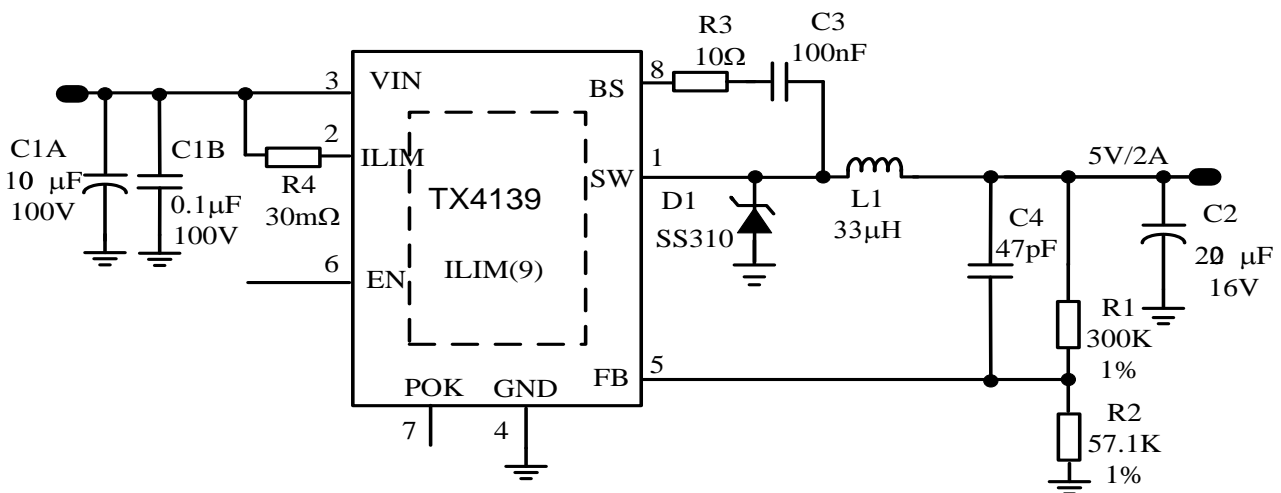

ORDERING INFORMATION

PART NUMBER	TX4139
TEMPERATURE RANGE	-40°C to 85°C
PACKAGE	ESOIC8

PIN CONFIGURATION

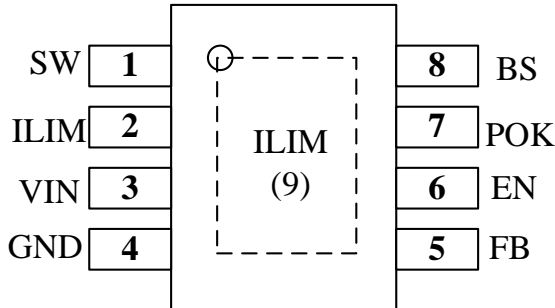

ABSOLUTE MAXIMUM RATINGS ⁽¹⁾

Supply Voltage V_{IN}, V_{ILIM}	76V
V_{SW}	-0.3V to $V_{IN} + 0.3V$
V_{BST}	$V_{SW} + 6.0V$
V_{POK}	0V to 45V
All Other Pins	-0.3V to +6.5V
Junction Temperature	150°C
Lead Temperature	260°C
Storage Temperature	-65°C to +150°C

Recommended Operating Conditions ⁽²⁾

Supply Voltage V_{IN}	4.5V to 75V
Output Voltage V_{OUT}	0.8V to 40V
Operating Temperature	-40°C to +85°C

Thermal Resistance ⁽³⁾	θ_{JA}	θ_{JC}
ESOIC8	45	15 ... °C/W

Notes:

- Exceeding these ratings may damage the device.
- The device is not guaranteed to function outside of its operating conditions.
- Measured on approximately 42x45mm² of 1 oz copper.

PIN No.	PIN NAME	PIN DESCRIPTION
1	SW	Switch Output. Connect this pin to the switching end of the inductor.
2、9	ILIM	programmable maximum peak current pin by sensing current through an accurate sense resistor between this pin and VIN.
3	VIN	Supply Voltage. The TX4139 operates from a +4.5V to +75V unregulated input. C_{IN} is needed to prevent large voltage spikes from appearing at the input. Put C_{IN} as close to the IC as possible. It is the drain of the internal power device and power supply for the whole chip.
4	Gnd	Ground. This pin is the voltage reference for the regulated output voltage. For this reason care must be taken in its layout. This node should be placed outside of the D1 to C_{IN} ground path to prevent switching current spikes from inducing voltage noise into the part.
5	FB	Feedback. An external resistor divider from the output to GND, tapped to the FB pin sets the output voltage. To prevent current limit run away during a short circuit fault condition the frequency-fold-back comparator lowers the oscillator frequency when the FB voltage is below 250mV.
6	EN	Enable pin. Connect to low off the chip, Floating is enable
7	POK	Power good signal. When FB is less than 90% of 0.8V, PGOOD is low. It is an open-drain output. Use a high value pull-up resistor externally to pull it up to system power supply or its output as next chip enable signal. connected to Gnd or floating when don't use this function.
8	BS	Bootstrap. This pin acts as the positive rail for the high-side switch's gate driver. Connect a 100nF ceramic cap and 10ohm resistor between this pin and SW.

ELECTRICAL CHARACTERISTICS

$V_{IN} = 12V$, $T_A = +25^{\circ}C$, unless otherwise noted.

PARAMETER	SYMBOL	TEST CONDITIONS	MIN	TYP	MAX	UNIT
Feedback Voltage	V_{FB}	$4.5V \leq V_{IN} \leq 80V$	0.785	0.805	0.825	V
Feedback Bias Current	$I_{BIAS(FB)}$	$V_{FB} = 0.8V$		10		nA
Switch On Resistance	$R_{DS(ON)}$			130		m Ω
Current Limit (4)			1.2	1.35	1.5	A
Oscillator Frequency	f_{SW}	$V_{FB} = 0.6V$	160	200	240	KHz
Fold-Back Frequency		$V_{FB} = 0V$		70		KHz
Boot-Strap Voltage	$V_{BST} - V_{SW}$			6		V
Minimum On Time (5)	t_{ON}	$V_{FB} = 1V$		100		ns
Under Voltage Lockout Threshold Rising			3.0	3.3	3.6	V
Under Voltage Lockout Threshold Hysteresis			200			mV
Supply Current (Quiescent)		$V_{EN} = 2V$, $V_{FB} = 1V$		400	700	μA
Thermal Shutdown (5)				160		$^{\circ}C$

Note:

- 4) sense resistor defined
5) Guaranteed by design

OPERATION

Main Control Loop

The TX4139 is a current mode buck regulator. That is, the error amplifier (EA) output voltage is proportional to the peak inductor current. At the beginning of a cycle, the integrated high side power switch M1 is off; the EA output voltage is higher than the current sense amplifier output; and the current comparator's output is low. The rising edge of the 200KHz clock signal sets the RS Flip-Flop. Its output turns on M1 thus connecting the SW pin and inductor to the input supply.

The increasing inductor current is sensed and amplified by the Current Sense Amplifier. Ramp compensation is added to Current Sense Amplifier output and compared to the Error Amplifier output by the PWM Comparator. When the Current Sense Amplifier plus Slope Compensation signal exceeds the EA output voltage, the RS Flip-Flop is reset and the TX4139 reverts to its initial M1 off state. If the Current Sense Amplifier plus Slope Compensation signal does not exceed the COMP voltage, then the falling edge of the CLK resets the Flip-Flop. The output of the Error Amplifier integrates the voltage difference between the feedback and the 0.8V

bandgap reference. The polarity is such that a FB pin voltage lower than 0.8V increases the EA output voltage. Since the EA output voltage is proportional to the peak inductor current, an increase in its voltage increases current delivered to the output. An external Schottky Diode (D1) carries the inductor current when internal power MOS is off.

APPLICATION INFORMATION

Setting the Output Voltage

The external resistor divider is used to set the output voltage (see the schematic on front page). The feedback resistor R1 also sets the feedback loop bandwidth with the internal compensation capacitor (see Figure 1). Choose R1 to be around 300k Ω for optimal transient response. R2 is then given by:

$$R2 = \frac{R1}{V_{OUT} / 0.805 - 1}$$

Table 1 –Resistor Selection for Common

Vout(V)	R1(K Ω)	R2(K Ω)
3.3	300(1%)	96(1%)
5	300(1%)	57.1(1%)
12	300(1%)	21.4(1%)
15	300(1%)	16.9(1%)
24	300(1%)	10.2(1%)
32	300(1%)	7.6(1%)

Selecting the Inductor

33μH to 100μH inductor with a DC current rating of at least 30% percent higher than the maximum load current is recommended for most applications. For highest efficiency, the inductor DC resistance should be less than 50mΩ. For most designs, the inductance value can be derived from the following equation.

$$L = \frac{V_{OUT} \times (V_{IN} - V_{OUT})}{V_{IN} \times \Delta I_L \times f_{SW}}$$

Where ΔIL is the inductor ripple current. Choose inductor current ripple to be approximately 30%-40% of the maximum load current,. The maximum inductor peak current is:

$$I_{L(MAX)} = I_{out(MAX)} + \frac{\Delta I_L}{2}$$

Under light load conditions below 100mA, larger inductance is recommended for improved efficiency.

Selecting the Input Capacitor

The input capacitor reduces the surge current drawn from the input and also the switching noise from the device. The input capacitor impedance at the switching frequency should be less than the input source impedance to prevent high frequency switching current from pass to the input. For most applications, a 47uF to 100uF electrolytic capacitor is sufficient.

Selecting the Output Capacitor

The output capacitor keeps output voltage small and ensures regulation loop stability. The output capacitor impedance should be low at the switching frequency. a 220uF electrolytic capacitor is recommended.

ILIM sense resistor

Power current flow into the chip via the external accuracy sense resistor which defined the maximum peak current. In guarantee under the normal start up with full load, the sense resistor is recommended use the larger value to ensure less surge current and output output short power dissipation. The sense resistor value should be reduced when used it at low temperature situation to ensure enough startup energy.

Table 2 –Sense Resistor Selection

Max. output current (A)	Rsense (mΩ)
0.8	50
1.0	40
2.0	30

Loop compensation

A 12pf-82pf ceramic capacitor connected between FB and OUT can optimize the loop stability for both bandwidth and phase margin, recommended a 22-47pf ceramic capacitor in most case.

PCB Layout

- 1) Under the large output current and high input voltage case, the schottky diode and the converter is the main heat source, don't put them too close, the PCB layout should keep enough area for heat dissipation. Recommended ratio is 6:4 for schottky diode and the convertor, for the cost issues, the normal selection of PCB is 1oz thickness, the thick solder tin is benefit on heat dissipation.
- 2) ILIM is internal connected the power MOS, the heat dissipation should be considered for this pin.
- 3) The large current path (ILIM、SW) should be put closer the converter as possible, use short, straight, wide copper foil connect.
- 4) Input capacitor should be put as close as possible to Vin and GND.
- 5) The loop of input capacitor, internal power MOS and schottky diode is the highest di/dt radiation region, reduce this region as possible. a 0.1uF ceramic capacitor can be used to form a small loop with internal power MOS and schottky diode, which can reduce the switch ringing caused by PCB parasitic inductor.
- 6) The outside feedback resistor should be placed nearby the FB pin and keep away from SW node.
- 7) A 220pf ceramic capacitor between VIN and SW pin can be used to reduce the switch negative overshoot and improve EMI performance when needed.

TYPICAL APPLICATION

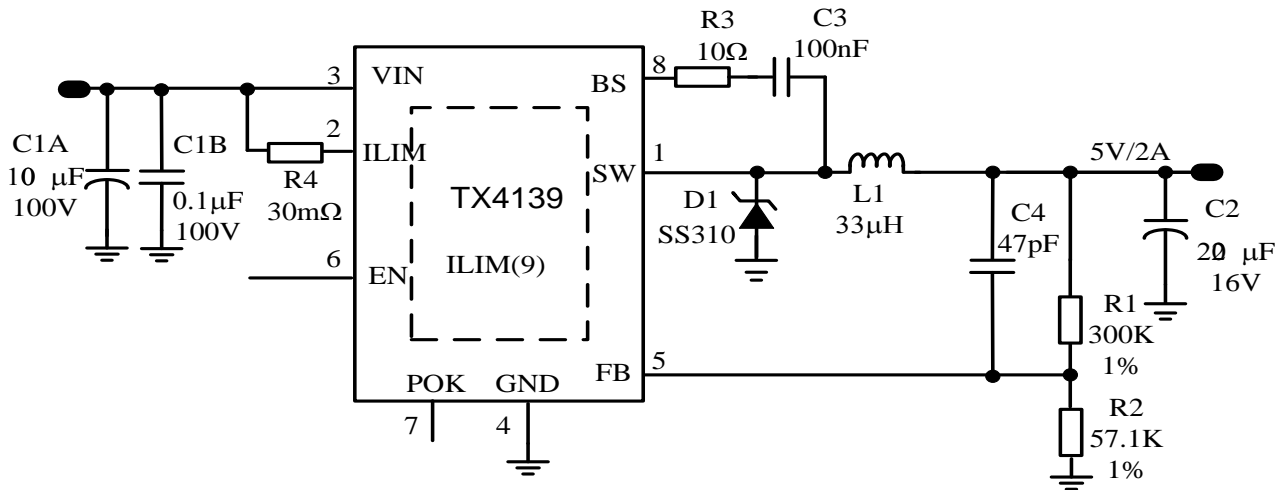

5V/2A BOM LIST:

Ref	Value	Description	Package	Manufacturer	Qty	Manufacturer P/N
C1A	100uF	Electrolytic,100V	ELC SMD	jiang hai	1	VTD-100V100
C1B	0.1uF	Ceramic capacitor,100V	0603	muRata	1	GRM188R71C104K
C2	220uF	Electrolytic,16V	ELC SMD	jiang hai	1	VTD-100V220
C3	100nF	Ceramic capacitor, 100V, X7R	0603	muRata	1	GRM188R71C104K
C4	47pF	Ceramic, capacitor 25V, X7R	0603	muRata	1	GRM32DR71E470K
D1	3A	Schottky Diode, SMD, 100V, 3A	SMB		1	SS310
L1	33uH	Inductor CDRH104, 2.4A	CDRH104		1	
R1	300KΩ	Film Res., 1%	0603	Panasonic	1	ERJ-3EKF3003V
R2	57.1KΩ	Film Res., 1%	0603	Panasonic	1	ERJ-3EKF5712V
R3	10Ω	Film Res., 1%	0603	Panasonic	1	ERJ-3EKF0011V
R4	30mΩ	Film Res., 1%	1206		1	
U1		DC-DC convertor	ESOP8	TX4139	1	

Note: recommended to use a low Vf schottky diode for efficiency promotion.

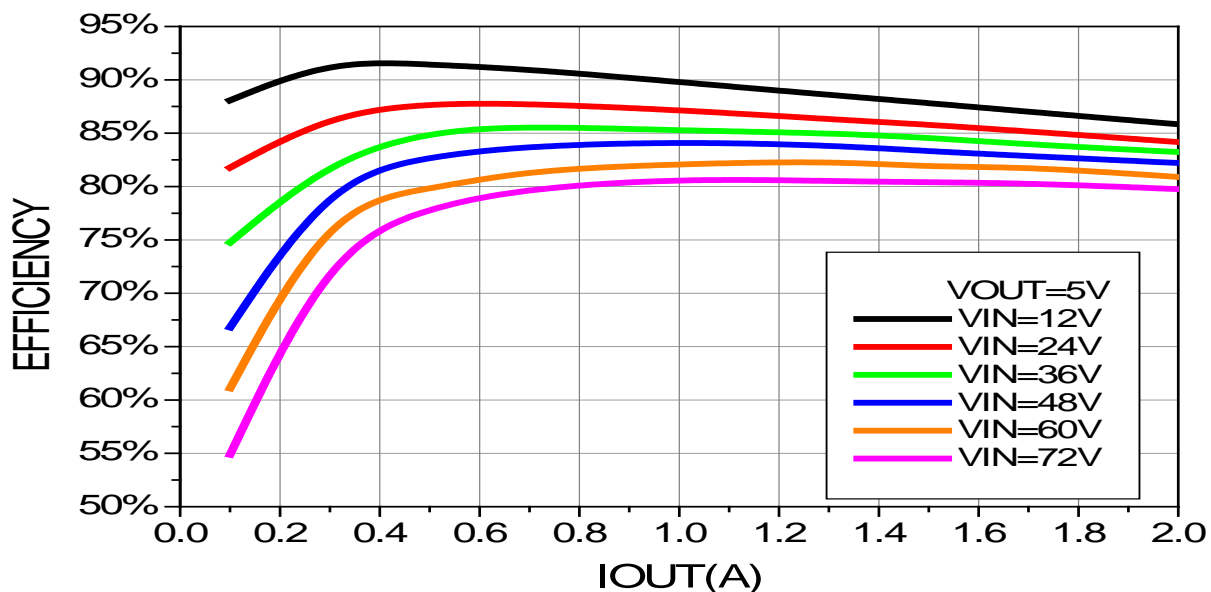

TYPICAL APPLICATION

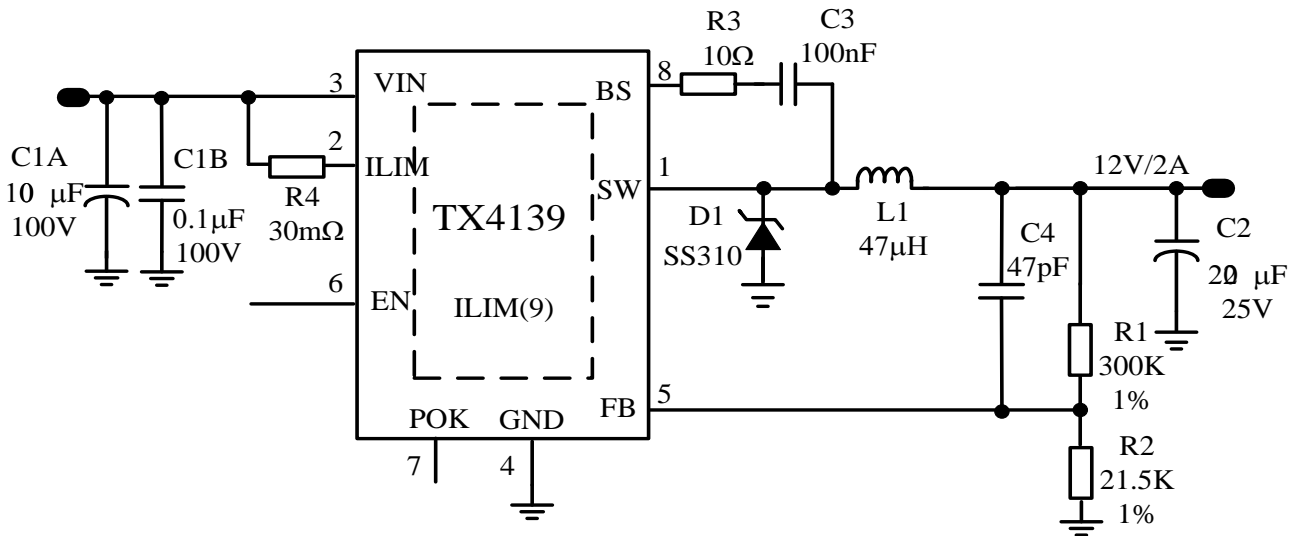

12V/2A BOM LIST:

Ref	Value	Description	Package	Manufacturer	Qty	Manufacturer P/N
C1A	100uF	Electrolytic,100V	ELC SMD	jiang hai	1	VTD-100V100
C1B	0.1uF	Ceramic capacitor,100V	0603	muRata	1	GRM188R71C104K
C2	220uF	Electrolytic,25V	ELC SMD	jiang hai	1	VTD-100V220
C3	100nF	Ceramic capacitor, 100V, X7R	0603	muRata	1	GRM188R71C104K
C4	47pF	Ceramic, capacitor 25V, X7R	0603	muRata	1	GRM32DR71E470K
D1	3A	Schottky Diode, SMD, 100V, 3A	SMB		1	SS310
L1	47uH	Inductor CDRH127, 2.5A	CDRH127		1	
R1	300KΩ	Film Res., 1%	0603	Panasonic	1	ERJ-3EKF3003V
R2	21.5KΩ	Film Res., 1%	0603	Panasonic	1	ERJ-3EKF2152V
R3	10Ω	Film Res., 1%	0603	Panasonic	1	ERJ-3EKF0011V
R4	30mΩ	Film Res., 1%	1206		1	
U1		DC-DC convertor	ESOP8	TX4139	1	

Note: recommended to use a low Vf schottky diode for efficiency promotion.

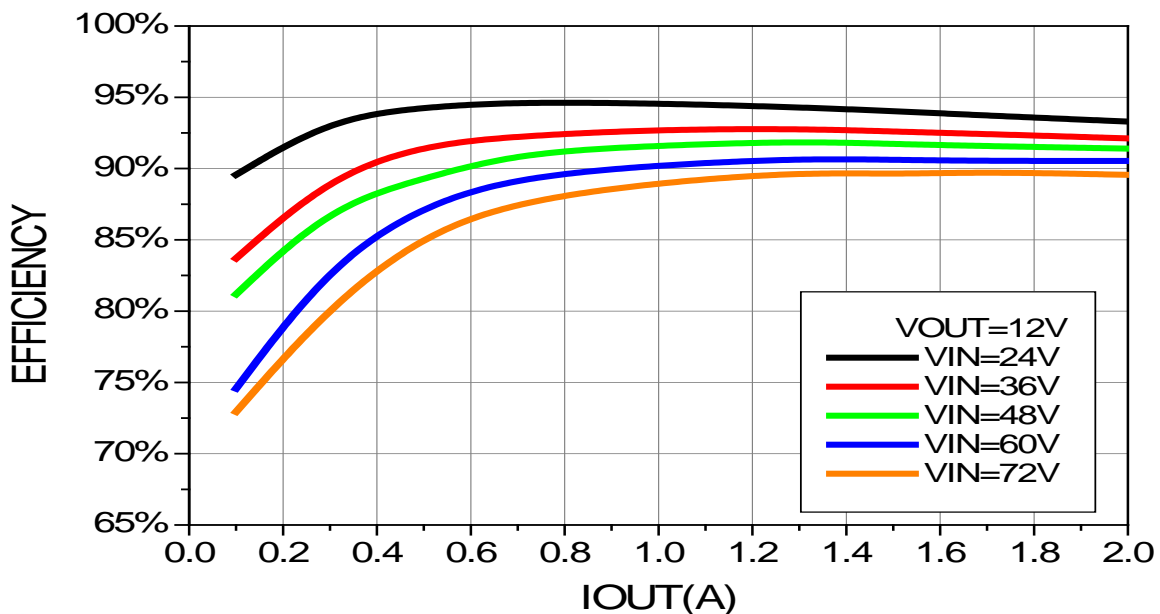

PCB LAYOUT:

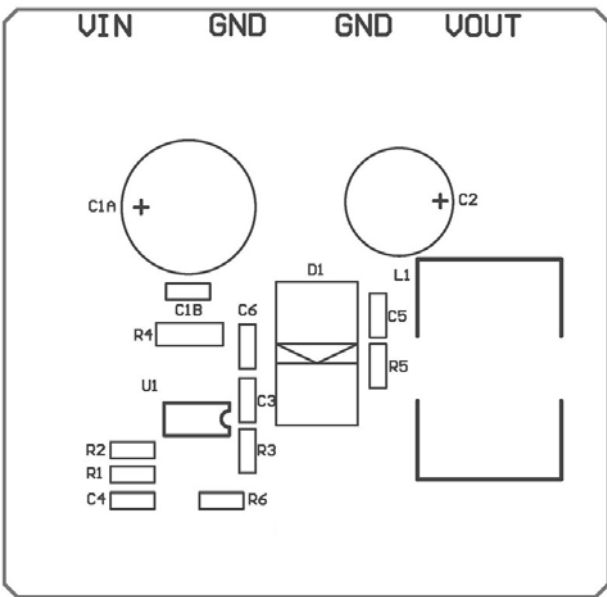
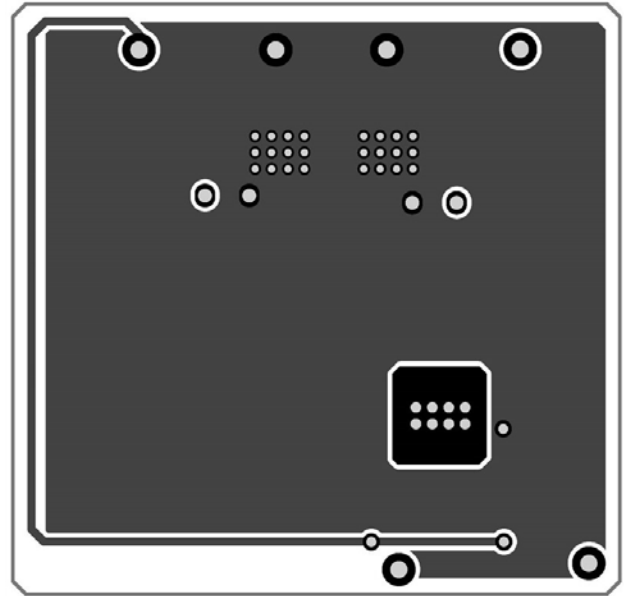
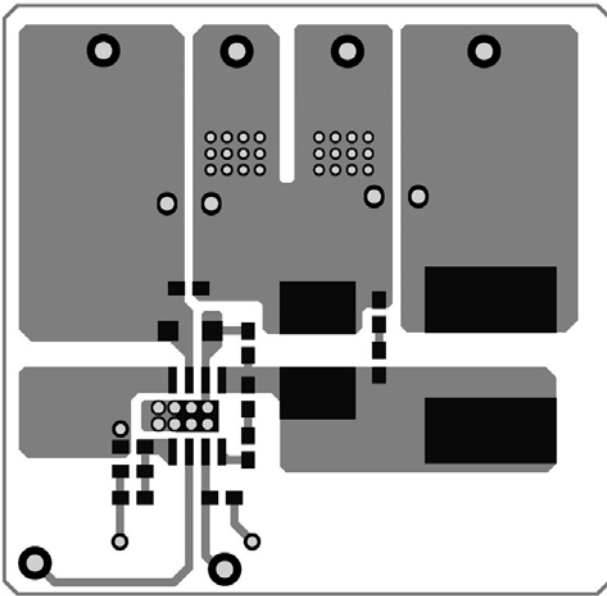

PACKAGE OUTLINE

ESOIC8 PACKAGE OUTLINE AND DIMENSIONS

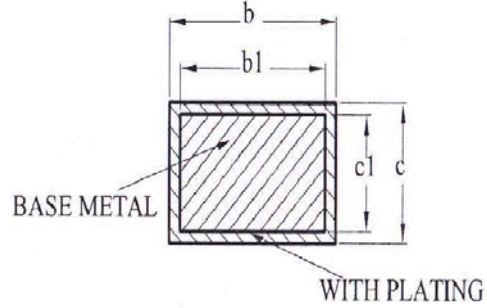
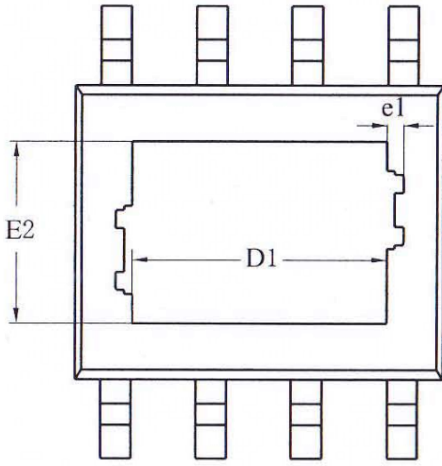

SECTION B-B

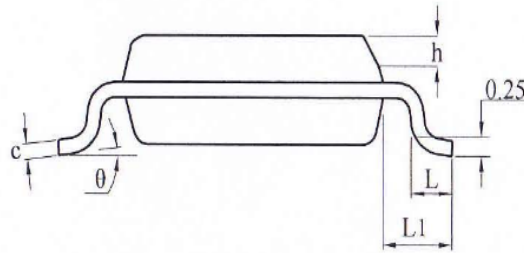
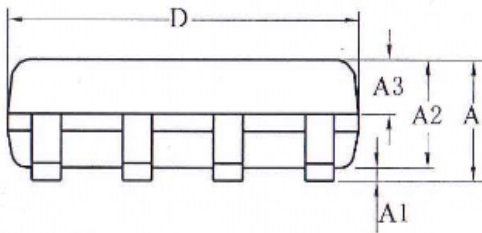

SYMBOL	MILLIMETER		
	MIN	NOM	MAX
A	—	—	1.65
A1	0.05	—	0.15
A2	1.30	1.40	1.50
A3	0.60	0.65	0.70
b	0.39	—	0.47
b1	0.38	0.41	0.44
c	0.20	—	0.24
c1	0.19	0.20	0.21
D	4.80	4.90	5.00
E	5.80	6.00	6.20
E1	3.80	3.90	4.00
e	1.27BSC		
h	0.25	—	0.50
L	0.50	0.60	0.80
L1	1.05REF		
θ	0	—	8°

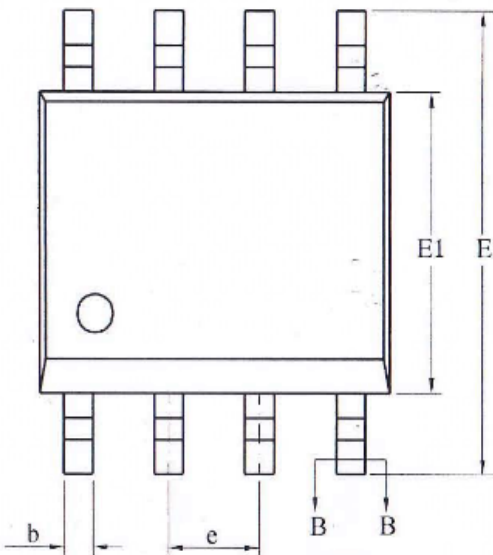

Size (mil)	D1	E2	e1
90*90	2.09REF	2.09REF	0.16REF
95*130	3.10REF	2.21REF	0.10REF