



FIN1001

3.3 V LVDS 1-Bit, High-Speed Differential Driver

Features

- Greater than 600 Mbs Data Rate
- 3.3 V Power Supply Operation
- 0.5 ns Maximum Pulse Skew
- 1.5 ns Maximum Propagation Delay
- Low Power Dissipation
- Power-Off Protection
- Meets or exceeds TIA/EIA-644 LVDS Standard
- Flow-through pin-out simplifies PCB Layout
- 5-Lead SOT23 package saves Space

Description

This single driver is designed for high-speed interconnects utilizing Low Voltage Differential Signaling (LVDS) technology. The driver translates LVTTTL levels to LVDS levels with a typical differential output swing of 350 mV which provides low EMI at ultra low power dissipation even at high frequencies. This device is ideal for high-speed transfer of clock or data. The FIN1001 can be paired with its companion receiver, the FIN1002, or with any other LVDS receiver.

Ordering Information

Part Number	Operating Temperature Range	Package	Packing Method	Packing Quantity
FIN1001M5X	-40 to +125°C	5-Lead SOT23, JEDEC MO-178, 1.6 mm	Tape & Reel	3000

Connection Diagram

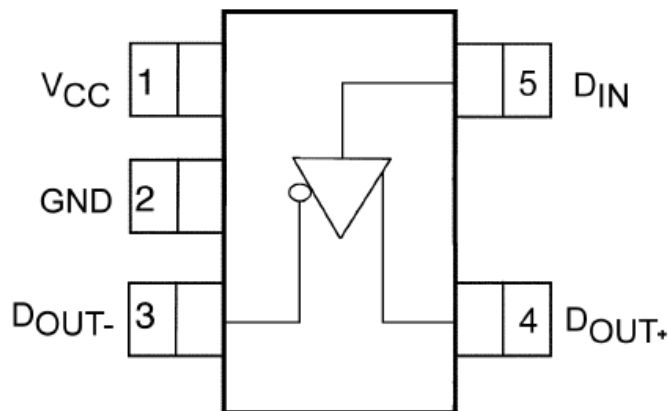

Figure 1. Top View

Pin Definitions

Pin #	Name	Description
1	V _{CC}	Power Supply
2	GND	Ground
3	D _{OUT+}	Non-inverting LVDS Driver Output
4	D _{OUT-}	Inverting LVDS Driver Output
5	D _{IN}	LVTTTL Data Input

Function Table

Input	Outputs	
D _{IN}	D _{OUT+}	D _{OUT-}
LOW	LOW	HIGH
HIGH	HIGH	LOW

Absolute Maximum Ratings

Stresses exceeding the absolute maximum ratings may damage the device. The device may not function or be operable above the recommended operating conditions and stressing the parts to these levels is not recommended. In addition, extended exposure to stresses above the recommended operating conditions may affect device reliability. The absolute maximum ratings are stress ratings only.

Symbol	Parameter	Min.	Max.	Unit
V_{CC}	Supply Voltage	-0.5	4.6	V
D_{IN}	DC Input Voltage	-0.5	6.0	V
D_{OUT}	DC Output Voltage	-0.5	4.6	V
I_{OSD}	Driver Short Circuit Current	Continuous		
I_O	Output Current		16	mA
T_{STG}	Storage Temperature Range	-65	+150	°C
T_J	Maximum Junction Temperature		+150	°C
T_L	Lead Temperature, Soldering, 10 Seconds		+260	°C
ESD	Electrostatic Discharge	Human Body Model	7500	V
		Machine Model	400	V

Recommended Operating Conditions

The Recommended Operating Conditions table defines the conditions for actual device operation. Recommended operating conditions are specified to ensure optimal performance to the datasheet specifications. Fairchild does not recommend exceeding them or designing to Absolute Maximum Ratings.

Symbol	Parameter	Min.	Max.	Unit
V_{CC}	Supply Voltage	3.0	3.6	V
V_{IN}	Input Voltage	0	V_{CC}	V
T_A	Operating Temperature	-40	+125	°C

DC Electrical Characteristics⁽¹⁾

All min and max values are guaranteed at $T_A = -40^\circ$ to $+125^\circ\text{C}$, unless otherwise specified.
All typical values are at $T_A = 25^\circ\text{C}$ and with $V_{CC} = 3.3\text{ V}$, unless otherwise specified.

Symbol	Parameter	Conditions	Min	Typ	Max	Unit	
V_{OD}	Output Differential Voltage	$R_L = 100\ \Omega$, See Figure 2	$T_A = -40^\circ$ to 85°C	250	350	450	mV
			$T_A = -40^\circ$ to 125°C	230	350	450	mV
ΔV_{OD}	V_{OD} Magnitude Change from Differential Low-to-High	$R_L = 100\ \Omega$, See Figure 2	$T_A = -40^\circ$ to 125°C			25	mV
V_{OS}	Offset Voltage			1.125	1.25	1.375	V
ΔV_{OS}	Offset Magnitude Change from Differential Low-to-High				25	mV	
I_{OFF}	Power-Off Output Current	$V_{CC} = 0\text{ V}$, $V_{OUT} = 0\text{ V}$ or 3.6 V			± 20	μA	
I_{OS}	Short Circuit Output Current	$V_{OUT} = 0\text{ V}$		-5.5	-8	mA	
		$V_{OD} = 0\text{ V}$		± 4	± 8		
$I_{I(OFF)}$	Power-OFF Input Current	$V_{CC} = 0\text{ V}$, $V_{IN} = 0\text{ V}$ or 3.6 V			± 20	μA	
V_{IH}	Input HIGH Voltage		2.0		V_{CC}	V	
V_{IL}	Input LOW Voltage		GND		0.8	V	
I_{IN}	Input Current	$V_{IN} = 0\text{ V}$ or V_{CC}			± 20	μA	
$I_{I(OFF)}$	Power-Off Input Current	$V_{CC} = 0\text{ V}$, $V_{IN} = 0\text{ V}$ or 3.6 V			± 20	μA	
V_{IK}	Input Clamp Voltage	$I_{IK} = -18\text{ mA}$	-1.5	-0.8		V	
I_{CC}	Power Supply Current	No Load, $V_{IN} = 0\text{ V}$ or V_{CC}		4.5	8	mA	
		$R_L = 100\ \Omega$, $V_{IN} = 0\text{ V}$ or V_{CC}		6.5	10		
C_{IN}	Input Capacitance	$V_{CC} = 3.3\text{ V}$		3.2		pF	
C_{OUT}	Output Capacitance	$V_{CC} = 0\text{ V}$		3.3		pF	

Notes:

- Not production tested across the full temperature range.

AC Electrical Characteristics

All min and max values are guaranteed at $T_A = -40$ to $+85^\circ\text{C}$.
All typical values are at $T_A = 25^\circ\text{C}$ and with $V_{CC} = 3.3\text{ V}$, unless otherwise specified.
 $R_L = 100\ \Omega$, $C_L = 5\text{ pF}$. See Figure 3 and Figure 4.

Symbol	Parameter	Conditions	Min.	Typ.	Max.	Unit
t_{PLHD}	Propagation Delay	LOW to HIGH	0.50	0.98	1.50	ns
t_{PHLD}	Propagation Delay	HIGH to LOW	0.50	0.93	1.50	ns
t_{TLHD}	Differential Output Rise Time	20% to 80%	0.4	0.5	1.0	ns
t_{THLD}	Output Fall Time	80% to 20%	0.4	0.5	1.0	ns
$t_{SK(p)}$	Pulse Skew	$ t_{PLH} - t_{PHL} $		0.05	0.5	ns
$t_{SK(PP)}$	Part-to-Part Skew ⁽²⁾				1.0	ns

Note:

- $t_{SK(PP)}$ is the magnitude of the difference in propagation delay times between any specified terminals of two devices switching in the same direction (either LOW-to-HIGH or HIGH-to-LOW) when both devices operate with the same supply voltage, same temperature, and have identical test circuits.

Test Diagrams

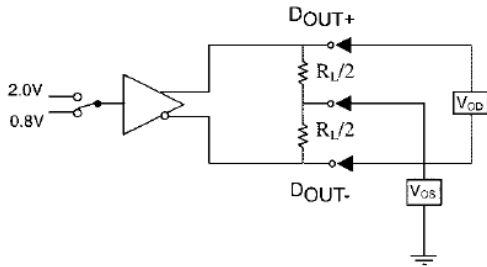
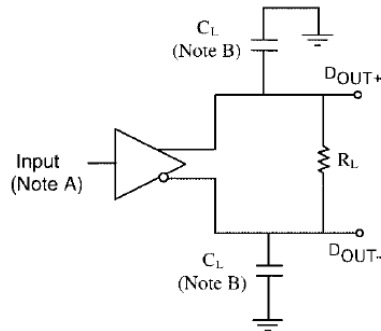

Figure 2. Differential Driver DC Test Circuit



Note A: All input pulses have frequency = 10 MHz, t_R or t_F = 2 ns
 Note B: C_L includes all probe and fixture capacitances

Figure 3. Differential Driver Propagation Delay and Transition Time Test Circuit

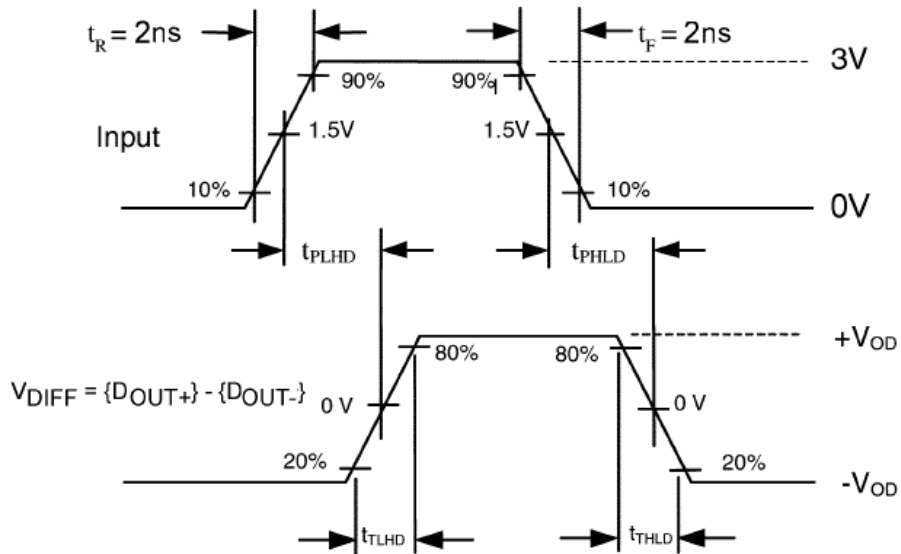

Figure 4. AC Waveforms

Typical Performance Characteristics

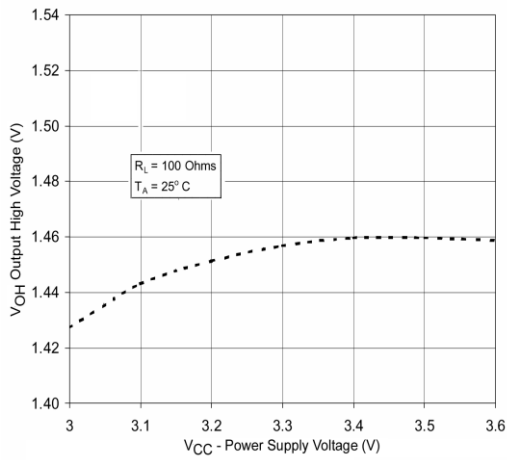

Figure 5. Output High Voltage vs. Power Supply Voltage

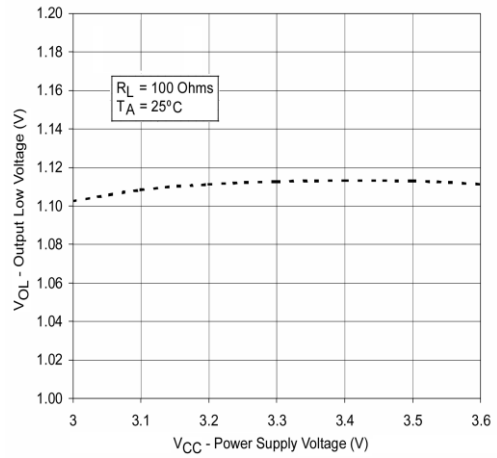

Figure 6. Output Low Voltage vs. Power Supply Voltage

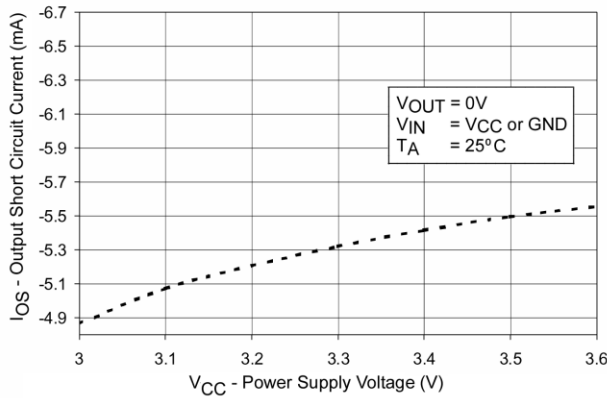

Figure 7. Output Short Circuit Current vs. Power Supply Voltage

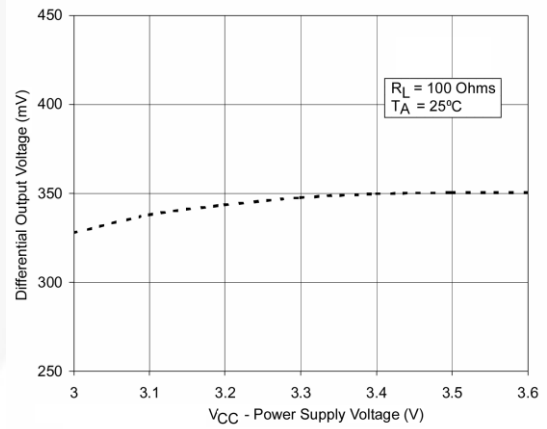

Figure 8. Differential Output Voltage vs. Power Supply Voltage

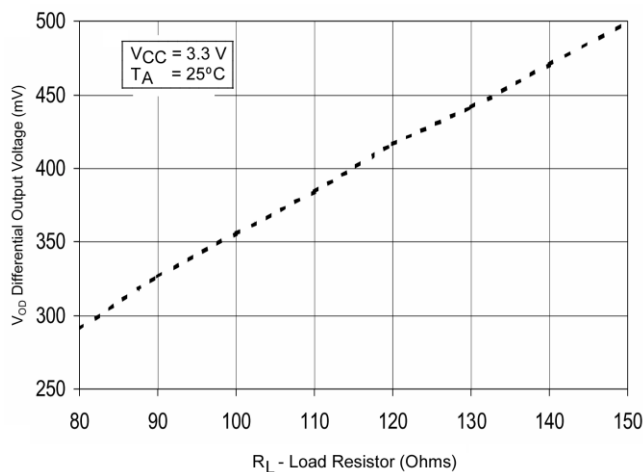

Figure 9. Differential Output Voltage vs. Load Resistor

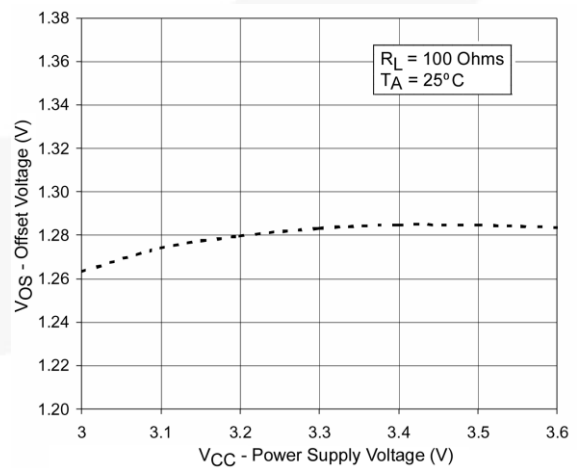

Figure 10. Offset Voltage vs. Power Supply Voltage

Typical Performance Characteristics (Continued)

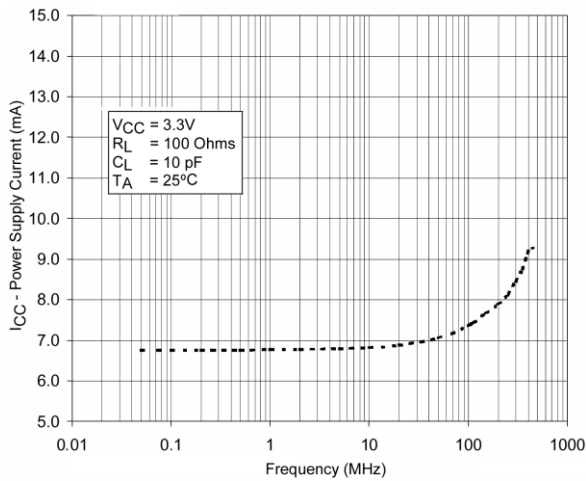

Figure 11. Power Supply Current vs. Frequency

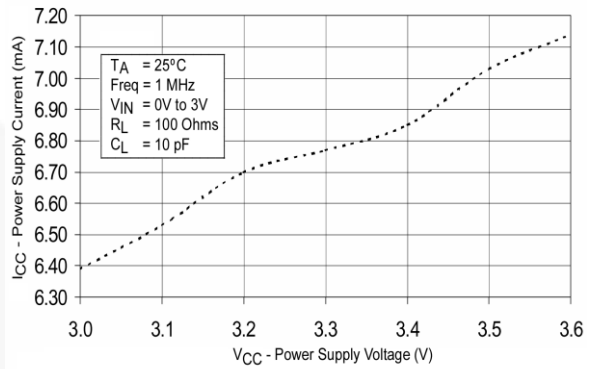

Figure 12. Power Supply Current vs. Power Supply Voltage

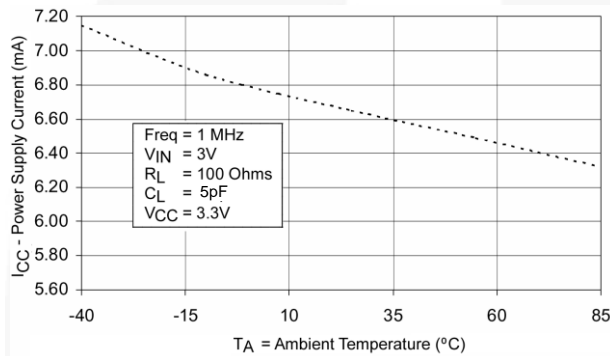

Figure 13. Power Supply Current vs. Ambient Temperature

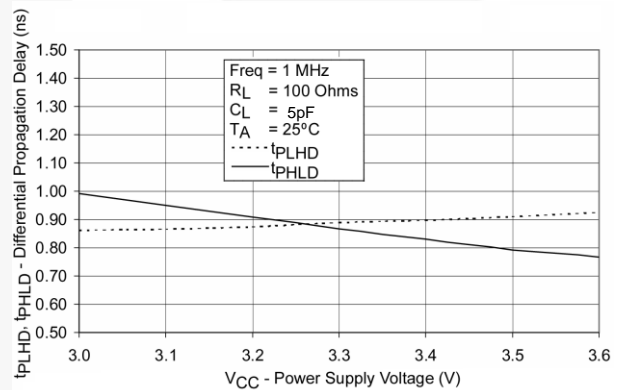

Figure 14. Differential Propagation Delay vs. Power Supply

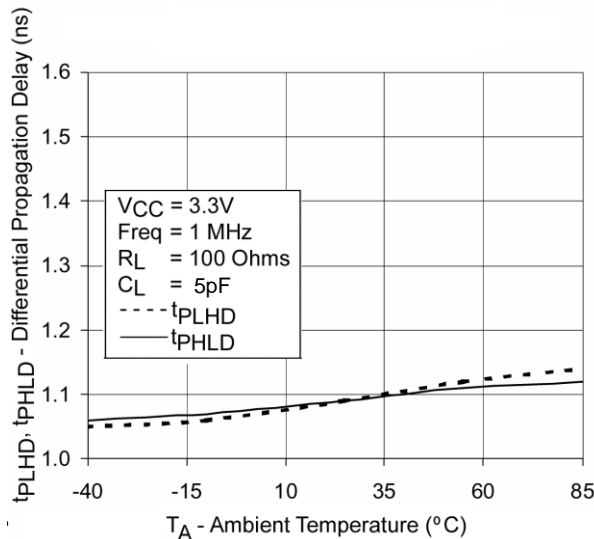

Figure 15. Differential Propagation Delay vs. Ambient Temperature

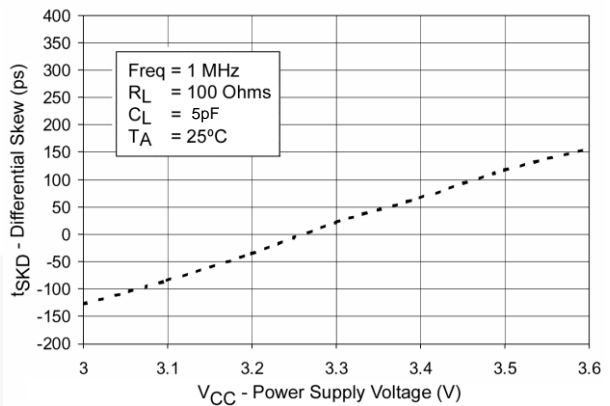

Figure 16. Differential Pulse Skew ($t_{PLH} - t_{PHL}$) vs. Power Supply Voltage

Typical Performance Characteristics (Continued)

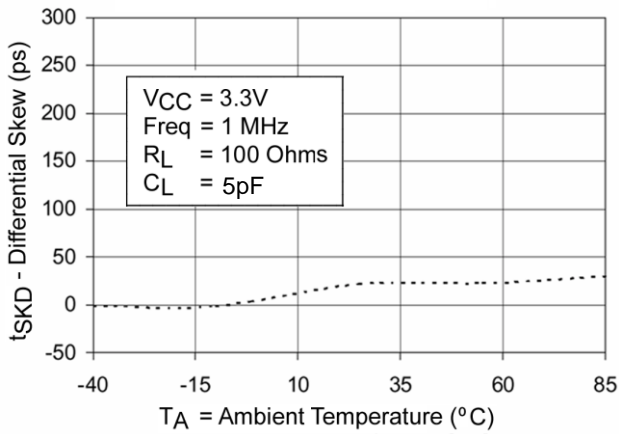

Figure 17. Differential Pulse Skew ($t_{PLH} - t_{PHL}$) vs. Ambient Temperature

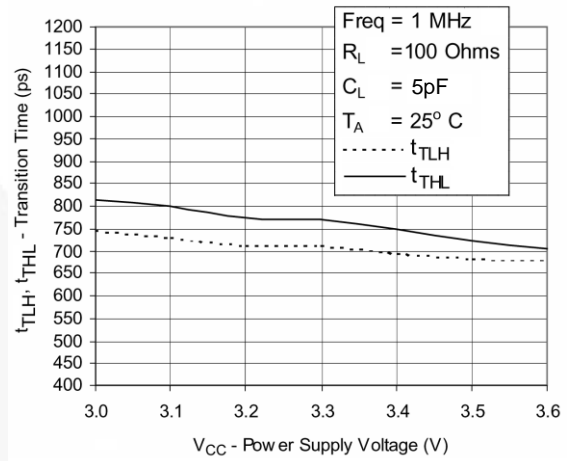

Figure 18. Transition Time vs. Power Supply Voltage

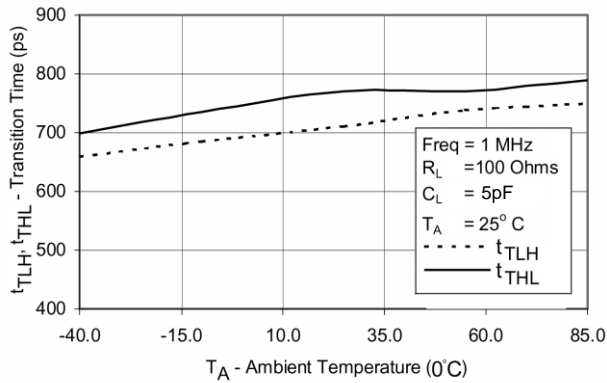
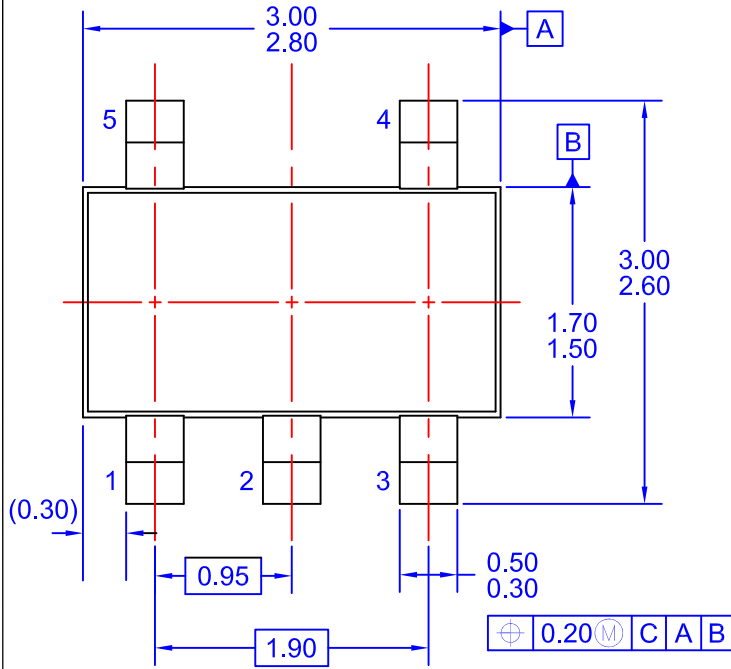
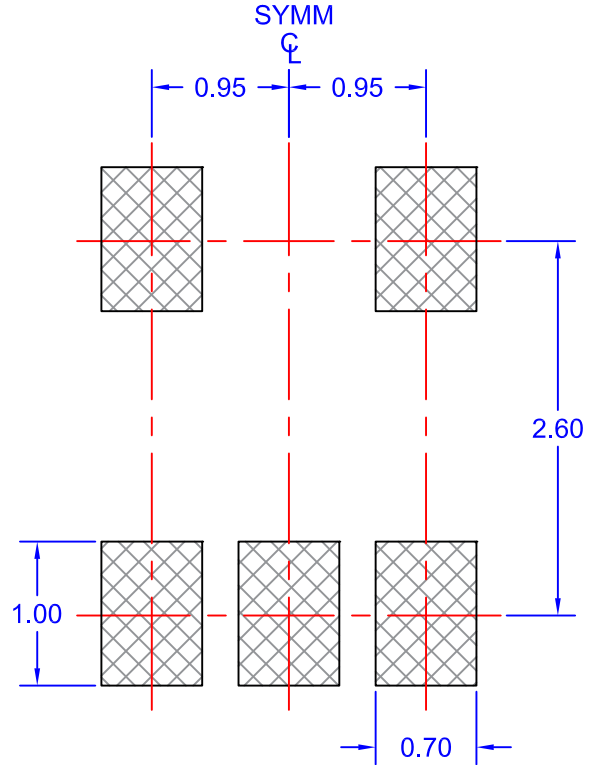

Figure 19. Transition Time vs. Ambient Temperature



TOP VIEW



LAND PATTERN RECOMMENDATION

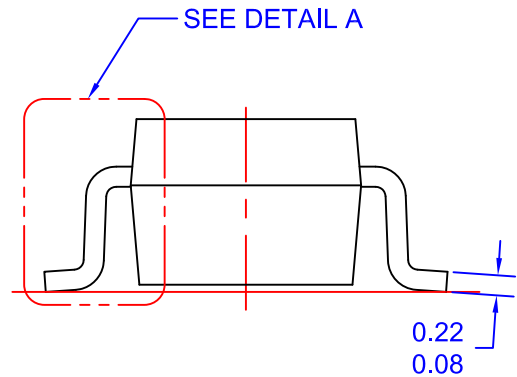
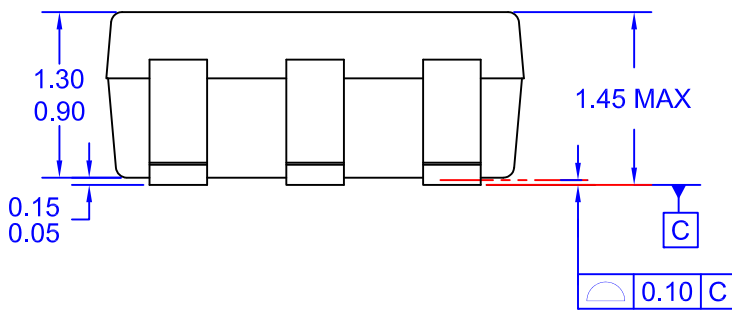

- NOTES: UNLESS OTHERWISE SPECIFIED
- A) PACKAGE STANDARD REFERENCE: JEDEC REGISTRATION, MO-178, ISSUE B, VARIATION AA.
 - B) ALL DIMENSIONS ARE IN MILLIMETERS.
 - C) DIMENSIONS DO NOT INCLUDE BURRS OR MOLD FLASH. MOLD FLASH OR BURRS DOES NOT EXCEED 0.10MM.
 - D) DIMENSIONING AND TOLERANCING PER ASME Y14.5M-2009.
 - E) DRAWING FILE NAME: MKT-MA05BREV6

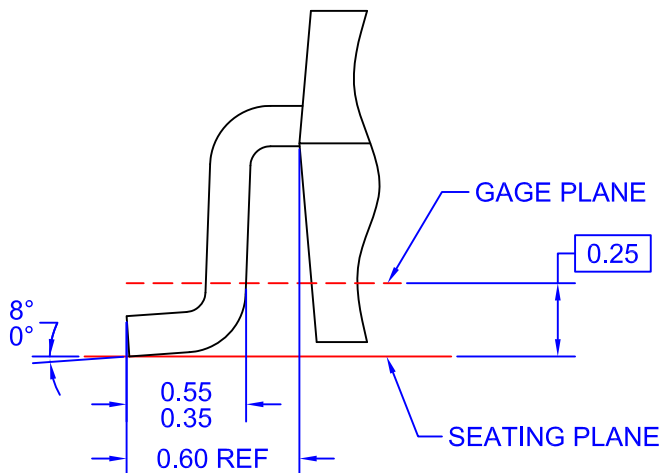



TRADEMARKS

The following includes registered and unregistered trademarks and service marks, owned by Fairchild Semiconductor and/or its global subsidiaries, and is not intended to be an exhaustive list of all such trademarks.

- AccuPower™
- AttitudeEngine™
- Awinda®
- AX-CAP®*
- BitSiC™
- Build it Now™
- CorePLUS™
- CorePOWER™
- CROSSVOL™
- CTL™
- Current Transfer Logic™
- DEUXPEED®
- Dual Cool™
- EcoSPARK®
- EfficientMax™
- ESBC™
- F**™
- Fairchild®
- Fairchild Semiconductor®
- FACT Quiet Series™
- FACT®
- FastvCore™
- FETBench™
- FPS™
- F-PFS™
- FRFET®
- Global Power ResourceSM
- GreenBridge™
- Green FPS™
- Green FPS™ e-Series™
- Gmax™
- GTO™
- IntelliMAX™
- ISOPLANAR™
- Making Small Speakers Sound Louder and Better™
- MegaBuck™
- MICROCOUPLER™
- MicroFET™
- MicroPak™
- MicroPak2™
- MillerDrive™
- MotionMax™
- MotionGrid®
- MTi®
- MTx®
- MVN®
- mWSaver®
- OptoHiT™
- OPTOLOGIC®
- OPTOPLANAR®
- ®
- Power Supply WebDesigner™
- PowerTrench®
- PowerXS™
- Programmable Active Droop™
- QFET®
- QS™
- Quiet Series™
- RapidConfigure™
- ™
- Saving our world, 1mW/W/kW at a time™
- SignalWise™
- SmartMax™
- SMART START™
- Solutions for Your Success™
- SPM®
- STEALTH™
- SuperFET®
- SuperSOT™-3
- SuperSOT™-6
- SuperSOT™-8
- SupreMOS®
- SyncFET™
- Sync-Lock™
- ®
- TinyBoost®
- TinyBuck®
- TinyCalc™
- TinyLogic®
- TINYOPTO™
- TinyPower™
- TinyPWM™
- TinyWire™
- TranSiC™
- TriFault Detect™
- TRUECURRENT®*
- μSerDes™
- ™
- UHC®
- Ultra FRFET™
- UniFET™
- VCX™
- VisualMax™
- VoltagePlus™
- XS™
- Xsens™
- 仙童®

* Trademarks of System General Corporation, used under license by Fairchild Semiconductor.

DISCLAIMER

FAIRCHILD SEMICONDUCTOR RESERVES THE RIGHT TO MAKE CHANGES WITHOUT FURTHER NOTICE TO ANY PRODUCTS HEREIN TO IMPROVE RELIABILITY, FUNCTION, OR DESIGN. TO OBTAIN THE LATEST, MOST UP-TO-DATE DATASHEET AND PRODUCT INFORMATION, VISIT OUR WEBSITE AT [HTTP://WWW.FAIRCHILDSEMI.COM](http://www.fairchildsemi.com). FAIRCHILD DOES NOT ASSUME ANY LIABILITY ARISING OUT OF THE APPLICATION OR USE OF ANY PRODUCT OR CIRCUIT DESCRIBED HEREIN; NEITHER DOES IT CONVEY ANY LICENSE UNDER ITS PATENT RIGHTS, NOR THE RIGHTS OF OTHERS. THESE SPECIFICATIONS DO NOT EXPAND THE TERMS OF FAIRCHILD'S WORLDWIDE TERMS AND CONDITIONS, SPECIFICALLY THE WARRANTY THEREIN, WHICH COVERS THESE PRODUCTS.

AUTHORIZED USE

Unless otherwise specified in this data sheet, this product is a standard commercial product and is not intended for use in applications that require extraordinary levels of quality and reliability. This product may not be used in the following applications, unless specifically approved in writing by a Fairchild officer: (1) automotive or other transportation, (2) military/aerospace, (3) any safety critical application – including life critical medical equipment – where the failure of the Fairchild product reasonably would be expected to result in personal injury, death or property damage. Customer's use of this product is subject to agreement of this Authorized Use policy. In the event of an unauthorized use of Fairchild's product, Fairchild accepts no liability in the event of product failure. In other respects, this product shall be subject to Fairchild's Worldwide Terms and Conditions of Sale, unless a separate agreement has been signed by both Parties.

ANTI-COUNTERFEITING POLICY

Fairchild Semiconductor Corporation's Anti-Counterfeiting Policy. Fairchild's Anti-Counterfeiting Policy is also stated on our external website, www.fairchildsemi.com, under Terms of Use

Counterfeiting of semiconductor parts is a growing problem in the industry. All manufacturers of semiconductor products are experiencing counterfeiting of their parts. Customers who inadvertently purchase counterfeit parts experience many problems such as loss of brand reputation, substandard performance, failed applications, and increased cost of production and manufacturing delays. Fairchild is taking strong measures to protect ourselves and our customers from the proliferation of counterfeit parts. Fairchild strongly encourages customers to purchase Fairchild parts either directly from Fairchild or from Authorized Fairchild Distributors who are listed by country on our web page cited above. Products customers buy either from Fairchild directly or from Authorized Fairchild Distributors are genuine parts, have full traceability, meet Fairchild's quality standards for handling and storage and provide access to Fairchild's full range of up-to-date technical and product information. Fairchild and our Authorized Distributors will stand behind all warranties and will appropriately address any warranty issues that may arise. Fairchild will not provide any warranty coverage or other assistance for parts bought from Unauthorized Sources. Fairchild is committed to combat this global problem and encourage our customers to do their part in stopping this practice by buying direct or from authorized distributors.

PRODUCT STATUS DEFINITIONS

Definition of Terms

Datasheet Identification	Product Status	Definition
Advance Information	Formative / In Design	Datasheet contains the design specifications for product development. Specifications may change in any manner without notice.
Preliminary	First Production	Datasheet contains preliminary data; supplementary data will be published at a later date. Fairchild Semiconductor reserves the right to make changes at any time without notice to improve design.
No Identification Needed	Full Production	Datasheet contains final specifications. Fairchild Semiconductor reserves the right to make changes at any time without notice to improve the design.
Obsolete	Not In Production	Datasheet contains specifications on a product that is discontinued by Fairchild Semiconductor. The datasheet is for reference information only.

Rev. I77