

VARIMETER

Speed Monitor

IK 9055, IL 9055, SK 9055, SL 9055

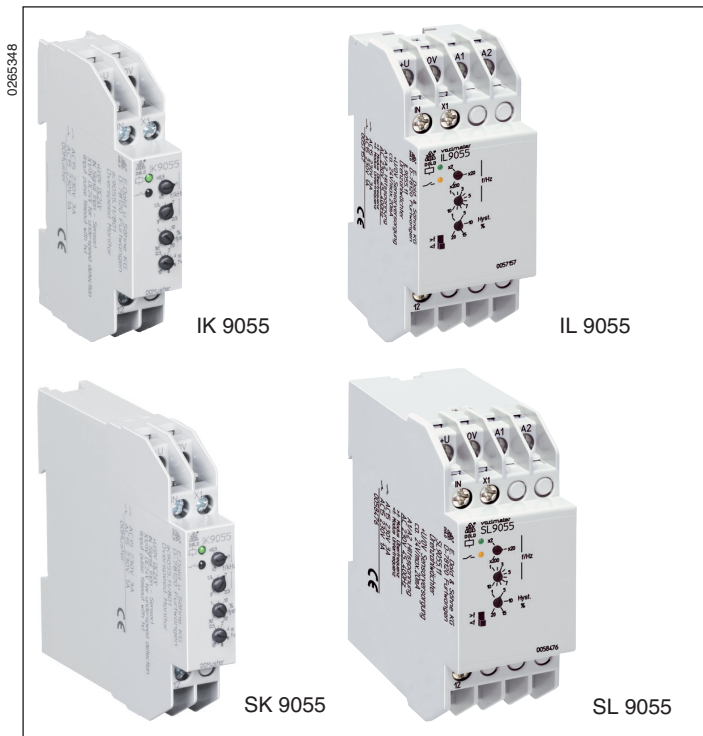

Your Advantage

- Protection of persons, machines and products
- Easy setting
- Universal input, for configuration of different sensors (PNP, NPN, 2-wire, contact, voltage)

Features

- According to IEC/EN 60 255-1
- Detection of over- or underspeed or frequency, function selectable
- 3 selectable ranges for frequency or speed, adjustable tripping value
- Ranges up to 10 kHz (\approx 600.000 ipm) available, therefore suitable for turbines, centrifuges and similar applications
- Adjustable hysteresis
- Input also suitable for SKF sensor bearings
- As option for Namur sensors
- As option for permanent magnet sensors
- As option with adjustable switching delay/start up delay
- On request with manual reset
- IK 9055 and SK 9055: compact version for DC 24 V auxiliary supply
- IL 9055 and SL 9055: for auxiliary supply up to AC 400 V with galvanic separation to sensor input
- De-energized on trip (Energized on trip on request)
- LED indicators for auxiliary supply, sensor pulses and contact position
- 1 changeover contact (2 changeover on request)
- Devices available in 2 enclosure versions:
 - IK/IL 9055: depth 59 mm, with terminals at the bottom for installation systems and industrial distribution systems according to DIN 43 880
 - SK/SL 9055: depth 98 mm, with terminals at the top for cabinets with mounting plate and cable duct
- DIN rail or screw mounting
- IK 9055, SK 9055: width 17.5 mm
- IL 9055, SL 9055: width 35 mm

Function Diagram

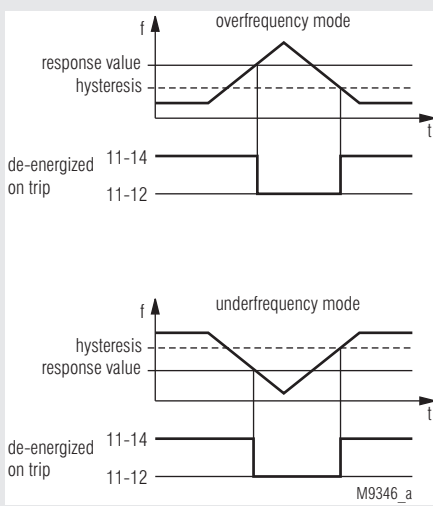

Approvals and Markings



Applications

Speed monitoring on rotating machine parts, monitoring of cyclic movements, general monitoring of pulse sequences (transportation, conveyors production systems), monitoring of pulse frequency (e.g. flow sensors, anemometers), pulse monitoring on railway rolling stock

Function

The frequency to be monitored is connected to the input terminal IN. It is compared to the adjusted tripping value.

In overfrequency mode, the output relay switches into alarm position when the preset response value is exceeded. When the system frequency once more falls below the response value minus the preset hysteresis, the output relay will switch back into normal position.

In underfrequency mode, the output relay switches into alarm position when the actual value falls below the preset response value. When the system frequency once more exceeds the response value plus hysteresis, the output relay will switch back into normal position.

If de-energized on trip is selected, the output relay is energized (11-14 closed) in normal status. If energized on trip is selected, the output relay is energized (11-14 closed) in alarm status.

Circuit Diagrams

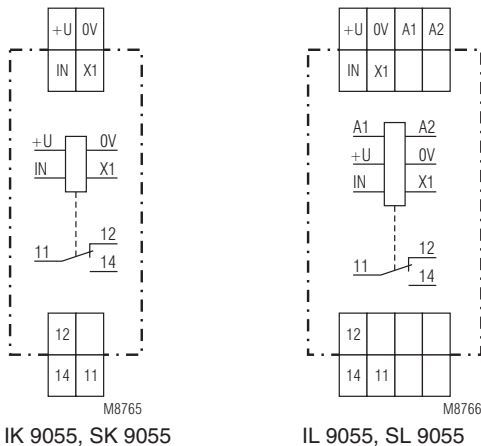

Connection Terminals

Terminal designation	Signal description
U+, 0V	Supply voltage device and sensor
A1, A2 (only at IL/SL)	Auxiliary voltage input
X1, IN	Connection sensor (see application example)
11, 12, 14	Changeover contact

Indicators

Green LED:	On, when only auxiliary voltage connected to A1-A2, intermittent red/green flashing when pulses are on the input IN
Yellow LED:	On, when the output relay is energized (contacts 11-14 closed)

Notes

To the universal input of the speed monitor (terminals +U, X1, IN, 0V) a wide range of different sensors can be connected (capacitive, inductive, ultrasonic, hall effect, optical, reed, etc.) The input is suitable for proximity sensors according to IEC/EN 60 947-5-2 (VDE 0660, part 208).

Depending on the type of sensor (3-wire PNP or NPN, 2-wire, contact, voltage) the connection is made to different terminals (see Connection Examples). The models IL and SL 9055 have a galvanic separation between Input Circuit (+U, X1, IN, 0V) and auxiliary supply (A1, A2 e.g. 230 V AC).

24 V DC with up to 20 mA is provided on the terminals U+/0V for the supply of the sensor.

If sensors with higher power consumption are used, the model IK and SK 9055 is suitable, where the sensors and the speed monitor are supplied by DC 24 V from an external power supply.

The speed monitors can be operated with SKF sensor bearings. Sensor bearings include ball bearing and speed sensor in a compact way. The actual sensors are hall effect sensors with NPN output. The connection is made as with NPN proximity sensors.

The model /200 is optimised for Namur proximity sensors according to IEC 60 947-5-6 (VDE 0660 part 212, previously EN 50 227/ DIN 19 234). Namur sensors are 2-wire sensors with defined current in on and off state.

The model /300 is designed to connect permanent magnet sensors. Permanent sensors are simple, robust 2-wire sensors without voltage supply and electronic circuits. They generate an induced voltage while the permanent magnet passes. They are very cost effective and can be used also with high temperature and hard ambient conditions.

Monitoring indicator of sensor input

The upper 2-coloure LED shows the connected supply voltage and the status of the sensor:

Green:	input IN on LOW level
Red:	input IN on HIGH level
Green/Red:	pulses on input IN

Several devices on one sensor

A parallel connection of several monitors to one sensor is possible without problems on the universal input, when several tripping values are required or a range between two limits should be monitored. The corresponding terminals are connected in parallel.

Monitoring function over- or underfrequency

The function can be changed by a slide switch on the front of the unit. Energized on trip or de-energized on trip remains the same when changing the function, also the tripping value remains unchanged. No calculations with hysteresis are necessary.

Hysteresis setting

When the setting value is very low in the lowest range, the hysteresis should not be adjusted to the minimum in order to avoid cycling of the output relay.

In the operating mode underfrequency (<f) at setting values near to the end of the range the hysteresis can only be set to 4 ... 10 % due to the internal circuit. When there are problems, the next higher range should be selected.

Reaction time

The unit work with an integrating measuring principle, where the mean value of several input pulse periods is calculated. This avoids problems with interference pulses, but the reaction time gets longer. The reaction time relates to the lowest adjustable frequency on the actual unit.

An approximate calculation is: Time constant (τ) $\approx \frac{2.5}{f_{\min}}$

The time constant (τ) is the time after which a change of the input frequency with 63 % influences the calculation. If the input frequency before the change is near to the switching value or the change of the frequency is very low, the reaction time can be shorter than the time constant. The technical data will show always the time constant.

Special models with shorter time constant (limited frequency range) on request.

Maximum input frequency, minimum pulse and space time

Every frequency measuring device detects input pulses only up to a certain maximum input frequency. (This is also a result of a proper interference suppression.) If the input frequency is higher than the maximum value, the input pulses are not longer detected. The monitor detects frequency 0.

The maximum frequency is always much higher than the maximum setting value of the highest setting range (see technical data).

Also the maximum switching frequency of the sensors must be observed. In addition every frequency input needs a certain minimum pulse and space duration of the connected sensor to react properly. This is very important with high frequency and a low or high pulse/space ratio (e.g. a small active area on big diameter or a small gap on big diameter at high rotation speed). If a frequency near to the maximum speed should be detected a pulse/space ratio of 1:1 should be provided by designing the rotating part accordingly. Pulse time is the time the high signal is present at the IN terminal, space time is the time the low signal is present on the IN terminal.

When using PNP sensors or contacts connected to +U the pulse time is identically with the on time of the sensor or contact.

The minimum pulse or space time are very short on these modules, so that most applications are uncritical (see technical data).

Variants with delay or start up delay

Devices with adjustable switching delay or start up delay can be made. The start up delay is started when connecting the auxiliary supply, during this time no frequency measurement is done. This may be useful in application for underspeed monitoring when the speed monitor is started up with the motor which needs some time to get on operation speed. Without start up delay there would be an alarm when before the motor is on speed. Compared with the standard switching delay a start up delay has the advantage that it only works one time on start up, but after that a change is detected immediately. If the start up delay is not required, (e.g. on function overspeed), the potentiometer "t/s" is set to left end (minimum).

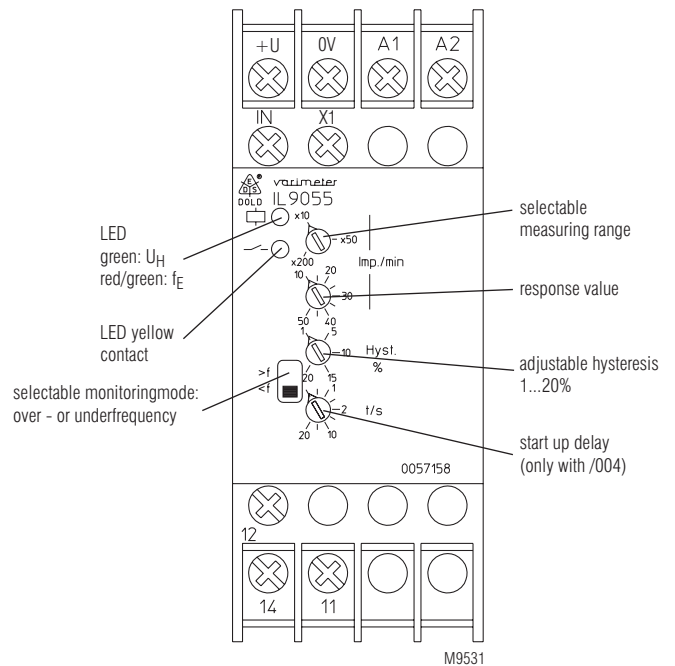

Technical Data**Input Circuit**

Universal input:	for PNP-, NPN-, 2-wire sensors, contacts and voltage suitable for proximity sensors according to IEC/EN 60 947-5-2 (VDE 0660 part 208)
IK 9055, SK 9055:	sensor supply by external auxiliary voltage DC 24 V
IL 9055, SL 9055:	built in power supply approx. DC 24 V, max. 20 mA
Max. residual current of 2-wire sensors:	2 mA (OFF)
Max. voltage drop of 2-wire sensors:	8 V (ON)
Voltage drive input resistance:	approx. 17 k Ω
Threshold Low	
IK 9055, SK 9055:	approx. 9.2 V
IL 9055, SL 9055:	approx. 8.4 V
Threshold High	
IK 9055, SK 9055:	approx. 11 V
IL 9055, SL 9055:	approx. 10.2 V

NAMUR Input

IK 9055/200, SK 9055/200, IL 9055/200, SL 9055/200: für NAMUR-sensors according to IEC/EN 60 947-5-6 (VDE 0660 part 212) (previously EN 50227/DIN 19234)

No-load operation voltage:	approx. 8.2 V
Input resistance:	1 k Ω
Short circuit current:	approx. 8 mA
Switching thresholds:	Low approx. 1.5 mA High approx. 1.8 mA

Input

IK 9055/300, SK 9055/300, IL 9055/300, SL 9055/300:	for permanent magnet sensors		
Input resistance at f < 100 Hz:	approx. 50 k Ω		
at f = 2 kHz:	approx. k Ω		
Input sensitivity standard:	approx. 50 mV _{eff.} (at f < 500 Hz)		
high:	approx. 20 mV _{eff.} (at f < 250 Hz)		
Max. input voltage:	80 V _{eff.}		
Monitoring mode:	overfrequency („>f“) or underfrequency („<f“) selectable via slide switch		
Response value:	frequency ranges each 3-fold, selectable via rotary switch		
Frequency range:			
100 ... 500	50 ... 500	2 ... 20	10 ... 100
500 ... 2500	500 ... 5000	20 ... 200	100 ... 1000
2000 ... 10000	5000 ... 50000	200 ... 2000	1000 ... 10000
Impulse/min	Impulse/min	Hz	Hz
Fineadjustment range:			
infinitely 1:5	infinitely 1:10	infinitely 1:10	infinitely 1:10
Max. Input frequency (Pulse: break = 1:1):			
5 kHz	5 kHz	5 kHz	15 kHz
Min. pulse- and breake time:			
150 μ s	150 μ s	150 μ s	50 μ s
Time constant τ measuring circuit:			
approx. 1.4 s	approx. 3 s	approx. 1.4 s	approx. 0.2 s
Hysteresis adjustable infinitely:	1... 20 % of the adjusted response		
	value		
Start up delay IK 9055/004, SK 9055/004, IL 9055/004, SL 9055/004 adjustable logarithmically:	0.1 ... 20 s		

Technical Data**Auxiliary Circuit**

IK 9055, SK 9055 (terminal connection +U/0V):	
Nominal voltage U_H:	DC 24 V
Voltage range:	19.2 ... 30 V
Nominal consumption:	max. approx. 0.5 W
IL 9055, SL 9055 (terminal connection A1/A2):	
Nominal voltage U_H:	AC 24 V, 48 V, 230 V (others on request)
Voltage range:	0.8 ... 1.1 U _H
Nominal consumption:	approx. 4 VA
Frequency range:	45 ... 400 Hz

Output

Contacts:	1 changeover contact
Thermal current I_{th}:	4 A
Switching capacity to AC 15	
NO contacts:	3 A / AC 230 V IEC/EN 60 947-5-1
NC contacts:	1 A / AC 230 V IEC/EN 60 947-5-1
nach DC 13	
NO contacts:	1 A / DC 24 V IEC/EN 60 947-5-1
NC contacts:	1 A / DC 24 V IEC/EN 60 947-5-1
Electrical life to AC 15 at 1 A / 230 V:	1.5 x 10 ⁶ switching cycles IEC/EN 60 947-5-1
Short circuit strength max. fuse rating:	4 A gG / gL IEC/EN 60 941-5-1
Mechanical life:	≥ 30 x 10 ⁶ switching cycles

General Data

Operating mode:	Continuous operation
Temperature range Operation:	- 20 ... + 60°C
Storage:	- 20 ... + 60°C
Altitude:	< 2,000 m
Clearance and creepage distances rated impulse voltage/pollution degree:	4 kV / 2 IEC 60 664-1
EMC Electrostatic discharge:	8 kV (air) IEC/EN 61 000-4-2
HF irradiation	
80 MHz ... 1 GHz:	20 V/m IEC/EN 61000-4-3
1 GHz ... 2 GHz:	10 V/m IEC/EN 61000-4-3
2 GHz ... 2.7 GHz:	1 V/m IEC/EN 61000-4-3
Fast transients:	4 kV IEC/EN 61 000-4-4
Surge voltage between wires for power supply:	1 kV IEC/EN 61 000-4-5
between wire and ground:	2 kV IEC/EN 61 000-4-5
HF-wire guided:	10 V IEC/EN 61 000-4-6
Interference suppression:	Limit value class B EN 55 011
Degree of protection Housing:	IP 40
Terminals:	IP 20 IEC/EN 60 529
Housing:	Thermoplastic with V0 behaviour according to UL subject 94
Vibration resistance:	Amplitude 0.35 mm, Frequency 10...55Hz, IEC/EN 60 068-2-6
Climate resistance:	20 / 060 / 04 IEC/EN 60 068-1
Terminal designation:	DIN EN 50 005
Wire connection:	DIN 46 228-1/-2/-3/-4
Cross section:	2 x 0.6 ... 2.5 mm ² solid or 2 x 0.28 ... 1.5 mm ² stranded wire with and without ferrules
Stripping length:	10 mm
Wire fixing:	Plus-Minus-terminal screws M3,5 with self-lifting clamping piece
Fixing torque:	0.8 Nm
Mounting:	DIN rail mounting (IEC/EN60715) or screw mounting M4, 90 mm hole pattern, with additional clip available as accessory

Technical Data

Weight

IK 9055:	approx. 65 g
SK 9055:	approx. 85 g
IL 9055:	approx. 140 g
SL 9055:	approx. 160 g

Dimensions

Width x height x depth

IK 9055:	17.5 x 90 x 59 mm
SK 9055:	17.5 x 90 x 98 mm
IL 9055:	35 x 90 x 59 mm
SL 9055:	35 x 90 x 98 mm

CSA-Data

Nominal voltage U_N :

IK 9055, SK 9055:	DC 24 V
IL 9055, SL 9055:	AC 24 V, AC 48 V, AC 230 V

Ambient temperature: -20 ... +60°C

Switching capacity: 3A 240Vac

Wire connection: 60°C / 75°C copper conductors only
AWG 20 - 14 Sol Torque 0.6 Nm
AWG 20 - 16 Str Torque 0.6 Nm



Technical data that is not stated in the CSA-Data, can be found in the technical data section.

Classification to DIN EN 50155 for IK 9055

Vibration and

shock resistance: Category 1, Class B IEC/EN 61 373

Ambient temperature: T1 compliant

T2, T3 and TX with operational limitations

Protective coating of the PCB: No

Standard Types

IK 9055.11/60 50 ... 50000 lpm U_H DC 24 V Hysteresis 1 ... 20 %
Article number: 0059786

- Universal input for PNP-, NPN-, 2-wire sensors, contacts, voltage
- Selectable function: over- or underfrequency
- 3-fold selectable ranges 50 ... 500 lpm, 500 ... 5000 lpm, 5000 ... 50000 lpm
- Response value infinitely adjustable 1:10
- Hysteresis adjustable: 1 ... 20 %
- Auxiliary voltage U_H : DC 24 V
- De-energized on trip
- Output: 1 changeover contact

IL 9055.11/60 2 ... 2000 Hz U_H AC 230 V Hysteresis 1 ... 20 %
Article number: 0057157

- Universal input for PNP-, NPN-, 2-wire sensors, contacts, voltage
- Selectable function: over- or underfrequency
- 3-fold selectable ranges 2 ... 20 Hz, 20 ... 200 Hz, 200 ... 2000 Hz
- Response value infinitely adjustable 1:10
- Hysteresis adjustable: 1 ... 20 %
- Auxiliary voltage U_H : AC 230 V
- De-energized on trip
- Output: 1 changeover contact

Variants

IK 9055.___/60,
SK 9055.___/60,
IL 9055.___/60,
SL 9055.___/60: with CSA-approval

IK 9055.11/004,
SK 9055.11/004,
IL 9055.11/004,
SL 9055.11/004: with adjustable start up delay
0.1 ... 20 s

IK 9055.11/200,
SK 9055.11/200,
IL 9055.11/200,
SL 9055.11/200: input for NAMUR sensors

IK 9055.11/300,
SK 9055.11/300,
IL 9055.11/300,
SL 9055.11/300: input for permanent magnet sensors

Application Example Universal Input

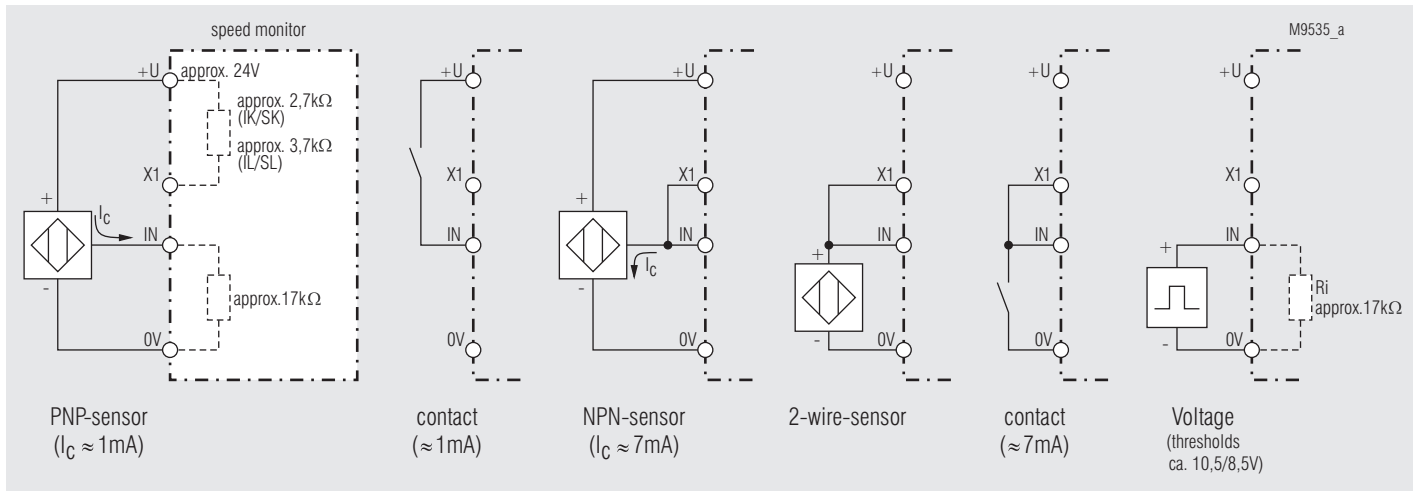

Note: For IK-models the auxiliary voltage (DC 24 V) must be additionally connected to terminals +U/0V

Initiators (proximity sensors), inductive

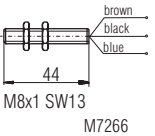
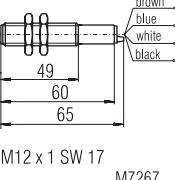
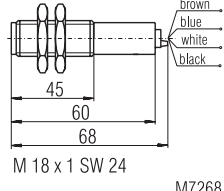
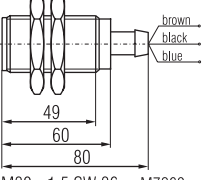
Type	NA 5001.01.10 pnp NA 5001.01.20 npn	NA 5002.01.34 pnp/npn	NA 5005.01.34 pnp/npn	NA 5010.01.10 pnp NA 5010.01.20 npn
Dimensions				
Enclosure	Metal	Metal	Metal	Metal
Switching distance S_n	1 mm	2 mm	5 mm	10 mm
Switching frequency	5 000 Hz	1 000 Hz	300 Hz	200 Hz
Hysteresis	2 ... 10 %			
Repeat accuracy	5 %			
Voltage range	10 ... 30 V			
Residual ripple	< 10 %			
Continuous current	≤ 200 mA	≤ 100 mA	≤ 100 mA	≤ 400 mA
Output	.10 pnp NO .20 npn NO	.34 pnp NO + npn NO	.34 pnp NO + npn NO	.10 pnp NO .20 npn NO
Indication of output state	LED			
Ambient temperature	- 25 ... 70°C			
Temperature influence	10 %			
Degree of protection	IP 67			
Connection wire	2 m			
Fixing torque	4 Nm	15 Nm	40 Nm	100 Nm
Weight	45 g	70 g	120 g	270 g

Connection Table IK 9055, SK 9055, IL 9055, SL 9055

Type	Wire	Terminal on IK / SK / IL / SL 9055
NA 5001.01.10	brown +	+ U
	blue -	0 V
	black NO	IN
NA 5002.01.34 NA 5005.01.34	brown +	+ U
	blanc +	+ U
	blue -	0 V
NA 5010.01.10	brown +	+ U
	blue -	0 V
	black NO	IN

Connection Table IK 9055, SK 9055, IL 9055, SL 9055

Type	Wire	Terminal on IK / SK / IL / SL 9055
NA 5001.01.20	brown +	+ U
	blue -	0 V
	black NO	IN, X1
NA 5002.01.34 NA 5005.01.34	brown +	+ U
	blanc NO	IN, X1
	blue -	0 V
	black -	0 V
NA 5010.01.20	brown +	+ U
	blue -	0 V
	black NO	IN, X1