



FEATURES

- Provides scaling of 0-5V and 0-10V process signals
- Operates from industrial 5V / 12V / 24V / 36V dc power supplies
- Fits round 1.21 inch [30.7 mm] cutouts; less than 1.00 inch [25.4 mm] behind-the-panel depth
- High input impedance, 100k Ω minimum
- Easy-to-read, 0.30 inch [7.6 mm] high red or green LED display
- Supplied with EPDM rubber gasket and hex nut
- High-quality, 20-turn, span (gain) and zero (offset) adjustments
- Gold-plated DIP-switches for range and decimal points: Reliable screw-terminal input connections
- Rugged, polycarbonate housing, one-piece package
- Protected against dust and water submersion to IP67/NEMA 6

Murata Power Solutions' new DMR20-0/5 Series are the world's first 0-5V input process monitors designed to fit industry standard, 1.21 inch [30.7 mm] round panel cutouts. Their large, easy-to-read, 0.30 inch [7.6 mm] digits are available in a choice of red or green LED displays. For the ultimate versatility in industrial applications, these new process monitors can be operated from any regulated source of 5V, 12V, 24V, or 36V dc power.

Gain (span) and offset (zero) adjustments are performed with on-board, precision, 20-turn potentiometers. All decimal-point and range-change selections are made on a 6-position, vibration-resistant, gold-plated DIP switch. Unlike competitive meters, there are no jumpers or solder gaps to open or close. To further enhance reliability, the entire assembly utilizes 100% soldered connections. Both power-supply and input-signal connections are made via a reliable, 3-position, screw-type terminal block.

The DMR20-0/5's DIP switch and potentiometers accommodate hundreds of input-voltage / output-reading combinations. This practically eliminates the need for more costly, long-lead-time, factory "customs" in applications which use several different-range meters. An EPDM rubber gasket and hex nut simplify installation and provide IP67 / NEMA 6 protection to environmental dirt and moisture, including water submersion to 3 feet (1 meter).

SIMPLIFIED SCHEMATIC DIAGRAM

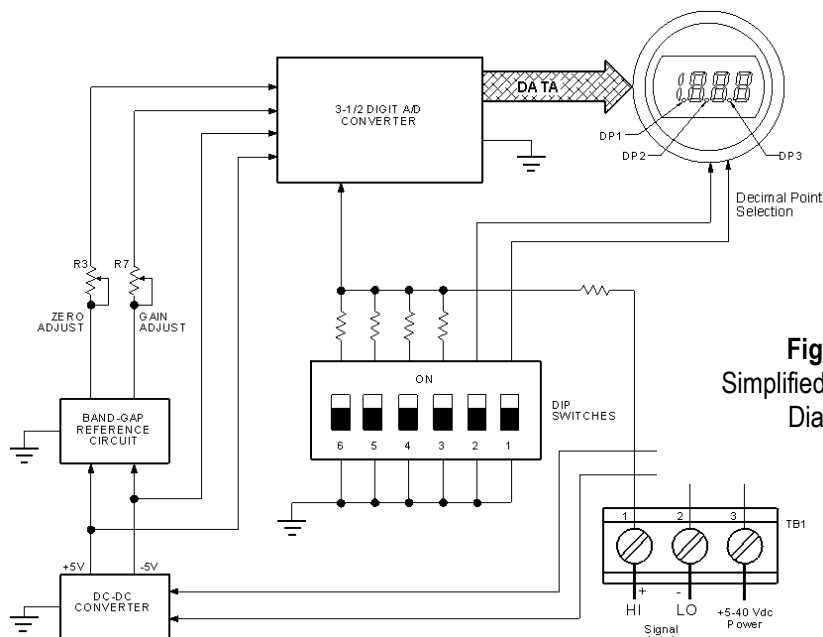

Figure 1
Simplified Schematic
Diagram



For full details go to:
<http://www.murata-ps.com/en/support/rohs-compliance.html>

Performance/Functional Specifications

Typical at T_A = +25°C, unless otherwise noted.

Input	Min.	Typ.	Max.	Units
Full Scale Input Range ①	4.9	5.0	5.1	Volts
Input Impedance	100	–	140	K Ω
Overvoltage Protection ②	–	–	±40	Volts
Performance				
Sampling Rate	2.5 reading per second			
Accuracy (1 minute warm-up):	±0.05% FS ±1 Count			
Temperature Drift (0 to +60°C)	–	±0.15	±0.3	Counts/°C
Power Supply Requirements				
DMR20-0/5-R-C (7.5 mA max.)	+5.0	–	+40.0	Volts
DMR20-0/5-G-C (10 mA max.)	+5.0	–	+40.0	Volts
Display				
Display Type and Size	3½ digit, 0.30" [7.6 mm] high LED			
Polarity Indication	"–" for negative V _{IN}			
Overrange Indication	"–1_ _ _" for negative inputs "1_ _ _" for positive inputs			
Physical/Environmental				
Operating Temperature	0	–	+60	°C
Storage Temperature	–20	–	+75	°C
Humidity (non-condensing)	0	–	85	%
Case Material	Polycarbonate			
Weight	0.65 ounces (18.5 grams)			

- ① The DMR20-0/5 can also be used in most 0-10V applications. See the section on 0-10V inputs for more information.
- ② INPUT LO (TB1-2) shares a common connection with power ground (also TB1-2). Overvoltage specifications apply to the INPUT HI (TB1-1) connection referenced to TB1-2.

Ordering Information

DMR20-0/5-R-C +5 to +50Vdc V Supply, Red LED's
DMR20-0/5-G-C +5 to +50Vdc V Supply, Green LED's

Note: An M30 x 1.5 nylon metric hex nut and EPDM sealing gasket are supplied with each meter. The "–C" suffix indicates RoHS compliance

Panel Knockout Tools:

DMR20-1-KP 1.22" [30.9 mm] punch (no keying notch)
DMR20-2-KP 1.21" [30.7 mm] punch with 4 keying notches
DMR20-3-KP Keyway Punch tool

TECHNICAL NOTES

1. Input Configuration: The DMR20-0/5 has its signal input LO terminal connected to its power supply ground terminal (TB1-2). This connection effectively places the meter's input in a single-ended configuration, that is, signal ground is connected directly to power ground. In some applications, single-ended inputs may cause ground-loop induced errors (the meter's display becomes unstable).

Applications which require electrical isolation between the input signal ground and the system power supply ground must use a separate transformer-isolated supply to power the meter.

2. Panel Mounting: In most standard through-the-panel installations, the DMR20-0/5 must be secured to the panel with the supplied M30 x 1.5 metric nut and gasket, see the Mechanical Specifications section for more information.

OPERATING AND SETUP INSTRUCTIONS

As shipped, the DMR20-0/5 is factory calibrated to read "000" for a 0.0 V input and "1900" for a 5.0 V input. The following worst-case procedure assumes the DMR20-0/5 is completely miss-adjusted, i.e., both potentiometers and the DIP switches are randomly set.

- Set R7 (full scale span/gain adjust) fully counterclockwise, and R3 (zero/offset adjust) fully clockwise, roughly 22 turns, and place SW3-SW6 to OFF (down position).
- Select DIP switch setting #1 in Table 1.
- Apply a precision 0.0 V input and adjust R3 until the meter's display reads "000."
- Apply a precision 5.0 V input and adjust R7 until the meter's display reads "1900." Repeat steps 3 and 4 to make sure the adjustments do not affect one another.
- Select the appropriate decimal point by setting SW and SW2 per Table 3.

NOTE: The "000" to "1900" display readings referred to in the instructions above are for instructional purposes only. If other display readings are desired, refer to DIP-Switch Settings Tables 1 and 2 for SW3-SW6 settings. The initial setting of R3 fully clockwise and R7 fully counterclockwise is recommended in the adjustment procedure for all the following examples.

0-5 V Inputs

Examples (0-5V Inputs)

- Desired display readings are: 0.0 V input = "0.00"
5.0 V input = "6.00"

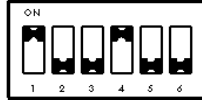

Use DIP-switch setting #3 in Table 1 and enable decimal point DP2 by setting SW1 to ON and SW2 to OFF. Apply 0.0 V and adjust R3 so the display reads "0.00." Apply 5.0 V and adjust R7 so the display reads "6.00."

- Desired display readings are: 0.0 V input = "000"
5.0 V input = "800"

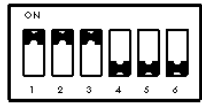

Use DIP-switch setting #2 in Table 1. Apply 0.0 V and adjust R3 so the display reads "000." Apply 5.0 V and adjust R7 so the display reads "800." For these display readings, no decimal points are used, so set SW1 and SW2 both to ON.

- Desired display readings are: 0.0 V input = "000"
5.0 V input = "250"

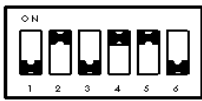

Use DIP-switch setting #5 in Table 1 and enable decimal point DP1 by setting SW1 to OFF and SW2 to ON. Apply 0.0 V and adjust R3 so the display reads "000." Apply 5.0 V and adjust R7 so the display reads "250."

- Desired display readings are: 1.0 V input = "000"
6.0 V input = "090"

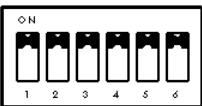

Even though this input is positioned between +1.0 V and +6.0 V, it still meets the 5V full scale differential input range listed in the Functional Specifications section. Use DIP-switch setting #8 in Table 1. Apply 1.0 V and adjust R3 so the display reads "090". With this type of input, it is advisable to recheck both input levels to be sure the potentiometer settings did not affect one another.

Table 1

0-5V DIP-Switch Settings ③

	0.0 V Input	5.0 V Input	SW3	SW4	SW5	SW6
1	000	to 1200-1999	Off	Off	Off	Off
2	000	to 700-1200	On	Off	Off	Off
3	000	to 400-700	Off	On	Off	Off
4	000	to 300-400	Off	Off	On	Off
5	000	to 190-300	Off	On	On	Off
6	000	to 120-190	Off	Off	On	On
7	000	to 100-150	Off	On	On	On
8	000	to 90-140	On	On	On	On

0-10 V Inputs

While the DMR20-0/5 is optimized for operation with 0-5V inputs, its versatile input stage can also accommodate most 0-10V applications. The meter's zero/offset potentiometer (R3) has enough adjustment range to produce a "000" display reading with input signal levels between -0.1 V and +1.0 V. Table 2 summarizes the available ranges when the DMR20-0/5 is used with 0-10V inputs.

Example (0-10V Inputs)

- Desired display readings are:
0.0 V input = "000"
10.0 V input = "500"

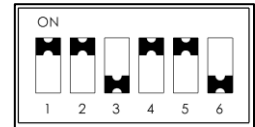

Use DIP switch setting #4 in Table 2. Apply 0.0 V and adjust R3 so the display reads "000." Apply 10.0 V and adjust R7 so the display reads "500."

Table 2

0-10 V DIP-Switch Setting

	0.0 V Input	10.0 V Input	SW3	SW4	SW5	SW6
1	000	to 1400-1999	On	Off	Off	Off
2	000	to 800-1400	Off	On	Off	Off
3	000	to 600-800	Off	Off	On	Off
4	000	to 380-600	Off	On	On	Off
5	000	to 240-380	Off	Off	On	On
6	000	to 200-300	Off	On	On	On
7	000	to 180-280	On	On	On	On

Table 3

Decimal Point Settings (All Models)

SW1	SW2	Decimal Point
Off	Off	DP3
On	Off	DP2
Off	On	DP1
On	On	None

③The DMR20-0/5 is optimized for 0/5 V process input signals that range between -0.1 V and +6.0 V. As such, input signal ranges can be anywhere between -0.1 V and +6.0 V or between +1.0 V and +6.0 V, as long as the differential value is 5.0 Volts. The meter's zero/offset potentiometer (R3) has enough adjustment range to produce a "000" display reading for zero input signal levels between -0.1 V and +1.0 V. As noted earlier, most 0-10 V inputs can also be accommodated as indicated in Table 2.

CONNECTION DIAGRAM

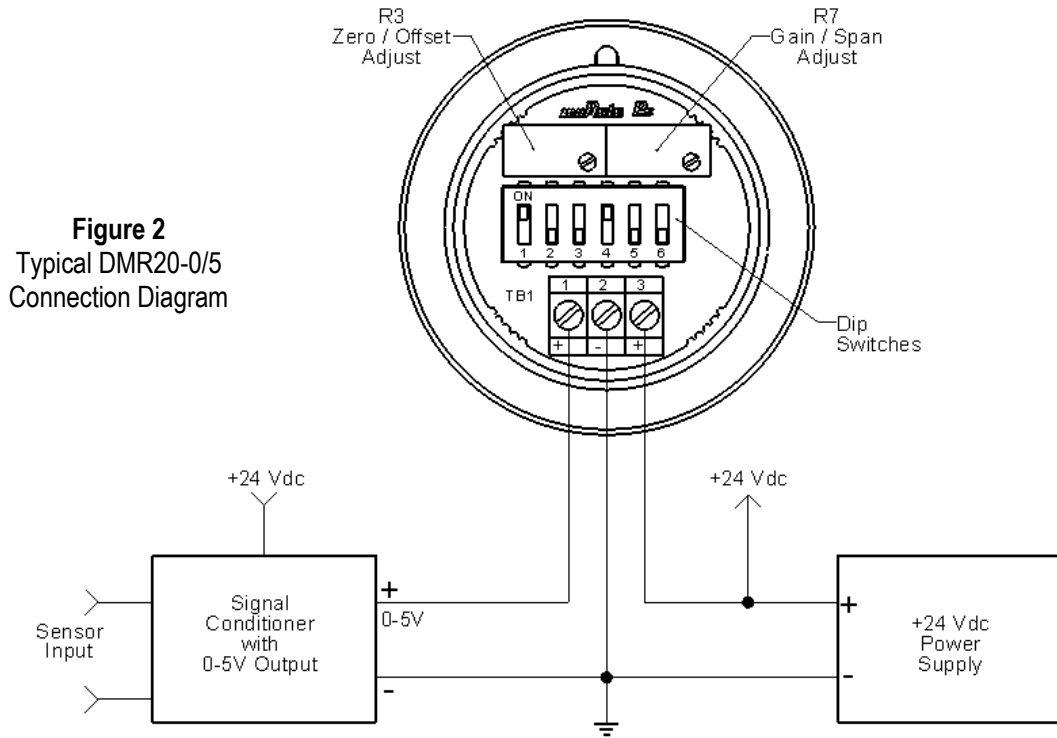

Figure 2
 Typical DMR20-0/5
 Connection Diagram

INSTALLATION DIAGRAM

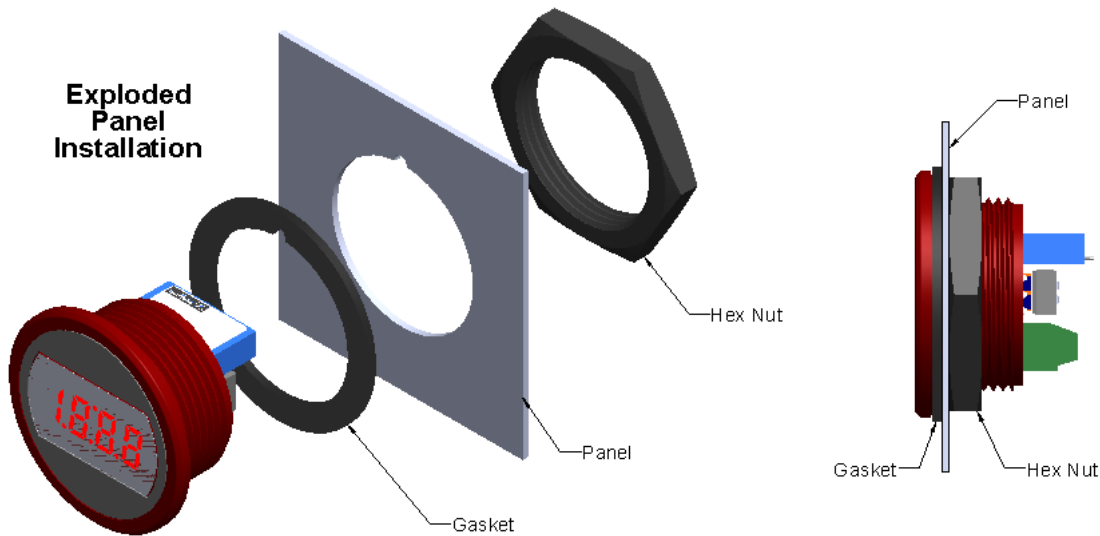
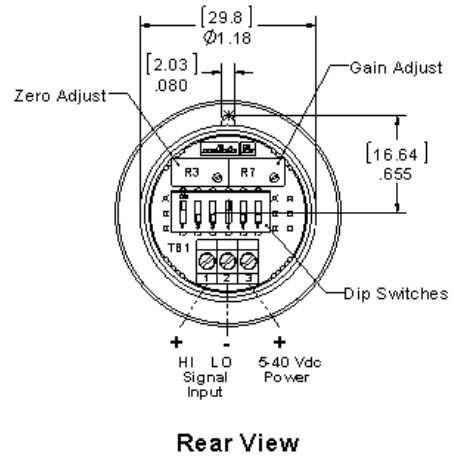
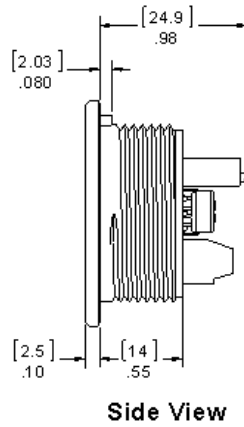
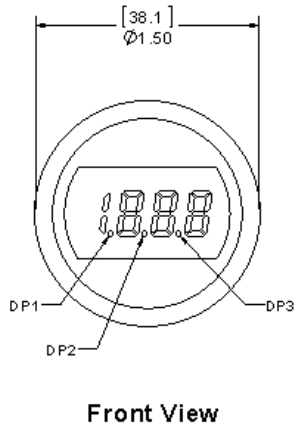
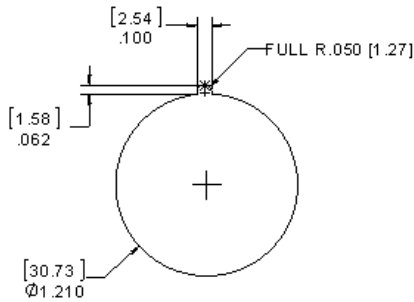

Figure 3
 Panel Installation

MECHANICAL SPECIFICATIONS AND RECOMMENDED PANEL CUTOUT



Mechanical Outline



UNLESS OTHERWISE SPECIFIED:

Dimensions are in Inches [mm]

Tolerances:

.XX ±.02 [0.5]

.XXX ±.010 [.25]

Angles: ±2°

Components are shown for Reference Only

3D Models are available at:

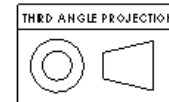

<http://www.murata-ps.com/en/3d/meters.html>

Available Panel Knockout Tools:

DMR20-1-KP	1.22" [30.9 mm] punch (no keying notch)
DMR20-2-KP	1.21" [30.7 mm] punch with 4 keying notches
DMR20-3-KP	Keyway Punch tool

TB1 Recommended Wire Terminations:

WIRE SIZE: 18 to 26 AWG (Solid or stranded)
STRIPPING LENGTH: 0.20" [5.1 mm] Nominal

Murata Power Solutions, Inc.
11 Cabot Boulevard, Mansfield, MA 02048-1151 U.S.A.
ISO 9001 and 14001 REGISTERED



This product is subject to the following operating requirements and the Life and Safety Critical Application Sales Policy:

Refer to: <http://www.murata-ps.com/requirements/>

Murata Power Solutions, Inc. makes no representation that the use of its products in the circuits described herein, or the use of other technical information contained herein, will not infringe upon existing or future patent rights. The descriptions contained herein do not imply the granting of licenses to make, use, or sell equipment constructed in accordance therewith. Specifications are subject to change without notice.
© 2015 Murata Power Solutions, Inc.