

REVISIONS			
REV.	DESCRIPTION	DATE	APPROVED
A	ECO #6393	10/10/06	A.D.M.

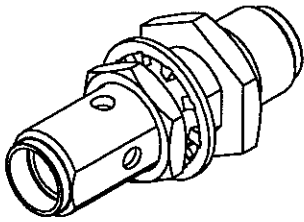

PROPRIETARY INFORMATION
NOT TO BE RELEASED
WITHOUT WRITTEN PERMISSION
FROM AN AUTHORIZED
REPRESENTATIVE OF
APPLIED ENGINEERING PRODUCTS

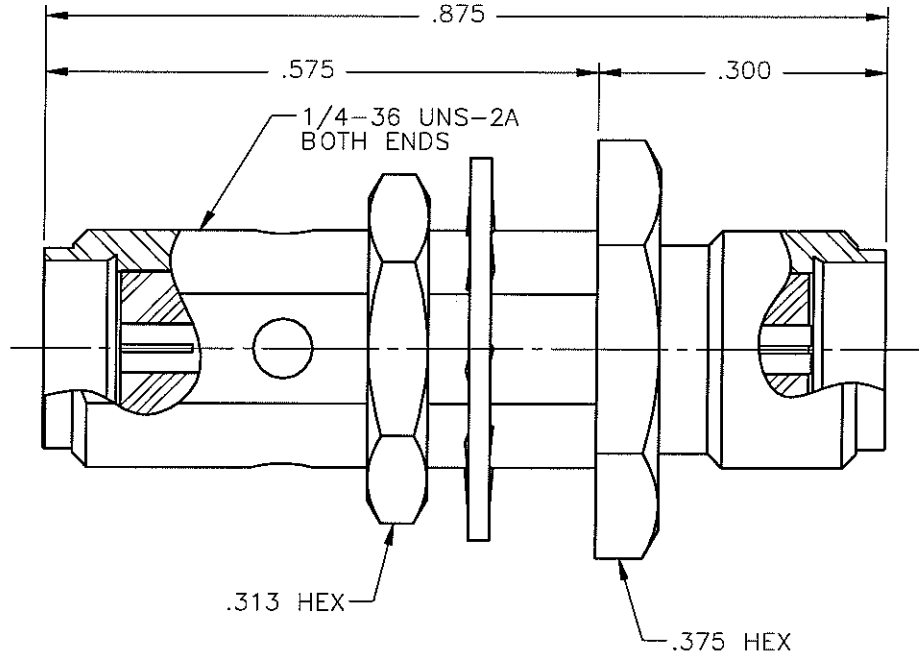
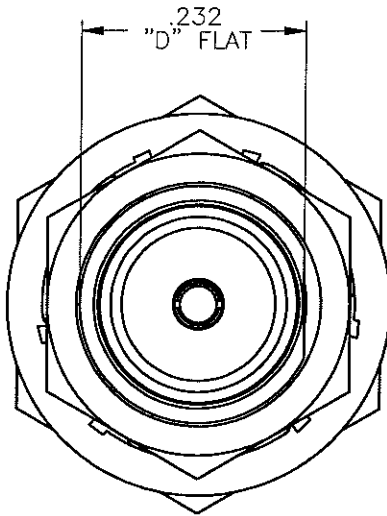

NOTES: CONFORMS TO MIL-C-39012 SMA SERIES

MATERIALS:

1. BODY & NUT = STAINLESS STEEL PER ASTM A582, ALLOY 303, CONDITION "A".
2. INSULATOR = VIRGIN WHITE TEFLON PER ASTM D1710, GRADE 1, TYPE I, CLASS "B".
3. CONTACT = BERYLLIUM COPPER PER ASTM B196, ALLOY C17300, TEMPER TD04.
4. LOCKWASHER = PHOSPHOR BRONZE PER ASTM B139, COPPER ALLOY C53400, TEMPER H04.

FINISHES:

1. BODY & NUT = GOLD PLATE PER MIL-G-45204, TYPE II, CLASS 0, GRADE C; OVER .000050 TO .00010 STRESS FREE NICKEL PER QQ-N-290.
2. CONTACT = GOLD PLATE PER MIL-G-45204, TYPE II, CLASS 1, GRADE C, OVER .00010 TO .00020 STRESS FREE SULFAMATE NICKEL PER QQ-N-290.
3. LOCKWASHER = GOLD PLATE PER MIL-G-45204, TYPE II, CLASS 0, GRADE C, OVER .00010 TO .00020 COPPER STRIKE PER MIL-C-14550.

UNLESS OTHERWISE SPECIFIED DIMENSIONS ARE IN INCHES TOLERANCES ON		DWN: A.D.M.	DATE 10/10/06	 APPLIED ENGINEERING PRODUCTS 104 John W. Murphy Dr. New Haven, CT 06513 a RADIALL company			
		CHKD: D.N.	DATE 10/10/06				
DECIMAL	ANGLE	APVD: B.N.	DATE 10/10/06	SMA STRAIGHT BULKHEAD MOUNT JACK TO JACK ADAPTOR			
REFERENCE:		MATERIALS & FINISHES: SEE NOTES					
ORIGINATED: D.N. DATE: 09/20/90				SCALE 5:1	THIRD ANGLE PROJECTION		SHEET 1 OF 1

5909-1103-000

Mouser Electronics

Authorized Distributor

Click to View Pricing, Inventory, Delivery & Lifecycle Information:

Radial:

[5909-1103-000](#)