

USBR-B-S-F-O-TH

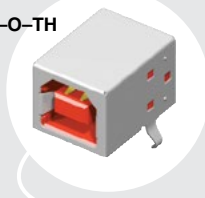

USB-B-S-S-B-SM



USB-B, USBR-B SERIES

STANDARD & RUGGED USB 2.0

SPECIFICATIONS

For complete specifications and recommended PCB layouts see www.samtec.com?USB-B or www.samtec.com?USBR-B

Insulator Material:

High Temperature Thermoplastic

Contact Material:

Phosphor Bronze

Plating:

Gold on Contacts, Nickel on Shell, Tin on Tails

Operating Temp Range:

-50 °C to +85 °C

Voltage Rating:

30 VAC

Cycles:

1500 (maximum number of cycles tested)

Packaging:

Packaged and shipped in Bulk Packaging Trays; Trays suitable for automation are available upon request.

RoHS Compliant:

Yes

Lead-Free Solderable:

USB-SM=Yes

USB-TH= Yes

(Wave Solder only)

USBR=Yes (Wave Solder only)

TID Number:

USB-B-S-X-X-TH (61001155)

RUGGEDIZED
BY SAMTEC

- High retention option

Minimum 15N withdrawal force

Increased retention option

Through-hole option

RECOGNITIONS

For complete scope of recognitions see www.samtec.com/quality



TYPE	B	S	PLATING	COLOR	TERMINATION	OTHER OPTION
USB = Standard Connector			-F = Gold Flash on Mating Area, Tin on Tails	-B = Black (USB only)	-TH = Through-hole	-TR = Tape and Reel Packaging (-SM only)
USBR = Increased Retention Connector (Complies with Class 1, DIV II minimum withdrawal requirement of 15N)			-S = 30 μ" (0.76 μm) Gold on Mating Area, Tin on Tails	-W = White (USB only)	-SM = Surface Mount (USB only)	-FR = Full Reel Tape & Reel (must order maximum quantity per reel; contact Samtec for quantity breaks) (-SM only)
				-O = Orange (USBR only)	-VT = Vertical Top Entry	

MATING / UNMATING FORCE (100 CYCLES)		
SERIES	MATING	UNMATING
USB	5.3 (23.59 N)	6.1 (27.15 N)
USBR	11.8 (52.51 N)	11.5 (51.18 N)

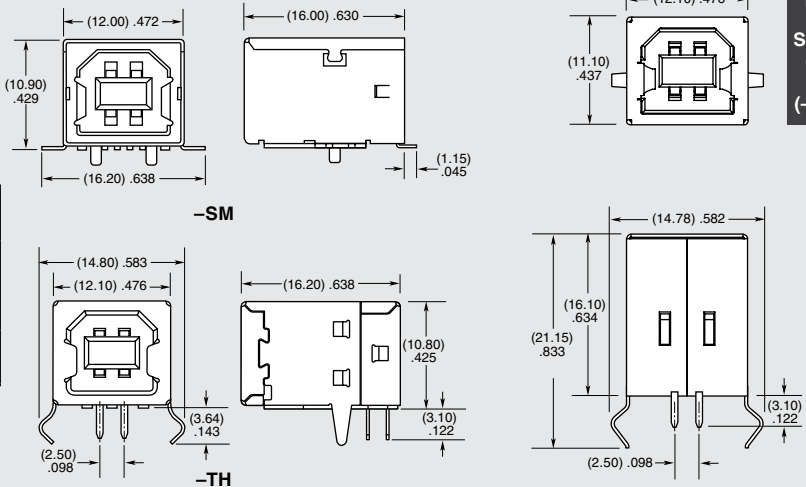

Due to technical progress, all designs, specifications and components are subject to change without notice.

WWW.SAMTEC.COM