

RECOMMENDED PCB LAYOUT TOP VIEW (TOLERANCE:±0.05)  
RECOMMENDED METAL MASK T=0.12MM

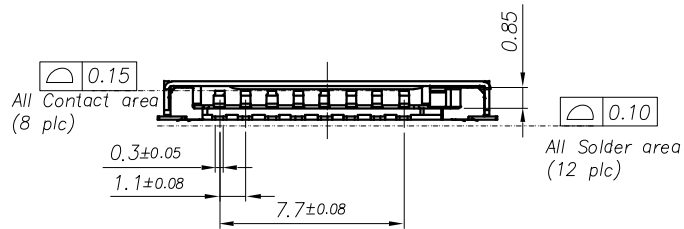
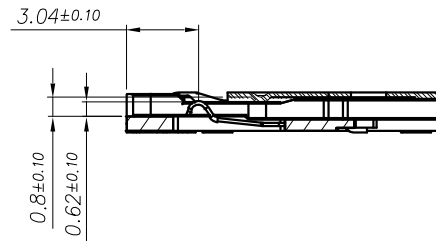

MICRO SD CARD

PIN NO.	NAME	TYPE	DESCRIPTION
P1	DAT 2	I/O/PP	DATE LINE(BIT 2)
P2	CD/DAT 3	I/O/PP	CARD DETECT DATE LINE(BIT3)
P3	CMD	PP	COMMAND RESPONSE
P4	VDD	S	SUPPLY VOLTAGE
P5	CLK	I	CLOCK
P6	VSS	S	
P7	DAT 0	I/O/PP	DATE LINE(BIT 0)
P8	DAT 1	I/O/PP	DATE LINE(BIT 1)

-NOTES-

- VOLTAGE RATING :100V AC/DC
- CURRENT RATING:0.5A MAX
- CONTACT RESISTANCE:100 mohm MAX/1001mA
- INSULATION RESISTANCE:1000M ohms MIN/500VDC
- DIELECTRIC WITHSTANDING VOLTAGE:500VAC/MINUTE
- OPERATING TEMPERATURE:-30°C TO +80°C
- STORAGE TEMPERATURE:-40°C TO +70°C
- RETENTION FORCE:MIN.100gf/PIN
- DURABILITY:1,000 CYCLES
- 1000pcs/reel

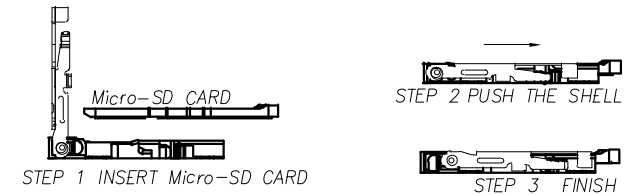

UNLESS OTHERWISE SPECIFIED TOLERANCE				东莞市讯普电子科技有限公司 www.xunpudianzi.com	
UNIT:	DECIMAL	LINEAR	ANGLES		
mm	X.	±0.50	±5°		
	X.X	±0.25	±3°		
	X.XX	±0.12	±1°		
DRAWN	Fros	2014/12/12	DRAWN NAME:		
CHECKED	Ron	2014/12/12	TF CONNECTOR		
APPROVED	Albert	2014/12/12	PRODUCT NO.	TF-102-15	
SCALE 3.2		SHEET 1/2	SIZE A4		

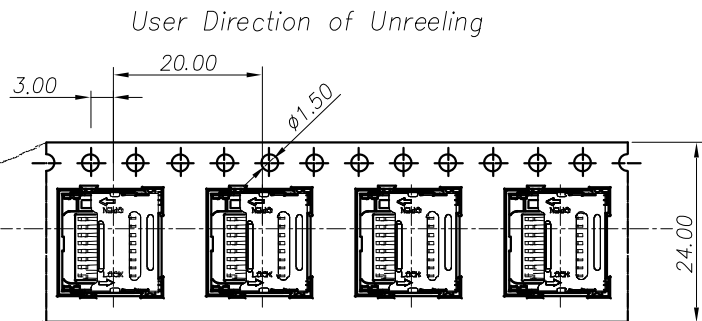

NOTES

1. NUMBER OF CONNECTORS: 1000PCS/REEL
2. LEAD TAPE LENGTH

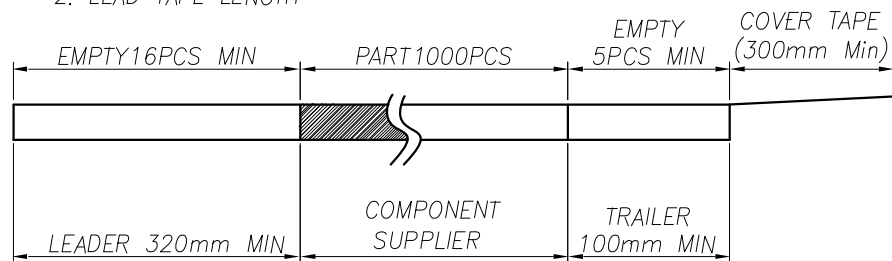

3. QUANTITY: 10,000PCS/CARTON

4. WEIGHT :

3.1 NET WEIGHT : 2.4Kg

3.2 GROSS WEIGHT : 6.5Kg

COVER TAPE PEELING ANGLE: 165°~180°  
PEELING FORCE: 20~130g

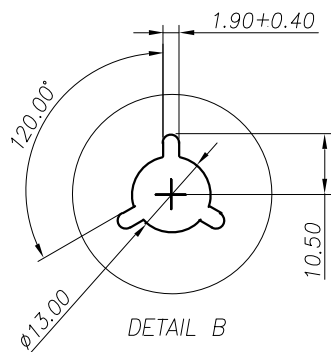
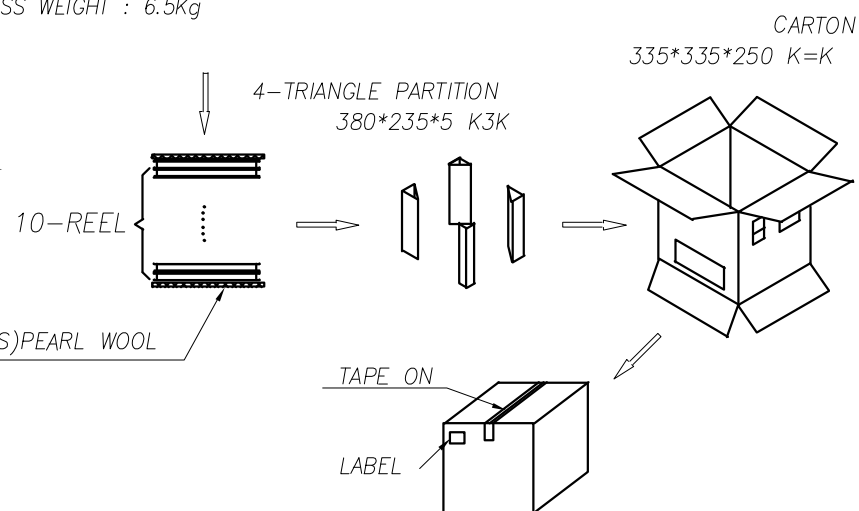
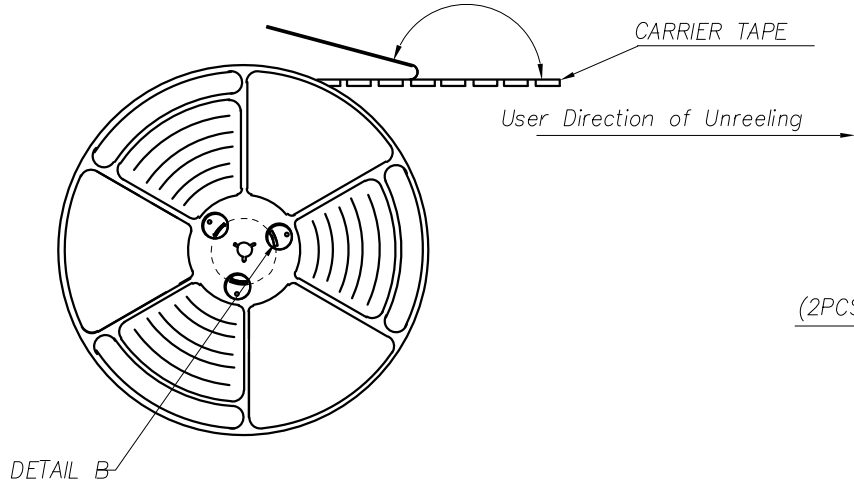
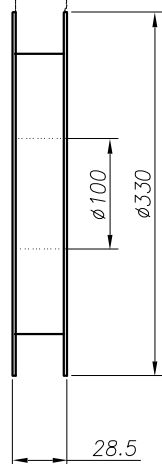

1	TF-102-15	1000	10	10000
ITEM	PRODUCT NO.	PCS/REEL	REEL/CARTON	PCS/CARTON

UNLESS OTHERWISE SPECIFIED TOLERANCE				东莞市讯普电子科技有限公司 www.xunpudianzi.com
UNIT:	DECIMAL	LINEAR	ANGLES	
mm	X.	±0.50	±5°	
	X.X	±0.25	±3°	
	X.XX	±0.12	±1°	
DRAWN	Fros	2014/12/12	DRAWN NAME:	
CHECKED	Ron	2014/12/12	TF CONNECTOR	
APPROVED	Albert	2014/12/12	PRODUCT NO.	TF-102-15
SCALE	3.2	SHEET 2/2	SIZE	A4