

ABIDE BY ROHS

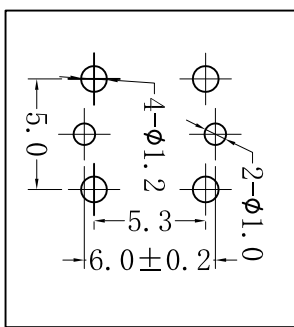

PCB Layout Recommended

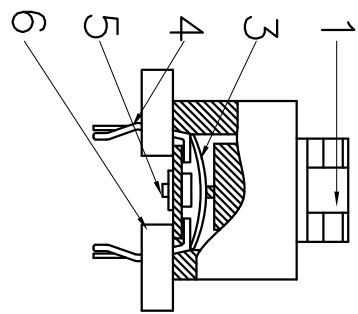
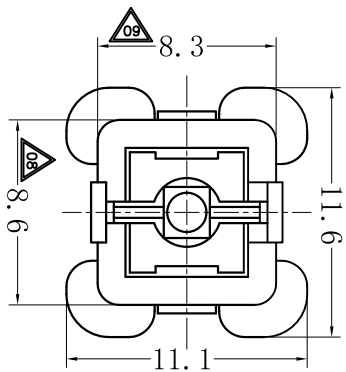
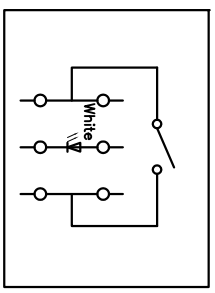
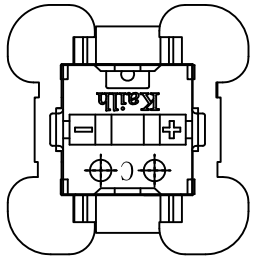
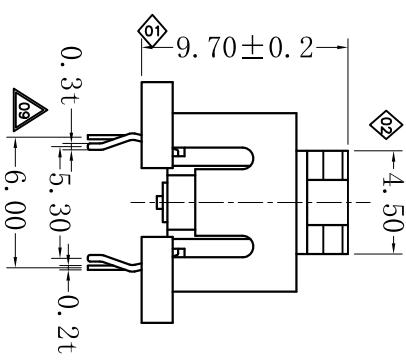
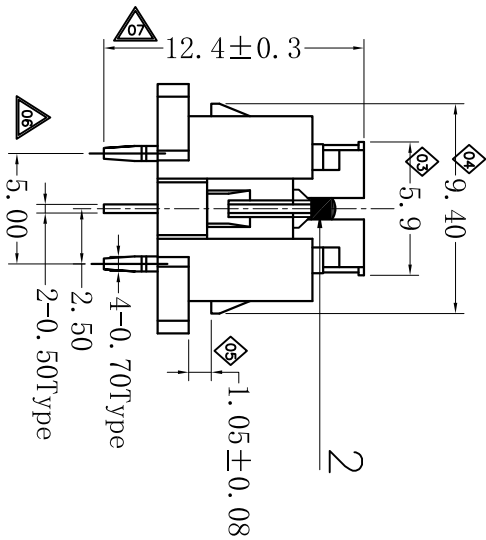
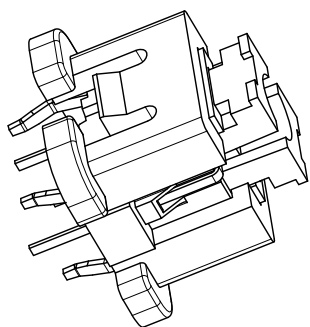

Circuit Diagram

Switch Specification :

- 1.Rating Switch : DC12V 50mA
- 2.Contact Resistance :100mΩ Max00MΩ Min
- 3.Insulation Resistance :
- 4.Withstand Voltage :
- 5.Operation Force : 150±50gf
- 6.Life Test : 100,000 Cycles
- 7.Total Travel : 0.25±0.1mm

6	Holder	1pcs	PC	Grey	
5	Base	1pcs	PBT	Black	
4	Terminal	4pcs	Brass	Plating silver	
3	Contact	1pcs	Copper Silver	Plating silver	
2	LED	1pcs	φ1.8mm super bright White LED		
1	Keystoke	1pcs	POM	White	

APPROVALS	DATE	TITLE:	LAMP SWITCH
DRAWN	Tanghuihui 2013.9.21	Kaihua	东莞市凯华电子有限公司 KAIHUA ELECTRONICS CO.,LTD
CHECKED		PART NO.	CLA117201D01
APPROVALS			

ECN NO.	REV.	DATE.	DESCRIPTION.	CHANGE.	CHECK.	APPRO.	TOLERANCES ARE	30<L	±0.30	ANGLE	UNIT: mm	SCALE:	PROJ	SHEET
	A		NEW				10<L	±0.20	±2°	mm			1 OF 1	
							5<L	±0.15						
							≤5	±0.10						