



**TV-10/TV-15 rated  
1a 30A, 2a 25A  
power relays**

# HE RELAYS

### Protective construction

- Dust cover type : Plug-in, TM and Screw terminal types
- Flux-resistant type : PC board type

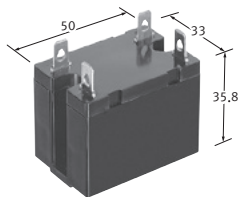

1 Form A Plug-in type

(Unit : mm)

## FEATURES

### 1. Excellent resistance to contact welding

Owing to the pre-tension and kick-off mechanism, the 1 Form A passes TV-15 and the 2 Form A passes TV-10.

### 2. High-capacity and long life

Contact arrangement	1 Form A type	2 Form A type
Contact capacity	30A	25A
Electrical life (at 20 times/min.)	2×10 <sup>5</sup>	
Mechanical life (at 180 times/min.)	DC type: 10 <sup>7</sup> , AC type: 5×10 <sup>6</sup>	

### 3. Excellent surge resistance

Between contacts and coil, the surge voltage is more than 10,000 V (when surge waveform accords with JEC-212-1981).

### 4. Compatible with all major safety standards

UL, CSA, VDE and TÜV certified

### 5. Terminals are available

## TYPICAL APPLICATIONS

### 1. Office equipment

Copiers, package air conditioners, automatic vending machines.

### 2. Industrial equipment

Machine tools, molding equipment, wrapping machines, food processing equipment, etc.

### 3. Home appliances

Water heaters and air heating equipment.

Type	Single side stable type HE 1 Form A, 2 Form A	
Insulation gap	Min. 8 mm	
Distance between contacts*	Plug-in, TM and Screw terminal types: Min. 3 mm .118 inch	PC board type: Min. 2.5 mm .098 inch
Breakdown voltage	Between open contacts	2,000 Vrms for 1 min.
	Between contact and coil	5,000 Vrms for 1 min.

\* Reference value

## CLASSIFICATION

Type	PC board	Plug-in		TM		Screw terminal	
Operating function	Single side stable						
Contact arrangement	1 Form A	1 Form A	2 Form A	1 Form A	2 Form A	1 Form A	2 Form A

## ORDERING INFORMATION

**HE** □ □ - □ □

### • Contact arrangement

- 1a : 1 Form A (Single side stable type)
- 2a : 2 Form A (Single side stable type)

### • Operate voltage

- N : 70% of nominal voltage

### • Terminal shape

- Nil : Plug-in type
- S : Screw terminal type
- Q : TM type
- P : PC board type

### • Nominal coil voltage

- DC : 6, 12, 24, 48, 100, 110V
- AC : 12, 24, 48, 100(100/120), 200(200/240)V

## TYPES

### 1. PC board type (1 Form A, DC coil) (Single side stable type)

Nominal coil voltage	1 Form A	
	Part No.	
6V DC	HE1aN-P-DC6V	
12V DC	HE1aN-P-DC12V	
24V DC	HE1aN-P-DC24V	
48V DC	HE1aN-P-DC48V	
100V DC	HE1aN-P-DC100V	
110V DC	HE1aN-P-DC110V	

Standard packing: Carton: 25 pcs.; Case: 100 pcs.

### 2. Plug-in type (Single side stable type)

Type	Nominal coil voltage	1 Form A		2 Form A	
		Part No.		Part No.	
DC type	6V DC	HE1aN-DC6V	HE2aN-DC6V		
	12V DC	HE1aN-DC12V	HE2aN-DC12V		
	24V DC	HE1aN-DC24V	HE2aN-DC24V		
	48V DC	HE1aN-DC48V	HE2aN-DC48V		
	100V DC	HE1aN-DC100V	HE2aN-DC100V		
	110V DC	HE1aN-DC110V	HE2aN-DC110V		
AC type	12V AC	HE1aN-AC12V	HE2aN-AC12V		
	24V AC	HE1aN-AC24V	HE2aN-AC24V		
	48V AC	HE1aN-AC48V	HE2aN-AC48V		
	100/120V AC	HE1aN-AC100V	HE2aN-AC100V		
	200/240V AC	HE1aN-AC200V	HE2aN-AC200V		

Standard packing: Carton: 20 pcs.; Case: 100 pcs.

### 3. TM type (Single side stable type)

Type	Nominal coil voltage	1 Form A		2 Form A	
		Part No.		Part No.	
DC type	6V DC	HE1aN-Q-DC6V	HE2aN-Q-DC6V		
	12V DC	HE1aN-Q-DC12V	HE2aN-Q-DC12V		
	24V DC	HE1aN-Q-DC24V	HE2aN-Q-DC24V		
	48V DC	HE1aN-Q-DC48V	HE2aN-Q-DC48V		
	100V DC	HE1aN-Q-DC100V	HE2aN-Q-DC100V		
	110V DC	HE1aN-Q-DC110V	HE2aN-Q-DC110V		
AC type	12V AC	HE1aN-Q-AC12V	HE2aN-Q-AC12V		
	24V AC	HE1aN-Q-AC24V	HE2aN-Q-AC24V		
	48V AC	HE1aN-Q-AC48V	HE2aN-Q-AC48V		
	100/120V AC	HE1aN-Q-AC100V	HE2aN-Q-AC100V		
	200/240V AC	HE1aN-Q-AC200V	HE2aN-Q-AC200V		

Standard packing: Carton: 20 pcs.; Case: 100 pcs.

### 4. Screw terminal type (Single side stable type)

Type	Nominal coil voltage	1 Form A		2 Form A	
		Part No.		Part No.	
DC type	6V DC	HE1aN-S-DC6V	HE2aN-S-DC6V		
	12V DC	HE1aN-S-DC12V	HE2aN-S-DC12V		
	24V DC	HE1aN-S-DC24V	HE2aN-S-DC24V		
	48V DC	HE1aN-S-DC48V	HE2aN-S-DC48V		
	100V DC	HE1aN-S-DC100V	HE2aN-S-DC100V		
	110V DC	HE1aN-S-DC110V	HE2aN-S-DC110V		
AC type	12V AC	HE1aN-S-AC12V	HE2aN-S-AC12V		
	24V AC	HE1aN-S-AC24V	HE2aN-S-AC24V		
	48V AC	HE1aN-S-AC48V	HE2aN-S-AC48V		
	100/120V AC	HE1aN-S-AC100V	HE2aN-S-AC100V		
	200/240V AC	HE1aN-S-AC200V	HE2aN-S-AC200V		

Standard packing: Carton: 10 pcs.; Case: 50 pcs.

Note: The TM type of the screw terminals are also available.

\* Terminal sockets available.

## RATING

### 1. Coil data

- Operating characteristics such as 'Operate voltage' and 'Release voltage' are influenced by mounting conditions, ambient temperature, etc. Therefore, please use the relay within  $\pm 5\%$  of rated coil voltage.
- 'Initial' means the condition of products at the time of delivery.

#### 1) AC coils

Nominal coil voltage	Pick-up voltage (at 20°C 68°F)	Drop-out voltage (at 20°C 68°F)	Nominal operating current [ $\pm 10\%$ ] (at 20°C 68°F)	Nominal operating power	Max. applied voltage (at 20°C 68°F)
12V AC	70%V or less of nominal voltage (Initial)	15%V or more of nominal voltage (Initial)	138mA	1.7VA	110%V of nominal voltage
24V AC			74mA	1.8VA	
48V AC			39mA	1.9VA	
100/120V AC			18.7 to 2.1mA	1.9 to 2.7VA	
200/240V AC			9.1 to 10.8mA	1.8 to 2.6VA	

#### 2) DC coils

Nominal coil voltage	Pick-up voltage (at 20°C 68°F)	Drop-out voltage (at 20°C 68°F)	Nominal operating current [ $\pm 10\%$ ] (at 20°C 68°F)	Coil resistance [ $\pm 10\%$ ] (at 20°C 68°F)	Nominal operating power	Max. applied voltage (at 55°C 131°F)
6V DC	70%V or less of nominal voltage (Initial)	10%V or more of nominal voltage (Initial)	320mA	18.8 $\Omega$	1.92W	110%V of nominal voltage
12V DC			160mA	75 $\Omega$	1.92W	
24V DC			80mA	300 $\Omega$	1.92W	
48V DC			40mA	1,200 $\Omega$	1.92W	
100V DC			19mA	5,200 $\Omega$	1.92W	
110V DC			18mA	6,300 $\Omega$	1.92W	

## 2. Specifications

Characteristics	Item	Specifications	
Contact	Contact material	AgSnO <sub>2</sub> type	
	Arrangement	1 Form A   2 Form A	
	Contact resistance (Initial)	Max. 100 m $\Omega$ (By voltage drop 6 V DC 1A)	
Rating	Nominal switching capacity (resistive load)	30A 277V AC   25A 277V AC	
	Max. switching power	8,310VA   6,925VA	
	Max. switching voltage	277V AC, 30V DC	
	Max. switching current	30A   25A	
	Nominal operating power	DC: 1.92W, AC: 1.7 to 2.7VA	
	Min. switching capacity (Reference value)*1	100mA 5V DC	
Electrical characteristics	Insulation resistance (Initial)	Min. 1,000M $\Omega$ (at 500V DC) Measurement at same location as "Breakdown voltage" section.	
	Breakdown voltage (Initial)	Between open contacts	2,000 Vrms for 1min (Detection current: 10mA.)
		Between contact sets	—   4,000 Vrms for 1min (Detection current: 10mA.)
		Between contact and coil	5,000 Vrms for 1min (Detection current: 10mA.)
	Surge breakdown voltage*2 (between contact and coil) (Initial)	Min. 10,000V	
	Operate time (at nominal voltage) (Initial)	Max. 30ms (excluding contact bounce time)	
Release time (at nominal voltage) (Initial)	DC: Max. 10ms (excluding contact bounce time, without diode), AC: Max. 30ms (excluding contact bounce time)		
Mechanical characteristics	Shock resistance	Functional	Min. 98 m/s <sup>2</sup> (Half-wave pulse of sine wave: 11 ms; detection time: 10 $\mu$ s.)
		Destructive	Min. 980 m/s <sup>2</sup> (Half-wave pulse of sine wave: 6 ms.)
	Vibration resistance	Functional	10 to 55 Hz at double amplitude of 1 mm (Detection time: 10 $\mu$ s.)
		Destructive	10 to 55 Hz at double amplitude of 1.5 mm
Expected life	Mechanical	DC: Min. 10 <sup>7</sup> (at 180 times/min.), AC: Min. 5 $\times$ 10 <sup>6</sup> (at 180 times/min.)	
	Electrical (resistive load) (at 20 times/min.)	Min. 2 $\times$ 10 <sup>5</sup> (30A 250V AC)   Min. 10 <sup>5</sup> (25A 277V AC)   Min. 2 $\times$ 10 <sup>5</sup> (20A 250V AC)	
Conditions	Conditions for operation, transport and storage*3	Ambient temperature: -50°C to +55°C -58°F to +131°F Humidity: 5 to 85% R.H. (Not freezing and condensing at low temperature), Air pressure: 86 to 106kPa	
	Max. operating speed	20 times/min. (at max. rating)	
Unit weight		PC board type: approx. 80g 2.82oz, Plug-in type/TM type: approx. 90g 3.17oz, Screw terminal type: approx. 120g 4.23oz	

Notes: \*1. This value can change due to the switching frequency, environmental conditions, and desired reliability level, therefore it is recommended to check this with the actual load.

\*2. Wave is standard shock voltage of  $\pm 1.2 \times 50\mu$ s according to JEC-212-1981

\*3. The upper limit of the ambient temperature is the maximum temperature that can satisfy the coil temperature rise value. Refer to Usage, transport and storage conditions in NOTES.

# REFERENCE DATA

## 1 Form A Type

### 1. Maximum switching power

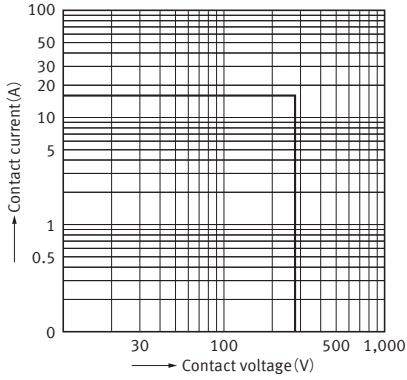

### 2. Life curve

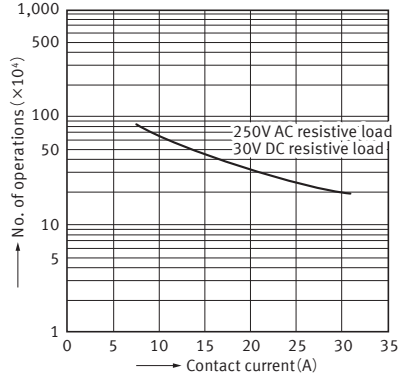

### 3. Coil temperature rise (DC type)

Measured portion : Coil inside  
Contact current : 30A

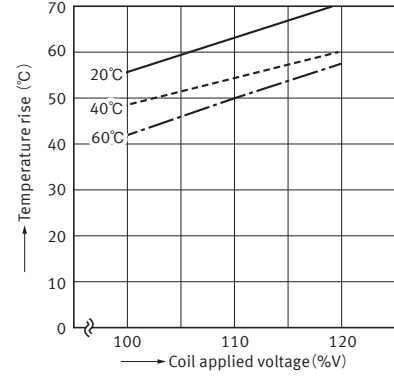

## 4. Ambient temperature characteristics

Tested sample : HE1aN-120V AC, 6pcs.

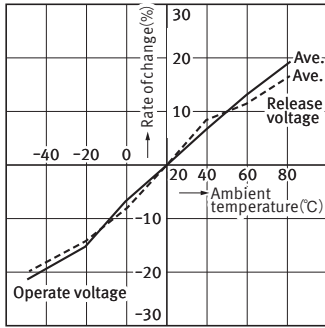

## 2 Form A Type

### 1. Maximum switching power

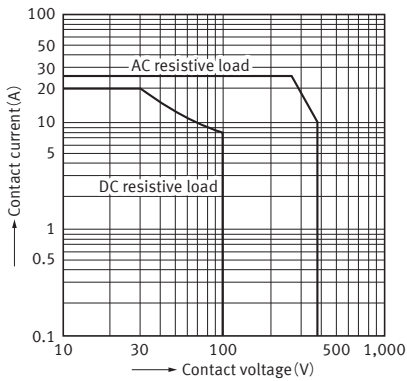

### 2. Life curve

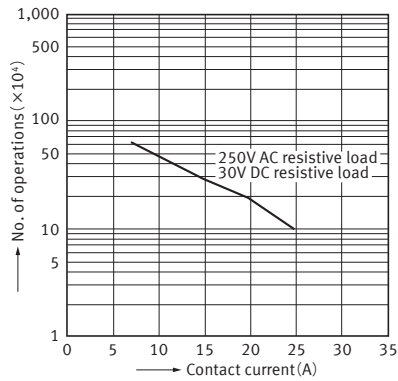

### 3. Coil temperature rise (DC type)

Measured portion : Coil inside  
Contact current : 25A

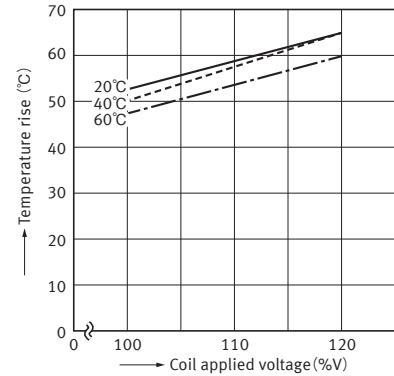

## 4. Ambient temperature characteristics

Tested sample : HE2aN-120V AC, 6 pcs.

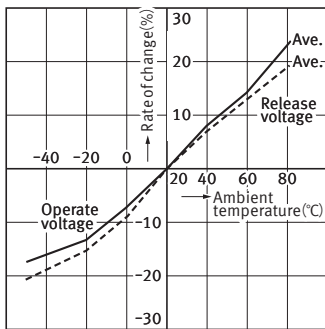

# DIMENSIONS (mm)

## 1. PC board type

1 Form A

**CAD**

External dimensions  
Single side stable type

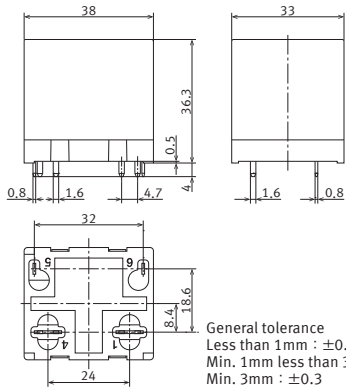

**CAD** The CAD data of the products with a "CAD" mark can be downloaded from our Website.

Schematic (Bottom view)  
Single side stable type

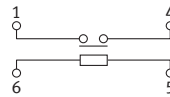

PC board pattern (Bottom view)

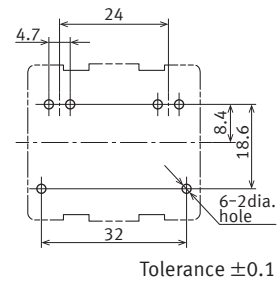

## 2. Plug-in type

1 Form A

**CAD**

External dimensions  
Single side stable type

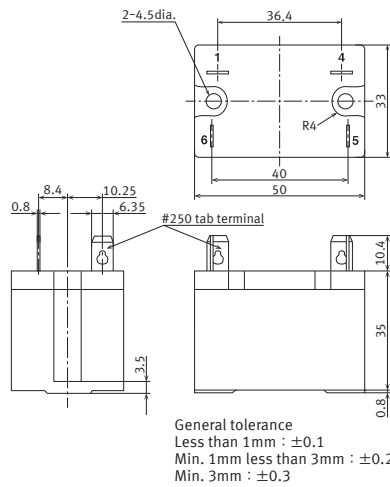

Schematic (Bottom view)  
Single side stable type

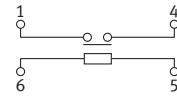

Panel cutout

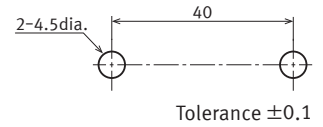

## 2 Form A

**CAD**

External dimensions  
Single side stable type

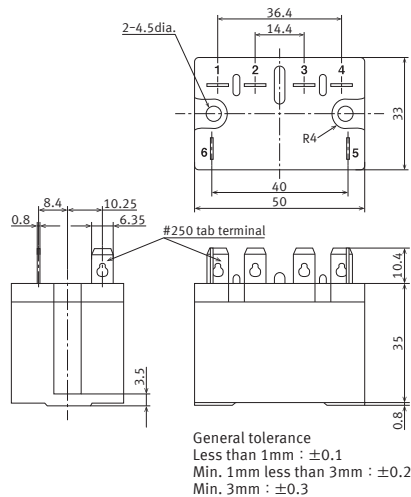

Schematic (Bottom view)  
Single side stable type

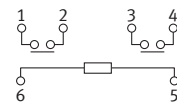

Panel cutout

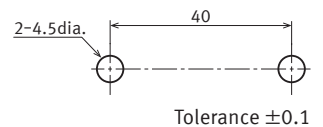

3. TM type  
CAD

External dimensions  
Single side stable type

Schematic (Bottom view)  
Single side stable type

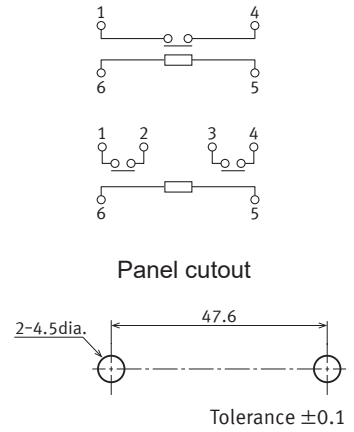
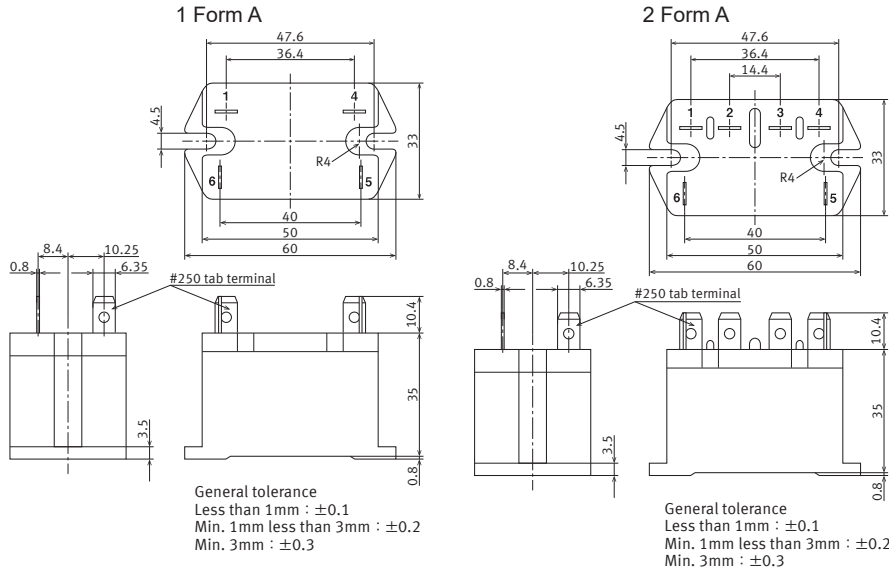

4. Screw terminal type  
1 Form A  
CAD

External dimensions  
Single side stable type

Schematic (Bottom view)  
Single side stable type

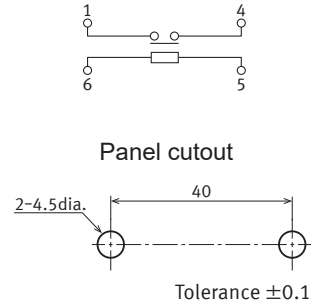
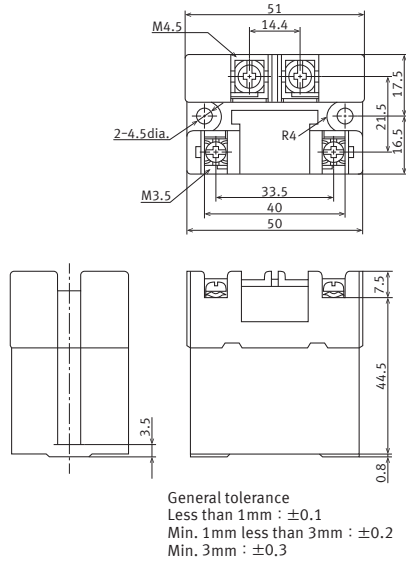

2 Form A  
CAD

External dimensions  
Single side stable type

Schematic (Bottom view)  
Single side stable type

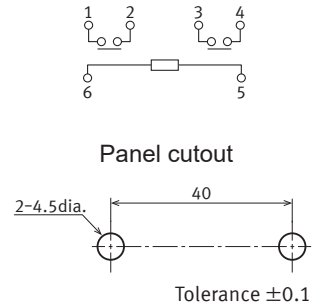
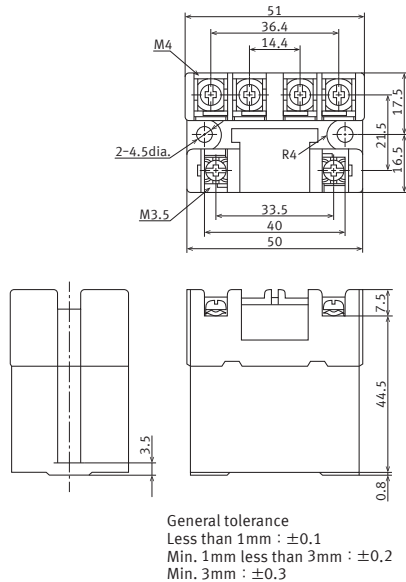

## MOUNTING METHOD

### 1. Plug-in type

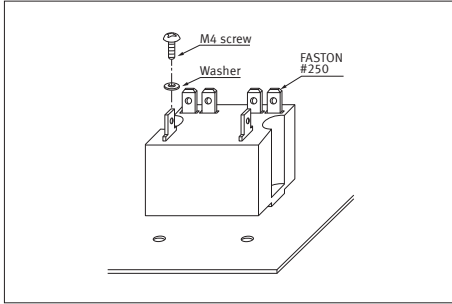

### 2. Screw terminal type

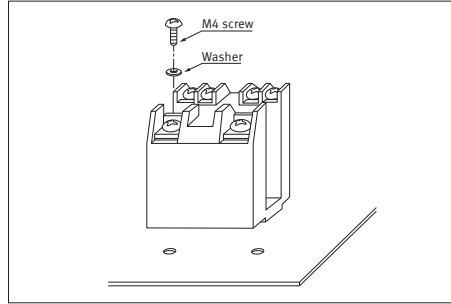

### 3. Allowable installation wiring size for screw terminal types and terminal sockets

Due to the UP terminals, it is possible to either directly connect the wires or use crimped terminal.

## SAFETY STANDARDS

Item	UL (Recognized)			CSA (Certified)		VDE (Certified)*		TÜV (Certified)			TV rating (UL/CSA)			
	File No.	Contact rating	Cycles	File No.	Contact rating	File No.	Contact rating	File No.	Rating	Cycles	File No.	Rating		
1 FormA	E43028	30A 277V AC	10 <sup>5</sup>	LR26550	30A 277V AC	40006681	30A 250V AC (cosφ =1.0)	B 11 04 13461 293	30A 250V AC (cosφ =1.0)	10 <sup>5</sup>	UL: E43028	TV-15		
		30A 30V DC	10 <sup>5</sup>		30A 30V DC		30A 250V AC (cosφ =0.4)		10 <sup>5</sup>	CSA: LR26550			TV-15	
		1.5HP 125V AC	10 <sup>5</sup>		1.5HP 125V AC		5A 110V DC (0ms)		8A 110V DC (0ms)	10 <sup>5</sup>			—	—
		3HP 250V AC	10 <sup>5</sup>		3HP 250V AC		—		—	—			—	—
2 FormA	E43028	25A 277V AC	10 <sup>5</sup>	LR26550	25A 277V AC	40006681	25A 250V AC (cosφ =1.0)	B 11 04 13461 293	25A 250V AC (cosφ =1.0)	10 <sup>5</sup>	UL: E43028	TV-10		
		25A 30V DC	10 <sup>5</sup>		25A 30V DC		25A 250V AC (cosφ =0.4)		10 <sup>5</sup>	CSA: LR26550			TV-10	
		1HP 125V AC	10 <sup>5</sup>		1HP 125V AC		5A 110V DC (0ms)		8A 110V DC (0ms)	10 <sup>5</sup>			—	—
		2HP 250V AC	10 <sup>5</sup>		2HP 250V AC		—		—	—			—	—

\*VDE: Approved for products having a different last digit of Part No. Please contact us.

## NOTES

- For cautions for use, please read "GENERAL APPLICATION GUIDELINES".
- The dust cover should not be removed since doing so may alter the characteristics.
- Avoid use under severe environmental conditions, such as high humidity, organic gas or in dust, oily locations and locations subjected to extremely frequent shock or vibrations.
- When mounting, use spring washers. Optimum fastening torque ranges from 49 to 68.6 N·m (5 to 7 kgf·cm).
- Firmly insert the receptacles so that there is no slack or looseness. To remove a receptacle, 19.6 to 39.2 N (2 to 4 kg) of pulling strength is required. Do not remove more than one receptacle at one time. Always remove one receptacle at a time and pull it straight outwards.
- When using the AC type, the operate time due to the in-rush phase is 20 ms or more. Therefore, it is necessary for you to verify the characteristics for your actual circuit.
- When using the push-on blocks for the screw terminal type, use crimped terminals and tighten the screw-down terminals to the torque below.  
M4.5 screw: 147 to 166.6 N·cm (15 to 17 kgf·cm)  
M4 screw: 117.6 to 137 N·cm (12 to 14 kgf·cm)  
M3.5 screw: 78.4 to 98 N·cm (8 to 10 kgf·cm)

Please refer to "the latest product specifications"

when designing your product.

• Requests to customers :

<https://industrial.panasonic.com/ac/e/salespolicies/>

# ACCESSORIES

## HE RELAYS TERMINAL SOCKETS

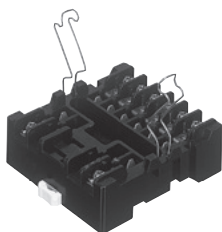

### FEATURES

- 1. Snap-in mounting to DIN rails is possible**  
Can be inserted into 35 mm 1.378 inch wide DIN rails. Removal is easy, too.
- 2. Sure and easy wiring**  
The use of UP terminals makes wiring exceptionally easy and sure.
- 3. Hold-down clips can be stored in main unit**  
Because the hold-down clips can be stored in the main unit, there is no need to remove them when, for example, wiring is changed.

### TYPES

No. of poles	Types	Part No.
For 1 Form A	Single side stable type	JH1-SF
For 2 Form A	Single side stable type	JH2-SF

Standard packing: Carton: 10 pcs.; Case: 50 pcs.

### SPECIFICATIONS

Item	Specifications	
	1 Form A	2 Form A
Arrangement	1 Form A	2 Form A
Max. continuous current	30A 250V AC	20A 250V AC
Breakdown voltage (initial)	2,000 Vrms for 1min (between terminals) (Detection current: 10mA.)	
Insulation resistance	Min. 100MΩ (between poles)	
Heat resistance	150°C ±3°C 302°F ±37.4°F for 1 hour	

Note: Do not insert or remove while powered on.

### DIMENSIONS (mm)

1 Form A and 2 Form A types

**CAD** The CAD data of the products with a "CAD" mark can be downloaded from our Website.

**CAD**

External dimensions

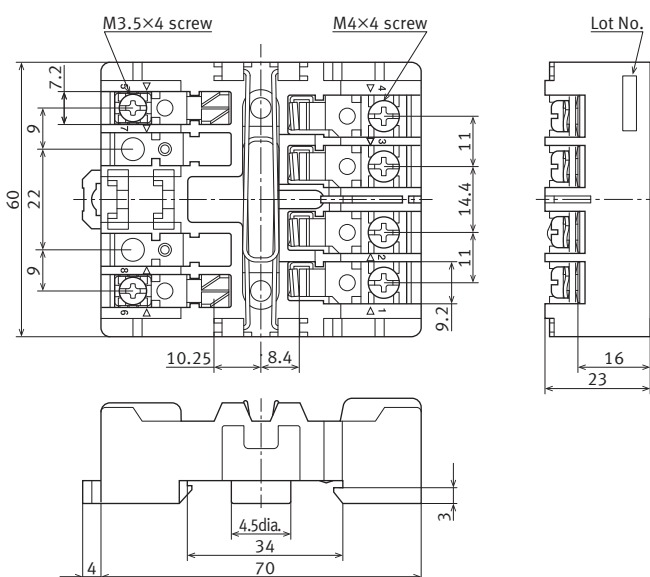

Panel cutout

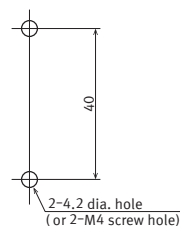

Relay mounting diagram

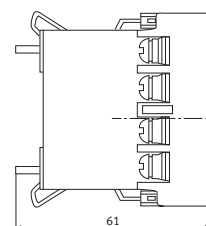

Note: The JH1-SF(1 Form A single side stable type) does not have receptacles (tooth rests) for numbers 2, 3, 7, and 8.  
The JH2-SF(2 Form A single side stable type) does not have receptacles (tooth rests) for numbers 7 and 8.



## MOUNTING METHOD

### 1. Relay mounting

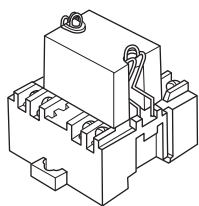

### 2. Installing to a DIN rail

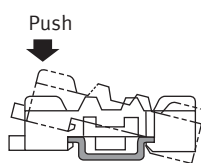

### 3. Removing from a DIN rail

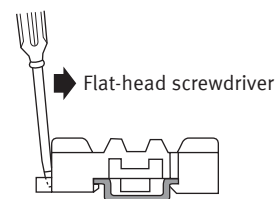

## NOTES

1. Be careful not to drop the relay. It is made of heat-hardened resin and may break.
2. Be sure to tighten the screw-down terminals firmly. Loose terminals may lead to the generation of heat.
3. When the 1 Form A is used in situations covered by the Japanese Electrical Appliance and Material Control Law, the use of 5.5 mm<sup>2</sup> cabling and 30 A current is not allowed. Consequently, the circuit should be less than 20 A.
4. When fixing the terminal socket with screws, to avoid torque damage and distortion, apply torque within the ranges shown below.  
M3.5 screws: 0.784 to 0.98 N·m (8 to 10 kgf·cm)  
M4 screws: 1.176 to 1.37 N·m (12 to 14 kgf·cm)

Please refer to **"the latest product specifications"** when designing your product.

• Requests to customers :

<https://industrial.panasonic.com/ac/e/salespolicies/>

# GUIDELINES FOR POWER RELAYS AND HIGH-CAPACITY DC CUT OFF RELAYS USAGE

For cautions for use, please read “GUIDELINES FOR RELAY USAGE”.

[https://industrial.panasonic.com/ac/e/control/relay/cautions\\_use/index.jsp](https://industrial.panasonic.com/ac/e/control/relay/cautions_use/index.jsp)

## Precautions for Coil Input

### ■ Long term current carrying

A circuit that will be carrying a current continuously for long periods without relay switching operation. (circuits for emergency lamps, alarm devices and error inspection that, for example, revert only during malfunction and output warnings with form B contacts) Continuous, long-term current to the coil will facilitate deterioration of coil insulation and characteristics due to heating of the coil itself.

For circuits such as these, please use a magnetic-hold type latching relay. If you need to use a single stable relay, use a sealed type relay that is not easily affected by ambient conditions and make a failsafe circuit design that considers the possibility of contact failure or disconnection.

### ■ DC Coil operating power

Steady state DC current should be applied to the coil. The wave form should be rectangular. If it includes ripple, the ripple factor should be less than 5%.

However, please check with the actual circuit since the electrical characteristics may vary. The rated coil voltage should be applied to the coil and the set/reset pulse time of latching type relay differs for each relays, please refer to the relay's individual specifications.

### ■ Coil connection

When connecting coils of polarized relays, please check coil polarity (+,-) at the internal connection diagram (Schematic). If any wrong connection is made, it may cause unexpected malfunction, like abnormal heat, fire and so on, and circuit do not work. Avoid impressing voltages to the set coil and reset coil at the same time.

## Ambient Environment

### ● Usage, Transport, and Storage Conditions

During usage, storage, or transportation, avoid locations subjected to direct sunlight and maintain normal temperature, humidity and pressure conditions.

### ● Temperature/Humidity/Pressure

When transporting or storing relays while they are tube packaged, there are cases the temperature may differ from the allowable range. In this case be sure to check the individual specifications. Also allowable humidity level is influenced by temperature, please check charts shown below and use relays within mentioned conditions. (Allowable temperature values differ for each relays, please refer to the relay's individual specifications.)

#### 1) Temperature:

The tolerance temperature range differs for each relays, please refer to the relay's individual specifications

#### 2) Humidity:

5 to 85 % RH

#### 3) Pressure:

86 to 106 kPa

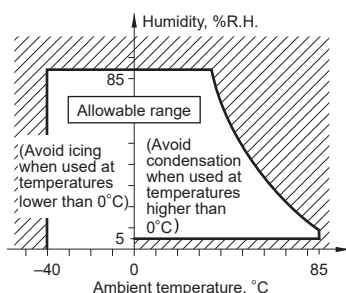

### ■ Maximum allowable voltage and temperature rise

Proper usage requires that the rated coil voltage be impressed on the coil. Note, however, that if a voltage greater than or equal to the maximum continuous voltage is impressed on the coil, the coil may burn or its layers short due to the temperature rise. Furthermore, do not exceed the usable ambient temperature range listed in the catalog.

### ■ Operate voltage change due to coil temperature rise (Hot start)

In DC relays, after continuous passage of current in the coil, if the current is turned OFF, then immediately turned ON again, due to the temperature rise in the coil, the pick-up voltage will become somewhat higher. Also, it will be the same as using it in a higher temperature atmosphere. The resistance/temperature relationship for copper wire is about 0.4% for 1°C, and with this ratio the coil resistance increases. That is, in order to operate of the relay, it is necessary that the voltage be higher than the pick-up voltage and the pick-up voltage rises in accordance with the increase in the resistance value. However, for some polarized relays, this rate of change is considerably smaller.

### ● Dew condensation

Condensation occurs when the ambient temperature drops suddenly from a high temperature and humidity, or the relay is suddenly transferred from a low ambient temperature to a high temperature and humidity. Condensation causes the failures like insulation deterioration, wire disconnection and rust etc. Panasonic Corporation does not guarantee the failures caused by condensation.

The heat conduction by the equipment may accelerate the cooling of device itself, and the condensation may occur. Please conduct product evaluations in the worst condition of the actual usage. (Special attention should be paid when high temperature heating parts are close to the device. Also please consider the condensation may occur inside of the device.)

### ● Icing

Condensation or other moisture may freeze on relays when the temperature become lower than 0°C. This icing causes the sticking of movable portion, the operation delay and the contact conduction failure etc. Panasonic Corporation does not guarantee the failures caused by the icing.

The heat conduction by the equipment may accelerate the cooling of relay itself and the icing may occur. Please conduct product evaluations in the worst condition of the actual usage.

### ● Low temperature and low humidity

The plastic becomes brittle if the switch is exposed to a low temperature, low humidity environment for long periods of time.

### ● High temperature and high humidity

Storage for extended periods of time (including transportation periods) at high temperature or high humidity levels or in atmospheres with organic gases or sulfide gases may cause a sulfide film or oxide film to form on the surfaces of the contacts and/or it may interfere with the functions. Check out the atmosphere in which the units are to be stored and transported.

## ●Package

In terms of the packing format used, make every effort to keep the effects of moisture, organic gases and sulfide gases to the absolute minimum.

## ●Silicon

When a source of silicone substances (silicone rubber, silicone oil, silicone coating materials and silicone filling materials etc.) is used around the relay, the silicone gas (low molecular siloxane etc.) may be produced.

This silicone gas may penetrate into the inside of the relay. When the relay is kept and used in this condition, silicone compound may adhere to the relay contacts which may cause the contact failure. Do not use any sources of silicone gas around the relay (Including plastic seal types).

## ●NOx Generation

When relay is used in an atmosphere high in humidity to switch a load which easily produces an arc, the NOx created by the arc and the water absorbed from outside the relay combine to produce nitric acid. This corrodes the internal metal parts and adversely affects operation. Avoid use at an ambient humidity of 85%RH or higher (at 20°C). If use at high humidity is unavoidable, please contact our sales representative.

## Others

### ■Cleaning

- 1) Although the environmentally sealed type relay (plastic sealed type, etc.) can be cleaned, avoid immersing the relay into cold liquid (such as cleaning solvent) immediately after soldering. Doing so may deteriorate the sealing performance.
- 2) Cleaning with the boiling method is recommended(The temperature of cleaning liquid should be 40°C or lower ).  
Avoid ultrasonic cleaning on relays. Use of ultrasonic cleaning may cause breaks in the coil or slight sticking of the contacts due to ultrasonic energy.

Please refer to **"the latest product specifications"** when designing your product.

•Requests to customers:

<https://industrial.panasonic.com/ac/e/salespolicies/>

---

Please contact .....

**Panasonic Corporation**

Electromechanical Control Business Division

■ 1006, Oaza Kadoma, Kadoma-shi, Osaka 571-8506, Japan  
[industrial.panasonic.com/ac/e/](http://industrial.panasonic.com/ac/e/)

**Panasonic**<sup>®</sup>

©Panasonic Corporation 2019