

- 1
- 2
- 3
- 4
- 5
- 6
- 7
- 8
- 9
- 10
- 11
- 12
- 13
- 14
- 15
- 16
- 17
- 18

LEVER BODY

Glass-fibre reinforced polyamide based (PA) technopolymer, grey-black colour, matte finish.

PUSH BUTTON

Technopolymer in Ergostyle colours, glossy finish.

STANDARD EXECUTIONS

Glass-fibre reinforced technopolymer clamping element with retaining pin, black colour, with knurling on the protruding part to make initial tightening easier. AISI 302 stainless steel return spring.

- **ERX-B:** brass boss, threaded blind hole.
- **ERX-SST:** AISI 303 stainless steel boss, threaded blind hole.
- **ERX-p:** zinc-plated steel threaded stud, chamfered flat end UNI 947 : ISO 4753 (see Technical data on page A-11).
- **ERX-SST-p:** AISI 303 stainless steel threaded stud, chamfered flat end UNI 947 : ISO 4753 (see Technical data on page A-11).

FEATURES AND APPLICATIONS

Particularly suitable when the lever turning angle is limited owing to lack of space.

Compared to other types of adjustable handles with metal retaining screw this solution offers:

- absolute electric insulation for the operator
- no visible steel parts subject to rust
- more comfortable lever release.

STRESS RESISTANCE

Adjustable handles are generally used for repetitive clamping operations sometimes with very high-frequency.

Therefore, the stress resistance (i.e. the resistance to repeated tightening cycles) of the handle unit is particularly important and, especially, the strength of the toothed element which transmits the tightening force from the handle to the threaded element (boss or stud).

In fact, the results of several laboratory tests, performed with a special instrument that simulates the most severe use conditions, have shown that e.g. ERX.78 adjustable handle can withstand without yielding more than 100,000 tightening cycles, under the action of a force of 490 N (see graphic).

The special glass-fibre reinforced technopolymer enables the ELESAs adjustable handles to guarantee stress resistance values which are much higher than the ones generated under normal working conditions.

OTHER EXECUTIONS AVAILABLE

Lever body in orange (C2) with black push button (C1).

Example: code 233061-C2-C1 description ERX.30-C2-B-M3-C1.

INSTRUCTIONS OF USE

For clamping, lift the lever to disengage the clamping device teeth and bring it back to start position. By releasing the lever, the return spring automatically engages the teeth.

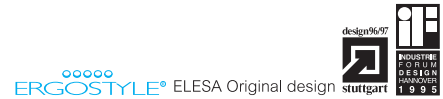

NUMBER OF TIGHTENINGS

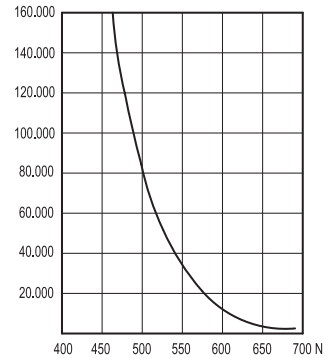

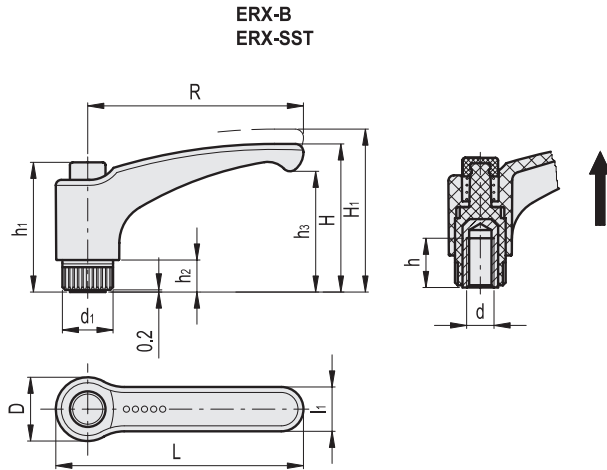

*Complete with colour index, example: 233061-C2 ERX.30 B-M3-C2

C1 C2 C3 C4 C5 C6 C17
 RAL7021 RAL2004 RAL7035 RAL1021 RAL5024 RAL3000 RAL6017

ERX-B

Code	Description	R	d6H	L	D	H	H1	h	h1	h2	h3	d1	l1	Teeth no.	⚖️
233061-*	ERX.30 B-M3-*	30	M3	37.5	15	30	33.5	6	29.5	6	23	12	9	18	8
233066-*	ERX.30 B-M4-*	30	M4	37.5	15	30	33.5	10	29.5	6	23	12	9	18	8
233071-*	ERX.30 B-M5-*	30	M5	37.5	15	30	33.5	10	29.5	6	23	12	9	18	7
233076-*	ERX.30 B-M6-*	30	M6	37.5	15	30	33.5	10	29.5	6	23	12	9	18	6
233101-*	ERX.44 B-M5-*	44	M5	52	16	32.5	36	10	29.5	6	25	12	11	18	10
233106-*	ERX.44 B-M6-*	44	M6	52	16	32.5	36	10	29.5	6	25	12	11	18	10
233131-*	ERX.63 B-M6-*	63	M6	72.5	19	43	47	16	37.5	8	34.5	15	13.5	20	21
233136-*	ERX.63 B-M8-*	63	M8	72.5	19	43	47	13	37.5	8	34.5	15	13.5	20	20
233141-*	ERX.63 B-M10-*	63	M10	72.5	19	43	47	13	37.5	8	34.5	15	13.5	20	19
233151-*	ERX.78 B-M8-*	78	M8	89.5	23	54	58	20	47	12	44	19	16	24	46
233156-*	ERX.78 B-M10-*	78	M10	89.5	23	54	58	18	47	12	44	19	16	24	44
233161-*	ERX.78 B-M12-*	78	M12	89.5	23	54	58	17	47	12	44	19	16	24	43
233171-*	ERX.95 B-M10-*	95	M10	108	26	64.5	69	20	54.5	13	53	21.5	18	26	52
233176-*	ERX.95 B-M12-*	95	M12	108	26	64.5	69	20	54.5	13	53	21.5	18	26	51
233181-*	ERX.95 B-M14-*	95	M14	108	26	64.5	69	20	54.5	13	53	21.5	18	26	50
233211-*	ERX.108 B-M12-*	108	M12	123	30	65.5	70	20	54.5	11	52.5	25	20	28	60
233216-*	ERX.108 B-M14-*	108	M14	123	30	65.5	70	20	54.5	11	52.5	25	20	28	59
233221-*	ERX.108 B-M16-*	108	M16	123	30	65.5	70	22	54.5	11	52.5	25	20	28	58

ERX-SST



Code	Description	R	d6H	L	D	H	H1	h	h1	h2	h3	d1	l1	Teeth no.	⚖️
235069-*	ERX.30 SST-M3-*	30	M3	37.5	15	30	33.5	6	29.5	6	23	12	9	18	8
235070-*	ERX.30 SST-M4-*	30	M4	37.5	15	30	33.5	10	29.5	6	23	12	9	18	8
235071-*	ERX.30 SST-M5-*	30	M5	37.5	15	30	33.5	6	29.5	6	23	12	9	18	8
235076-*	ERX.30 SST-M6-*	30	M6	37.5	15	30	33.5	10	29.5	6	23	12	9	18	6
235101-*	ERX.44 SST-M5-*	44	M5	52	16	32.5	36	6	29.5	6	25	12	11	18	11
235106-*	ERX.44 SST-M6-*	44	M6	52	16	32.5	36	10	29.5	6	25	12	11	18	10
235131-*	ERX.63 SST-M6-*	63	M6	72.5	19	43	47	12	37.5	8	34.5	15	13.5	20	22
235136-*	ERX.63 SST-M8-*	63	M8	72.5	19	43	47	13	37.5	8	34.5	15	13.5	20	20
235151-*	ERX.78 SST-M8-*	78	M8	89.5	23	54	58	13	47	12	44	19	16	24	46
235156-*	ERX.78 SST-M10-*	78	M10	89.5	23	54	58	17	47	12	44	19	16	24	44
235176-*	ERX.95 SST-M12-*	95	M12	108	26	64.5	69	20	54.5	13	53	21.5	18	26	52
235191-*	ERX.108 SST-M12-*	108	M12	123	30	65.5	70	20	54.5	11	52.5	25	20	28	60



Clamping handles

- 1
- 2
- 3
- 4
- 5
- 6
- 7
- 8
- 9
- 10
- 11
- 12
- 13
- 14
- 15
- 16
- 17
- 18

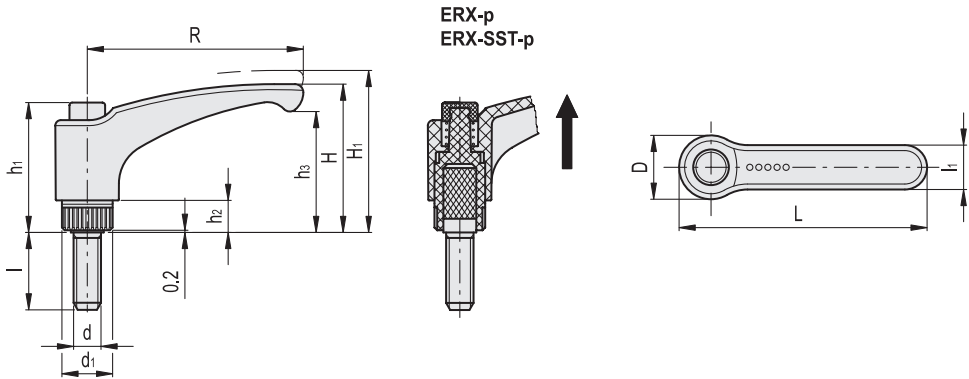

ERX-p
ERX-SST-p



* Complete with colour index, example: 234001-C2 ERX.30 p-M5x10-C2

- C1 RAL7021
- C2 RAL2004
- C3 RAL7035
- C4 RAL1021
- C5 RAL5024
- C6 RAL3000
- C17 RAL6017

ERX-p

Code	Description	R	d6g	L	D	H	H1	h1	h2	h3	d1	l	l1	Teeth no.	
234001.*	ERX.30 p-M5x10.*	30	M5	37.5	15	30	33.5	29.5	6	23	12	10	9	18	6
234006.*	ERX.30 p-M5x16.*	30	M5	37.5	15	30	33.5	29.5	6	23	12	16	9	18	6
234011.*	ERX.30 p-M5x20.*	30	M5	37.5	15	30	33.5	29.5	6	23	12	20	9	18	7
234016.*	ERX.30 p-M6x10.*	30	M6	37.5	15	30	33.5	29.5	6	23	12	10	9	18	8
234021.*	ERX.30 p-M6x16.*	30	M6	37.5	15	30	33.5	29.5	6	23	12	16	9	18	9
234026.*	ERX.30 p-M6x20.*	30	M6	37.5	15	30	33.5	29.5	6	23	12	20	9	18	10
234031.*	ERX.30 p-M6x25.*	30	M6	37.5	15	30	33.5	29.5	6	23	12	25	9	18	11
234036.*	ERX.30 p-M6x30.*	30	M6	37.5	15	30	33.5	29.5	6	23	12	30	9	18	12
234046.*	ERX.30 p-M6x40.*	30	M6	37.5	15	30	33.5	29.5	6	23	12	40	9	18	14
234101.*	ERX.44 p-M5x10.*	44	M5	52	16	32.5	36	29.5	6	25	12	10	11	18	11
234106.*	ERX.44 p-M5x16.*	44	M5	52	16	32.5	36	29.5	6	25	12	16	11	18	12
234111.*	ERX.44 p-M5x20.*	44	M5	52	16	32.5	36	29.5	6	25	12	20	11	18	13
234116.*	ERX.44 p-M6x10.*	44	M6	52	16	32.5	36	29.5	6	25	12	10	11	18	13
234121.*	ERX.44 p-M6x16.*	44	M6	52	16	32.5	36	29.5	6	25	12	16	11	18	14
234126.*	ERX.44 p-M6x20.*	44	M6	52	16	32.5	36	29.5	6	25	12	20	11	18	15
234131.*	ERX.44 p-M6x25.*	44	M6	52	16	32.5	36	29.5	6	25	12	25	11	18	16
234136.*	ERX.44 p-M6x30.*	44	M6	52	16	32.5	36	29.5	6	25	12	30	11	18	17
234146.*	ERX.44 p-M6x40.*	44	M6	52	16	32.5	36	29.5	6	25	12	40	11	18	19
234151.*	ERX.44 p-M6x45.*	44	M6	52	16	32.5	36	29.5	6	25	12	45	11	18	20
234159.*	ERX.44 p-M8x16.*	44	M8	52	16	32.5	36	29.5	6	25	12	16	11	18	17
234161.*	ERX.44 p-M8x20.*	44	M8	52	16	32.5	36	29.5	6	25	12	20	11	18	18
234163.*	ERX.44 p-M8x25.*	44	M8	52	16	32.5	36	29.5	6	25	12	25	11	18	19
234301.*	ERX.63 p-M6x10.*	63	M6	72.5	19	43	47	37.5	8	34.5	15	10	13.5	20	28
234306.*	ERX.63 p-M6x16.*	63	M6	72.5	19	43	47	37.5	8	34.5	15	16	13.5	20	29
234311.*	ERX.63 p-M6x20.*	63	M6	72.5	19	43	47	37.5	8	34.5	15	20	13.5	20	30
234316.*	ERX.63 p-M6x25.*	63	M6	72.5	19	43	47	37.5	8	34.5	15	25	13.5	20	31
234321.*	ERX.63 p-M6x30.*	63	M6	72.5	19	43	47	37.5	8	34.5	15	30	13.5	20	32
234323.*	ERX.63 p-M6x35.*	63	M6	72.5	19	43	47	37.5	8	34.5	15	35	13.5	20	32
234326.*	ERX.63 p-M6x40.*	63	M6	72.5	19	43	47	37.5	8	34.5	15	40	13.5	20	32
234329.*	ERX.63 p-M6x50.*	63	M6	72.5	19	43	47	37.5	8	34.5	15	50	13.5	20	32
234333.*	ERX.63 p-M8x16.*	63	M8	72.5	19	43	47	37.5	8	34.5	15	16	13.5	20	32
234336.*	ERX.63 p-M8x20.*	63	M8	72.5	19	43	47	37.5	8	34.5	15	20	13.5	20	32
234341.*	ERX.63 p-M8x25.*	63	M8	72.5	19	43	47	37.5	8	34.5	15	25	13.5	20	34
234346.*	ERX.63 p-M8x30.*	63	M8	72.5	19	43	47	37.5	8	34.5	15	30	13.5	20	36
234351.*	ERX.63 p-M8x35.*	63	M8	72.5	19	43	47	37.5	8	34.5	15	35	13.5	20	38
234356.*	ERX.63 p-M8x40.*	63	M8	72.5	19	43	47	37.5	8	34.5	15	40	13.5	20	40
234361.*	ERX.63 p-M8x45.*	63	M8	72.5	19	43	47	37.5	8	34.5	15	45	13.5	20	41
234366.*	ERX.63 p-M8x50.*	63	M8	72.5	19	43	47	37.5	8	34.5	15	50	13.5	20	43
234371.*	ERX.63 p-M8x60.*	63	M8	72.5	19	43	47	37.5	8	34.5	15	60	13.5	20	46
234376.*	ERX.63 p-M8x70.*	63	M8	72.5	19	43	47	37.5	8	34.5	15	70	13.5	20	50
234378.*	ERX.63 p-M8x80.*	63	M8	72.5	19	43	47	37.5	8	34.5	15	80	13.5	20	50
234381.*	ERX.63 p-M10x20.*	63	M10	72.5	19	43	47	37.5	8	34.5	15	20	13.5	20	40
234382.*	ERX.63 p-M10x30.*	63	M10	72.5	19	43	47	37.5	8	34.5	15	30	13.5	20	43
234383.*	ERX.63 p-M10x40.*	63	M10	72.5	19	43	47	37.5	8	34.5	15	40	13.5	20	46
234385.*	ERX.63 p-M10x50.*	63	M10	72.5	19	43	47	37.5	8	34.5	15	50	13.5	20	50
234387.*	ERX.63 p-M10x60.*	63	M10	72.5	19	43	47	37.5	8	34.5	15	60	13.5	20	54

Clamping handles



*Complete with colour index, example: 234498-C2 ERX.78 p-M8x20-C2

C1 RAL7021
 C2 RAL2004
 C3 RAL7035
 C4 RAL1021
 C5 RAL5024
 C6 RAL3000
 C17 RAL6017

ERX-p

Code	Description	R	d6g	L	D	H	H1	h1	h2	h3	d1	l	l1	Teeth no.	
234498-*	ERX.78 p-M8x20-*	78	M8	89.5	23	54	58	47	12	44	19	20	16	24	42
234501-*	ERX.78 p-M8x25-*	78	M8	89.5	23	54	58	47	12	44	19	25	16	24	43
234503-*	ERX.78 p-M8x30-*	78	M8	89.5	23	54	58	47	12	44	19	30	16	24	44
234506-*	ERX.78 p-M8x40-*	78	M8	89.5	23	54	58	47	12	44	19	40	16	24	48
234507-*	ERX.78 p-M8x45-*	78	M8	89.5	23	54	58	47	12	44	19	45	16	24	50
234509-*	ERX.78 p-M8x50-*	78	M8	89.5	23	54	58	47	12	44	19	50	16	24	52
234511-*	ERX.78 p-M8x55-*	78	M8	89.5	23	54	58	47	12	44	19	55	16	24	55
234513-*	ERX.78 p-M8x60-*	78	M8	89.5	23	54	58	47	12	44	19	60	16	24	57
234515-*	ERX.78 p-M8x70-*	78	M8	89.5	23	54	58	47	12	44	19	70	16	24	60
234516-*	ERX.78 p-M10x20-*	78	M10	89.5	23	54	58	47	12	44	19	20	16	24	58
234521-*	ERX.78 p-M10x25-*	78	M10	89.5	23	54	58	47	12	44	19	25	16	24	61
234526-*	ERX.78 p-M10x30-*	78	M10	89.5	23	54	58	47	12	44	19	30	16	24	64
234531-*	ERX.78 p-M10x35-*	78	M10	89.5	23	54	58	47	12	44	19	35	16	24	67
234536-*	ERX.78 p-M10x40-*	78	M10	89.5	23	54	58	47	12	44	19	40	16	24	70
234541-*	ERX.78 p-M10x50-*	78	M10	89.5	23	54	58	47	12	44	19	50	16	24	76
234546-*	ERX.78 p-M10x60-*	78	M10	89.5	23	54	58	47	12	44	19	60	16	24	82
234551-*	ERX.78 p-M10x70-*	78	M10	89.5	23	54	58	47	12	44	19	70	16	24	88
234561-*	ERX.78 p-M12x20-*	78	M12	89.5	23	54	58	47	12	44	19	20	16	24	70
234566-*	ERX.78 p-M12x25-*	78	M12	89.5	23	54	58	47	12	44	19	25	16	24	71
234571-*	ERX.78 p-M12x30-*	78	M12	89.5	23	54	58	47	12	44	19	30	16	24	74
234573-*	ERX.78 p-M12x35-*	78	M12	89.5	23	54	58	47	12	44	19	35	16	24	75
234576-*	ERX.78 p-M12x40-*	78	M12	89.5	23	54	58	47	12	44	19	40	16	24	76
234581-*	ERX.78 p-M12x45-*	78	M12	89.5	23	54	58	47	12	44	19	45	16	24	77
234586-*	ERX.78 p-M12x50-*	78	M12	89.5	23	54	58	47	12	44	19	50	16	24	78
234591-*	ERX.78 p-M12x60-*	78	M12	89.5	23	54	58	47	12	44	19	60	16	24	81
234593-*	ERX.78 p-M12x70-*	78	M12	89.5	23	54	58	47	12	44	19	70	16	24	84
234596-*	ERX.78 p-M12x80-*	78	M12	89.5	23	54	58	47	12	44	19	80	16	24	86
234716-*	ERX.95 p-M12x20-*	95	M12	108	26	64.5	69	54.5	13	53	21.5	20	18	26	86
234726-*	ERX.95 p-M12x30-*	95	M12	108	26	64.5	69	54.5	13	53	21.5	30	18	26	86
234741-*	ERX.95 p-M12x50-*	95	M12	108	26	64.5	69	54.5	13	53	21.5	50	18	26	90
234751-*	ERX.95 p-M12x70-*	95	M12	108	26	64.5	69	54.5	13	53	21.5	70	18	26	94
234901-*	ERX.95 p-M16x30-*	95	M16	108	26	64.5	69	54.5	13	53	21.5	30	18	26	104
234911-*	ERX.95 p-M16x50-*	95	M16	108	26	64.5	69	54.5	13	53	21.5	50	18	26	110
234921-*	ERX.95 p-M16x70-*	95	M16	108	26	64.5	69	54.5	13	53	21.5	70	18	26	116
234996-*	ERX.108 p-M12x20-*	108	M12	123	30	65.5	70	54.5	11	52.5	25	20	20	28	70
235001-*	ERX.108 p-M12x30-*	108	M12	123	30	65.5	70	54.5	11	52.5	25	30	20	28	70
235006-*	ERX.108 p-M12x50-*	108	M12	123	30	65.5	70	54.5	11	52.5	25	50	20	28	75
235011-*	ERX.108 p-M12x70-*	108	M12	123	30	65.5	70	54.5	11	52.5	25	70	20	28	80
235016-*	ERX.108 p-M14x30-*	108	M14	123	30	65.5	70	54.5	11	52.5	25	30	20	28	86
235021-*	ERX.108 p-M14x50-*	108	M14	123	30	65.5	70	54.5	11	52.5	25	50	20	28	90
235026-*	ERX.108 p-M14x70-*	108	M14	123	30	65.5	70	54.5	11	52.5	25	70	20	28	95
235036-*	ERX.108 p-M16x30-*	108	M16	123	30	65.5	70	54.5	11	52.5	25	30	20	28	100
235041-*	ERX.108 p-M16x50-*	108	M16	123	30	65.5	70	54.5	11	52.5	25	50	20	28	105
235046-*	ERX.108 p-M16x70-*	108	M16	123	30	65.5	70	54.5	11	52.5	25	70	20	28	110

ERX-SST-p



Code	Description	R	d6g	L	D	H	H1	h1	h2	h3	d1	l	l1	Teeth no.	
235061-*	ERX.30-SST-p M5x10-*	30	M5	37.5	15	30	33.5	29.5	6	23	12	10	9	18	6
235066-*	ERX.30-SST-p M5x16-*	30	M5	37.5	15	30	33.5	29.5	6	23	12	16	9	18	7
235196-*	ERX.30-SST-p M6x10-*	30	M6	37.5	15	30	33.5	29.5	6	23	12	10	9	18	8
235201-*	ERX.30-SST-p M6x16-*	30	M6	37.5	15	30	33.5	29.5	6	23	12	16	9	18	9
235203-*	ERX.30-SST-p M6x20-*	30	M6	37.5	15	30	33.5	29.5	6	23	12	20	9	18	10
235205-*	ERX.30-SST-p M6x25-*	30	M6	37.5	15	30	33.5	29.5	6	23	12	25	9	18	11
235207-*	ERX.30-SST-p M6x30-*	30	M6	37.5	15	30	33.5	29.5	6	23	12	30	9	18	12
235209-*	ERX.44-SST-p M5x10-*	44	M5	52	16	32.5	36	29.5	6	25	12	10	11	18	10
235211-*	ERX.44-SST-p M5x16-*	44	M5	52	16	32.5	36	29.5	6	25	12	16	11	18	12
235216-*	ERX.44-SST-p M6x10-*	44	M6	52	16	32.5	36	29.5	6	25	12	10	11	18	13
235221-*	ERX.44-SST-p M6x16-*	44	M6	52	16	32.5	36	29.5	6	25	12	16	11	18	14
235226-*	ERX.44-SST-p M6x20-*	44	M6	52	16	32.5	36	29.5	6	25	12	20	11	18	16
235231-*	ERX.44-SST-p M6x25-*	44	M6	52	16	32.5	36	29.5	6	25	12	25	11	18	17
235236-*	ERX.44-SST-p M6x30-*	44	M6	52	16	32.5	36	29.5	6	25	12	30	11	18	18

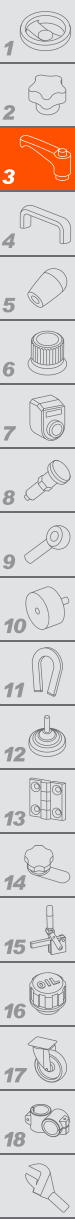

Clamping handles

- 1
- 2
- 3
- 4
- 5
- 6
- 7
- 8
- 9
- 10
- 11
- 12
- 13
- 14
- 15
- 16
- 17
- 18
- Clamping handles
- 6

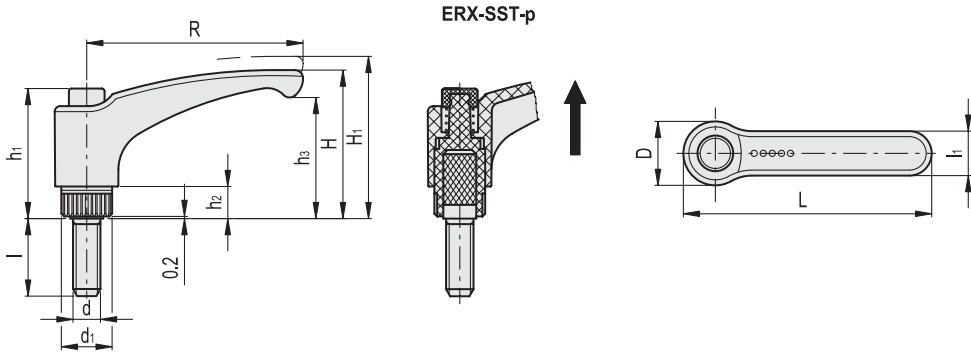

* Complete with colour index, example: 235341-C2 ERX.63 SST-p-M6x10-C2

- C1
RAL7021
- C2
RAL2004
- C3
RAL7035
- C4
RAL1021
- C5
RAL5024
- C6
RAL3000
- C7
RAL6017



ERX-SST-p

Code	Description	R	d6g	L	D	H	H1	h1	h2	h3	d1	l	l1	Teeth no.	△
235341-*	ERX.63 SST-p-M6x10-*	63	M6	72.5	19	43	47	37.5	8	34.5	15	10	13.5	20	30
235351-*	ERX.63 SST-p-M6x20-*	63	M6	72.5	19	43	47	37.5	8	34.5	15	20	13.5	20	31
235421-*	ERX.63 SST-p-M6x30-*	63	M6	72.5	19	43	47	37.5	8	34.5	15	30	13.5	20	32
235426-*	ERX.63 SST-p-M6x40-*	63	M6	72.5	19	43	47	37.5	8	34.5	15	40	13.5	20	33
235431-*	ERX.63 SST-p-M8x16-*	63	M8	72.5	19	43	47	37.5	8	34.5	15	16	13.5	20	31
235436-*	ERX.63 SST-p-M8x20-*	63	M8	72.5	19	43	47	37.5	8	34.5	15	20	13.5	20	32
235441-*	ERX.63 SST-p-M8x25-*	63	M8	72.5	19	43	47	37.5	8	34.5	15	25	13.5	20	33
235446-*	ERX.63 SST-p-M8x30-*	63	M8	72.5	19	43	47	37.5	8	34.5	15	30	13.5	20	37
235451-*	ERX.63 SST-p-M8x35-*	63	M8	72.5	19	43	47	37.5	8	34.5	15	35	13.5	20	38
235456-*	ERX.63 SST-p-M8x40-*	63	M8	72.5	19	43	47	37.5	8	34.5	15	40	13.5	20	41
235461-*	ERX.63 SST-p-M8x45-*	63	M8	72.5	19	43	47	37.5	8	34.5	15	45	13.5	20	42
235466-*	ERX.63 SST-p-M8x50-*	63	M8	72.5	19	43	47	37.5	8	34.5	15	50	13.5	20	44
235471-*	ERX.63 SST-p-M8x60-*	63	M8	72.5	19	43	47	37.5	8	34.5	15	60	13.5	20	47
235476-*	ERX.63 SST-p-M8x70-*	63	M8	72.5	19	43	47	37.5	8	34.5	15	70	13.5	20	52
235601-*	ERX.78 SST-p-M8x20-*	78	M8	89.5	23	54	58	47	12	44	19	20	16	24	43
235603-*	ERX.78 SST-p-M8x25-*	78	M8	89.5	23	54	58	47	12	44	19	25	16	24	44
235605-*	ERX.78 SST-p-M8x30-*	78	M8	89.5	23	54	58	47	12	44	19	30	16	24	45
235607-*	ERX.78 SST-p-M8x40-*	78	M8	89.5	23	54	58	47	12	44	19	40	16	24	50
235609-*	ERX.78 SST-p-M8x45-*	78	M8	89.5	23	54	58	47	12	44	19	45	16	24	52
235611-*	ERX.78 SST-p-M8x50-*	78	M8	89.5	23	54	58	47	12	44	19	50	16	24	54
235617-*	ERX.78 SST-p-M8x70-*	78	M8	89.5	23	54	58	47	12	44	19	70	16	24	62
235618-*	ERX.78 SST-p-M8x80-*	78	M8	89.5	23	54	58	47	12	44	19	80	16	24	64
235716-*	ERX.78 SST-p-M10x20-*	78	M10	89.5	23	54	58	47	12	44	19	20	16	24	58
235726-*	ERX.78 SST-p-M10x30-*	78	M10	89.5	23	54	58	47	12	44	19	30	16	24	64
235731-*	ERX.78 SST-p-M10x35-*	78	M10	89.5	23	54	58	47	12	44	19	35	16	24	66
235736-*	ERX.78 SST-p-M10x40-*	78	M10	89.5	23	54	58	47	12	44	19	40	16	24	67
235741-*	ERX.78 SST-p-M10x50-*	78	M10	89.5	23	54	58	47	12	44	19	50	16	24	68
235746-*	ERX.78 SST-p-M10x60-*	78	M10	89.5	23	54	58	47	12	44	19	60	16	24	70
235771-*	ERX.78 SST-p-M12x30-*	78	M12	89.5	23	54	58	47	12	44	19	30	16	24	74
235773-*	ERX.78 SST-p-M12x35-*	78	M12	89.5	23	54	58	47	12	44	19	35	16	24	76
235781-*	ERX.78 SST-p-M12x40-*	78	M12	89.5	23	54	58	47	12	44	19	40	16	24	77
235786-*	ERX.78 SST-p-M12x50-*	78	M12	89.5	23	54	58	47	12	44	19	50	16	24	79
235893-*	ERX.78 SST-p-M12x70-*	78	M12	89.5	23	54	58	47	12	44	19	70	16	24	82
235901-*	ERX.95 SST-p-M12x30-*	95	M12	108	26	64.5	69	54.5	13	53	21.5	30	18	26	87
235911-*	ERX.95 SST-p-M12x40-*	95	M12	108	26	64.5	69	54.5	13	53	21.5	40	18	26	90
235921-*	ERX.95 SST-p-M12x50-*	95	M12	108	26	64.5	69	54.5	13	53	21.5	50	18	26	93
235941-*	ERX.95 SST-p-M12x70-*	95	M12	108	26	64.5	69	54.5	13	53	21.5	70	18	26	98
236001-*	ERX.108 SST-p-M12x30-*	108	M12	123	30	65.5	70	54.5	11	52.5	25	30	20	28	70
236003-*	ERX.108 SST-p-M12x40-*	108	M12	123	30	65.5	70	54.5	11	52.5	25	40	20	28	73
236006-*	ERX.108 SST-p-M12x50-*	108	M12	123	30	65.5	70	54.5	11	52.5	25	50	20	28	75
236011-*	ERX.108 SST-p-M12x70-*	108	M12	123	30	65.5	70	54.5	11	52.5	25	70	20	28	80