

- 1
- 2
- 3
- 4
- 5
- 6
- 7
- 8
- 9
- 10
- 11
- 12
- 13
- 14
- 15
- 16
- 17
- 18

**BODY**

Transparent polyamide based (PA-T) technopolymer. Highly resistant to shocks, solvents, oils with additives, aliphatic and aromatic hydrocarbons, petrol, naphtha, phosphoric esters.  
Avoid contact with alcohol or detergents containing alcohol.

**PACKING RINGS**

- NBR: synthetic rubber O-Ring.
- FKM: FKM type VITON®-O-Ring.

Suggested roughness of the packing ring application surface Ra = 3 µm.  
\* Registered trademark by DuPont Dow Elastomers.

**CONTRAST SCREEN**

White lacquered aluminium. The housing, in the appropriate external rear slot, guarantees the best protection from direct contact with fluid. It can be taken out from the inclined side, before assembly to allow the insertion of level lines or words.

**STANDARD EXECUTIONS**

- **HCX.**: zinc-plated steel screws, nuts and washers, NBR packing ring.
- **HCX-SST**: AISI 303 stainless steel screws, AISI 304 stainless steel nuts and washers, FKM packing ring.
- **HCX-VT**: glass-fibre reinforced polyamide based (PA) SUPER-technopolymer screws, AISI 304 stainless steel nuts and washers, NBR packing ring.

**MAXIMUM CONTINUOUS WORKING TEMPERATURE**

90°C (with oil).

**FEATURES AND PERFORMANCES**

Ultrasound welding to guarantee a perfect seal.  
Maximum fluid level visibility even from side positions.  
Lens effect for a better visibility of the fluid level.  
Thanks to the SUPER-technopolymer screws, HCX/VT column level indicator can be used in corrosion resistance applications where stainless steel is not necessary.  
The special slotted head of the SUPER-technopolymer screws is especially designed to reach an optimum tightening of the packing rings by applying an adequate tightening torque (ELESA patent) thus avoiding unnecessary stress to the screws.

**TECHNICAL DATA**

In laboratory tests carried out with mineral oil type CB68 (according to ISO 3498) at 23°C for a limited period of time, the weld stood up to: 18 bar (HCX.76 e HCX.127) 12 bar (HCX.254).  
Considering the SUPER-technopolymer screws, the maximum working pressure cannot be higher than 5 bar at 20°C and 2 bar at 90°C.  
For use with other fluids and under different pressure and temperature conditions, please contact ELESA Technical Department.  
In any case we suggest to verify the suitability of the product under the actual working conditions.

**SPECIAL EXECUTIONS ON REQUEST**

- Indicators with two red ball-shaped floats.
- Indicators with cylindrical or step-shaped (NBR or FKM) packing rings (instead of OR) for mounting on reservoirs having rough surfaces or in any case not perfectly flat.

**ACCESSORIES ON REQUEST**

When fitting is not possible from the inside of the reservoir and the walls are not thick enough, the screws can be used together with Fast Mounting Kit (see page 1221)



ELESA Original design

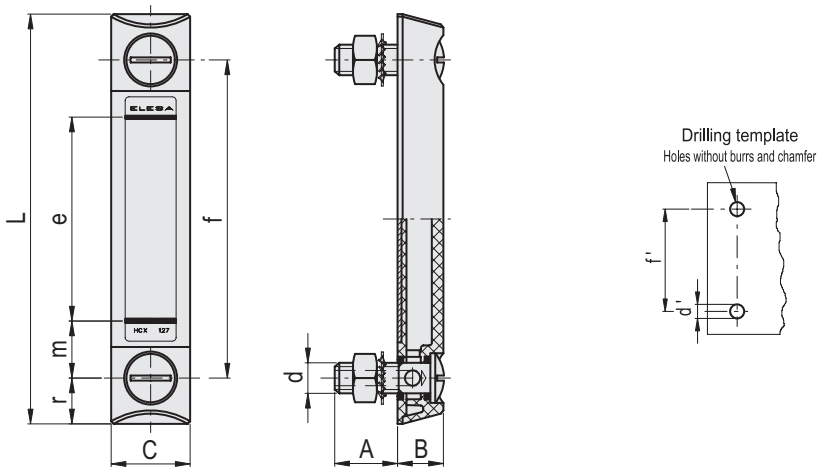

HCX.

Code	Description	f	d	A	B	C	L	e	m	r	d <sup>±0.2</sup>	f <sup>±0.2</sup>	C# [Nm]	⚖
11341	HCX.76-M10	76	M10	22	16	27	107	40	18	15.5	10.5	76	12	87
11349	HCX.127-M10	127	M10	23	18	31	161	80	23	17	10.5	127	12	138
11351	HCX.127-M12	127	M12	23	18	31	161	80	23	17	12.5	127	12	138
11361	HCX.254-M12	254	M12	21	18	35	291	203	26	18.5	12.5	254	10	185

HCX-SST



Code	Description	f	d	A	B	C	L	e	m	r	d <sup>±0.2</sup>	f <sup>±0.2</sup>	C# [Nm]	⚖
11343	HCX.76-SST-M10	76	M10	22	16	27	107	40	18	15.5	10.5	76	12	87
11353	HCX.127-SST-M12	127	M12	23	18	31	161	80	23	17	12.5	127	12	138
11363	HCX.254-SST-M12	254	M12	21	18	35	291	203	26	18.5	12.5	254	10	185

HCX-VT

Code	Description	f	d	A	B	C	L	e	m	r	d <sup>±0.2</sup>	f <sup>±0.2</sup>	C# [Nm]	⚖
111351	HCX.127-VT-M12	127	M12	23	18	31	161	80	23	17	12.5	127	6	94
111371	HCX.254-VT-M12	254	M12	21	18	35	291	203	26	18.5	12.5	254	6	141

# Maximum tightening torque.

