

P	LTR	DESCRIPTION	DATE	DWN	APVD
	N	DRAWING REDRAWN. PLASTIC SUPPLIER CHANGED	27MAY2021	SB	KJK

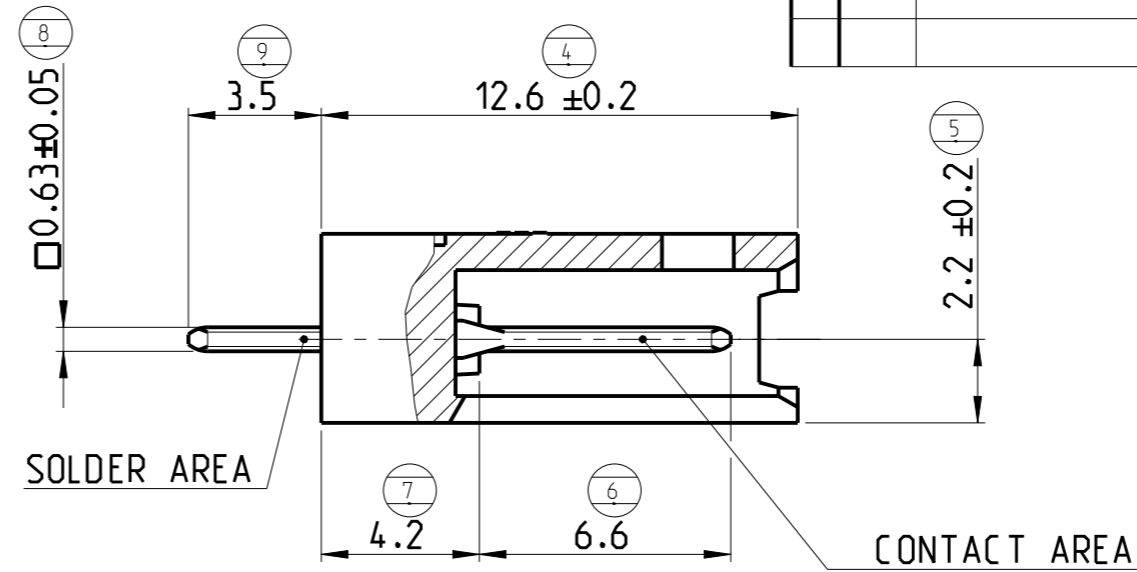

PARTIAL SEC Z-Z

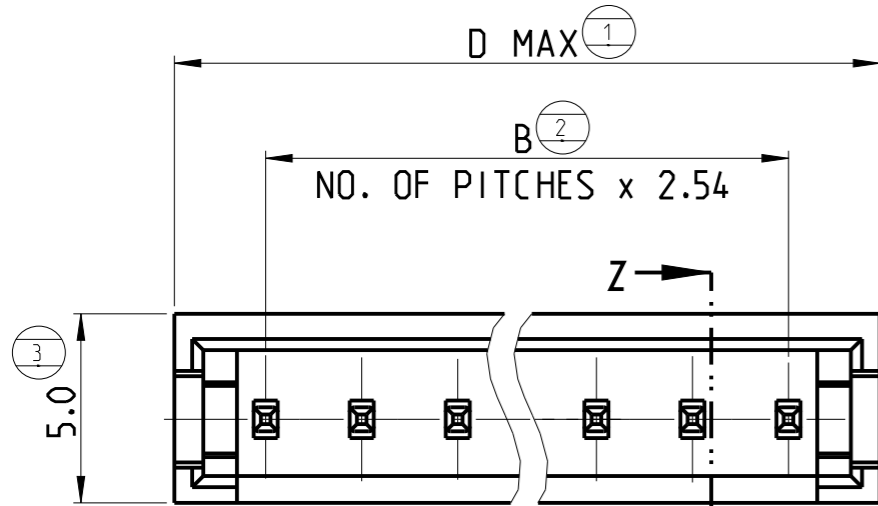
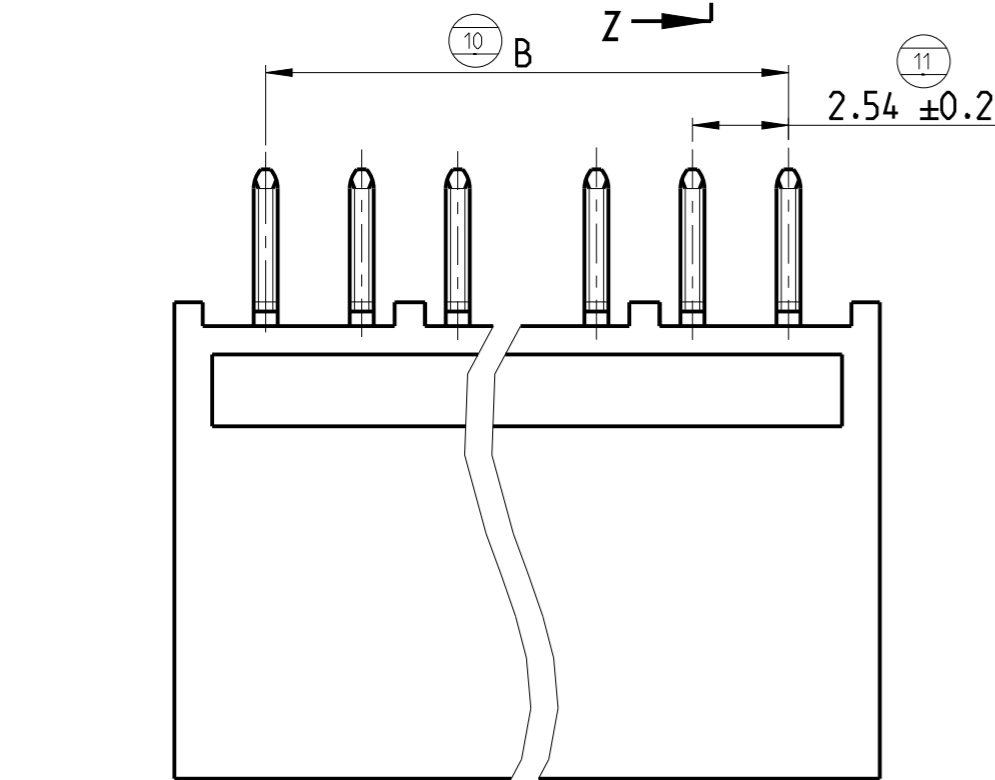

58.5	53.34	280376-3	<del>280376-2</del> 5	280376-1	22
40.7	35.56	280375-3	280375-2	280375-1	15
33.1	27.94	280520-3	280520-2	280520-1	12
28.0	22.86	280374-3	280374-2	280374-1	10
25.4	20.32	<del>280508-3</del> 6	280508-2	280508-1	9
22.9	17.78	<del>280373-3</del> 5	280373-2	280373-1	8
17.8	12.70	280372-3	280372-2	280372-1	6
12.7	7.62	280371-3	280371-2	280371-1	4
7.7	2.54	280370-3	280370-2	280370-1	2
D	B	PART NUMBER 3	PART NUMBER 2	PART NUMBER 1	NO. OF POS.

NOTES:

- 1 FINISH: 3-5  $\mu$ m TIN OVER MIN 1.27  $\mu$ m NICKEL
- 2 FINISH: DUPLEX PLATED MIN 0.38  $\mu$ m GOLD IN CONTACT AREA AND 2.5  $\mu$ m TIN IN SOLDER AREA. OVER MIN 1.27  $\mu$ m NICKEL.
- 3 FINISH: DUPLEX PLATED MIN 0.76  $\mu$ m GOLD IN CONTACT AREA AND 2.5  $\mu$ m TIN IN SOLDER AREA. OVER MIN 1.27  $\mu$ m NICKEL.
- 4 MATERIALS:  
-HOUSINGS: FLAME RETARDANT THERMOPLASTIC. UL94V0. COLOR BLACK.  
-TIN AND GOLD PLATED CONTACT: BRASS
- 5 OBSOLETE PN
- 6 PN SUPERSEDED BY 280508-2

THIS DRAWING IS A CONTROLLED DOCUMENT.		DWN G. CAMPIA 12FEB1990		
DIMENSIONS: mm		CHK -		
TOLERANCES UNLESS OTHERWISE SPECIFIED: ±0.3		APVD -	NAME AMPMODU II SHROUDED HEADER SINGLE ROW, STRAIGHT POST	
		PRODUCT SPEC 108-20025	SIZE A3	
MATERIAL 4		APPLICATION SPEC -	CAGE CODE 00779	DRAWING NO C-280370
FINISH -		WEIGHT -	RESTRICTED TO -	SCALE 5:1
		CUSTOMER DRAWING	SHEET 1 OF 1	REV N