

REV.	DESCRIPTION	DRAWN	CHECKED	APPROVED
A	NEW RELEASE	YCH 07/07/07	~	LJC 07/07/07
B	整理图面	YCH 05/21/08	~	

Male

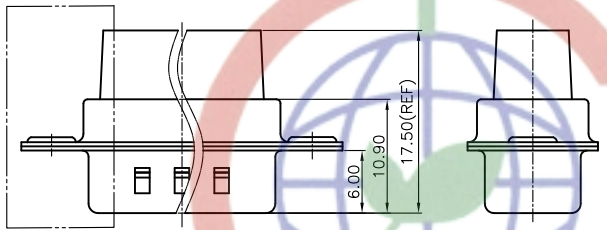

Male terminal

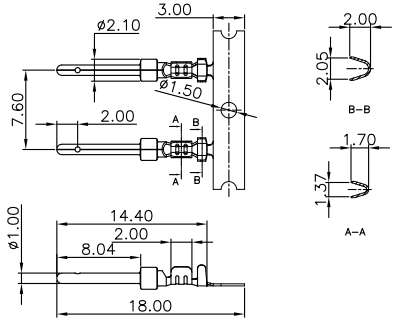

- NOTES:
- ELECTRICAL CHARACTERISTICS:
    - CONTACT RESISTANCE: 20mΩ Max.INITIAL.
    - DIELECTRIC WITHSTANDING VOLTAGE:500V AC(rms) FOR 1 MINUTE.
    - INSULATION RESISTANCE:1000MΩ Min.
  - MECHANICAL CHARACTERISTICS:
    - DURABILITY: 300 CYCLES.
  - ENVIRONMENT CHARACTERISTICS:
    - OPERATING TEMPERATURE:-40°C~+105°C.
  - APPLICATION WIRE AWG:#20-24.
  - PRODUCT NUMBER CODE:

- DS1036-01 - XX X X X X X X
- SCREW DIM. A
    - S: Standard(W/O nut)
    - 1: 3.00 2: 4.00
    - 3: 4.50 4: 5.00
    - 5: 5.50 6: 5.80
  - SCREW TYPE
    - S: Standard(W/O nut)
    - 1: CC TYPE
    - 2: CS TYPE
  - SHELL PLATING
    - T:FORNT&BACK SHELL TIN
    - N:FORNT SHELL NICKEL, BACK SHELL TIN
  - CONTACT PLATING
    - 0:SELECTIVE GOLD FLASH
    - 8:FULL GOLD FLASH
  - HOUSING COLOR
    - U:BLUE B:BLACK
  - CONNECTOR TYPE
    - M:MALE F:FEMALE
  - No.OF CONTACTS
    - 09:9pos 15:15pos
    - 25:25pos 37:37pos

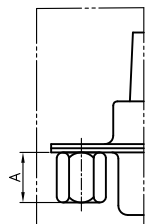

CC TYPE

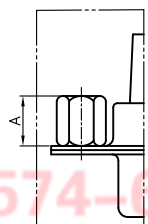

CS TYPE

Female

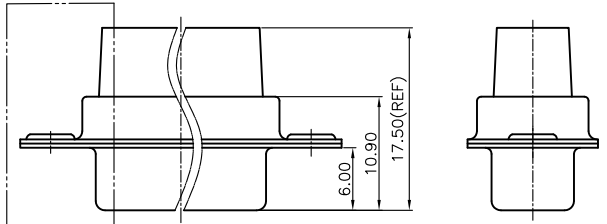

Female terminal

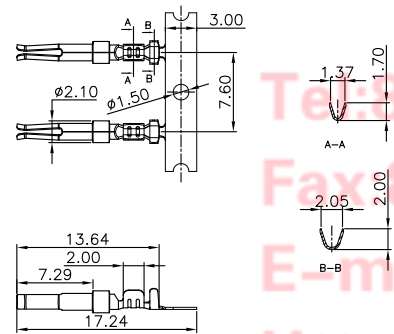

Position	C±0.2	
	Male	Female
9P	30.80	24.99
15P	39.14	33.32
25P	53.04	47.04
37P	69.32	63.50

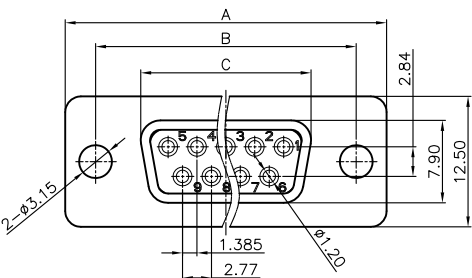

GENERAL TOLERANCE	ANGLE TOLERANCE
X. ±0.60	X. ±3°
.X ±0.38	.X ±2°
.XX ±0.25	.XX ±1°

PROJECTION	TITLE
UNITS mm	D-SUB CRIMP TYPE
SHEET SIZE A4	SERIES DS1036-01 SERIES

DRAWING TYPE	CUSTOMER
SCALE 1:1	SHEET 1 OF 1
DRAWING NO. C-DS1036-01-XXXXXXX	

**晨翔电子有限公司**  
**CONNFLY CONNFLY ELECTRONIC CO. LTD**

Tel: 86-574-63508787  
 Fax: 86-574-63510817  
 E-mail: sale@connfly.com.cn  
 Http://www.connfly.com