

# TLV1543C, TLV1543I, TLV1543M 3.3-V 10-BIT ANALOG-TO-DIGITAL CONVERTERS WITH SERIAL CONTROL AND 11 ANALOG INPUTS

SLAS072E – DECEMBER 1992 – REVISED JANUARY 2004

- 3.3-V Supply Operation
- 10-Bit-Resolution A/D Converter
- 11 Analog Input Channels
- Three Built-In Self-Test Modes
- Inherent Sample and Hold
- Total Unadjusted Error . . .  $\pm 1$  LSB Max
- On-Chip System Clock
- End-of-Conversion (EOC) Output
- Pin Compatible With TLC1543
- CMOS Technology

## description

The TLV1543C, TLV1543I, and TLV1543M are CMOS 10-bit, switched-capacitor, successive-approximation, analog-to-digital converters. These devices have three inputs and a 3-state output [chip select ( $\overline{CS}$ ), input-output clock (I/O CLOCK), address input (ADDRESS), and data output (DATA OUT)] that provide a direct 4-wire interface to the serial port of a host processor. The devices allow high-speed data transfers from the host.

In addition to a high-speed A/D converter and versatile control capability, these devices have an on-chip 14-channel multiplexer that can select any one of 11 analog inputs or any one of three internal self-test voltages. The sample-and-hold function is automatic. At the end of A/D conversion, the end-of-conversion (EOC) output goes high to indicate that conversion is complete. The converter incorporated in the devices features differential high-impedance reference inputs that facilitate ratiometric conversion, scaling, and isolation of analog circuitry from logic and supply noise. A switched-capacitor design allows low-error conversion over the full operating free-air temperature range.

The TLV1543C is characterized for operation from 0°C to 70°C. The TLV1543I is characterized for industrial temperature range of -40°C to 85°C. The TLV1543M is characterized for operation over the full military temperature range of -55°C to 125°C.

DB, DW, FK, J, OR N PACKAGE  
(TOP VIEW)

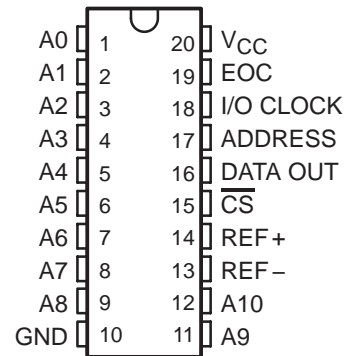

FN PACKAGE  
(TOP VIEW)

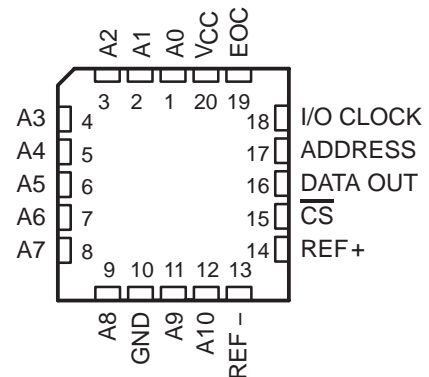

## AVAILABLE OPTIONS

T <sub>A</sub>	PACKAGE					
	SMALL OUTLINE (DB)	SMALL OUTLINE (DW)	CHIP CARRIER (FK)	CERAMIC DIP (J)	PLASTIC DIP (N)	PLASTIC CHIP CARRIER (FN)
0°C to 70°C	TLV1543CDB	TLV1543CDW	—	—	TLV1543CN	TLV1543CFN
-40°C to 85°C	TLV1543IDB	—	—	—	—	—
-55°C to 125°C	—	—	TLV1543MFK	TLV1543MJ	—	—



Please be aware that an important notice concerning availability, standard warranty, and use in critical applications of Texas Instruments semiconductor products and disclaimers thereto appears at the end of this data sheet.

PRODUCTION DATA information is current as of publication date. Products conform to specifications per the terms of Texas Instruments standard warranty. Production processing does not necessarily include testing of all parameters.

 **TEXAS  
INSTRUMENTS**  
WWW.TI.COM

Copyright © 2000 – 2004, Texas Instruments Incorporated

# TLV1543C, TLV1543I, TLV1543M

## 3.3-V 10-BIT ANALOG-TO-DIGITAL CONVERTERS WITH SERIAL CONTROL AND 11 ANALOG INPUTS

SLAS072E – DECEMBER 1992 – REVISED JANUARY 2004

### functional block diagram

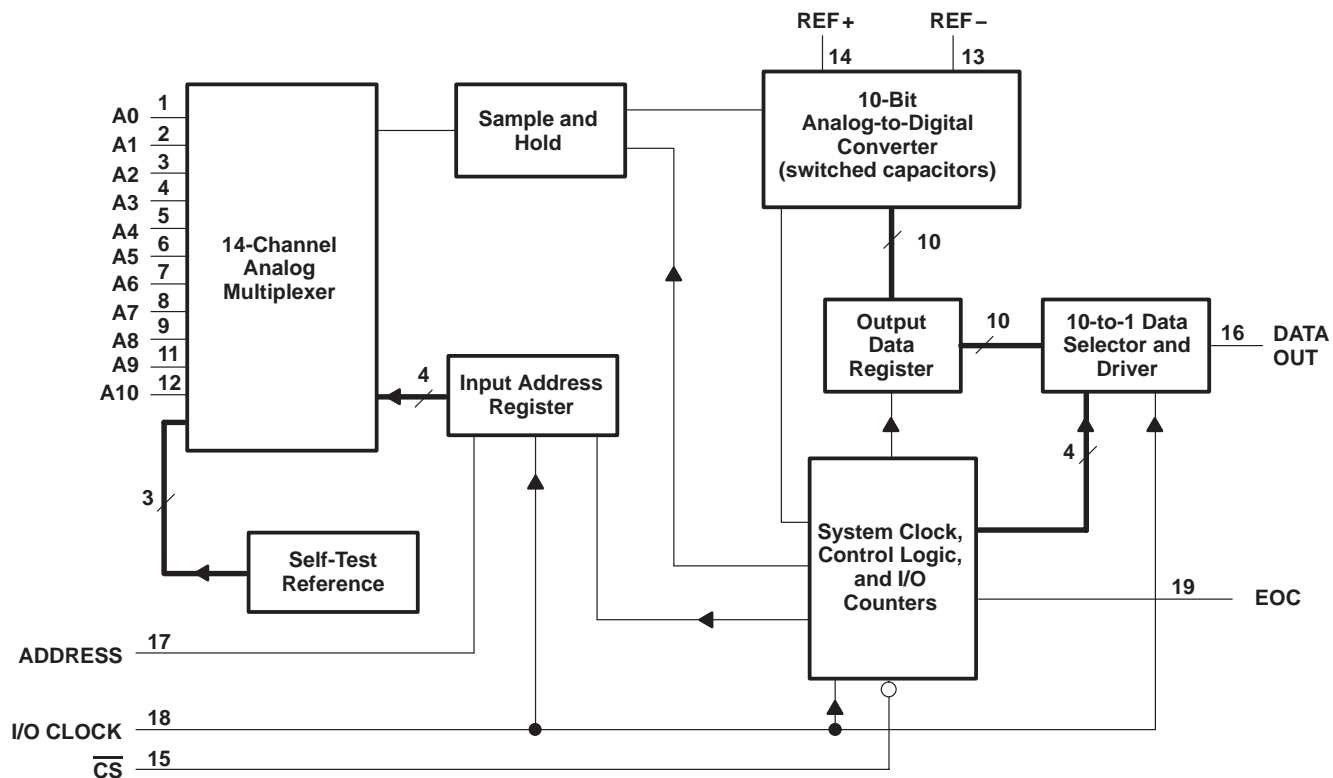

### typical equivalent inputs

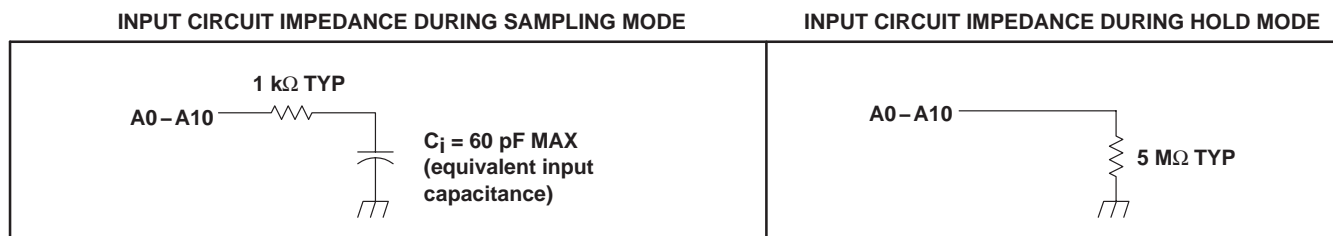

**TLV1543C, TLV1543I, TLV1543M**  
**3.3-V 10-BIT ANALOG-TO-DIGITAL CONVERTERS**  
**WITH SERIAL CONTROL AND 11 ANALOG INPUTS**

SLAS072E – DECEMBER 1992 – REVISED JANUARY 2004

**Terminal Functions**

TERMINAL NAME	NO.	I/O	DESCRIPTION
ADDRESS	17	I	Serial address. A 4-bit serial address selects the desired analog input or test voltage that is to be converted next. The address data is presented with the MSB first and is shifted in on the first four rising edges of I/O CLOCK. After the four address bits have been read into the address register, ADDRESS is ignored for the remainder of the current conversion period.
A0–A10	1–9, 11, 12	I	Analog signal. The 11 analog inputs are applied to A0–A10 and are internally multiplexed. The driving source impedance should be less than or equal to 1 k $\Omega$ .
$\overline{\text{CS}}$	15	I	Chip select. A high-to-low transition on $\overline{\text{CS}}$ resets the internal counters and controls and enables DATA OUT, ADDRESS, and I/O CLOCK within a maximum of a setup time plus two falling edges of the internal system clock. A low-to-high transition disables ADDRESS and I/O CLOCK within a setup time plus two falling edges of the internal system clock.
DATA OUT	16	O	The 3-state serial output for the A/D conversion result. DATA OUT is in the high-impedance state when $\overline{\text{CS}}$ is high and active when $\overline{\text{CS}}$ is low. With a valid chip select, DATA OUT is removed from the high-impedance state and is driven to the logic level corresponding to the MSB value of the previous conversion result. The next falling edge of I/O CLOCK drives DATA OUT to the logic level corresponding to the next most significant bit, and the remaining bits are shifted out in order with the LSB appearing on the ninth falling edge of I/O CLOCK. On the tenth falling edge of I/O CLOCK, DATA OUT is driven to a low logic level so that serial interface data transfers of more than ten clocks produce zeroes as the unused LSBs.
EOC	19	O	End of conversion. EOC goes from a high- to a low- logic level on the trailing edge of the tenth I/O CLOCK and remains low until the conversion is complete and data are ready for transfer.
GND	10	I	The ground return terminal for the internal circuitry. Unless otherwise noted, all voltage measurements are with respect to GND.
I/O CLOCK	18	I	Input/output clock. I/O CLOCK receives the serial I/O CLOCK input and performs the following four functions: 1) It clocks the four input address bits into the address register on the first four rising edges of I/O CLOCK with the multiplex address available after the fourth rising edge. 2) On the fourth falling edge of I/O CLOCK, the analog input voltage on the selected multiplex input begins charging the capacitor array and continues to do so until the tenth falling edge of I/O CLOCK. 3) It shifts the nine remaining bits of the previous conversion data out on DATA OUT. 4) It transfers control of the conversion to the internal state controller on the falling edge of the tenth clock.
REF +	14	I	The upper reference voltage value (nominally $V_{\text{CC}}$ ) is applied to REF +. The maximum input voltage range is determined by the difference between the voltage applied to REF + and the voltage applied to the REF – terminal.
REF –	13	I	The lower reference voltage value (nominally ground) is applied to REF –.
$V_{\text{CC}}$	20	I	Positive supply voltage

**detailed description**

With chip select ( $\overline{\text{CS}}$ ) inactive (high), the ADDRESS and I/O CLOCK inputs are initially disabled and DATA OUT is in the high-impedance state. When the serial interface takes  $\overline{\text{CS}}$  active (low), the conversion sequence begins with the enabling of I/O CLOCK and ADDRESS and the removal of DATA OUT from the high-impedance state. The host then provides the 4-bit channel address to ADDRESS and the I/O CLOCK sequence to I/O CLOCK. During this transfer, the host serial interface also receives the previous conversion result from DATA OUT. I/O CLOCK receives an input sequence that is between 10 and 16 clocks long from the host. The first four I/O clocks load the address register with the 4-bit address on ADDRESS selecting the desired analog channel and the next six clocks providing the control timing for sampling the analog input.

**TLV1543C, TLV1543I, TLV1543M**  
**3.3-V 10-BIT ANALOG-TO-DIGITAL CONVERTERS**  
**WITH SERIAL CONTROL AND 11 ANALOG INPUTS**

SLAS072E – DECEMBER 1992 – REVISED JANUARY 2004

**detailed description (continued)**

There are six basic serial interface timing modes that can be used with the device. These modes are determined by the speed of I/O CLOCK and the operation of  $\overline{CS}$  as shown in Table 1. These modes are (1) a fast mode with a 10-clock transfer and  $\overline{CS}$  inactive (high) between conversion cycles, (2) a fast mode with a 10-clock transfer and  $\overline{CS}$  active (low) continuously, (3) a fast mode with an 11- to 16-clock transfer and  $\overline{CS}$  inactive (high) between conversion cycles, (4) a fast mode with a 16-bit transfer and  $\overline{CS}$  active (low) continuously, (5) a slow mode with an 11- to 16-clock transfer and  $\overline{CS}$  inactive (high) between conversion cycles, and (6) a slow mode with a 16-clock transfer and  $\overline{CS}$  active (low) continuously.

The MSB of the previous conversion appears on DATA OUT on the falling edge of  $\overline{CS}$  in mode 1, mode 3, and mode 5, on the rising edge of EOC in mode 2 and mode 4, and following the 16th clock falling edge in mode 6. The remaining nine bits are shifted out on the next nine falling edges of I/O CLOCK. Ten bits of data are transmitted to the host through DATA OUT. The number of serial clock pulses used also depends on the mode of operation, but a minimum of ten clock pulses is required for conversion to begin. On the 10th clock falling edge, the EOC output goes low and returns to the high logic level when conversion is complete and the result can be read by the host. On the 10th clock falling edge, the internal logic takes DATA OUT low to ensure that the remaining bit values are zero if the I/O CLOCK transfer is more than ten clocks long.

Table 1 lists the operational modes with respect to the state of  $\overline{CS}$ , the number of I/O serial transfer clocks that can be used, and the timing edge on which the MSB of the previous conversion appears at the output.

**Table 1. Mode Operation**

MODES		$\overline{CS}$	NO. OF I/O CLOCKS	MSB AT DATA OUT†	TIMING DIAGRAM
Fast Modes	Mode 1	High between conversion cycles	10	$\overline{CS}$ falling edge	Figure 9
	Mode 2	Low continuously	10	EOC rising edge	Figure 10
	Mode 3	High between conversion cycles	11 to 16‡	$\overline{CS}$ falling edge	Figure 11
	Mode 4	Low continuously	16‡	EOC rising edge	Figure 12
Slow Modes	Mode 5	High between conversion cycles	11 to 16‡	$\overline{CS}$ falling edge	Figure 13
	Mode 6	Low continuously	16‡	16th clock falling edge	Figure 14

† These edges also initiate serial-interface communication.

‡ No more than 16 clocks should be used.

**fast modes**

The device is in a fast mode when the serial I/O CLOCK data transfer is completed before the conversion is completed. With a 10-clock serial transfer, the device can only run in a fast mode since a conversion does not begin until the falling edge of the 10th I/O CLOCK.

**mode 1: fast mode,  $\overline{CS}$  inactive (high) between conversion cycles, 10-clock transfer**

In this mode,  $\overline{CS}$  is inactive (high) between serial I/O CLOCK transfers and each transfer is ten clocks long. The falling edge of  $\overline{CS}$  begins the sequence by removing DATA OUT from the high-impedance state. The rising edge of  $\overline{CS}$  ends the sequence by returning DATA OUT to the high-impedance state within the specified delay time. Also, the rising edge of  $\overline{CS}$  disables the I/O CLOCK and ADDRESS terminals within a setup time plus two falling edges of the internal system clock.

**mode 2: fast mode,  $\overline{CS}$  active (low) continuously, 10-clock transfer**

In this mode,  $\overline{CS}$  is active (low) between serial I/O CLOCK transfers and each transfer is ten clocks long. After the initial conversion cycle,  $\overline{CS}$  is held active (low) for subsequent conversions; the rising edge of EOC then begins each sequence by removing DATA OUT from the low logic level, allowing the MSB of the previous conversion to appear immediately on this output.

**mode 3: fast mode,  $\overline{CS}$  inactive (high) between conversion cycles, 11- to 16-clock transfer**

In this mode,  $\overline{CS}$  is inactive (high) between serial I/O CLOCK transfers and each transfer can be 11 to 16 clocks long. The falling edge of  $\overline{CS}$  begins the sequence by removing DATA OUT from the high-impedance state. The rising edge of  $\overline{CS}$  ends the sequence by returning DATA OUT to the high-impedance state within the specified delay time. Also, the rising edge of  $\overline{CS}$  disables the I/O CLOCK and ADDRESS terminals within a setup time plus two falling edges of the internal system clock.

**mode 4: fast mode,  $\overline{CS}$  active (low) continuously, 16-clock transfer**

In this mode,  $\overline{CS}$  is active (low) between serial I/O CLOCK transfers and each transfer must be exactly 16 clocks long. After the initial conversion cycle,  $\overline{CS}$  is held active (low) for subsequent conversions; the rising edge of EOC then begins each sequence by removing DATA OUT from the low logic level, allowing the MSB of the previous conversion to appear immediately on this output.

**slow modes**

In a slow mode, the conversion is completed before the serial I/O CLOCK data transfer is completed. A slow mode requires a minimum 11-clock transfer into I/O CLOCK, and the rising edge of the eleventh clock must occur before the conversion period is complete; otherwise, the device loses synchronization with the host serial interface, and  $\overline{CS}$  has to be toggled to initialize the system. The eleventh rising edge of the I/O CLOCK must occur within 9.5  $\mu$ s after the tenth I/O clock falling edge.

**mode 5: slow mode,  $\overline{CS}$  inactive (high) between conversion cycles, 11- to 16-clock transfer**

In this mode,  $\overline{CS}$  is inactive (high) between serial I/O CLOCK transfers and each transfer can be 11 to 16 clocks long. The falling edge of  $\overline{CS}$  begins the sequence by removing DATA OUT from the high-impedance state. The rising edge of  $\overline{CS}$  ends the sequence by returning DATA OUT to the high-impedance state within the specified delay time. Also, the rising edge of  $\overline{CS}$  disables the I/O CLOCK and ADDRESS terminals within a setup time plus two falling edges of the internal system clock.

**mode 6: slow mode,  $\overline{CS}$  active (low) continuously, 16-clock transfer**

In this mode,  $\overline{CS}$  is active (low) between serial I/O CLOCK transfers and each transfer must be exactly 16 clocks long. After the initial conversion cycle,  $\overline{CS}$  is held active (low) for subsequent conversions. The falling edge of the sixteenth I/O CLOCK then begins each sequence by removing DATA OUT from the low state, allowing the MSB of the previous conversion to appear immediately at DATA OUT. The device is then ready for the next 16-clock transfer initiated by the serial interface.

**address bits**

The 4-bit analog channel-select address for the next conversion cycle is presented to the ADDRESS terminal (MSB first) and is clocked into the address register on the first four leading edges of I/O CLOCK. This address selects one of 14 inputs (11 analog inputs or 3 internal test inputs).

**analog inputs and test modes**

The 11 analog inputs and the 3 internal test inputs are selected by the 14-channel multiplexer according to the input address as shown in Tables 2 and 3. The input multiplexer is a break-before-make type to reduce input-to-input noise injection resulting from channel switching.

Sampling of the analog input starts on the falling edge of the fourth I/O CLOCK, and sampling continues for six I/O CLOCK periods. The sample is held on the falling edge of the tenth I/O CLOCK. The three test inputs are applied to the multiplexer, sampled, and converted in the same manner as the external analog inputs.

**TLV1543C, TLV1543I, TLV1543M**  
**3.3-V 10-BIT ANALOG-TO-DIGITAL CONVERTERS**  
**WITH SERIAL CONTROL AND 11 ANALOG INPUTS**

SLAS072E – DECEMBER 1992 – REVISED JANUARY 2004

**Table 2. Analog-Channel-Select Address**

ANALOG INPUT SELECTED	VALUE SHIFTED INTO ADDRESS INPUT	
	BINARY	HEX
A0	0000	0
A1	0001	1
A2	0010	2
A3	0011	3
A4	0100	4
A5	0101	5
A6	0110	6
A7	0111	7
A8	1000	8
A9	1001	9
A10	1010	A

**Table 3. Test-Mode-Select Address**

INTERNAL SELF-TEST VOLTAGE SELECTED†	VALUE SHIFTED INTO ADDRESS INPUT		OUTPUT RESULT (HEX)‡
	BINARY	HEX	
$\frac{V_{ref+} - V_{ref-}}{2}$	1011	B	200
$V_{ref-}$	1100	C	000
$V_{ref+}$	1101	D	3FF

†  $V_{ref+}$  is the voltage applied to the REF+ input, and  $V_{ref-}$  is the voltage applied to the REF- input.

‡ The output results shown are the ideal values and vary with the reference stability and with internal offsets.

**converter and analog input**

The CMOS threshold detector in the successive-approximation conversion system determines each bit by examining the charge on a series of binary-weighted capacitors (see Figure 1). In the first phase of the conversion process, the analog input is sampled by closing the  $S_C$  switch and all  $S_T$  switches simultaneously. This action charges all the capacitors to the input voltage.

In the next phase of the conversion process, all  $S_T$  and  $S_C$  switches are opened and the threshold detector begins identifying bits by identifying the charge (voltage) on each capacitor relative to the reference (REF-) voltage. In the switching sequence, ten capacitors are examined separately until all ten bits are identified and the charge-convert sequence is repeated. In the first step of the conversion phase, the threshold detector looks at the first capacitor (weight = 512). Node 512 of this capacitor is switched to the REF+ voltage, and the equivalent nodes of all the other capacitors on the ladder are switched to REF-. If the voltage at the summing node is greater than the trip point of the threshold detector (approximately one-half the  $V_{CC}$  voltage), a bit 0 is placed in the output register and the 512-weight capacitor is switched to REF-. If the voltage at the summing node is less than the trip point of the threshold detector, a bit 1 is placed in the register and the 512-weight capacitor remains connected to REF+ through the remainder of the successive-approximation process. The process is repeated for the 256-weight capacitor, the 128-weight capacitor, and so forth down the line until all bits are counted.

With each step of the successive-approximation process, the initial charge is redistributed among the capacitors. The conversion process relies on charge redistribution to count and weigh the bits from MSB to LSB.

**converter and analog input (continued)**

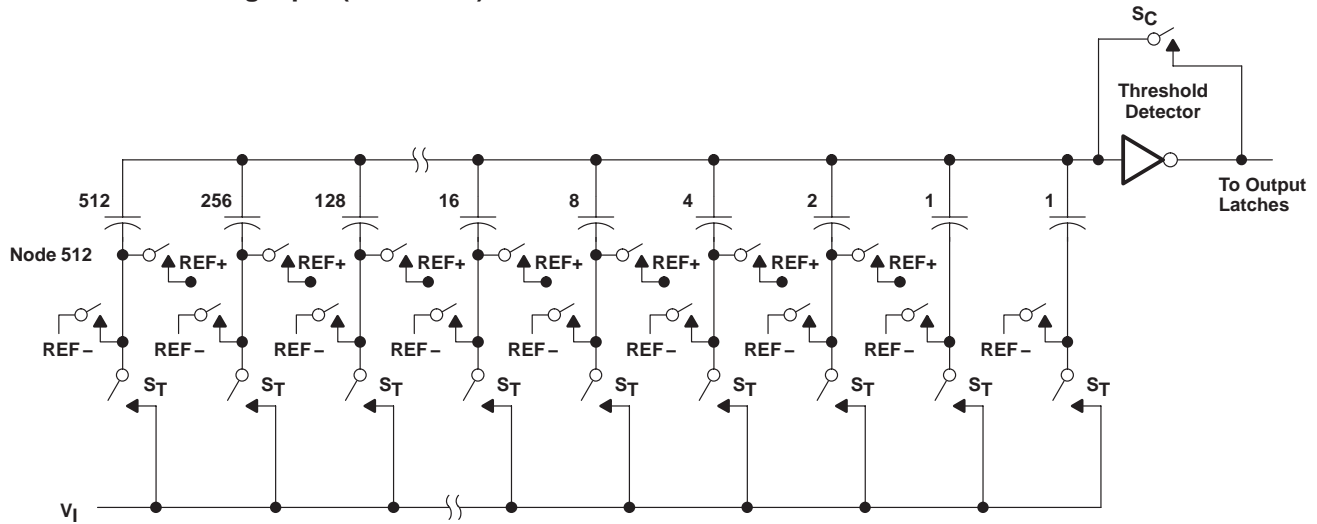

**Figure 1. Simplified Model of the Successive-Approximation System**

**chip-select operation**

The trailing edge of  $\overline{CS}$  starts all modes of operation, and  $\overline{CS}$  can abort a conversion sequence in any mode. A high-to-low transition on  $\overline{CS}$  within the specified time during an ongoing cycle aborts the cycle, and the device returns to the initial state (the contents of the output data register remain at the previous conversion result). Exercise care to prevent  $\overline{CS}$  from being taken low close to completion of conversion because the output data can be corrupted.

**reference voltage inputs**

There are two reference inputs used with these devices: REF+ and REF-. These voltage values establish the upper and lower limits of the analog input to produce a full-scale and zero-scale reading respectively. The values of REF+, REF-, and the analog input should not exceed the positive supply or be lower than GND consistent with the specified absolute maximum ratings. The digital output is at full scale when the input signal is equal to or higher than REF+ and at zero when the input signal is equal to or lower than REF-.

**absolute maximum ratings over operating free-air temperature range (unless otherwise noted)†**

Supply voltage range, $V_{CC}$ (see Note 1): TLV1543C/TLV1543I .....	-0.5 V to 6.5 V
TLV1543M .....	-0.5 V to 6 V
Input voltage range, $V_I$ (any input) .....	-0.3 V to $V_{CC} + 0.3$ V
Output voltage range, $V_O$ .....	-0.3 V to $V_{CC} + 0.3$ V
Positive reference voltage, $V_{ref+}$ .....	$V_{CC} + 0.1$ V
Negative reference voltage, $V_{ref-}$ .....	-0.1 V
Peak input current (any input), $I_{(p-p)}$ .....	$\pm 20$ mA
Peak total input current (all inputs), $I_p$ .....	$\pm 30$ mA
Operating free-air temperature range, $T_A$ : TLV1543C .....	0°C to 70°C
TLV1543I .....	-40°C to 85°C
TLV1543M .....	-55°C to 125°C
Storage temperature range, $T_{stg}$ .....	-65°C to 150°C
Lead temperature 1,6 mm (1/16 inch) from the case for 10 seconds .....	260°C

† Stresses beyond those listed under "absolute maximum ratings" may cause permanent damage to the device. These are stress ratings only, and functional operation of the device at these or any other conditions beyond those indicated under "recommended operating conditions" is not implied. Exposure to absolute-maximum-rated conditions for extended periods may affect device reliability.

NOTE 1: All voltage values are with respect to digital ground with REF- and GND wired together (unless otherwise noted).

# TLV1543C, TLV1543I, TLV1543M

## 3.3-V 10-BIT ANALOG-TO-DIGITAL CONVERTERS WITH SERIAL CONTROL AND 11 ANALOG INPUTS

SLAS072E – DECEMBER 1992 – REVISED JANUARY 2004

### recommended operating conditions

		MIN	NOM	MAX	UNIT
Supply voltage, $V_{CC}$	TLV1543C/TLV1543I	3	3.3	5.5	V
	TLV1543M	3	3.3	3.6	V
Positive reference voltage, $V_{ref+}$ (see Note 2)		$V_{CC}$			V
Negative reference voltage, $V_{ref-}$ (see Note 2)		0			V
Differential reference voltage, $V_{ref+} - V_{ref-}$ (see Note 2)		2.5	$V_{CC}$	$V_{CC}+0.2$	V
Analog input voltage (see Note 2)		0			$V_{CC}$
High-level control input voltage, $V_{IH}$	TLV1543C/TLV1543I	$V_{CC} = 3\text{ V to }5.5\text{ V}$		2	V
	TLV1543M	$V_{CC} = 3\text{ V to }3.6\text{ V}$		2	V
Low-level control input voltage, $V_{IL}$	TLV1543C/TLV1543I	$V_{CC} = 3\text{ V to }5.5\text{ V}$		0.6	V
	TLV1543M	$V_{CC} = 3\text{ V to }3.6\text{ V}$		0.8	V
Setup time, address bits at data input before I/O CLOCK $\uparrow$ , $t_{su(A)}$ (see Figure 4)		100			ns
Hold time, address bits after I/O CLOCK $\uparrow$ , $t_h(A)$ (see Figure 4)		0			ns
Hold time, $\overline{CS}$ low after last I/O CLOCK $\downarrow$ , $t_h(CS)$		0			ns
Setup time, $\overline{CS}$ low before clocking in first address bit, $t_{su(CS)}$ (see Note 3)		1.425			$\mu\text{s}$
Clock frequency at I/O CLOCK (see Note 4)	TLV1543C/TLV1543I	0		1.1	MHz
	TLV1543M	0		2.1	
Pulse duration, I/O CLOCK high, $t_{w(H\ I/O)}$		190			ns
Pulse duration, I/O CLOCK low, $t_{w(L\ I/O)}$		190			ns
Transition time, I/O CLOCK, $t_t(I/O)$ (see Note 5)		1			$\mu\text{s}$
Transition time, ADDRESS and $\overline{CS}$ , $t_t(CS)$		10			$\mu\text{s}$
Operating free-air temperature, $T_A$	TLV1543C	0		70	$^{\circ}\text{C}$
	TLV1543I	-40		85	
	TLV1543M	-55		125	

- NOTES: 2. Analog input voltages greater than that applied to REF+ convert as all ones (1111111111), while input voltages less than that applied to REF- convert as all zeros (0000000000).
3. To minimize errors caused by noise at  $\overline{CS}$ , the internal circuitry waits for a setup time plus two falling edges of the internal system clock after  $\overline{CS}\downarrow$  before responding to control input signals. No attempt should be made to clock in an address until the minimum  $\overline{CS}$  setup time has elapsed.
4. For 11- to 16-bit transfers, after the tenth I/O CLOCK falling edge ( $\leq 2\text{ V}$ ), at least one I/O clock rising edge ( $\geq 2\text{ V}$ ) must occur within 9.5  $\mu\text{s}$ .
5. This is the time required for the clock input signal to fall from  $V_{IHmin}$  to  $V_{ILmax}$  or to rise from  $V_{ILmax}$  to  $V_{IHmin}$ . In the vicinity of normal room temperature, the devices function with input clock transition time as slow as 1  $\mu\text{s}$  for remote data-acquisition applications where the sensor and the A/D converter are placed several feet away from the controlling microprocessor.



**TLV1543C, TLV1543I, TLV1543M**  
**3.3-V 10-BIT ANALOG-TO-DIGITAL CONVERTERS**  
**WITH SERIAL CONTROL AND 11 ANALOG INPUTS**

SLAS072E – DECEMBER 1992 – REVISED JANUARY 2004

electrical characteristics over recommended operating free-air temperature range,  
 $V_{CC} = V_{ref+} = 3\text{ V to }5.5\text{ V}$ , I/O CLOCK frequency = 1.1 MHz for the TLV1543C, and TLV1543I  
 $V_{CC} = V_{ref+} = 3\text{ V to }3.6\text{ V}$ , I/O CLOCK frequency = 2.1 MHz for the TLV1543M (unless otherwise noted)

PARAMETER		TEST CONDITIONS	MIN	TYP†	MAX	UNIT
$V_{OH}$ High-level output voltage	TLV1543C/TLV1543I	$V_{CC} = 3\text{ V}$ , $I_{OH} = -1.6\text{ mA}$	2.4			V
		$V_{CC} = 3\text{ V to }5.5\text{ V}$ , $I_{OH} = 20\text{ }\mu\text{A}$	$V_{CC} - 0.1$			V
	TLV1543M	$V_{CC} = 3\text{ V}$ , $I_{OH} = -1.6\text{ mA}$	2.4			V
		$V_{CC} = 3\text{ V to }3.6\text{ V}$ , $I_{OH} = 20\text{ }\mu\text{A}$	$V_{CC} - 0.1$			V
$V_{OL}$ Low-level output voltage	TLV1543C/TLV1543I	$V_{CC} = 3\text{ V}$ , $I_{OL} = 1.6\text{ mA}$			0.4	V
		$V_{CC} = 3\text{ V to }5.5\text{ V}$ , $I_{OL} = 20\text{ }\mu\text{A}$			0.1	V
	TLV1543M	$V_{CC} = 3\text{ V}$ , $I_{OL} = 1.6\text{ mA}$			0.4	V
		$V_{CC} = 3\text{ V to }3.6\text{ V}$ , $I_{OL} = 20\text{ }\mu\text{A}$			0.1	V
$I_{OZ}$ Off-state (high-impedance-state) output current		$V_O = V_{CC}$ , $\overline{CS}$ at $V_{CC}$			10	$\mu\text{A}$
		$V_O = 0$ , $\overline{CS}$ at $V_{CC}$			-10	$\mu\text{A}$
$I_{IH}$ High-level input current		$V_I = V_{CC}$		0.005	2.5	$\mu\text{A}$
$I_{IL}$ Low-level input current		$V_I = 0$		-0.005	-2.5	$\mu\text{A}$
$I_{CC}$ Operating supply current		$\overline{CS}$ at 0 V		0.8	2.5	mA
Selected channel leakage current		Selected channel at $V_{CC}$ , Unselected channel at 0 V			1	$\mu\text{A}$
		Selected channel at 0 V, Unselected channel at $V_{CC}$			-1	$\mu\text{A}$
Maximum static analog reference current into REF +		$V_{ref+} = V_{CC}$ , $V_{ref-} = \text{GND}$			10	$\mu\text{A}$
$C_i$	Input capacitance, Analog inputs	TLV1543C/TLV1543I		7	60	$\text{pF}$
		TLV1543M		7	60	
	Input capacitance, Control inputs	TLV1543C/TLV1543I		5	60	$\text{pF}$
		TLV1543M		5	60	

† All typical values are at  $V_{CC} = 5\text{ V}$ ,  $T_A = 25^\circ\text{C}$ .

# TLV1543C, TLV1543I, TLV1543M

## 3.3-V 10-BIT ANALOG-TO-DIGITAL CONVERTERS WITH SERIAL CONTROL AND 11 ANALOG INPUTS

SLAS072E – DECEMBER 1992 – REVISED JANUARY 2004

operating characteristics over recommended operating free-air temperature range,  
 $V_{CC} = V_{ref+} = 3\text{ V to }5.5\text{ V}$ , I/O CLOCK frequency = 1.1 MHz for the TLV1543C, and TLV1543I  
 $V_{CC} = V_{ref+} = 3\text{ V to }3.6\text{ V}$ , I/O CLOCK frequency = 2.1 MHz for the TLV1543M

PARAMETER	TEST CONDITIONS	MIN	TYP†	MAX	UNIT
Linearity error (see Note 6)				±1	LSB
Zero error (see Note 7)				±1	LSB
Full-scale error (see Note 7)				±1	LSB
Total unadjusted error (see Note 8)				±1	LSB
Self-test output code (see Table 3 and Note 9)	ADDRESS = 1011		512		
	ADDRESS = 1100		0		
	ADDRESS = 1101		1023		
$t_{c(1)}$ Conversion time	See Figures 9–14			21	μs
$t_{c(2)}$ Total cycle time (access, sample, and conversion)	See Figures 9–14 and Note 10			21 +10 I/O CLOCK periods	μs
$t_{(acq)}$ Channel acquisition time (sample)	See Figures 9–14 and Note 10			6	I/O CLOCK periods
$t_v$ Valid time, DATA OUT remains valid after I/O CLOCK↓	See Figure 6	10			ns
$t_{d(I/O-DATA)}$ Delay time, I/O CLOCK↓ to DATA OUT valid	See Figure 6			240	ns
$t_{d(I/O-EOC)}$ Delay time, tenth I/O CLOCK↓ to EOC↓	See Figure 7		70	240	ns
$t_{d(EOC-DATA)}$ Delay time, EOC↑ to DATA OUT (MSB)	See Figure 8			100	ns
$t_{PZH}, t_{PZL}$ Enable time, $\overline{CS}$ ↓ to DATA OUT (MSB driven)	See Figure 3			1.3	μs
$t_{PHZ}, t_{PLZ}$ Disable time, $\overline{CS}$ ↑ to DATA OUT (high impedance)	See Figure 3			150	ns
$t_r(EOC)$ Rise time, EOC	See Figure 8			300	ns
$t_f(EOC)$ Fall time, EOC	See Figure 7			300	ns
$t_r(\text{bus})$ Rise time, data bus	See Figure 6			300	ns
$t_f(\text{bus})$ Fall time, data bus	See Figure 6			300	ns
$t_{d(I/O-CS)}$ Delay time, tenth I/O CLOCK↓ to $\overline{CS}$ ↓ to abort conversion (see Note 11)				9	μs

† All typical values are at  $T_A = 25^\circ\text{C}$ .

- NOTES:
- Linearity error is the maximum deviation from the best straight line through the A/D transfer characteristics.
  - Zero-scale error is the difference between 000000000 and the converted output for zero input voltage; full-scale error is the difference between 111111111 and the converted output for full-scale input voltage.
  - Total unadjusted error comprises linearity, zero-scale, and full-scale errors.
  - Both the input address and the output codes are expressed in positive logic.
  - I/O CLOCK period =  $1/(\text{I/O CLOCK frequency})$  (see Figure 6).
  - Any transitions of  $\overline{CS}$  are recognized as valid only if the level is maintained for a setup time plus two falling edges of the internal clock (1.425 μs) after the transition.

PARAMETER MEASUREMENT INFORMATION

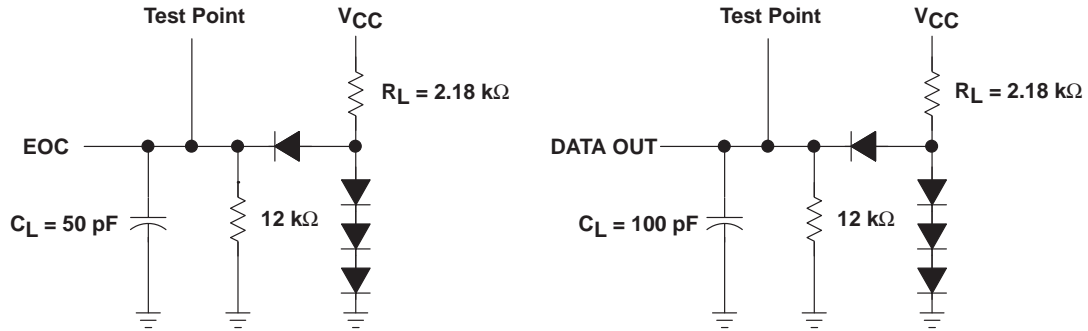

Figure 2. Load Circuits

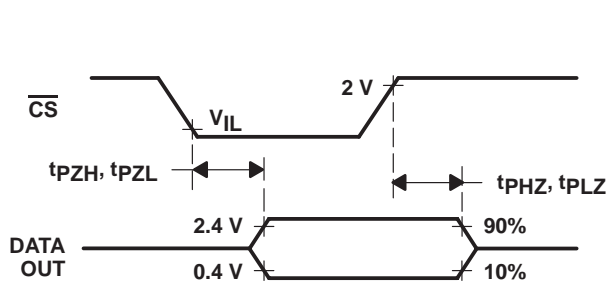

Figure 3. DATA OUT to Hi-Z Voltage Waveforms

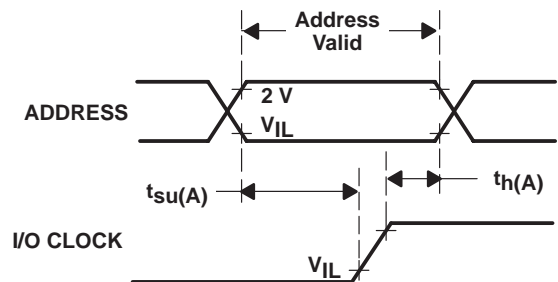

Figure 4. ADDRESS Setup Voltage Waveforms

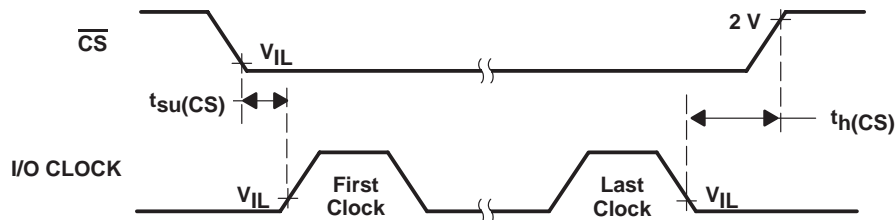
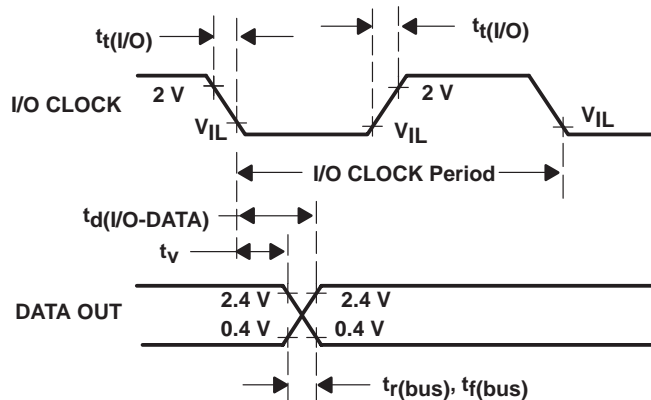

Figure 5.  $\overline{CS}$  and I/O CLOCK Voltage Waveforms

**TLV1543C, TLV1543I, TLV1543M**  
**3.3-V 10-BIT ANALOG-TO-DIGITAL CONVERTERS**  
**WITH SERIAL CONTROL AND 11 ANALOG INPUTS**

SLAS072E – DECEMBER 1992 – REVISED JANUARY 2004

**PARAMETER MEASUREMENT INFORMATION**



**Figure 6. DATA OUT and I/O CLOCK Voltage Waveforms**

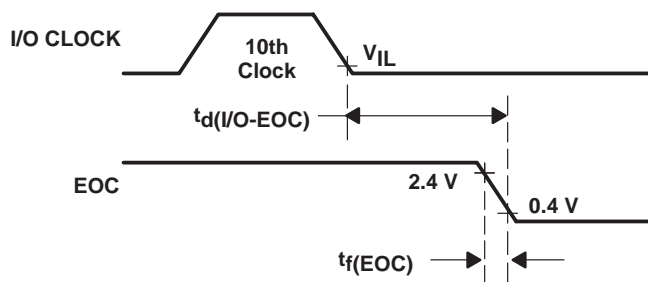

**Figure 7. I/O CLOCK and EOC Voltage Waveforms**

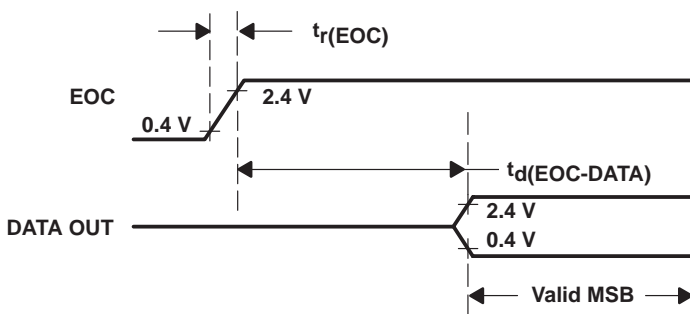

**Figure 8. EOC and DATA OUT Voltage Waveforms**

**TLV1543C, TLV1543I, TLV1543M**  
**3.3-V 10-BIT ANALOG-TO-DIGITAL CONVERTERS**  
**WITH SERIAL CONTROL AND 11 ANALOG INPUTS**

SLAS072E – DECEMBER 1992 – REVISED JANUARY 2004

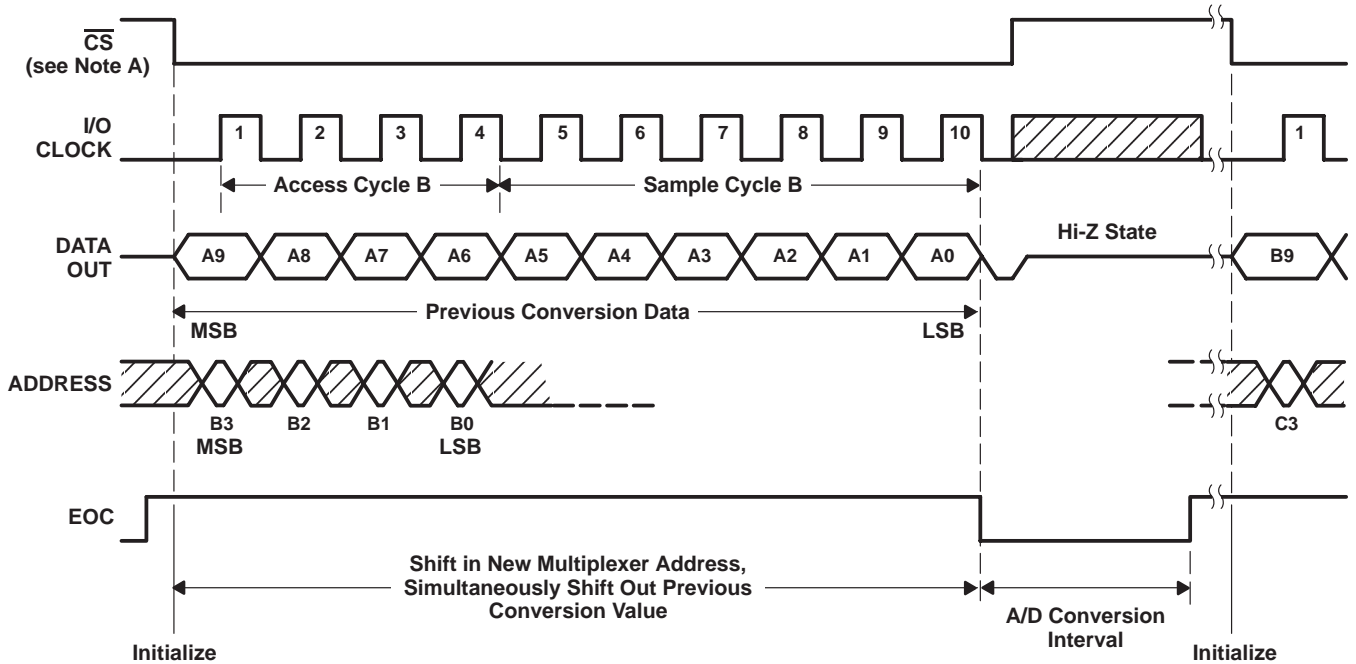

NOTE A: To minimize errors caused by noise at  $\overline{CS}$ , the internal circuitry waits for a setup time plus two falling edges of the internal system clock after  $\overline{CS}\downarrow$  before responding to control input signals. No attempt should be made to clock in an address until the minimum  $\overline{CS}$  setup time has elapsed.

**Figure 9. Timing for 10-Clock Transfer Using  $\overline{CS}$**

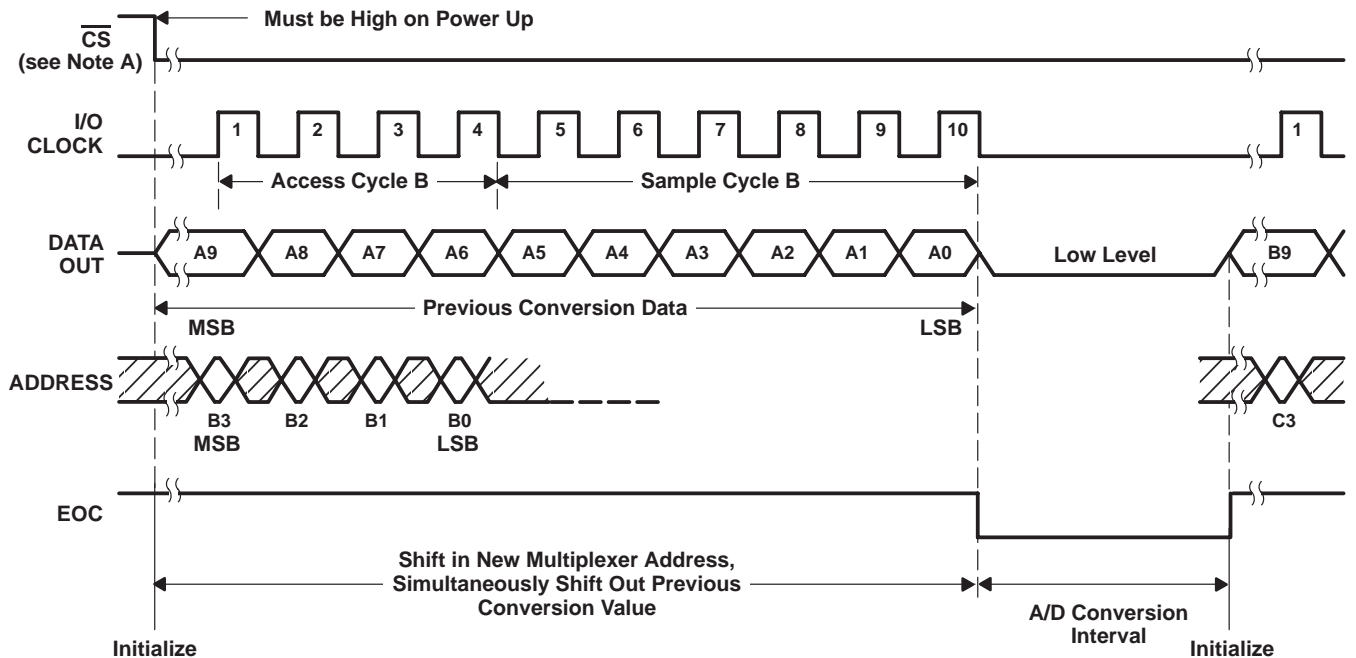

NOTE A: To minimize errors caused by noise at  $\overline{CS}$ , the internal circuitry waits for a setup time plus two falling edges of the internal system clock after  $\overline{CS}\downarrow$  before responding to control input signals. No attempt should be made to clock in an address until the minimum  $\overline{CS}$  setup time has elapsed.

**Figure 10. Timing for 10-Clock Transfer Not Using  $\overline{CS}$**

**TLV1543C, TLV1543I, TLV1543M**  
**3.3-V 10-BIT ANALOG-TO-DIGITAL CONVERTERS**  
**WITH SERIAL CONTROL AND 11 ANALOG INPUTS**

SLAS072E – DECEMBER 1992 – REVISED JANUARY 2004

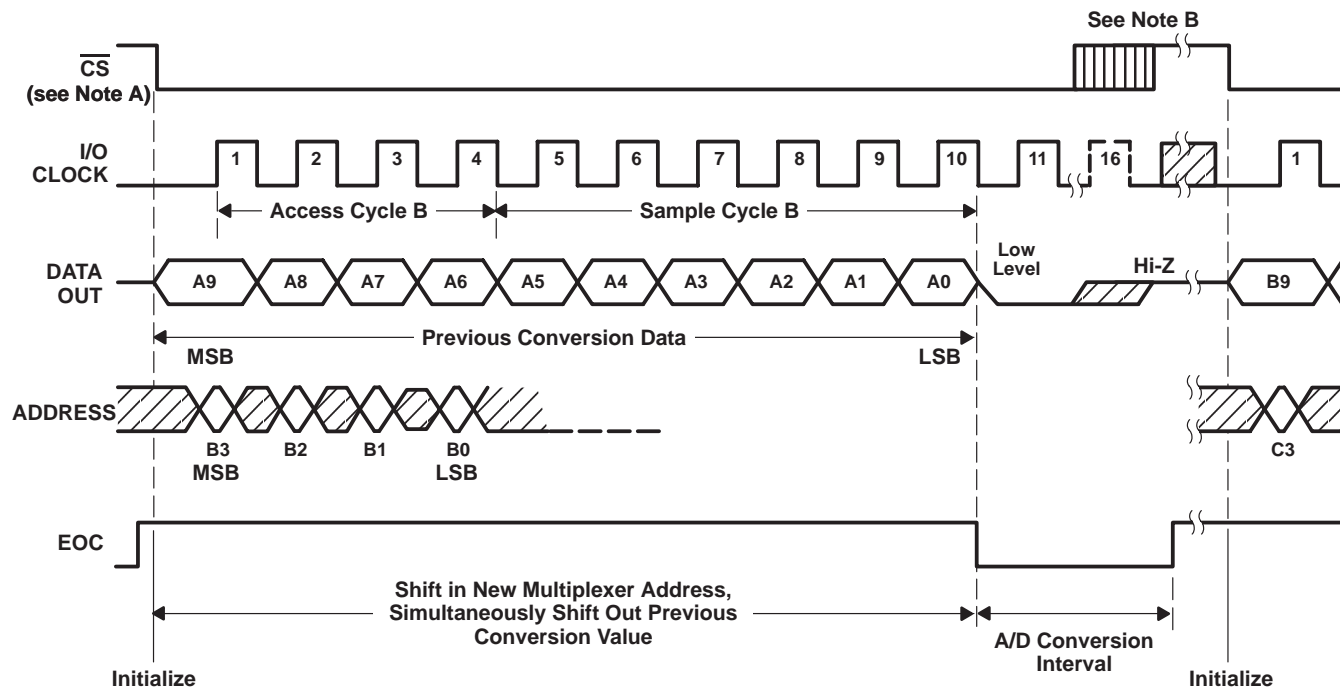

- NOTES: A. To minimize errors caused by noise at  $\overline{CS}$ , the internal circuitry waits for a set up time plus two falling edges of the internal system clock after  $\overline{CS}\downarrow$  before responding to control input signals. No attempt should be made to clock in an address until the minimum  $\overline{CS}$  setup time has elapsed.
- B. A low-to-high transition of  $\overline{CS}$  disables ADDRESS and the I/O CLOCK within a maximum of a setup time plus two falling edges of the internal system clock.

**Figure 11. Timing for 11- to 16-Clock Transfer Using  $\overline{CS}$  (Serial Transfer Interval Shorter Than Conversion)**

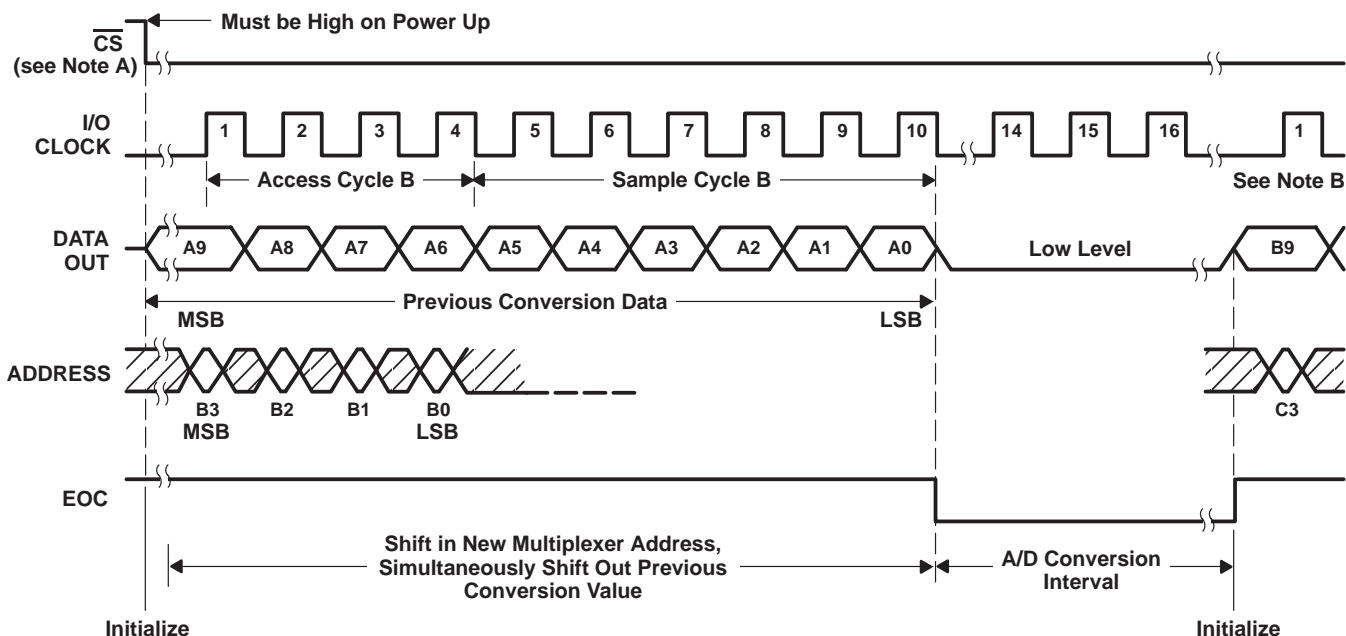

- NOTES: A. The first I/O CLOCK must occur after the rising edge of EOC.
- B. A low-to-high transition of  $\overline{CS}$  disables ADDRESS and the I/O CLOCK within a maximum of a setup time plus two falling edges of the internal system clock.

**Figure 12. Timing for 16-Clock Transfer Not Using  $\overline{CS}$  (Serial Transfer Interval Shorter Than Conversion)**

**TLV1543C, TLV1543I, TLV1543M**  
**3.3-V 10-BIT ANALOG-TO-DIGITAL CONVERTERS**  
**WITH SERIAL CONTROL AND 11 ANALOG INPUTS**

SLAS072E – DECEMBER 1992 – REVISED JANUARY 2004

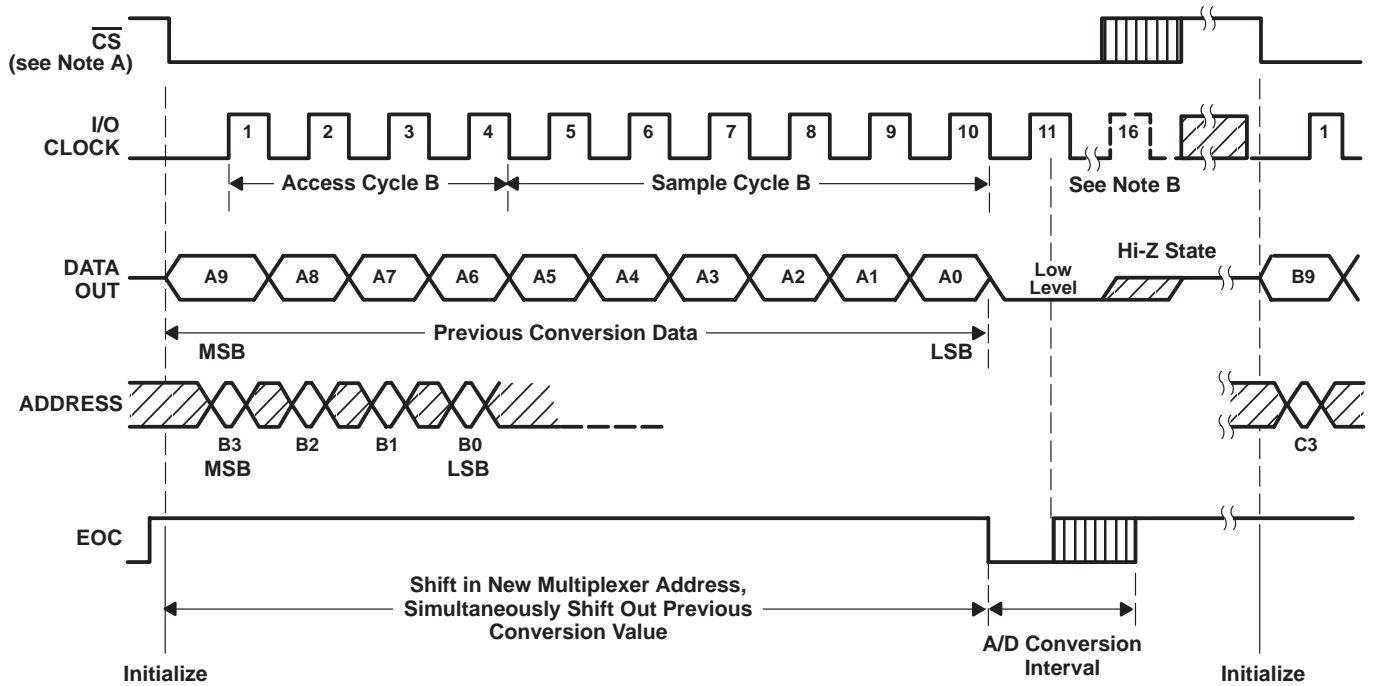

- NOTES: A. To minimize errors caused by noise at  $\overline{CS}$ , the internal circuitry waits for a set up time plus two falling edges of the internal system clock after  $\overline{CS}\downarrow$  before responding to control input signals. No attempt should be made to clock in an address until the minimum chip  $\overline{CS}$  setup time has elapsed.
- B. The eleventh rising edge of the I/O CLOCK sequence must occur before the conversion is complete to prevent losing serial interface synchronization.

**Figure 13. Timing for 11- to 16-Clock Transfer Using  $\overline{CS}$  (Serial Transfer Interval Longer Than Conversion)**

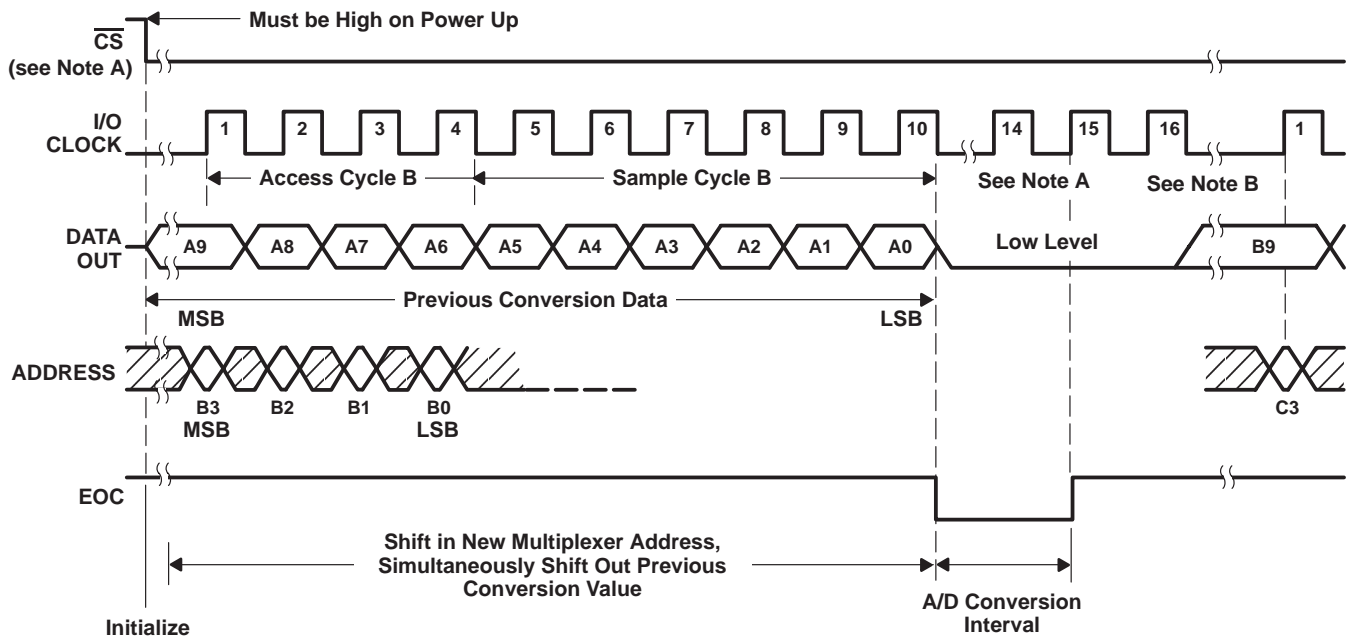

- NOTES: A. The eleventh rising edge of the I/O CLOCK sequence must occur before the conversion is complete to prevent losing serial interface synchronization.
- B. The I/O CLOCK sequence is exactly 16 clock pulses long.

**Figure 14. Timing for 16-Clock Transfer Not Using  $\overline{CS}$  (Serial Transfer Interval Longer Than Conversion)**

**TLV1543C, TLV1543I, TLV1543M**  
**3.3-V 10-BIT ANALOG-TO-DIGITAL CONVERTERS**  
**WITH SERIAL CONTROL AND 11 ANALOG INPUTS**

SLAS072E – DECEMBER 1992 – REVISED JANUARY 2004

**APPLICATION INFORMATION**

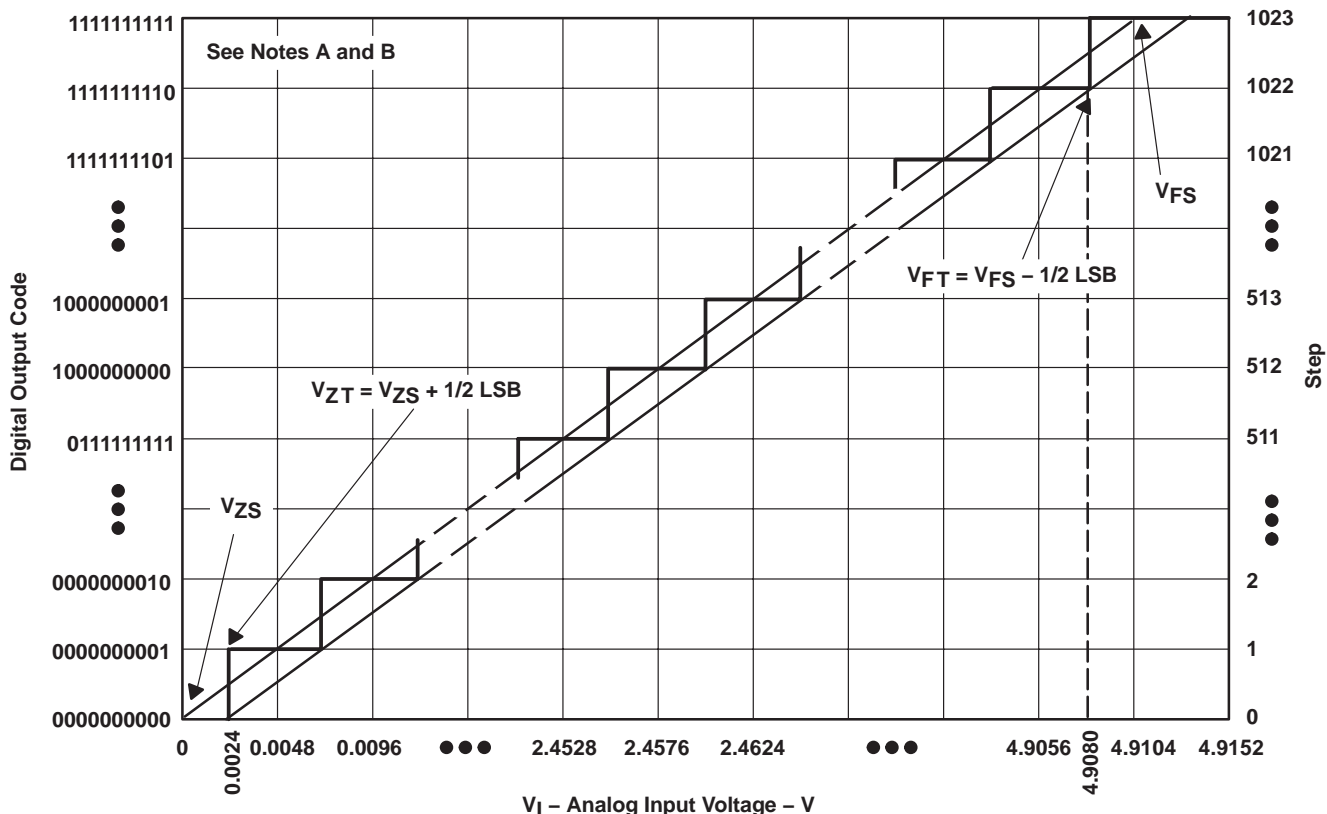

- NOTES: A. This curve is based on the assumption that  $V_{ref+}$  and  $V_{ref-}$  have been adjusted so that the voltage at the transition from digital 0 to 1 ( $V_{ZT}$ ) is 0.0024 V and the transition to full scale ( $V_{FT}$ ) is 4.908 V. 1 LSB = 4.8 mV.  
 B. The full-scale value ( $V_{FS}$ ) is the step whose nominal midstep value has the highest absolute value. The zero-scale value ( $V_{ZS}$ ) is the step whose nominal midstep value equals zero.

**Figure 15. Ideal Conversion Characteristics**

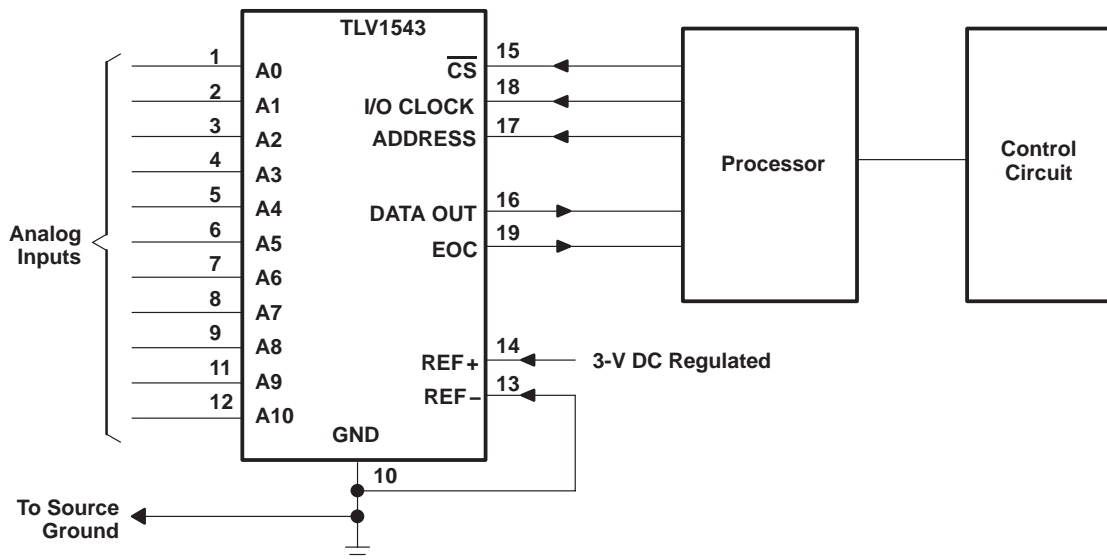

**Figure 16. Serial Interface**



## APPLICATION INFORMATION

### simplified analog input analysis

Using the equivalent circuit in Figure 17, the time required to charge the analog input capacitance from 0 to  $V_S$  within 1/2 LSB can be derived as follows:

The capacitance charging voltage is given by

$$V_C = V_S \left(1 - e^{-t_c/R_t C_i}\right) \quad (1)$$

Where:

$$R_t = R_S + r_i$$

The final voltage to 1/2 LSB is given by

$$V_C (1/2 \text{ LSB}) = V_S - (V_S/2048) \quad (2)$$

Equating equation 1 to equation 2 and solving for time  $t_c$  gives

$$V_S - (V_S/2048) = V_S \left(1 - e^{-t_c/R_t C_i}\right) \quad (3)$$

and

$$t_c (1/2 \text{ LSB}) = R_t \times C_i \times \ln(2048) \quad (4)$$

Therefore, with the values given the time for the analog input signal to settle is

$$t_c (1/2 \text{ LSB}) = (R_S + 1 \text{ k}\Omega) \times 60 \text{ pF} \times \ln(2048) \quad (5)$$

This time must be less than the converter sample time shown in the timing diagrams.

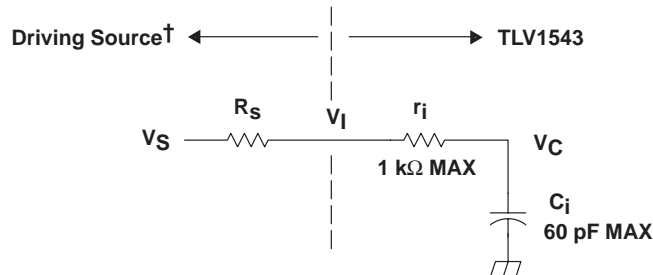

$V_I$  = Input Voltage at A0–A10  
 $V_S$  = External Driving Source Voltage  
 $R_S$  = Source Resistance  
 $r_i$  = Input Resistance  
 $C_i$  = Input Capacitance

† Driving source requirements:

- Noise and distortion for the source must be equivalent to the resolution of the converter.
- $R_S$  must be real at the input frequency.

**Figure 17. Equivalent Input Circuit Including the Driving Source**

**PACKAGING INFORMATION**

Orderable Device	Status (1)	Package Type	Package Drawing	Pins	Package Qty	Eco Plan (2)	Lead/Ball Finish (6)	MSL Peak Temp (3)	Op Temp (°C)	Device Marking (4/5)	Samples
TLV1543CDB	ACTIVE	SSOP	DB	20	70	Green (RoHS & no Sb/Br)	CU NIPDAU	Level-1-260C-UNLIM	-40 to 85	TV1543	<a href="#">Samples</a>
TLV1543CDBR	ACTIVE	SSOP	DB	20	2000	Green (RoHS & no Sb/Br)	CU NIPDAU	Level-1-260C-UNLIM		TV1543	<a href="#">Samples</a>
TLV1543CDW	ACTIVE	SOIC	DW	20	25	Green (RoHS & no Sb/Br)	CU NIPDAU	Level-1-260C-UNLIM		TLV1543C	<a href="#">Samples</a>
TLV1543CDWR	ACTIVE	SOIC	DW	20	2000	Green (RoHS & no Sb/Br)	CU NIPDAU	Level-1-260C-UNLIM		TLV1543C	<a href="#">Samples</a>
TLV1543CDWRG4	ACTIVE	SOIC	DW	20	2000	Green (RoHS & no Sb/Br)	CU NIPDAU	Level-1-260C-UNLIM		TLV1543C	<a href="#">Samples</a>
TLV1543CFN	ACTIVE	PLCC	FN	20	46	Green (RoHS & no Sb/Br)	CU SN	Level-1-260C-UNLIM		TLV1543C	<a href="#">Samples</a>
TLV1543CN	ACTIVE	PDIP	N	20	20	Pb-Free (RoHS)	CU NIPDAU	N / A for Pkg Type		TLV1543CN	<a href="#">Samples</a>
TLV1543IDB	ACTIVE	SSOP	DB	20	70	Green (RoHS & no Sb/Br)	CU NIPDAU	Level-1-260C-UNLIM		TY1543	<a href="#">Samples</a>
TLV1543IDBR	ACTIVE	SSOP	DB	20	2000	Green (RoHS & no Sb/Br)	CU NIPDAU	Level-1-260C-UNLIM		TY1543	<a href="#">Samples</a>

(1) The marketing status values are defined as follows:

**ACTIVE:** Product device recommended for new designs.

**LIFEBUY:** TI has announced that the device will be discontinued, and a lifetime-buy period is in effect.

**NRND:** Not recommended for new designs. Device is in production to support existing customers, but TI does not recommend using this part in a new design.

**PREVIEW:** Device has been announced but is not in production. Samples may or may not be available.

**OBSOLETE:** TI has discontinued the production of the device.

(2) **RoHS:** TI defines "RoHS" to mean semiconductor products that are compliant with the current EU RoHS requirements for all 10 RoHS substances, including the requirement that RoHS substance do not exceed 0.1% by weight in homogeneous materials. Where designed to be soldered at high temperatures, "RoHS" products are suitable for use in specified lead-free processes. TI may reference these types of products as "Pb-Free".

**RoHS Exempt:** TI defines "RoHS Exempt" to mean products that contain lead but are compliant with EU RoHS pursuant to a specific EU RoHS exemption.

**Green:** TI defines "Green" to mean the content of Chlorine (Cl) and Bromine (Br) based flame retardants meet JS709B low halogen requirements of <=1000ppm threshold. Antimony trioxide based flame retardants must also meet the <=1000ppm threshold requirement.

(3) MSL, Peak Temp. - The Moisture Sensitivity Level rating according to the JEDEC industry standard classifications, and peak solder temperature.

(4) There may be additional marking, which relates to the logo, the lot trace code information, or the environmental category on the device.

(5) Multiple Device Markings will be inside parentheses. Only one Device Marking contained in parentheses and separated by a "~" will appear on a device. If a line is indented then it is a continuation of the previous line and the two combined represent the entire Device Marking for that device.

(6) Lead/Ball Finish - Orderable Devices may have multiple material finish options. Finish options are separated by a vertical ruled line. Lead/Ball Finish values may wrap to two lines if the finish value exceeds the maximum column width.

**Important Information and Disclaimer:**The information provided on this page represents TI's knowledge and belief as of the date that it is provided. TI bases its knowledge and belief on information provided by third parties, and makes no representation or warranty as to the accuracy of such information. Efforts are underway to better integrate information from third parties. TI has taken and continues to take reasonable steps to provide representative and accurate information but may not have conducted destructive testing or chemical analysis on incoming materials and chemicals. TI and TI suppliers consider certain information to be proprietary, and thus CAS numbers and other limited information may not be available for release.

In no event shall TI's liability arising out of such information exceed the total purchase price of the TI part(s) at issue in this document sold by TI to Customer on an annual basis.

## TAPE AND REEL INFORMATION



### QUADRANT ASSIGNMENTS FOR PIN 1 ORIENTATION IN TAPE



\*All dimensions are nominal

Device	Package Type	Package Drawing	Pins	SPQ	Reel Diameter (mm)	Reel Width W1 (mm)	A0 (mm)	B0 (mm)	K0 (mm)	P1 (mm)	W (mm)	Pin1 Quadrant
TLV1543CDBR	SSOP	DB	20	2000	330.0	16.4	8.2	7.5	2.5	12.0	16.0	Q1
TLV1543CDWR	SOIC	DW	20	2000	330.0	24.4	10.8	13.3	2.7	12.0	24.0	Q1
TLV1543IDBR	SSOP	DB	20	2000	330.0	16.4	8.2	7.5	2.5	12.0	16.0	Q1

**TAPE AND REEL BOX DIMENSIONS**

\*All dimensions are nominal

Device	Package Type	Package Drawing	Pins	SPQ	Length (mm)	Width (mm)	Height (mm)
TLV1543CDBR	SSOP	DB	20	2000	367.0	367.0	38.0
TLV1543CDWR	SOIC	DW	20	2000	367.0	367.0	45.0
TLV1543IDBR	SSOP	DB	20	2000	367.0	367.0	38.0

DB (R-PDSO-G\*\*)

PLASTIC SMALL-OUTLINE

28 PINS SHOWN



- NOTES: A. All linear dimensions are in millimeters.  
 B. This drawing is subject to change without notice.  
 C. Body dimensions do not include mold flash or protrusion not to exceed 0,15.  
 D. Falls within JEDEC MO-150

**FN 20**

**GENERIC PACKAGE VIEW**

**PLCC - 4.57 mm max height**

PLASTIC CHIP CARRIER

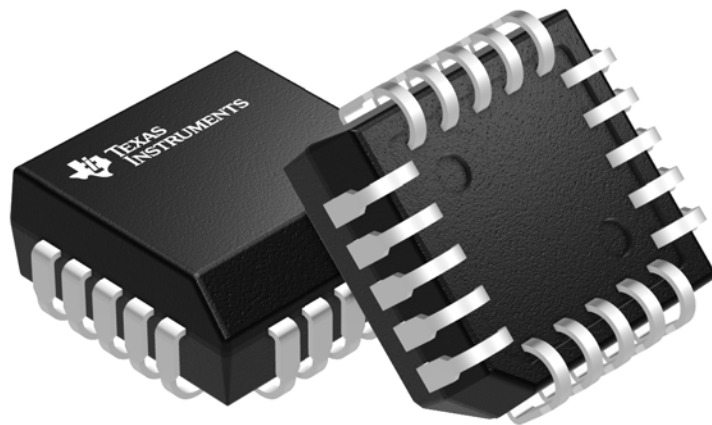

Images above are just a representation of the package family, actual package may vary.  
Refer to the product data sheet for package details.

4040005-2/C



# FN0020A

# PACKAGE OUTLINE

## PLCC - 4.57 mm max height

PLASTIC CHIP CARRIER

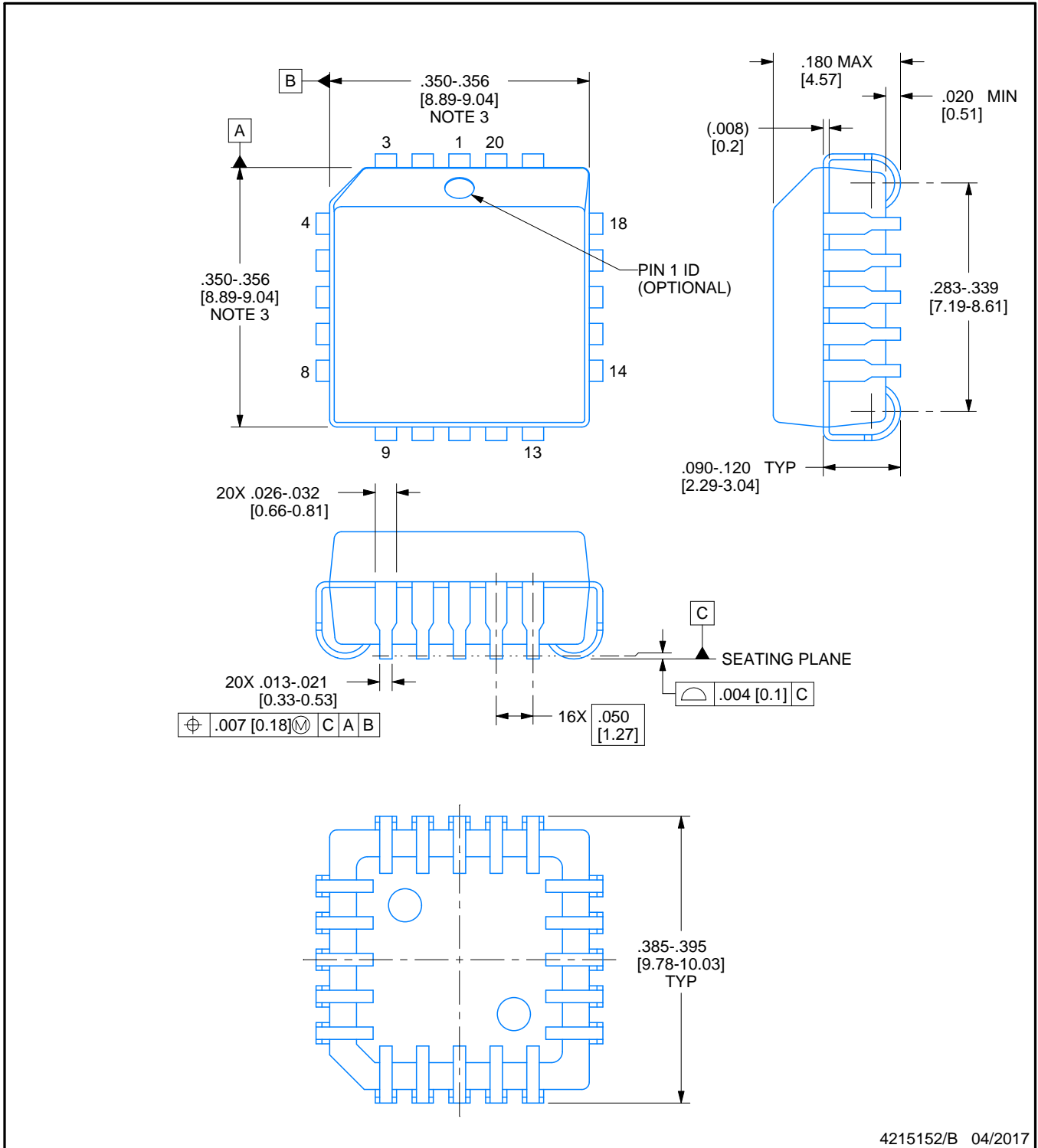

4215152/B 04/2017

### NOTES:

1. All linear dimensions are in inches. Any dimensions in brackets are in millimeters. Any dimensions in parenthesis are for reference only. Controlling dimensions are in inches. Dimensioning and tolerancing per ASME Y14.5M.
2. This drawing is subject to change without notice.
3. Dimension does not include mold protrusion. Maximum allowable mold protrusion .01 in [0.25 mm] per side.
4. Reference JEDEC registration MS-018.



# EXAMPLE BOARD LAYOUT

FN0020A

PLCC - 4.57 mm max height

PLASTIC CHIP CARRIER

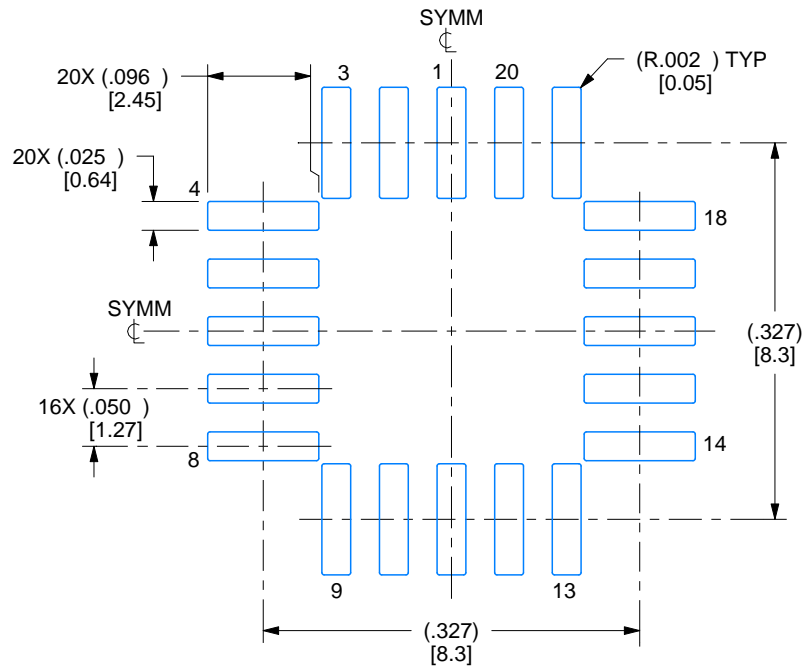

LAND PATTERN EXAMPLE  
EXPOSED METAL SHOWN  
SCALE:6X

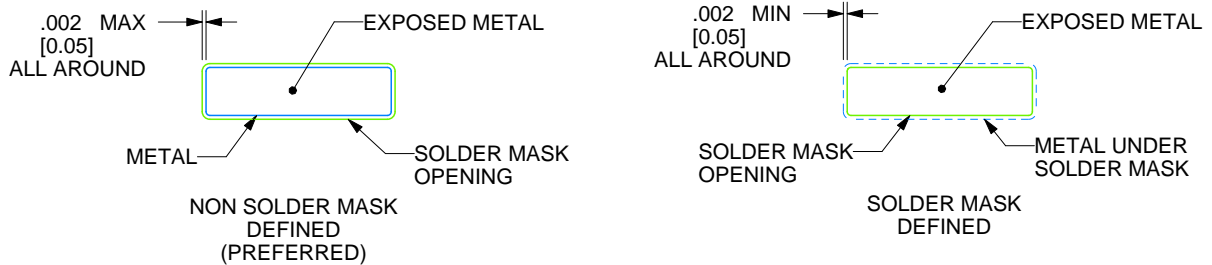

SOLDER MASK DETAILS

4215152/B 04/2017

NOTES: (continued)

- Publication IPC-7351 may have alternate designs.
- Solder mask tolerances between and around signal pads can vary based on board fabrication site.

# EXAMPLE STENCIL DESIGN

FN0020A

PLCC - 4.57 mm max height

PLASTIC CHIP CARRIER

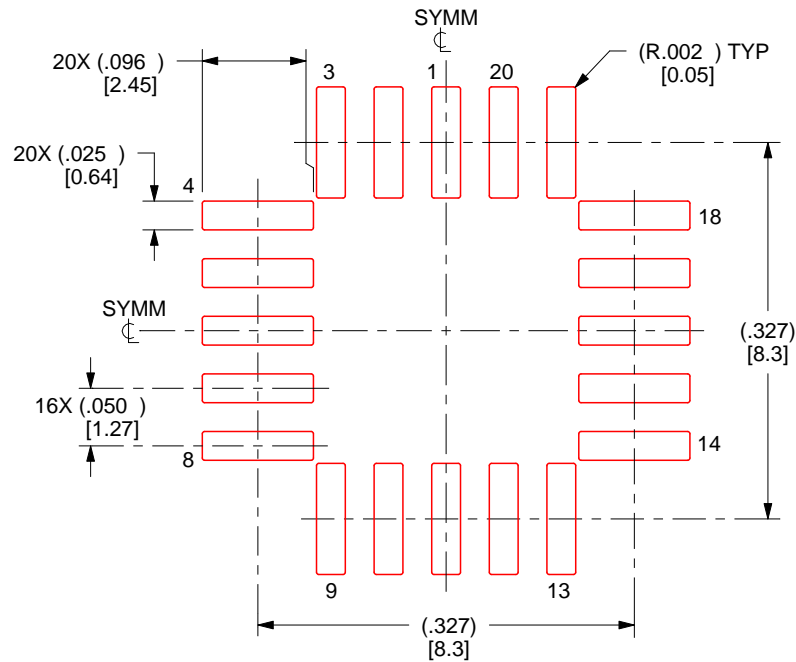

SOLDER PASTE EXAMPLE  
BASED ON 0.125 mm THICK STENCIL  
SCALE:6X

4215152/B 04/2017

NOTES: (continued)

7. Laser cutting apertures with trapezoidal walls and rounded corners may offer better paste release. IPC-7525 may have alternate design recommendations.
8. Board assembly site may have different recommendations for stencil design.

N (R-PDIP-T\*\*)

PLASTIC DUAL-IN-LINE PACKAGE

16 PINS SHOWN



4040049/E 12/2002

- NOTES:
- A. All linear dimensions are in inches (millimeters).
  - B. This drawing is subject to change without notice.
  - (C) Falls within JEDEC MS-001, except 18 and 20 pin minimum body length (Dim A).
  - (D) The 20 pin end lead shoulder width is a vendor option, either half or full width.

# DW0020A

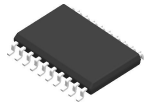

# PACKAGE OUTLINE

## SOIC - 2.65 mm max height

SOIC

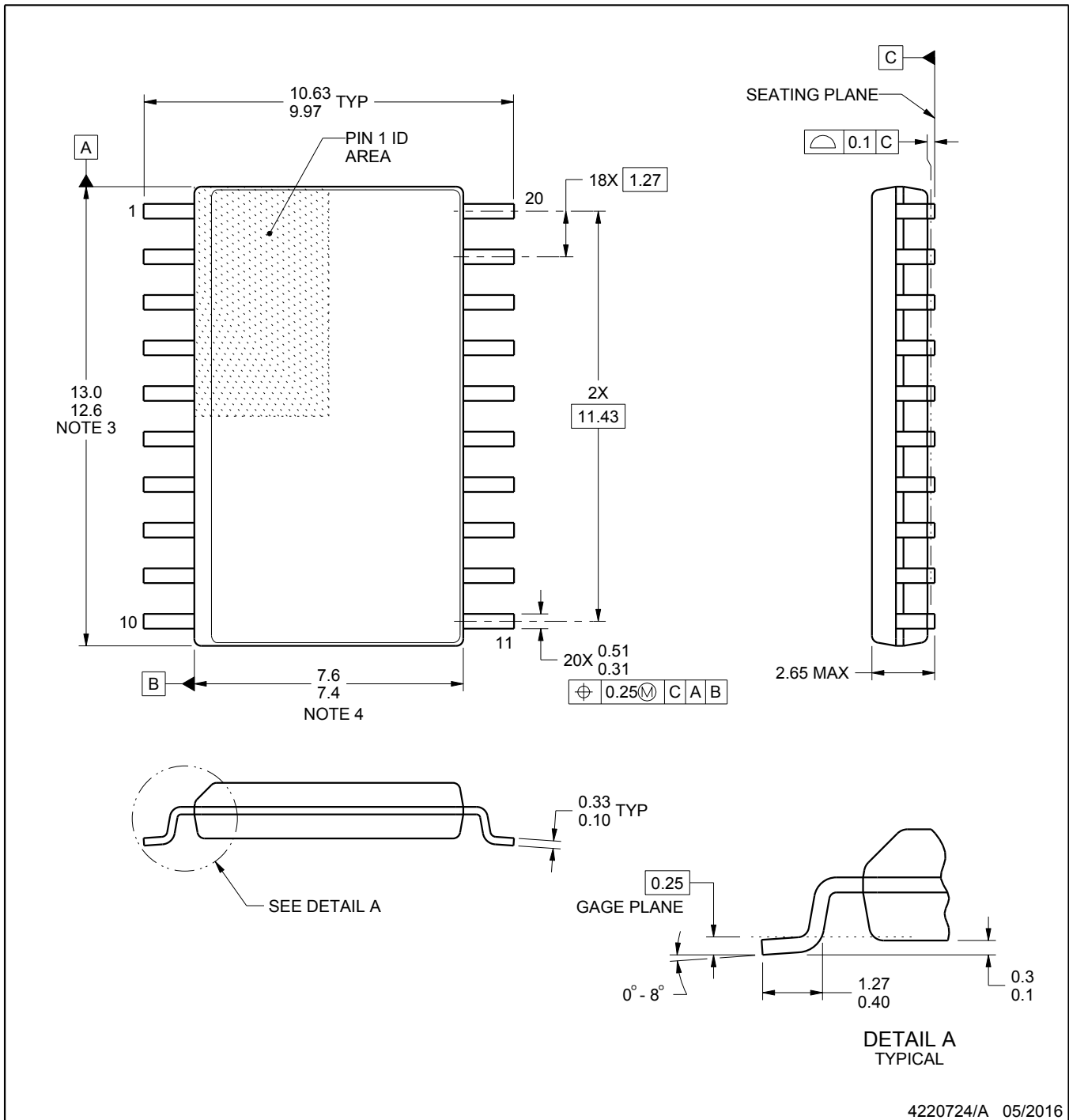

4220724/A 05/2016

**NOTES:**

1. All linear dimensions are in millimeters. Dimensions in parenthesis are for reference only. Dimensioning and tolerancing per ASME Y14.5M.
2. This drawing is subject to change without notice.
3. This dimension does not include mold flash, protrusions, or gate burrs. Mold flash, protrusions, or gate burrs shall not exceed 0.15 mm per side.
4. This dimension does not include interlead flash. Interlead flash shall not exceed 0.43 mm per side.
5. Reference JEDEC registration MS-013.

# EXAMPLE BOARD LAYOUT

DW0020A

SOIC - 2.65 mm max height

SOIC



LAND PATTERN EXAMPLE  
SCALE:6X



SOLDER MASK DETAILS

4220724/A 05/2016

NOTES: (continued)

- 6. Publication IPC-7351 may have alternate designs.
- 7. Solder mask tolerances between and around signal pads can vary based on board fabrication site.

# EXAMPLE STENCIL DESIGN

DW0020A

SOIC - 2.65 mm max height

SOIC



SOLDER PASTE EXAMPLE  
BASED ON 0.125 mm THICK STENCIL  
SCALE:6X

4220724/A 05/2016

NOTES: (continued)

8. Laser cutting apertures with trapezoidal walls and rounded corners may offer better paste release. IPC-7525 may have alternate design recommendations.
9. Board assembly site may have different recommendations for stencil design.

## IMPORTANT NOTICE

Texas Instruments Incorporated (TI) reserves the right to make corrections, enhancements, improvements and other changes to its semiconductor products and services per JESD46, latest issue, and to discontinue any product or service per JESD48, latest issue. Buyers should obtain the latest relevant information before placing orders and should verify that such information is current and complete.

TI's published terms of sale for semiconductor products (<http://www.ti.com/sc/docs/stdterms.htm>) apply to the sale of packaged integrated circuit products that TI has qualified and released to market. Additional terms may apply to the use or sale of other types of TI products and services.

Reproduction of significant portions of TI information in TI data sheets is permissible only if reproduction is without alteration and is accompanied by all associated warranties, conditions, limitations, and notices. TI is not responsible or liable for such reproduced documentation. Information of third parties may be subject to additional restrictions. Resale of TI products or services with statements different from or beyond the parameters stated by TI for that product or service voids all express and any implied warranties for the associated TI product or service and is an unfair and deceptive business practice. TI is not responsible or liable for any such statements.

Buyers and others who are developing systems that incorporate TI products (collectively, "Designers") understand and agree that Designers remain responsible for using their independent analysis, evaluation and judgment in designing their applications and that Designers have full and exclusive responsibility to assure the safety of Designers' applications and compliance of their applications (and of all TI products used in or for Designers' applications) with all applicable regulations, laws and other applicable requirements. Designer represents that, with respect to their applications, Designer has all the necessary expertise to create and implement safeguards that (1) anticipate dangerous consequences of failures, (2) monitor failures and their consequences, and (3) lessen the likelihood of failures that might cause harm and take appropriate actions. Designer agrees that prior to using or distributing any applications that include TI products, Designer will thoroughly test such applications and the functionality of such TI products as used in such applications.

TI's provision of technical, application or other design advice, quality characterization, reliability data or other services or information, including, but not limited to, reference designs and materials relating to evaluation modules, (collectively, "TI Resources") are intended to assist designers who are developing applications that incorporate TI products; by downloading, accessing or using TI Resources in any way, Designer (individually or, if Designer is acting on behalf of a company, Designer's company) agrees to use any particular TI Resource solely for this purpose and subject to the terms of this Notice.

TI's provision of TI Resources does not expand or otherwise alter TI's applicable published warranties or warranty disclaimers for TI products, and no additional obligations or liabilities arise from TI providing such TI Resources. TI reserves the right to make corrections, enhancements, improvements and other changes to its TI Resources. TI has not conducted any testing other than that specifically described in the published documentation for a particular TI Resource.

Designer is authorized to use, copy and modify any individual TI Resource only in connection with the development of applications that include the TI product(s) identified in such TI Resource. NO OTHER LICENSE, EXPRESS OR IMPLIED, BY ESTOPPEL OR OTHERWISE TO ANY OTHER TI INTELLECTUAL PROPERTY RIGHT, AND NO LICENSE TO ANY TECHNOLOGY OR INTELLECTUAL PROPERTY RIGHT OF TI OR ANY THIRD PARTY IS GRANTED HEREIN, including but not limited to any patent right, copyright, mask work right, or other intellectual property right relating to any combination, machine, or process in which TI products or services are used. Information regarding or referencing third-party products or services does not constitute a license to use such products or services, or a warranty or endorsement thereof. Use of TI Resources may require a license from a third party under the patents or other intellectual property of the third party, or a license from TI under the patents or other intellectual property of TI.

TI RESOURCES ARE PROVIDED "AS IS" AND WITH ALL FAULTS. TI DISCLAIMS ALL OTHER WARRANTIES OR REPRESENTATIONS, EXPRESS OR IMPLIED, REGARDING RESOURCES OR USE THEREOF, INCLUDING BUT NOT LIMITED TO ACCURACY OR COMPLETENESS, TITLE, ANY EPIDEMIC FAILURE WARRANTY AND ANY IMPLIED WARRANTIES OF MERCHANTABILITY, FITNESS FOR A PARTICULAR PURPOSE, AND NON-INFRINGEMENT OF ANY THIRD PARTY INTELLECTUAL PROPERTY RIGHTS. TI SHALL NOT BE LIABLE FOR AND SHALL NOT DEFEND OR INDEMNIFY DESIGNER AGAINST ANY CLAIM, INCLUDING BUT NOT LIMITED TO ANY INFRINGEMENT CLAIM THAT RELATES TO OR IS BASED ON ANY COMBINATION OF PRODUCTS EVEN IF DESCRIBED IN TI RESOURCES OR OTHERWISE. IN NO EVENT SHALL TI BE LIABLE FOR ANY ACTUAL, DIRECT, SPECIAL, COLLATERAL, INDIRECT, PUNITIVE, INCIDENTAL, CONSEQUENTIAL OR EXEMPLARY DAMAGES IN CONNECTION WITH OR ARISING OUT OF TI RESOURCES OR USE THEREOF, AND REGARDLESS OF WHETHER TI HAS BEEN ADVISED OF THE POSSIBILITY OF SUCH DAMAGES.

Unless TI has explicitly designated an individual product as meeting the requirements of a particular industry standard (e.g., ISO/TS 16949 and ISO 26262), TI is not responsible for any failure to meet such industry standard requirements.

Where TI specifically promotes products as facilitating functional safety or as compliant with industry functional safety standards, such products are intended to help enable customers to design and create their own applications that meet applicable functional safety standards and requirements. Using products in an application does not by itself establish any safety features in the application. Designers must ensure compliance with safety-related requirements and standards applicable to their applications. Designer may not use any TI products in life-critical medical equipment unless authorized officers of the parties have executed a special contract specifically governing such use. Life-critical medical equipment is medical equipment where failure of such equipment would cause serious bodily injury or death (e.g., life support, pacemakers, defibrillators, heart pumps, neurostimulators, and implantables). Such equipment includes, without limitation, all medical devices identified by the U.S. Food and Drug Administration as Class III devices and equivalent classifications outside the U.S.

TI may expressly designate certain products as completing a particular qualification (e.g., Q100, Military Grade, or Enhanced Product). Designers agree that it has the necessary expertise to select the product with the appropriate qualification designation for their applications and that proper product selection is at Designers' own risk. Designers are solely responsible for compliance with all legal and regulatory requirements in connection with such selection.

Designer will fully indemnify TI and its representatives against any damages, costs, losses, and/or liabilities arising out of Designer's non-compliance with the terms and provisions of this Notice.