



**UL**<sup>®</sup>  
US  
E494324

## APPLICATIONS

Street and Roadway Lighting  
Photo controls  
Parking Lot Lighting

# ANSI C136.41-2013 Dimming Receptacles A41-3/5/7

## 1. INTRODUCTION

This specification covers the requirements for application of ANSI C136.41-200X Dimming Receptacles typically used for roadway and area lighting. All contacts are pre-installed into the receptacle housing and pre-crimped with 305 mm (12.0 in.) lead-wire, with 14 AWG stranded wire used on the three line voltage AC circuits and 18 AWG wire used on the four signal dimming control voltage DC circuits. Receptacle assemblies are available with -40-70°C. Receptacle assemblies are also available with either 2 or 4 dimming control pad-style contacts.



A41-3/5/7 SPEC-V3 11/2017



### NOTE

All numerical values are in metric units [with U.S. customary units in brackets]. Dimensions are in millimeters. Unless otherwise specified, dimensions have a tolerance of  $\pm 0.13$  mm and angles have a tolerance of  $\pm 2^\circ$ . Figures and illustrations are for identification only and are not drawn to scale.

Please use the terminology provided in this specification to facilitate inquiries for information. Basic terms and features of this product are provided in Figure 1.

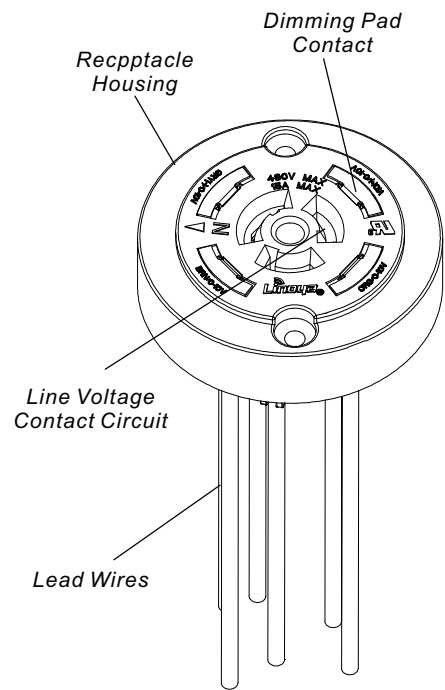
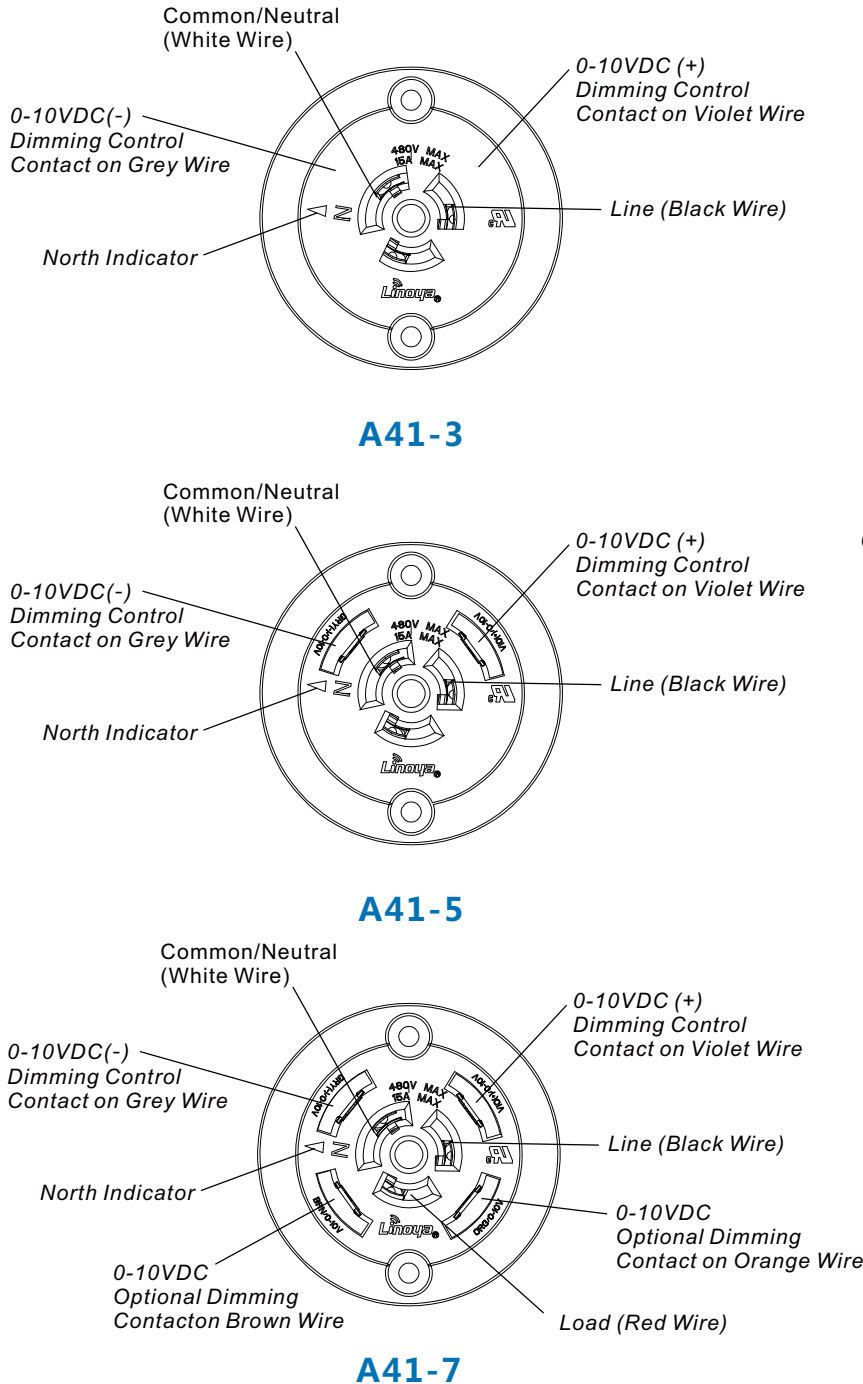

**Figure 1**



## 2. REFERENCE MATERIAL

### 2.1. Revision Summary

Initial release of application specification

### 2.2. Customer Assistance

Reference Product Base Part Number A41-3/5/7 are representative of the ANSI C136.41-200X Dimming Receptacles. Use of these numbers will identify the product line and help you to obtain product and tooling information. Such information can be obtained through a local linoya Representative, by visiting our website at [www.linoya.com](http://www.linoya.com), or by calling PRODUCT INFORMATION or the TOOLING ASSISTANCE CENTER at the numbers at the bottom of page.

### 2.3. Drawings

Customer Drawings for product part numbers are available from the service network. If there is a conflict between the information contained in the Customer Drawings and this specification or with any other technical documentation supplied, the information contained in the Customer Drawings takes priority.

### 2.4. Specifications

Product Specification A41-3/5/7 provides product performance and test information for the ANSI C136.41-2013 Dimming Receptacle.

## 3. REQUIREMENTS

### 3.1. Safety

Perform all wiring of receptacle with power turned OFF.

### 3.2. Limitations

The connectors are designed to operate in a temperature range of -40° to 85°C [-40° to 185°F].

### 3.3. Material

The housing is made of UL 94V-0 rated thermoplastic. The line voltage contacts are made of phosphorous bronze plated overall with tin. Dimming pad contacts are made of brass with gold plating in contact pad area, tin plated in wire crimp area with nickel under-plate on entire contact.

### 3.4. Storage

#### A. Ultraviolet Light

Prolonged exposure to ultraviolet light may deteriorate the chemical composition used in the product material.

#### B. Shelf Life

The product should remain in the shipping containers until ready for use to prevent deformation to components. The product should be used on a first in, first out basis to avoid storage contamination that could adversely affect performance.

#### C. Chemical Exposure

Do not store product near any chemical listed below as they may cause stress corrosion cracking in the material.

Alkalies	Ammonia	Citrates	Phosphates	Citrates	Sulfur Compounds
Amines	Carbonates	Nitrites	Sulfur	Nitrites	Tartrates



### 3.5. Handling

The receptacle assembly is supplied with a mating face cap to provide protection during shipping. Dimming contact pads are lubricated with an electrical contact lubricant; therefore after removal of the protective cap, avoid contact with the dimming contact pads which could remove the electrical contact lubricant.

### 3.6. Receptacle Mounting

#### A. Mounting

A flat surface shall be provided on luminaire housing to mount receptacle assembly. To provide water-tight mounting, it is highly recommended that a gasket (not provided with receptacle assembly) be used to seal surfaces between receptacle assembly and luminaire housing. The receptacle housing has two mounting holes which accept #8 size flat-head recessed screws. Screws of the appropriate length and type must be determined by the luminaire manufacturer. Depending on the type of gasket and mounting screws used, it is the responsibility of the installer to determine the mounting screw torque to ensure a rain-tight gasketed seal between the receptacle and luminaire housing. See Figure 2.

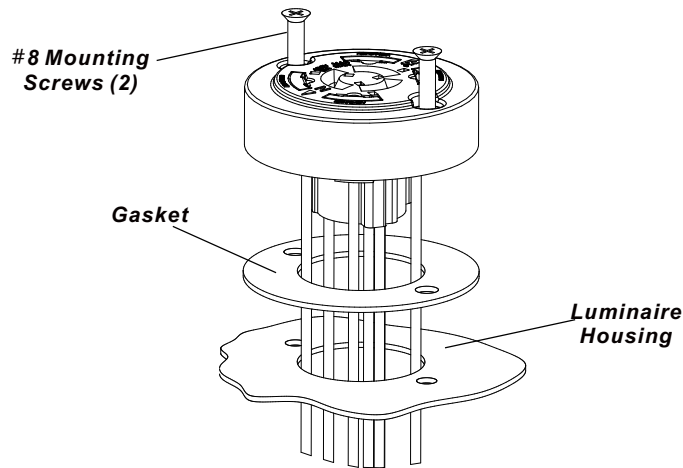

Figure 2

#### B. Mounting Hole Pattern

The recommended mounting hole pattern is shown in Figure 3.

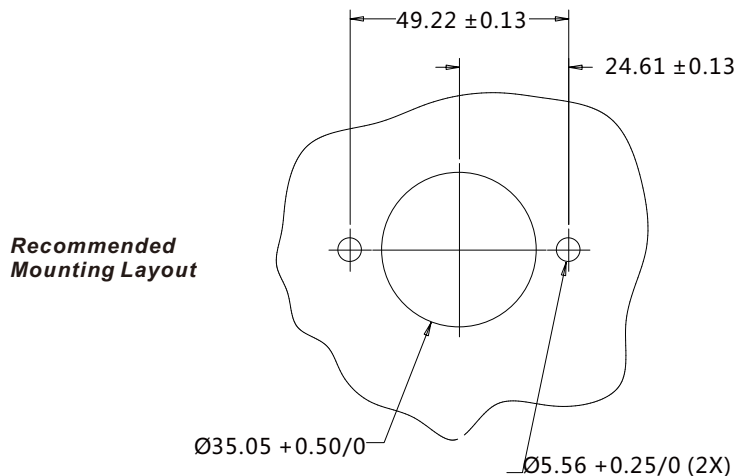

Figure 3

### C. Mounting Location and Orientation

Locate the receptacle where artificial light cannot fall on the mating photocell causing it to turn off or cycle (on and off) at night. If possible, orient the receptacle so the North indicator points North.

### D. Workmanship

The housing must not be damaged in any way. There shall be no nicked wire insulation.

## 3.7. Wire Connections and Diagram

### A. Wire Connections

The receptacle wires must be appropriately spliced with the correct line voltage power or dimming signal source. When splicing lead wires with crimp-style splices, wire nuts, etc., ensure the proper size splicing connector per the manufacturers's recommendation is being used.



#### DANGER

Extreme caution must be taken to ensure that power is OFF prior to disconnecting or connecting any wires to prevent electrical shock.



#### NOTE

All wire connections must be electrically insulated.

### B. Wiring Diagram

The receptacle wires must be appropriately spliced with the correct line voltage power or dimming signal source. Refer to the wiring diagram example shown in Figure 4. Wiring diagram shown is for general information only. Luminaire manufacturer must determine wiring diagram based upon their ballast/driver with dimming control components.

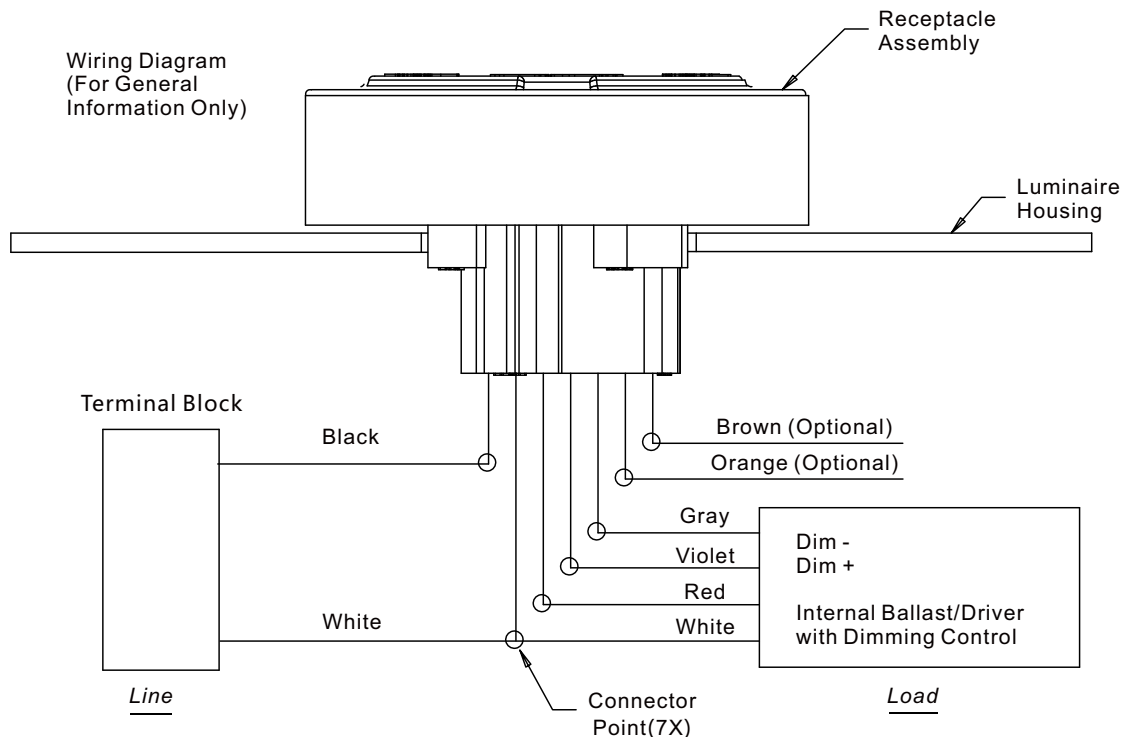

Figure 4

**CA** US  
**E494324**

### 3.8. Strain Relief

It is recommended that a means be provided to support the wire bundle extending away from the receptacle assembly to prevent inadvertent application of high force to the wire bundle from transmitting into the wire/connector interface. The suggested strain relief method is to use a cable tie and anchor mounted inside the luminaire.

### 3.9. Mating and Un-mating Photocell to Receptacle

Align photocell blades with receptacle power contact circuits. Note that the neutral photocell blade is larger than the line and load blades, providing mating polarization. After properly aligning the blades to the receptacle power contact circuits, push downward until the photocell is bottomed on the receptacle's mating surface, slightly compressing gasket of the photocell. Then complete mating by twisting the photocell in a clockwise direction. The photocell will lock into position. To un-mate, reverse the aforementioned mating process. Reference Figure 5.

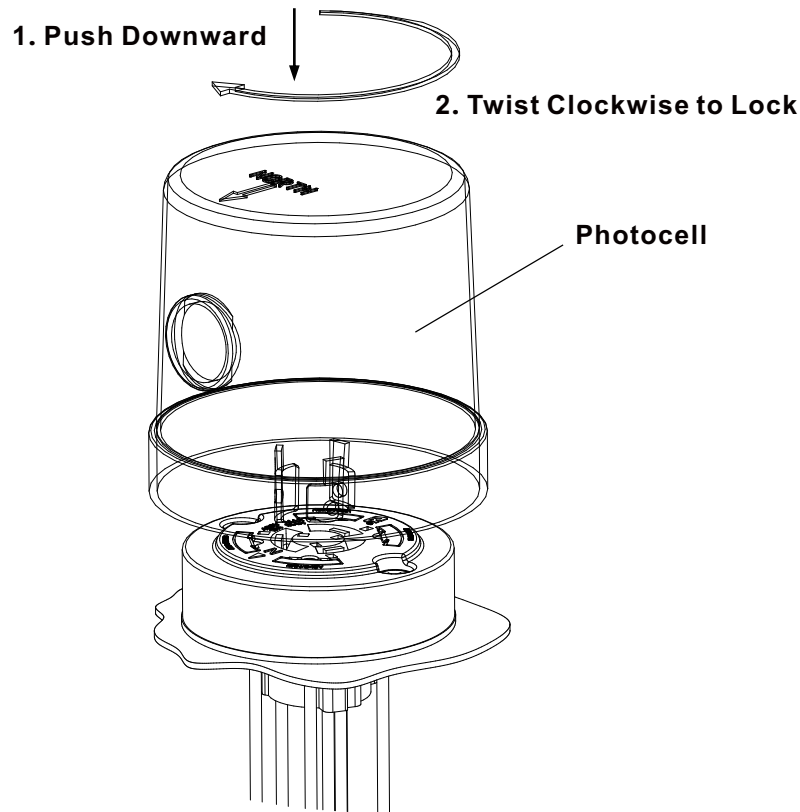

Figure 5

### 3.10. Replacement and Repair

The contacts and housings are not repairable. DO NOT use an assembly with damaged or defective contacts and/or housings. If damaged, replace the receptacle assembly with a new one.

## 4. QUALIFICATIONS

ANSI C136.41-2013 Dimming Receptacles are Component Recognized by Underwriters Laboratories, Inc. in File E66375, Volume 5, and have been Investigated to CSA International by UL.

## 5. TOOLING

No special tooling is require for the installation of this product line.



### 6. VISUAL AID

The illustration below shows a typical application of ANSI C136.41-200X Dimming Receptacles. This illustration should be used by production personnel to ensure a correctly applied product. Applications which DO NOT appear correct should be inspected using the information in the preceding pages of this specification and in the instructional material shipped with the product or tooling.

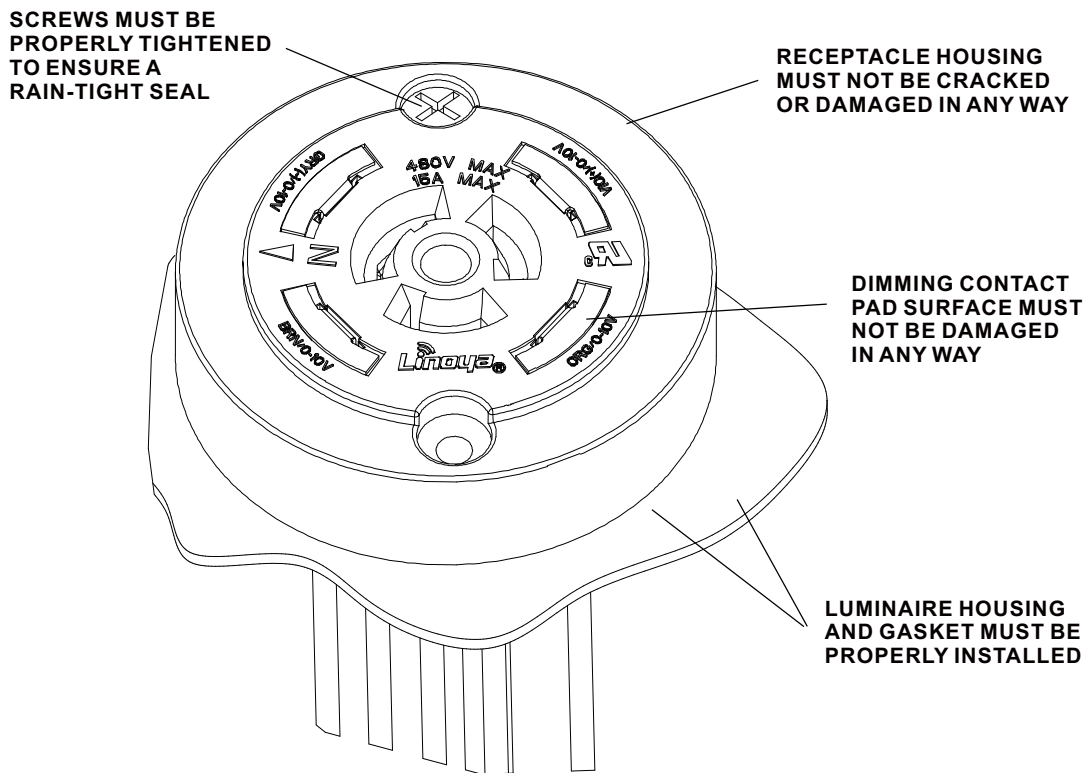

**FIGURE 6. VISUAL AID**



序号	修改内容	修改	日期	版次

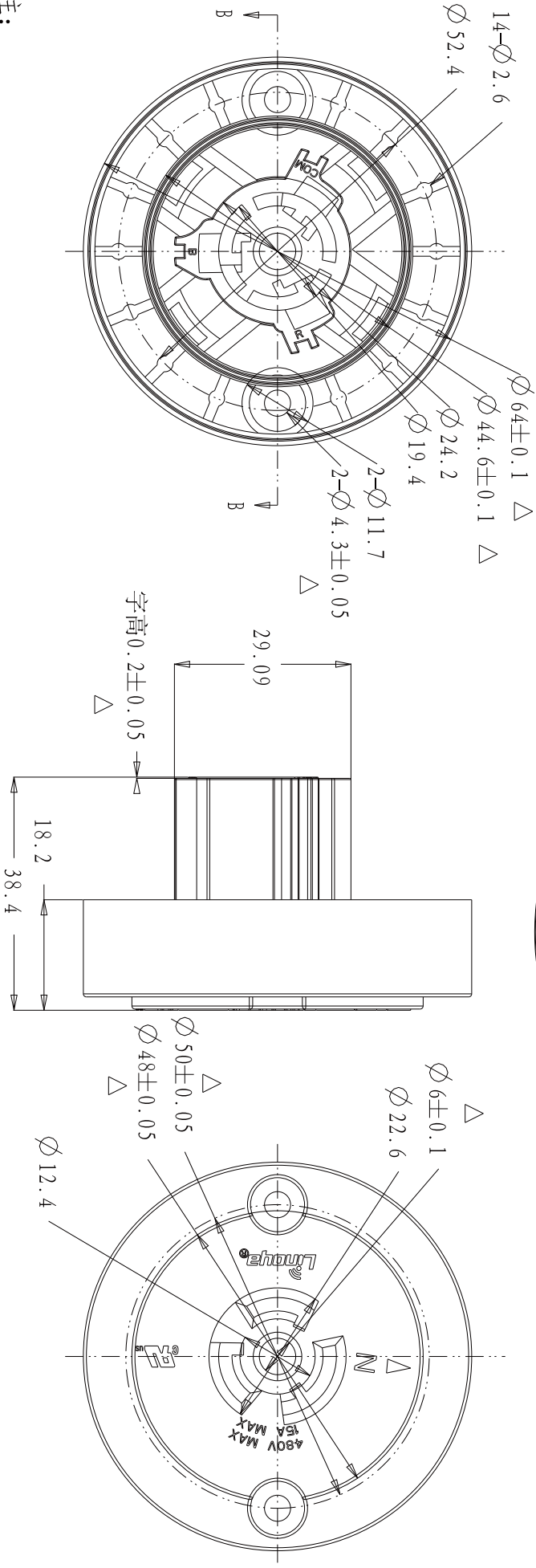
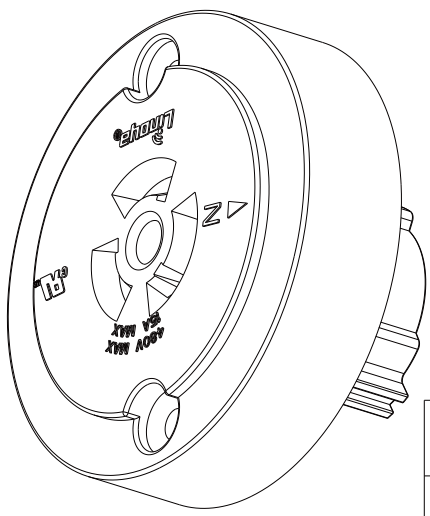
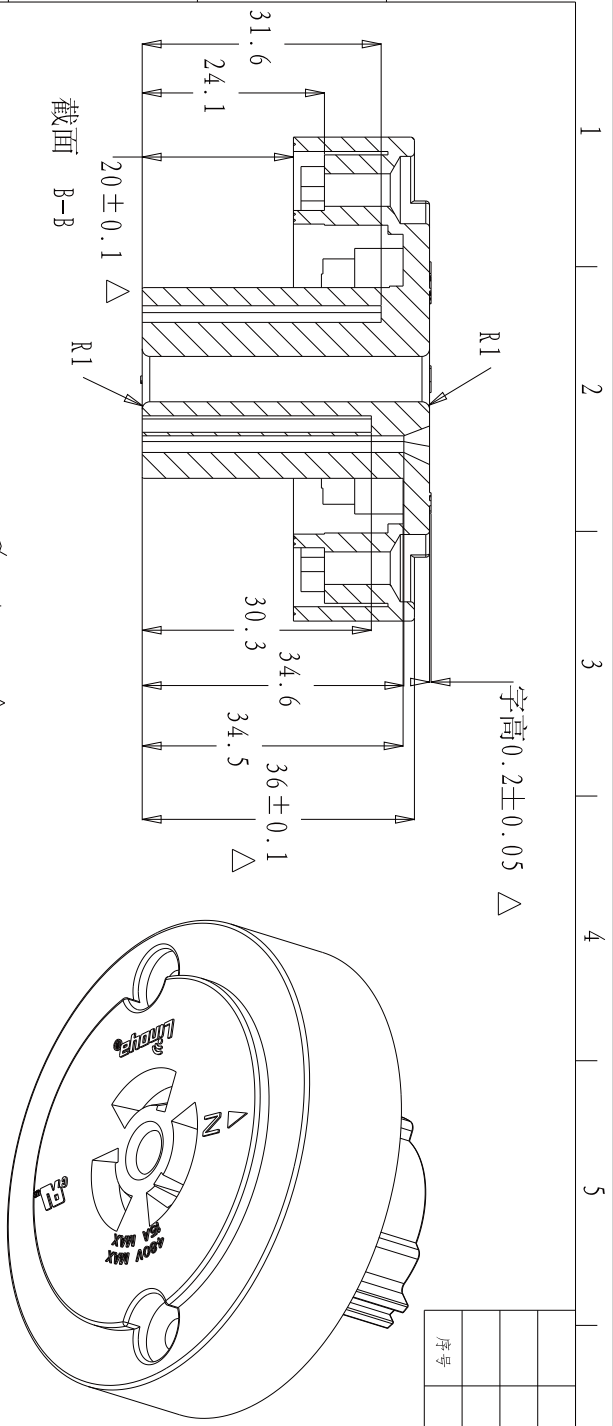

备注:

- 1、材质: MPP0 1000-GF30V 灰色RR0235 GB/T2408-V0阻燃等级;
- 2、产品尺寸不能按3D图缩水、纸、变形等塑胶不良现象;
- 3、未注尺寸与装配件颜色、三角形符号尺寸为重点尺寸;
- 4、此产品与模要清晰, 容易辨认;
- 5、

表面处理:		Linoya 领亚电子股份有限公司 Linoya Electronics Technology Co., Ltd			
页码: 1/1	材质: MPP0	制图: Aaron	2017.05.01	版本: 视角	A1
重量:	公差: X±0.1 XX±0.05 X±0.5 XXX±0.02	审核: 核准	比例: 1:1	品名: 下盖	A41-3
模具编号:				单位: mm	



序号	修改内容	修改	日期	版次

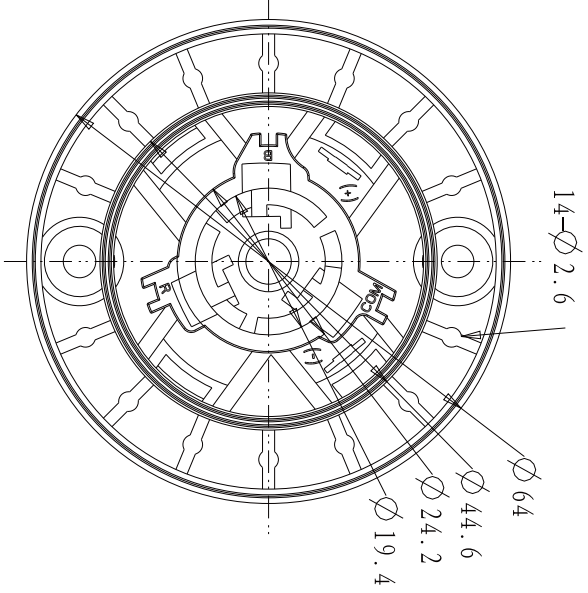
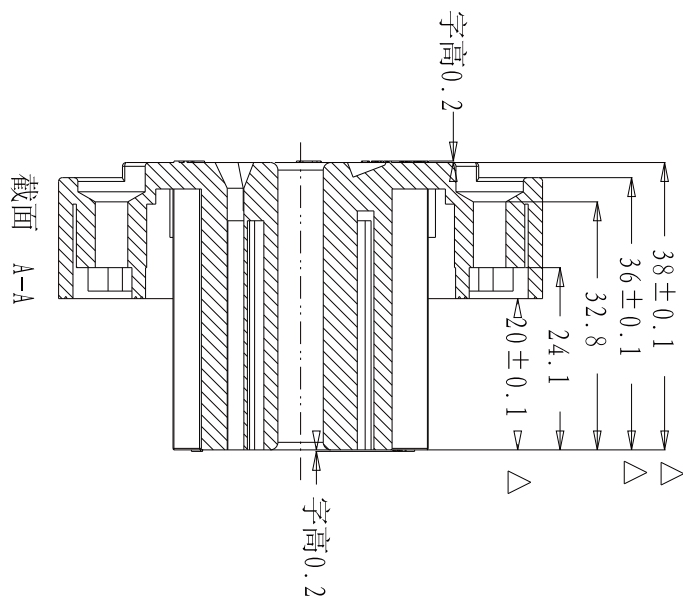
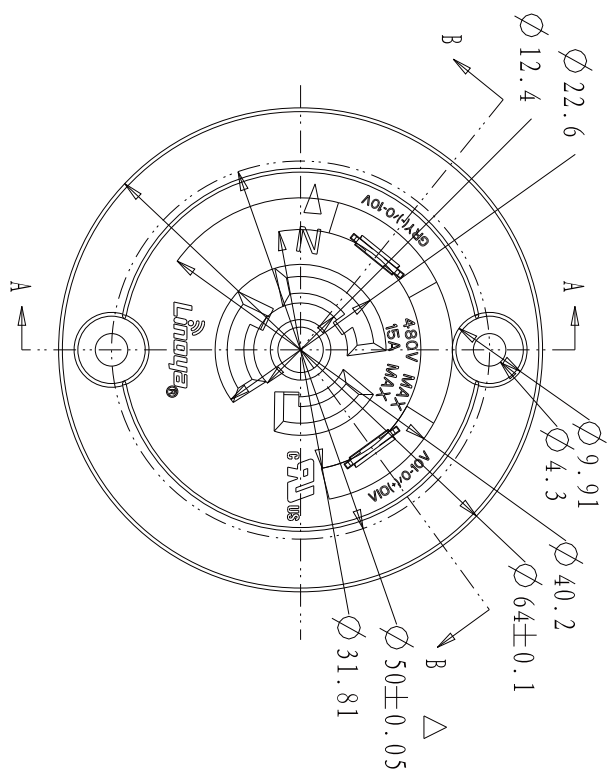
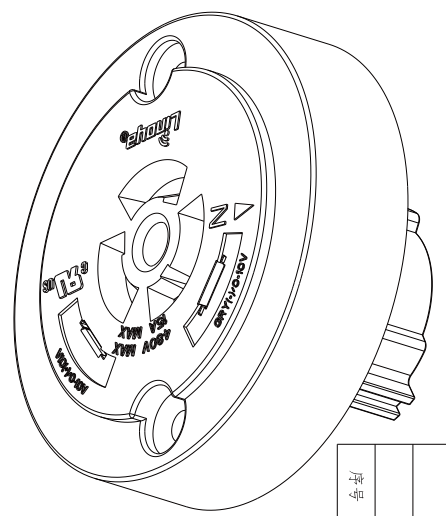
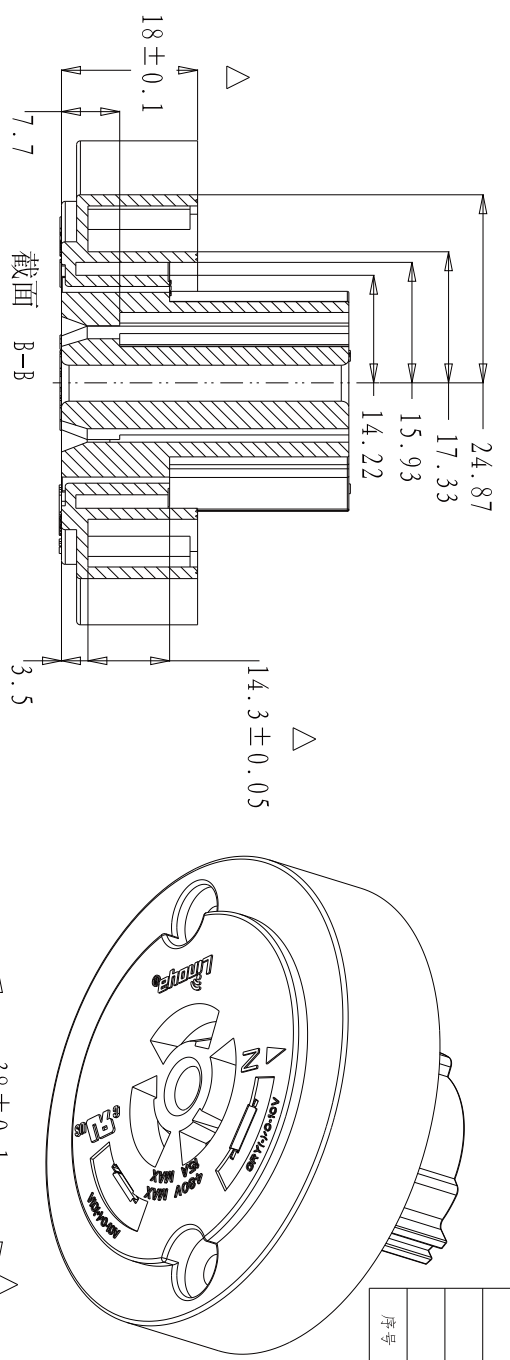

备注

- 1、材质：MPP0 1000-GF30V 灰色 RR0235 GB/T2408-V0阻燃等级；
- 2、产品尺寸不能有缩水、变形等现象；
- 3、未注尺寸按3D图纸，有三角形符号尺寸为重点尺寸；
- 4、此产品与模要清晰可见；
- 5、产品字与模要清晰可见；

表面处理：		Linoya		领亚电子股份有限公司		Linoya Electronics Technology Co., Ltd	
页码：1/1	材质：MPP0	制图	Aaron	2017.05.01	版本	视角	A1
重量：	公差：X±0.1 XX±0.05 X°±0.5° XXX±0.02	审核			审核	图纸编号	A41-5
模具编号：		比例	FREE	品名	上盖	单位	mm

序号	修改内容	修改	日期	版次

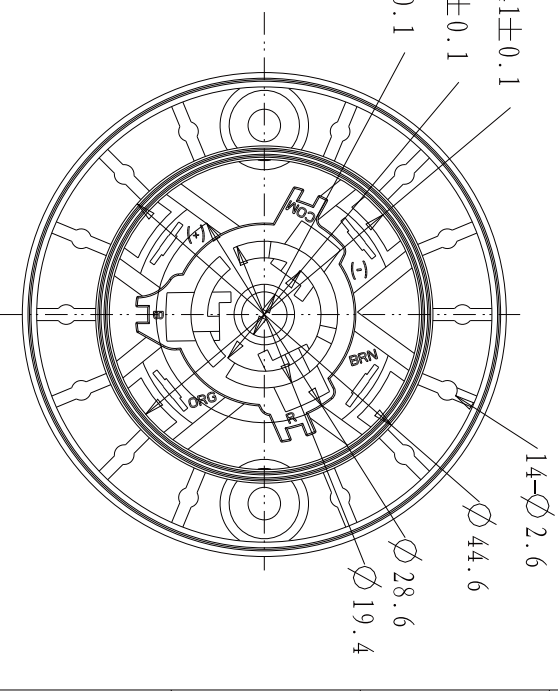
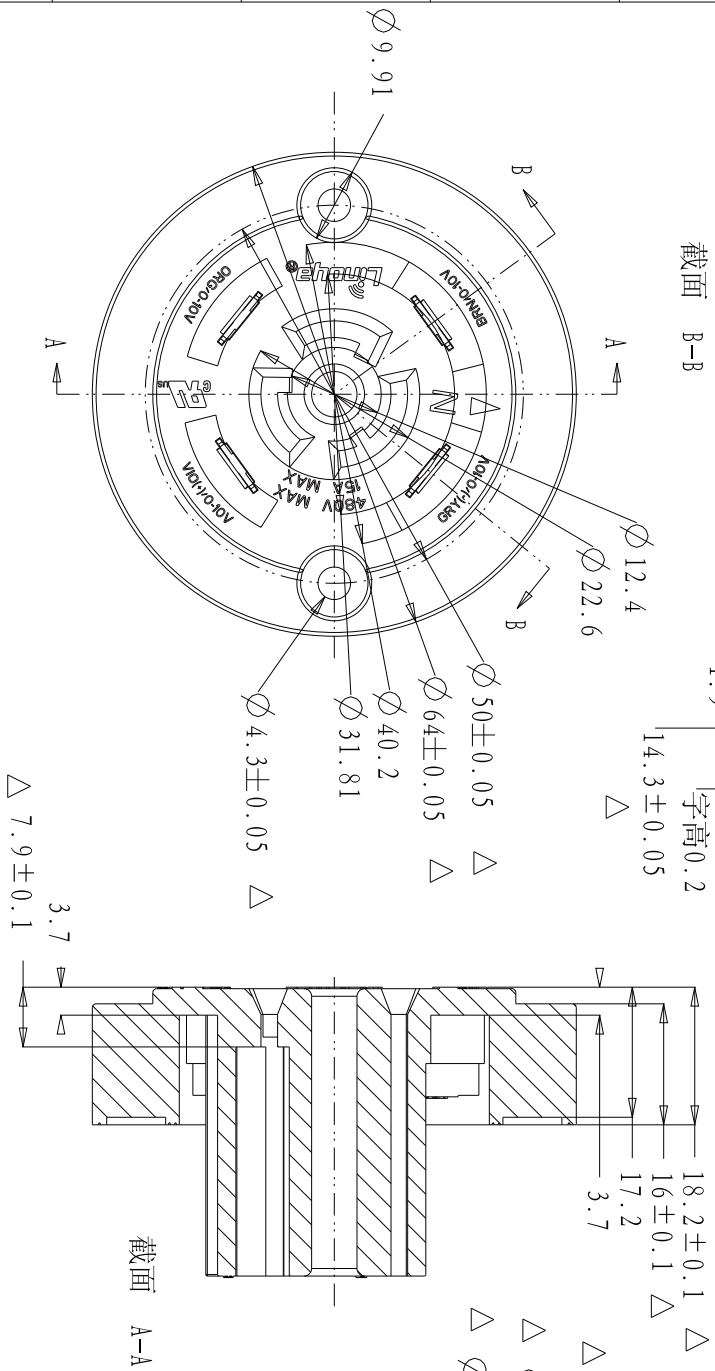
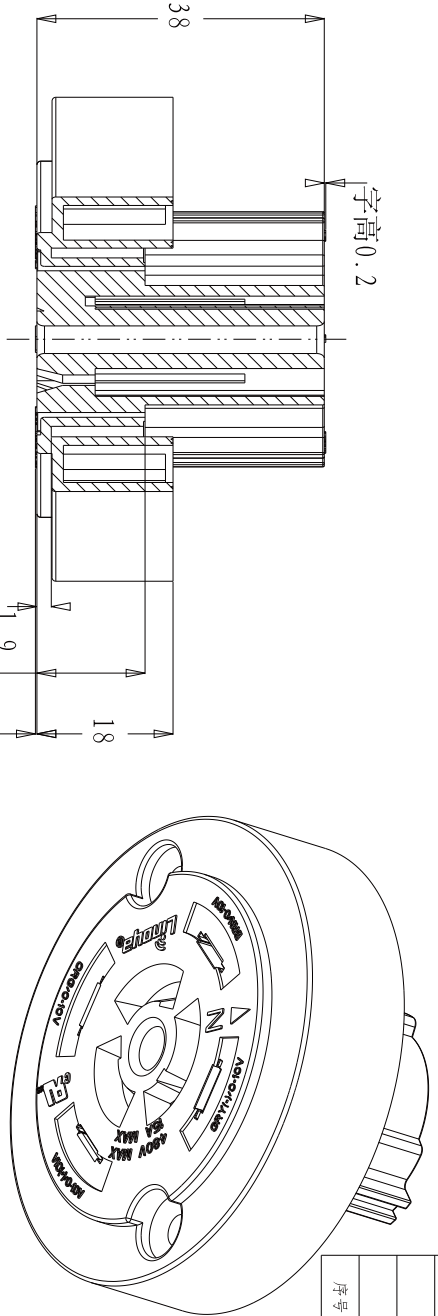

备注:

- 1、材质: MPP0 1000-GF30V 灰色RR0235 GB/T2408-V0阻燃等级;
- 2、产品不能有缩水、变形等塑胶不良现象;
- 3、未注尺寸按3D图纸,有三角形符号尺寸为重点尺寸;
- 4、此产品与装配件颜色无明显色差;

表面处理:	Linoya 领亚电子股份有限公司 Linoya Electronics Technology Co., Ltd			
页码: 1/1	材质: MPP0	制图: Aaron	2017.05.01	版本: A1
重量:	公差: X ±0.1 XX ±0.05 X° ±0.5° XXX ±0.02	审核: 核准	比例: FREE	品名: 下盖
模具编号:				图纸编号: A41-7
				单位: mm