



K2 Draw Latch

Rotary · Medium · Stylized wing

- Lift and Turn operation
- Consistent pull-up

Material and Finish

Stainless steel or steel, black powder coated

Performance Details

Steel:

Max. working load: 1230 N (275 lbf)

Stainless steel:

Max. working load: 845 N (190 lbf)

Operating temperature range:
-40°C (-40°F) to 80°C (175°F)

Installation Notes

Install assembly with $\varnothing 4$ (.157) rivets or M4 (No. 8) screws (not supplied)

Notes

Spring loaded:

Ideal for applications where shock and vibration occur. Compensates up to 1.7 (.07) for mounting hole irregularities, panel variations and gasket set. Also provides an additional allowance of 2.3 (.09) deflection when loaded.

Spring Loaded

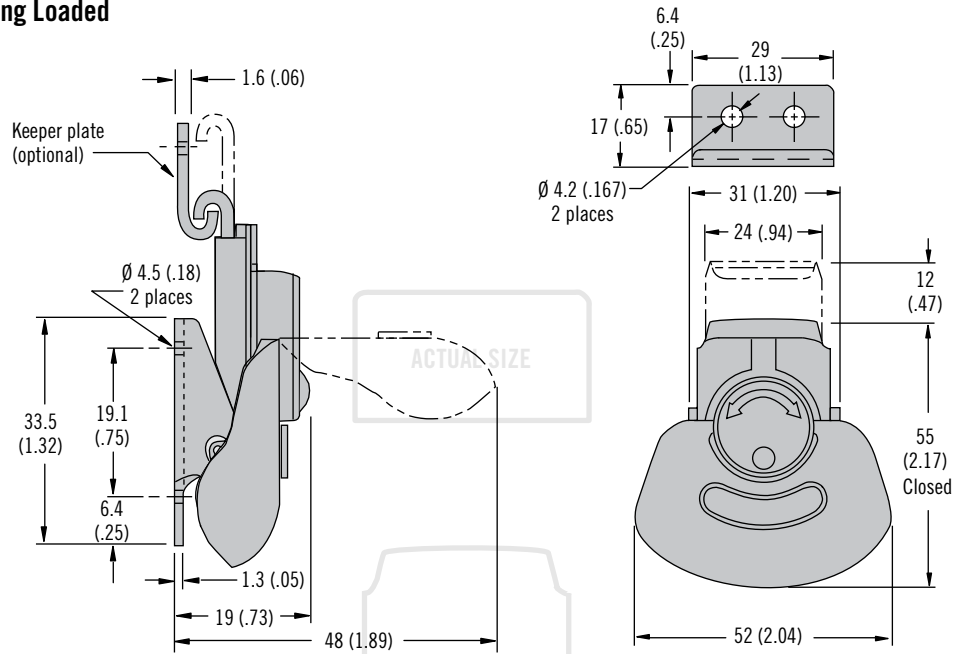

Fixed

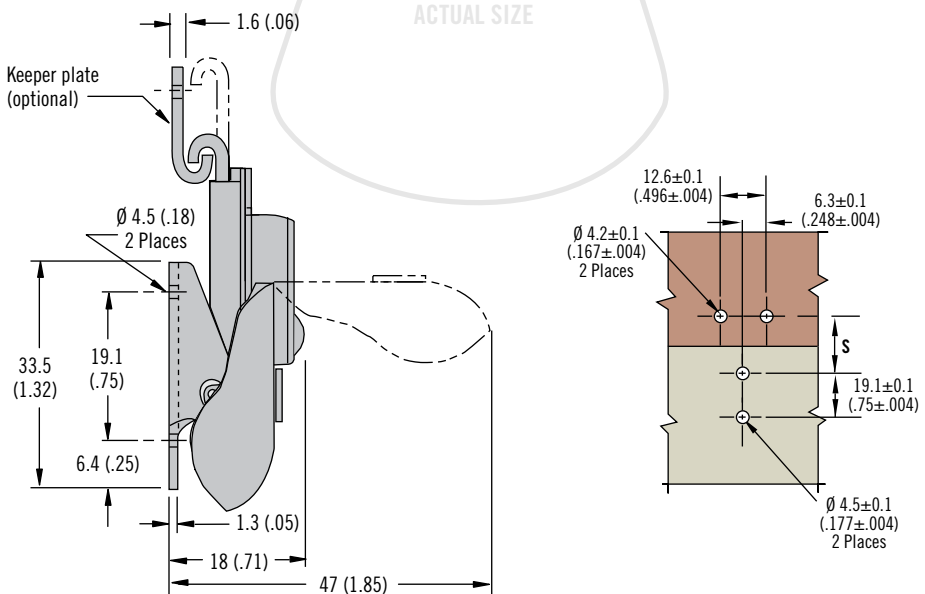

Part Number

See table

Order latch and keeper separately

Latch	Part Number			S
	Style	Steel, Black Powder Coated	Stainless Steel	
	Spring loaded	K2-3005-89	K2-3005-51	
Fixed	K2-3001-89	K2-3001-51	32 ± 0.2 (1.25 ± .01)	
Keeper plate		K4-2338-89	K4-2338-51	

Dimensions in millimeters (inch) unless otherwise stated



www.southco.com/K2

K3 Draw Latch

Rotary · Small



Hinge Lock

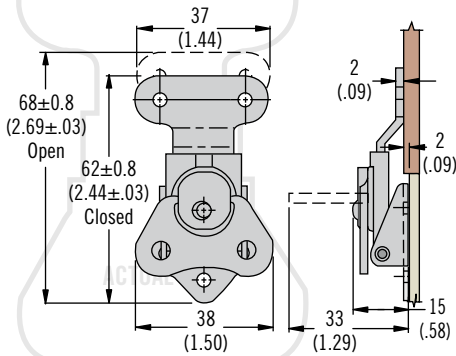

Low Profile

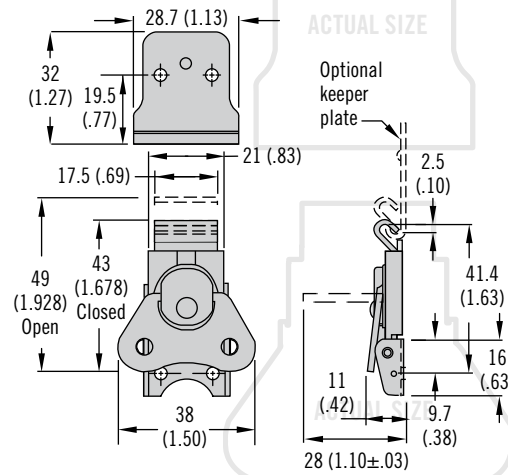

Long Slide

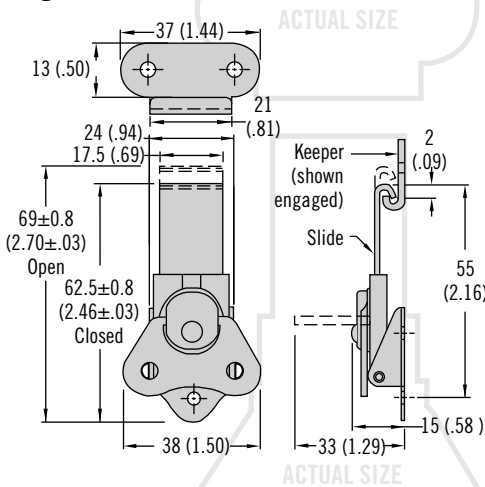

Short Anchor Plate

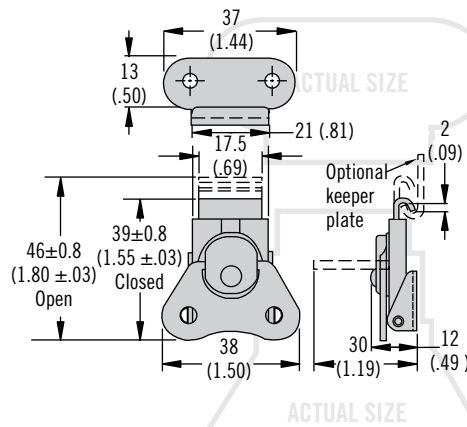

Hinge Lock

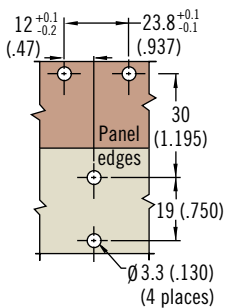

Long Slide

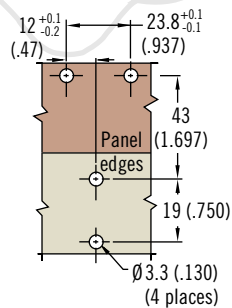

Low Profile

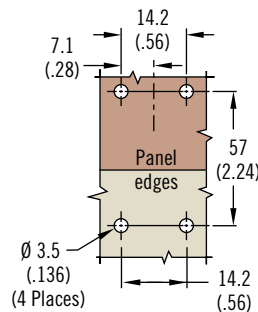

Short Anchor Plate

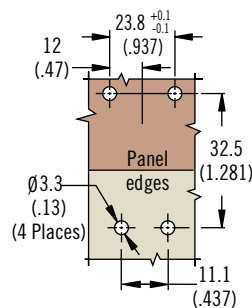

• Adjustable grip

Material and Finish

Stainless steel or steel, zinc plated

Installation Notes

Install assembly with Ø 3 (.125) rivets or M3 (No. 4) screws (not supplied)

Notes

Hinge lock style has an integrally attached keeper

Material	Latch Part Number				Keeper Part Number	
	Hinge Lock	Long Slide	Low Profile	Short Anchor Plate	Keeper	Low Profile Keeper
Steel	K3-1746-07	K3-2347-07	K3-2694-07	K3-1660-07	K3-0334-07	K3-2696-07
Stainless Steel	~	K3-2347-52	~	K3-1660-52	K3-0334-52	~

Part Number

See table

Order latch and keeper separately



K3 Draw Latch

Rotary · Small

- Lift and Turn operation
- Consistent pull-up

Material and Finish

Stainless steel or steel, zinc plated

Installation Notes

Install assembly with $\varnothing 3$ (.125) rivets or M3 (No. 4) screws (not supplied)

Notes

Spring loaded:

Ideal for applications where shock and vibration occur. Compensates up to 4 (.156) for mounting hole irregularities, panel variations and gasket set.

Riveted

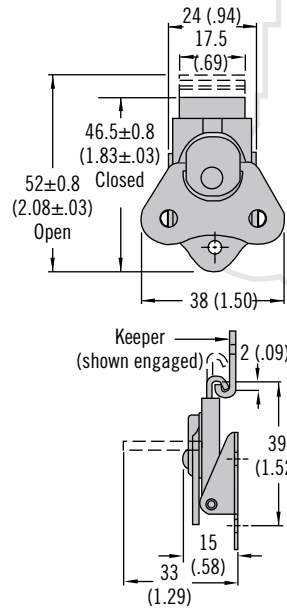

Spring Loaded

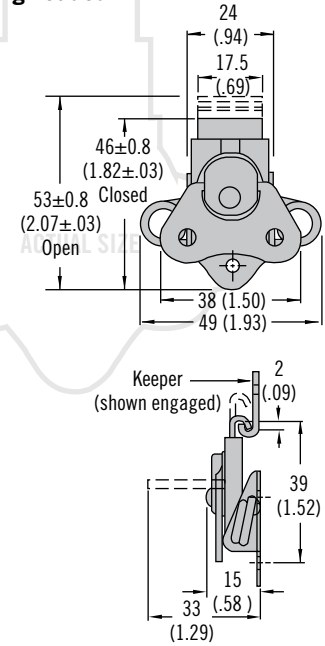

Keeper

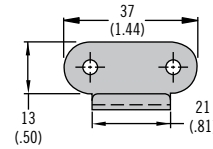

Padlockable

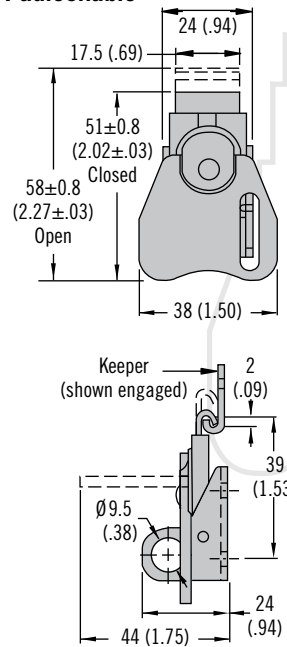

Kick-Out Spring

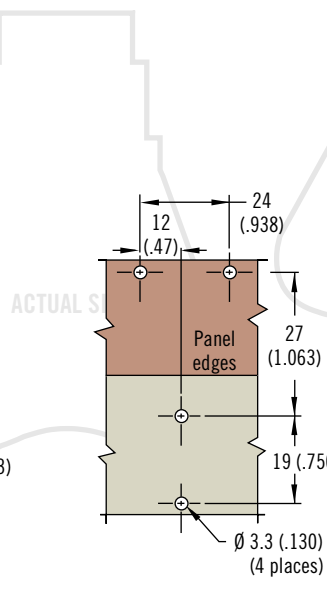
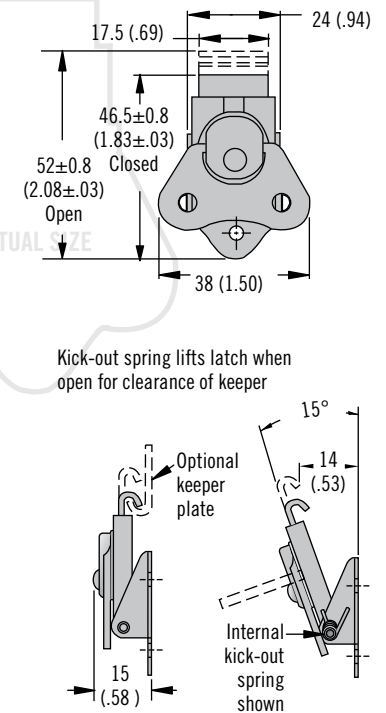

Part Number

See table

Order latch and keeper separately

Material	Part Number				
	Riveted	Spring Loaded	Padlockable	Kick-Out Spring	Keeper
Steel	K3-1625-07	K3-1735-07	K3-2403-07	K3-1887-07	K3-0334-07
Stainless Steel	K3-1625-52	K3-1735-52	K3-2403-52	K3-1887-52	K3-0334-52

Dimensions in millimeters (inch) unless otherwise stated

K4 Draw Latch

Rotary · Medium



Riveted

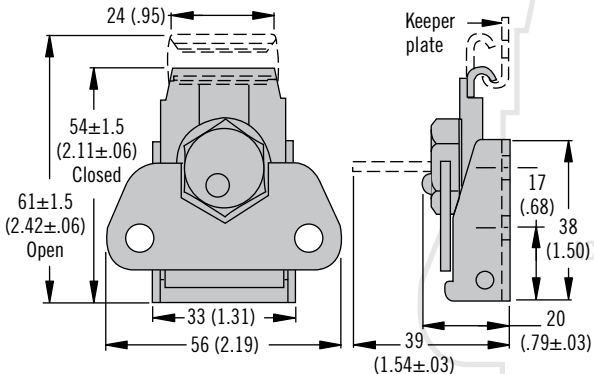

Keeper

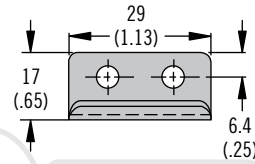

Spring Loaded

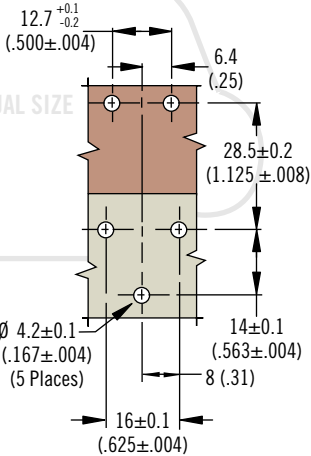
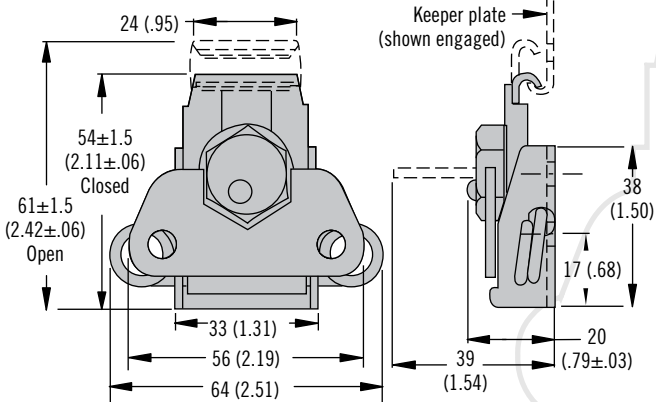

Key Lockable

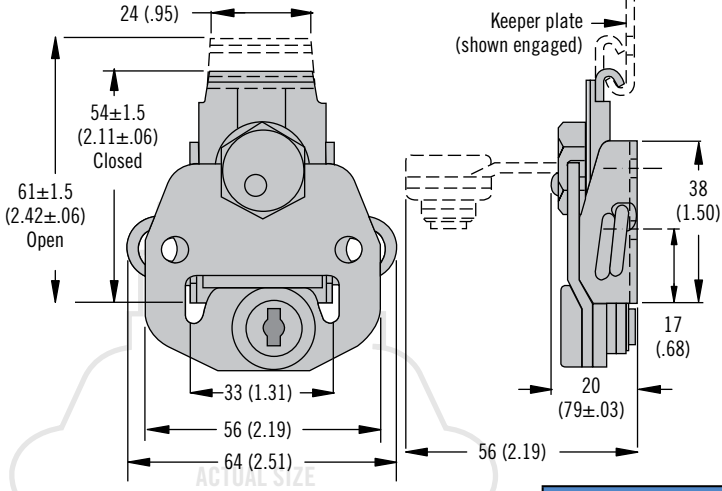

Type	Part Number	
	Latch	Keeper
Riveted	K4-2714-07	K4-2338-07
Spring loaded	K4-2359-07	
Key lockable	K4-2833-07	

- Lift and Turn operation
- Consistent pull-up

Material and Finish

Steel, zinc plated

Installation Notes

Install assembly with Ø 4 (.157) rivets or M4 (No. 8) screws (not supplied)

Notes

Spring loaded:
Ideal for applications where shock and vibration occur. Compensates up to 4 (.156) for mounting hole irregularities, panel variations and gasket set.





K5 Draw Latch

Rotary · Large

- Lift and Turn operation
- Consistent pull-up

Material and Finish

Stainless steel or steel, zinc plated

Installation Notes

Install assembly with $\varnothing 5$ (3/16) rivets or M5 (No. 10) screws (not supplied)

Notes

Spring loaded and low profile:
Ideal for applications where shock and vibration occur. Compensates up to 4 (.16) for mounting hole irregularities, panel variations and gasket set.

Riveted (hex cam shown)

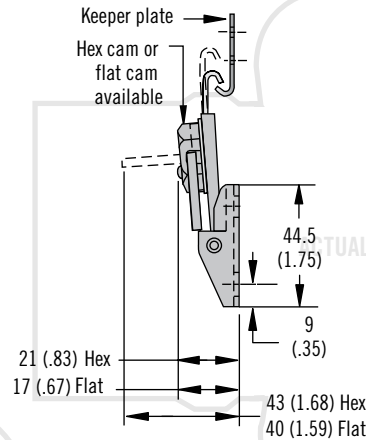
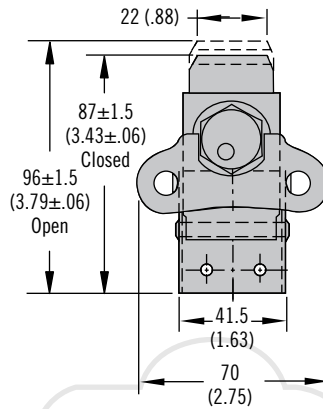

Low Profile (flat cam shown)

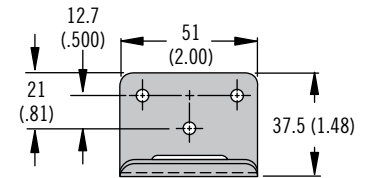
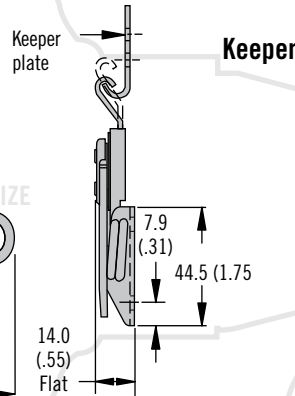
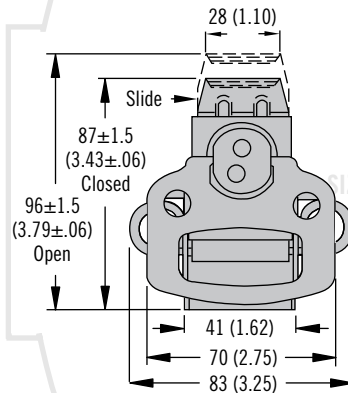

Spring Loaded (flat cam shown)

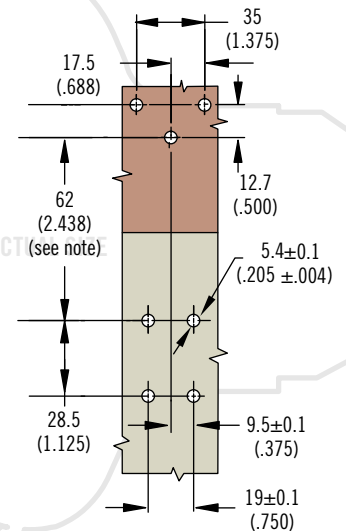
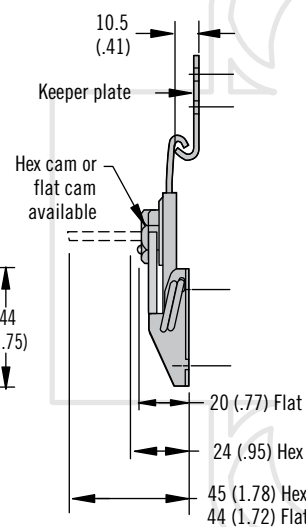
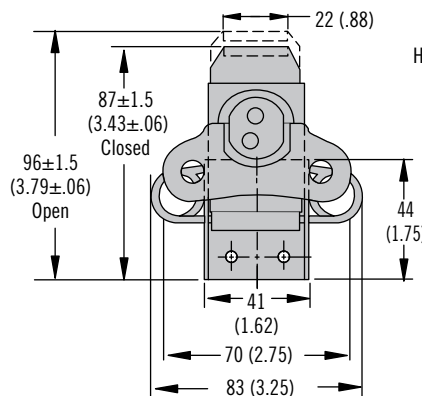

Part Number

See table

Order latch and keeper separately

Material	Part Number					
	Riveted Hex Cam	Riveted Flat Cam	Low Profile Flat Cam	Spring Loaded Hex Cam	Spring Loaded Flat Cam	Keeper
Steel	K5-2812-07	K5-2857-07	K5-2814-07	K5-2858-07	K5-2856-07	K5-2811-07
Stainless Steel	~	K5-2857-52	~	~	K5-2856-52	K5-2811-52

Dimensions in millimeters (inch) unless otherwise stated



www.southco.com/K5

K5 Draw Latch

Rotary · Large



Padlockable (riveted hex cam shown)

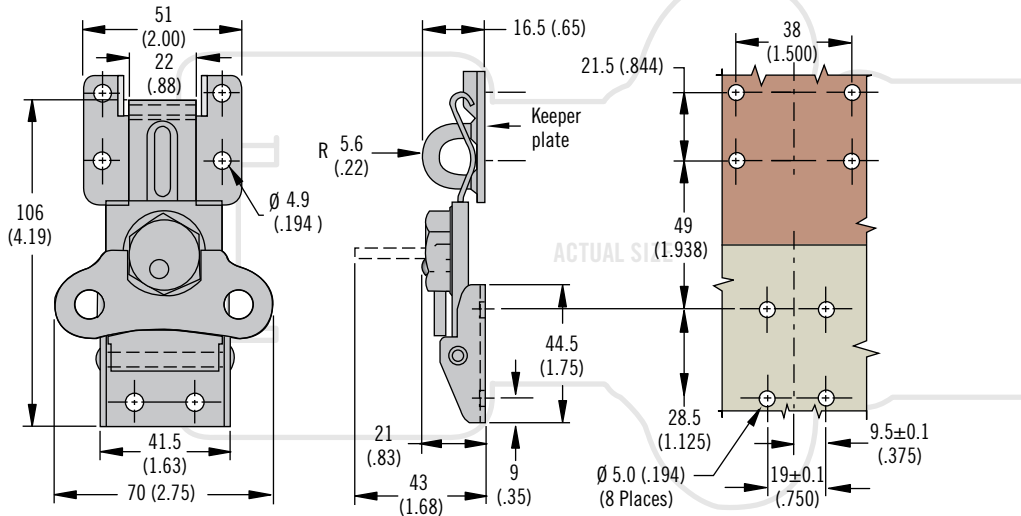

Key Lockable

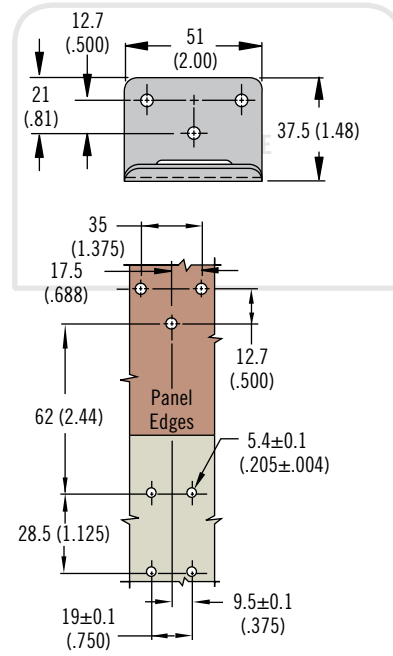
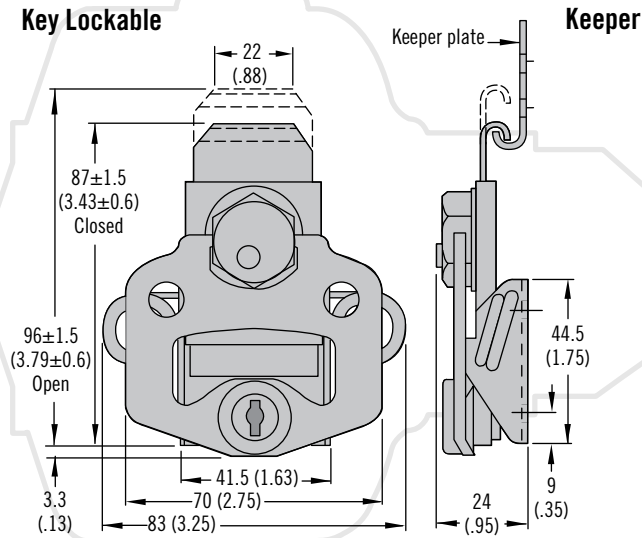

Tool Operated (spring loaded shown)

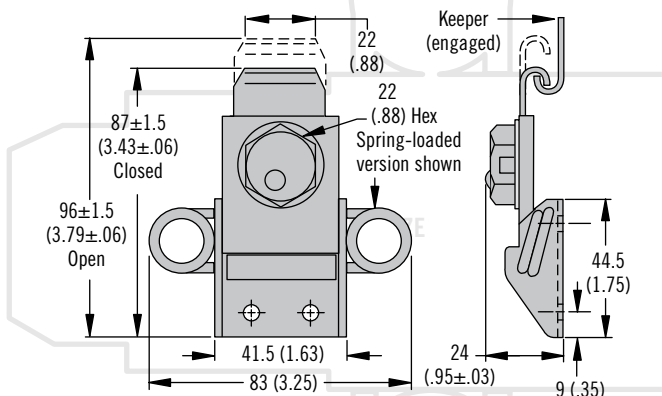

Latch Part Number	
Padlockable Riveted Hex Cam	K5-2754-07
Padlockable Riveted Flat Cam	K5-1993-07
Padlockable Flat Cam, Spring Loaded	K5-1994-07
Key Lockable	K5-2813-07
Tool Operated, Spring Loaded	K5-2819-07
Tool Operated, Riveted	K5-2818-07
Keeper Part Number	
Keeper	K5-2811-07
Keeper, Padlockable	K5-1736-07

- Lift and Turn operation
- Consistent pull-up

Material and Finish

Steel, zinc plated

Installation Notes

Install assembly with $\varnothing 5$ (3/16) rivets or M5 (No. 10) flat head screws (not supplied)

Notes

Spring loaded:
Ideal for applications where shock and vibration occur. Compensates up to 4 (.16) for mounting hole irregularities, panel variations and gasket set.

Part Number

See table

Order latch and keeper separately

Southco® Draw Latches

Link Lock Rotary Action Draw Latch, Medium Flat Cam Style

- Key-lockable, Small Wing or Large Wing Available
- Blade swings open when unlatched
- Accommodates off-plane latching

Small Wing

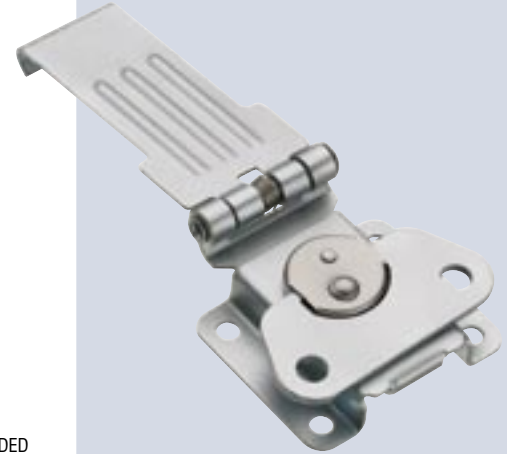
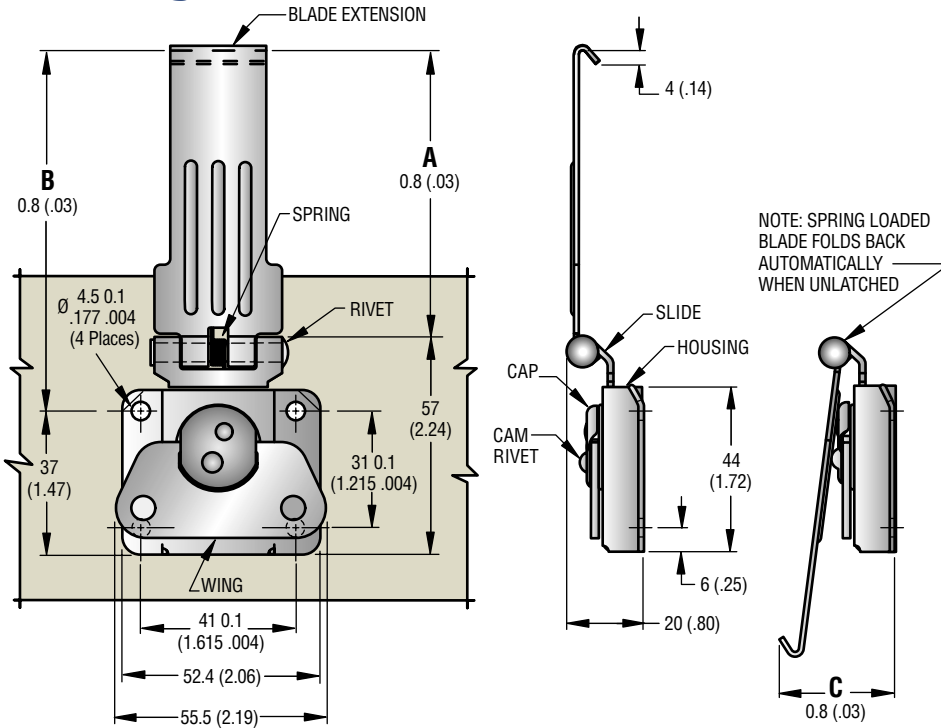

DIMENSIONS			PART NUMBERS
A	B	C	
49.7 (1.96)	69.6 (2.74)	25.6 (1.01)	K4-4004-07-1 •

Material and Finish

HOUSING, SLIDE and BLADE EXTENSION: 4130 Hardened steel, zinc plated plus bright chromate dip. RIVET: 1006 Steel, zinc plated plus bright chromate dip. SPRING and CAP: 302 Series stainless steel, natural. WING and LOWER CAM: 1020 Steel, zinc plated bright chromate dip. UPPER CAM: 304 Series stainless steel, natural. CAM RIVET: 300 Series stainless steel, natural.

Large Wing

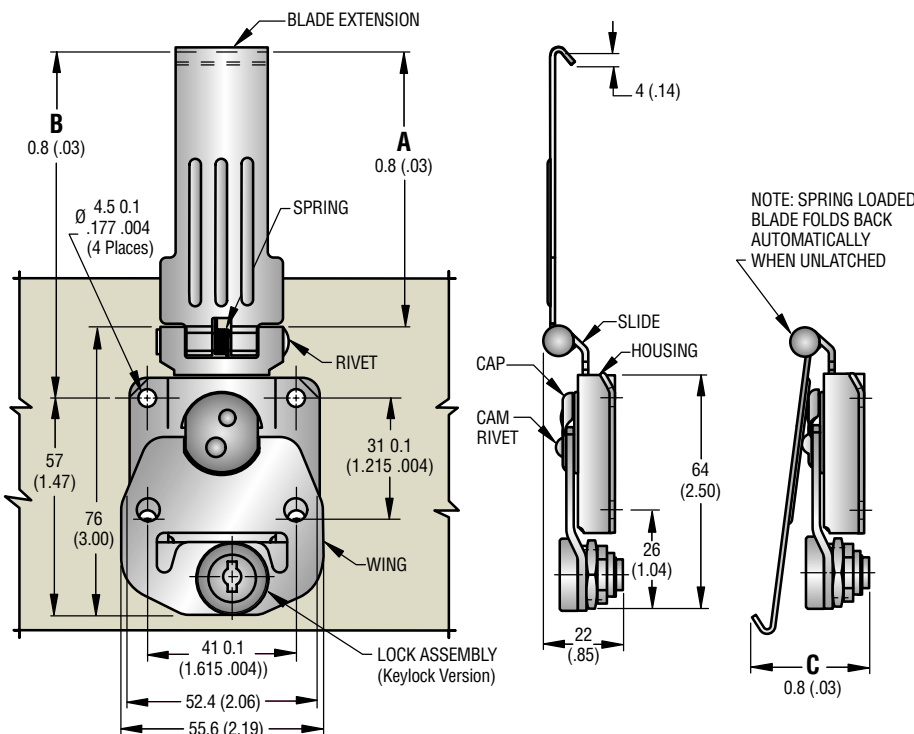

DIMENSIONS			PART NUMBERS KEY LOCK VERSION
A	B	C	
66.3 (2.61)	85.3 (3.36)	30.2 (1.19)	K4-4024-07-3 •
69.3 (2.73)	89.1 (3.51)	30.7 (1.21)	K4-4024-07-4 •
72.6 (2.86)	92.2 (3.63)	31.5 (1.24)	K4-4024-07-5 •

Material and Finish

HOUSING, SLIDE and BLADE EXTENSION: 4130 Hardened steel, zinc plated plus bright chromate dip. RIVET: 1006 Steel, zinc plated plus bright chromate dip. SPRING and CAP: 302 Series stainless steel, natural. WING and LOWER CAM: 1020 Steel, zinc plated bright chromate dip. UPPER CAM: 304 Series stainless steel, natural. CAM RIVET: 300 Series stainless steel, natural. LOCK PLUG: Die cast zinc, bright chrome plated. PAWL: Low carbon steel, zinc plated plus chromate dip. MOUNTING NUT: Brass, natural. KEYS: Low carbon steel, chrome plated.

millimeter (inch)
millimeter
(inch)

Dimensions without tolerances are for reference only.

* S-2500 latches can be used with No. K3, No. K4 or No. K5 Keeper plates.

Draw Latches
Steel/Stainless Steel

Southco® Draw Latches

Link Lock Rotary Action Draw Latch, Folding Blade Extensions

- Blade swings open when unlatched
- Latch can be recessed into a panel
- Accommodates off-plane latching

Series S-2000

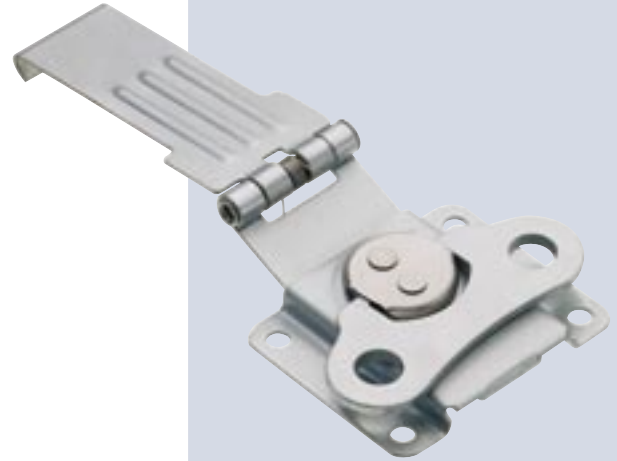
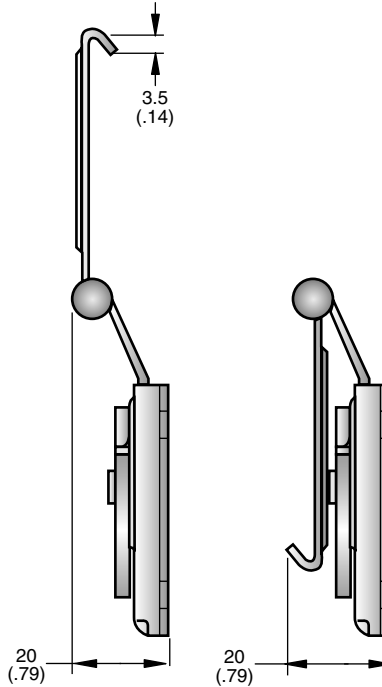
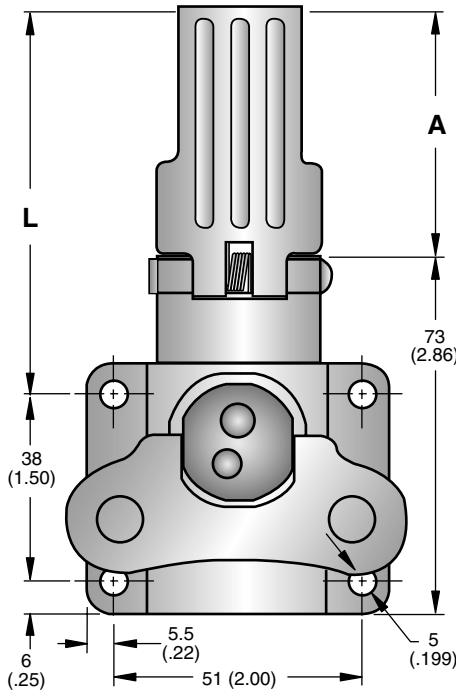

DIMENSIONS		PART NUMBERS
A	L	
51 (2.00)	79 (3.11)	K5-1974-07 •
63 (2.47)	91 (3.58)	K5-2200-07 •
67 (2.63)	95 (3.74)	K5-2207-07 •
70 (2.75)	98 (3.86)	K5-2242-07 •
76 (3.00)	104 (4.11)	K5-2216-07 •

Series S-3000

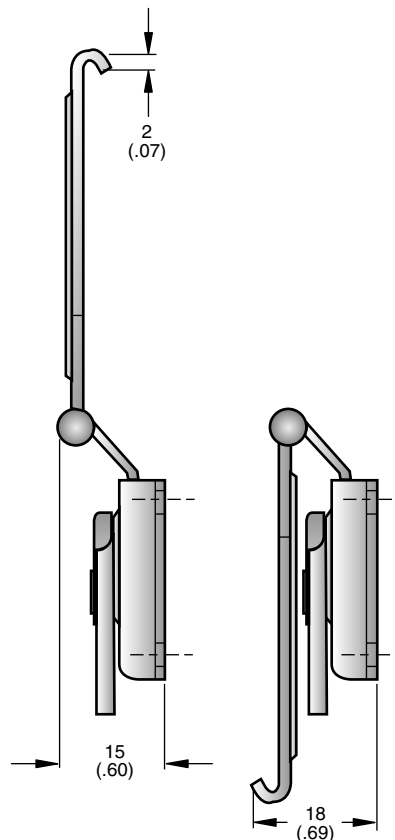
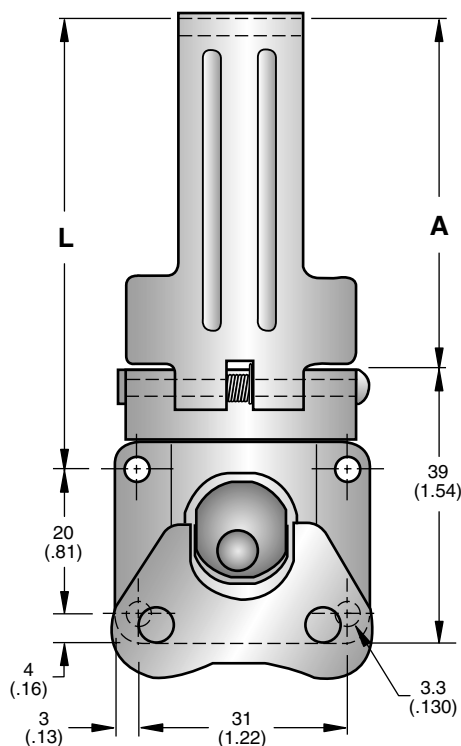

DIMENSIONS		PART NUMBERS
A	L	
54 (2.13)	69 (2.70)	K3-2436-07 •
67 (2.63)	81 (3.20)	K3-2468-07 •

Material and Finish

HOUSING, SLIDE and BLADE EXTENSION: Hardened alloy steel, zinc plated plus bright chromate dip.
 CAP, CAM RIVET and SPRINGS: 300 Series stainless steel.
 UPPER CAM (S-2000): 300 Series stainless steel.
 UPPER CAM: (S-3000): Carbon steel; zinc plated plus bright chromate dip.

millimeter (inch)
 millimeter
 (inch)

Dimensions without tolerances are for reference only.

* S-2000 and S-3000 latches can be used with Large, Medium or Miniature Keeper plates.