

1.5SMC*** ASeries

SURFACE MOUNT TRANSIENT VOLTAGE SUPPRESSOR
VOLTAGE 6.8 TO 480 Volts, 1500 Watt Peak Pulse Power

1. FEATURES

- We declare that the material of product compliance with RoHS requirements and Halogen Free.
- Plastic package has Underwriters Laboratory Flammability Classification 94V-O
- For surface mounted applications in order to optimize board space
- Low profile package
- Built-in strain relief
- Glass passivated junction
- Low inductance
- Excellent clamping capability
- Repetition Rate (duty cycle):0.01%
- Fast response time: typically less than 1.0ps
- Typical IR less than 1uA above 10V
- High temperature soldering guaranteed:
260°C/10 seconds,
- Weight: 0.26g



2.MECHANICAL DATA

Case: JEDEC DO-214AB (SMC)

Terminals: Plated leads, solderable per MIL-STD-202, Method 208

Polarity: Color band denoted cathode

Mounting Position: Any

3. MAXIMUM RATINGS(Ta = 25°C)

Ratings at 25°C ambient temperature unless otherwise specified.

Single phase, half wave, 60Hz, resistive or inductive load.

For capacitive load, derate current by 20%.

RATING	VALUE	UNITS
Peak Power Dissipation at T _A =25°C, T _P =1ms(Note 1)	Minimum1500	Watts
Steady State Power Dissipation at T _L =75°C(Note 2)	5.0	Watts
Peak Forward Surge Current,8.3ms Single Half Sine-Wave Superimposed on Rated Load, (JEDEC Method)(Note 3)	200	A
Operating Temperature Range	-55 to +150	°C
Storage Temperature Range	-55 to +150	°C

NOTES:

1. Non-repetitive current pulse, per Fig. 3 and derated above TA=25°C per Fig. 2.
2. Mounted on 0.31 x 0.31" (8.0 x 8.0mm) copper pads to each terminal.

1.5SMC*** A Series

Uni-Directional Part Number	Device marking code	Reverse Stand-off Voltage VRWM (V)	Breakdown Voltage VBR (V) Min. @IT	Breakdown Voltage VBR (V) Max. @IT	Test Current IT (mA)	Maximum Clamping Voltage @IPP VC (V)	Peak Pulse Current Ipp (A)	Reverse Leakage @VRWM IR (uA)
1.5SMC6.8A	1.5SMC6.8A	5.8	6.45	7.14	10	10.5	142.9	1000
1.5SMC7.5A	1.5SMC7.5A	6.4	7.13	7.88	10	11.3	132.7	500
1.5SMC8.2A	1.5SMC8.2A	7.02	7.79	8.61	10	12.1	124.0	200
1.5SMC9.1A	1.5SMC9.1A	7.78	8.65	9.5	1	13.4	111.9	50
1.5SMC10A	1.5SMC10A	8.55	9.5	10.5	1	14.5	103.4	10
1.5SMC11A	1.5SMC11A	9.4	10.5	11.6	1	15.6	96.2	1
1.5SMC12A	1.5SMC12A	10.2	11.4	12.6	1	16.7	89.8	1
1.5SMC13A	1.5SMC13A	11.1	12.4	13.7	1	18.2	82.4	1
1.5SMC15A	1.5SMC15A	12.8	14.3	15.8	1	21.2	70.8	1
1.5SMC16A	1.5SMC16A	13.6	15.2	16.8	1	22.5	66.7	1
1.5SMC18A	1.5SMC18A	15.3	17.1	18.9	1	25.2	59.5	1
1.5SMC20A	1.5SMC20A	17.1	19	21	1	27.7	54.2	1
1.5SMC22A	1.5SMC22A	18.8	20.9	23.1	1	30.6	49.0	1
1.5SMC24A	1.5SMC24A	20.5	22.8	25.2	1	33.2	45.2	1
1.5SMC27A	1.5SMC27A	24	25.7	28.4	1	37.5	40.0	1
1.5SMC30A	1.5SMC30A	25.6	28.5	31.5	1	41.4	36.2	1
1.5SMC33A	1.5SMC33A	28.2	31.4	34.7	1	45.7	32.8	1
1.5SMC36A	1.5SMC36A	30.8	34.2	37.8	1	49.9	30.1	1
1.5SMC39A	1.5SMC39A	33.3	37.1	41	1	53.9	27.8	1
1.5SMC43A	1.5SMC43A	36.8	40.9	45.2	1	59.3	25.3	1
1.5SMC47A	1.5SMC47A	40.2	44.7	49.4	1	64.8	23.1	1
1.5SMC51A	1.5SMC51A	43.6	48.5	53.6	1	70.1	21.4	1
1.5SMC56A	1.5SMC56A	47.8	53.2	58.8	1	77	19.5	1
1.5SMC62A	1.5SMC62A	53	58.9	65.1	1	85	17.6	1
1.5SMC68A	1.5SMC68A	58.1	64.6	71.4	1	92	16.3	1
1.5SMC75A	1.5SMC75A	64.1	71.3	78.8	1	103	14.6	1
1.5SMC82A	1.5SMC82A	70.1	77.9	86.1	1	113	13.3	1
1.5SMC91A	1.5SMC91A	77.8	86.5	95.5	1	125	12.0	1
1.5SMC100A	1.5SMC100A	85.5	95	105	1	137	10.9	1
1.5SMC110A	1.5SMC110A	94	105	116	1	152	9.9	1
1.5SMC120A	1.5SMC120A	102	114	126	1	165	9.1	1
1.5SMC130A	1.5SMC130A	111	124	137	1	179	8.4	1
1.5SMC150A	1.5SMC150A	128	143	158	1	207	7.2	1
1.5SMC160A	1.5SMC160A	136	152	168	1	219	6.8	1
1.5SMC170A	1.5SMC170A	145	162	179	1	234	6.4	1
1.5SMC180A	1.5SMC180A	154	171	189	1	246	6.1	1
1.5SMC200A	1.5SMC200A	171	190	210	1	274	5.5	1
1.5SMC220A	1.5SMC220A	185	209	231	1	328	4.6	1
1.5SMC250A	1.5SMC250A	214	237	263	1	344	4.4	1
1.5SMC300A	1.5SMC300A	256	285	315	1	414	3.6	1
1.5SMC350A	1.5SMC350A	300	333	367	1	482	3.1	1
1.5SMC400A	1.5SMC400A	342	380	420	1	548	2.7	1
1.5SMC440A	1.5SMC440A	376	418	462	1	602	2.5	1
1.5SMC480A	1.5SMC480A	408	456	504	1	658	2.3	1

5. ELECTRICAL CHARACTERISTICS CURVES

Fig. 1-Peak Pulse Power Rating Curve

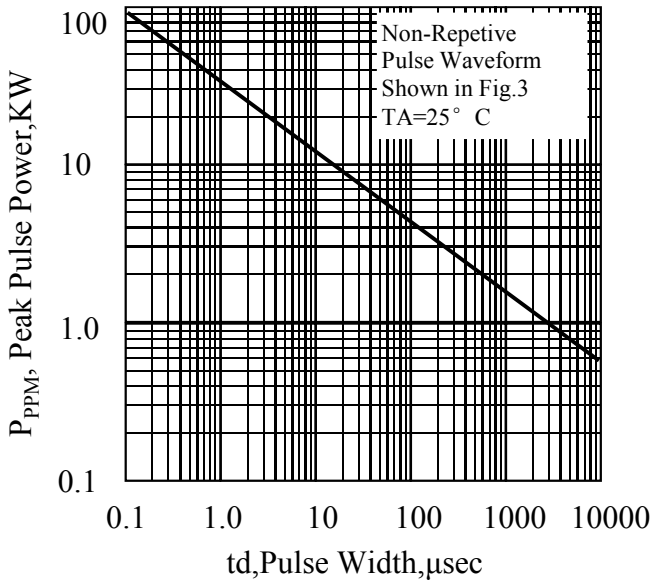

Fig. 2-Pulse Derating Curve

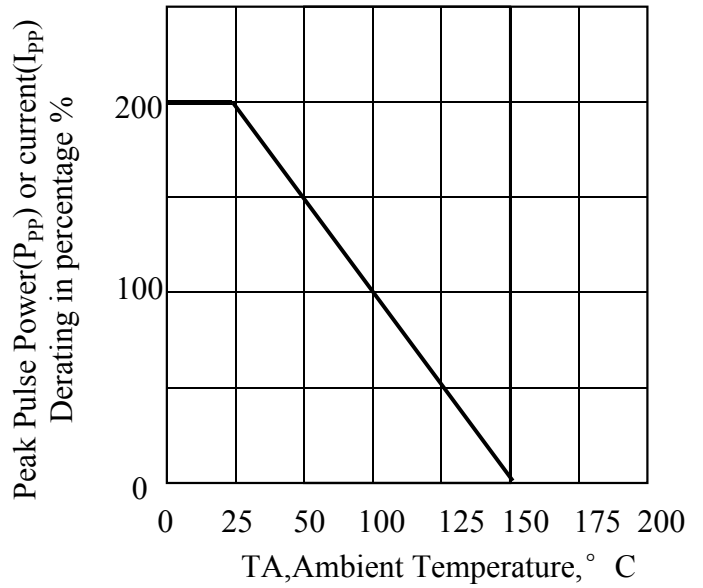

Fig. 3-Pulse Waveform

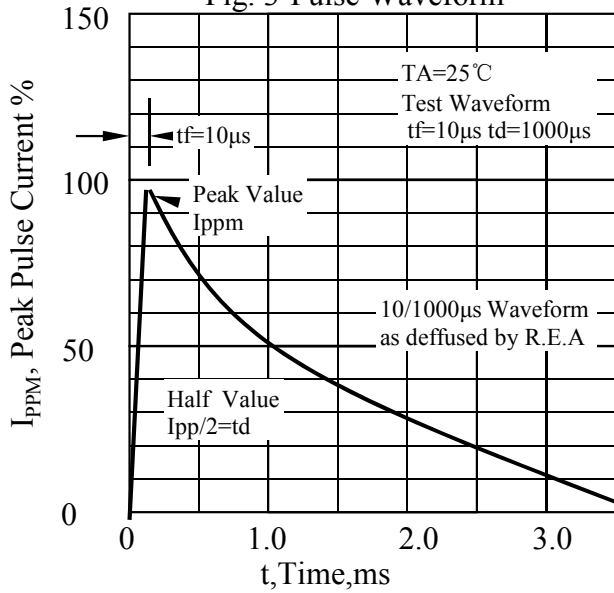
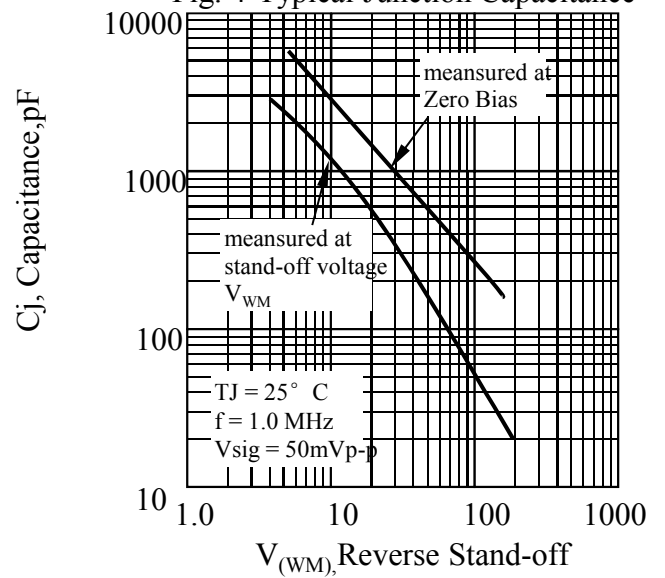
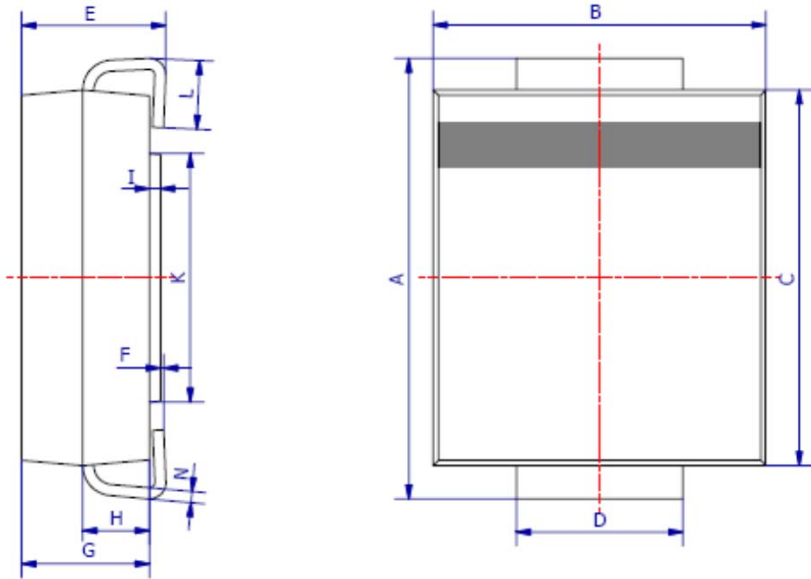

Fig. 4-Typical Junction Capacitance



6. OUTLINE AND DIMENSIONS



SMC			
DIM	Min	Max	Typ.
A	7.70	8.30	8.00
B	5.85	6.25	6.05
C	6.65	7.05	6.85
D	2.80	3.20	3.00
E	2.45	2.85	2.65
G	2.10	2.50	2.30
H	1.00	1.40	1.20
I	0.05	0.15	0.10
K	4.30	4.70	4.50
L	1.00	1.50	1.25
N	0.10	0.30	0.20
All Dimensions in mm			

7. SOLDERING FOOTPRINT

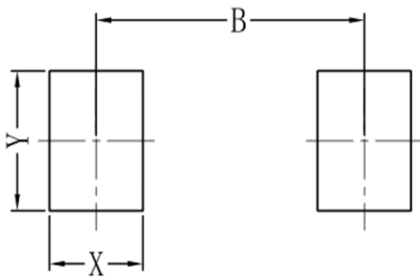

SMC	
DIM	(mm)
X	1.60
Y	3.30
B	6.60