

SL 87 WPM

Art. No. 2087 – 4 Ω

Art. No. 2088 – 8 Ω

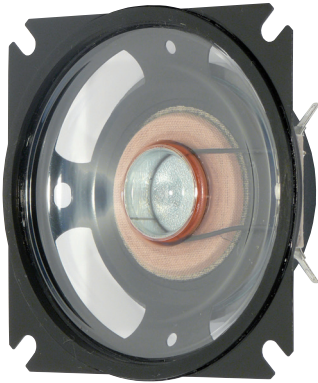

Art. No. 4639 **)

Wasserfester 8 cm (3,3") Breitbandlautsprecher mit transparenter Kunststoffmembran und Gummidichtring. Hoher Kennschalldruckpegel und flache Bauform. Optimiert für Sprach- und Signalwiedergabe.

Anwendungsmöglichkeiten: Kontroll-Lautsprecher für elektronische Geräte, Außenbeschallungen

Zubehör: Schutzgitter (Art. No. 4639)

Waterproof 8 cm (3.3") fullrange speaker with a transparent plastic cone and rubber sealing ring. High mean sound pressure level and compact design. Optimised for voice and signal output.

Typical applications: Control speaker for electronic devices, Outdoor sound reinforcement systems

Accessories: Protective grille (Art. No. 4639)

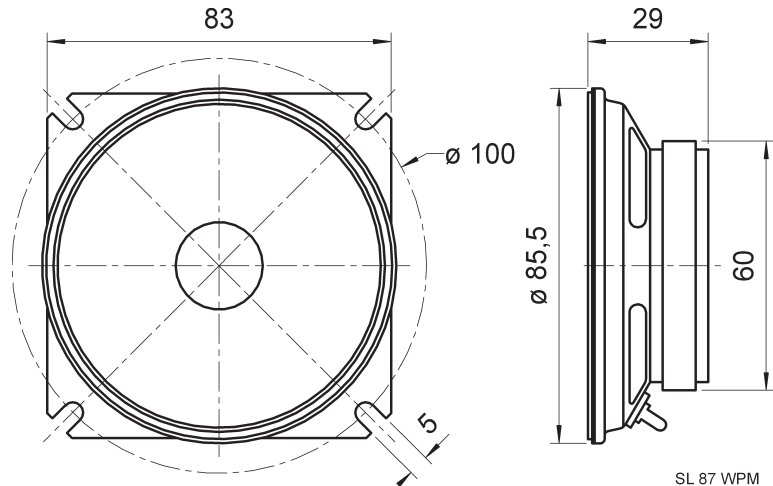

SL 87 WPM
02.02.07

Technische Daten / Technical Data

Nennbelastbarkeit	
Rated power	20 W
Musikbelastbarkeit	
Maximum power	30 W
Impedanz	
Impedance	4 Ω / 8 Ω
Übertragungsbereich (-10 dB)	
Frequency response (-10 dB)	200–5000 Hz
Mittlerer Schalldruckpegel	
Mean sound pressure level	89 dB (1 W/1 m)
Grenzauslenkung x_{mech}	
Excursion limit x_{mech}	± 1,5 mm
Resonanzfrequenz	
Resonant frequency	290 Hz
Obere Polplattenhöhe	
Height of front pole-plate	3 mm
Schwingspulendurchmesser	
Voice coil diameter	20 mm Ø
Wickelhöhe	
Height of winding	5 mm
Schallwandöffnung	
Cut-out diameter	80 mm Ø
Gewicht netto	
Net weight	0,24 kg

*) Für Frontseite bei Einbau in ein abgedichtetes Gehäuse
For front side when built into a sealed enclosure

**) Details und Zeichnungen siehe Seite 267–271 /
Details and drawings see page 267–271

SL 87 WPM - 4 Ohm

