

PRODUCT DESCRIPTION CODE :

10131931-YXXXLF

PLATING :

- 1 = 0.76 μm GOLD ON CONTACT AREA
2.00 μm MIN MATTE TIN ON TAIL
- 2 = 0.38 μm GOLD ON CONTACT AREA
2.00 μm MIN MATTE TIN ON TAIL
- 3 = 0.20 μm GOLD ON CONTACT AREA
2.00 μm MIN MATTE TIN ON TAIL
- 4 = 0.76 μm GXT ON CONTACT AREA
2.00 μm MIN MATTE TIN ON TAIL
- 5 = 0.38 μm GXT ON CONTACT AREA
2.00 μm MIN MATTE TIN ON TAIL
- 6 = 0.20 μm GXT ON CONTACT AREA
2.00 μm MIN MATTE TIN ON TAIL
- 9 = 2.54 μm MIN MATTE TIN ON CONTACT AREA
2.00 μm MIN MATTE TIN ON TAIL
- 1.27 μm NICKEL MIN UNDERLAYER

RoHS COMPATIBLE, SEE NOTE 3
 PACKAGING : "A" : TAPE & REEL
 "U" : TUBE
 TOTAL NUMBER OF POSITIONS 02 TO 25

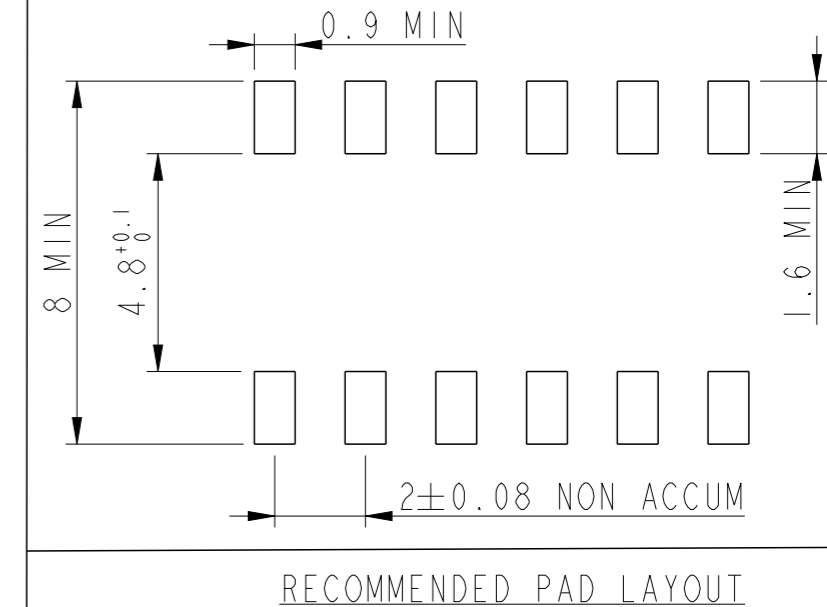
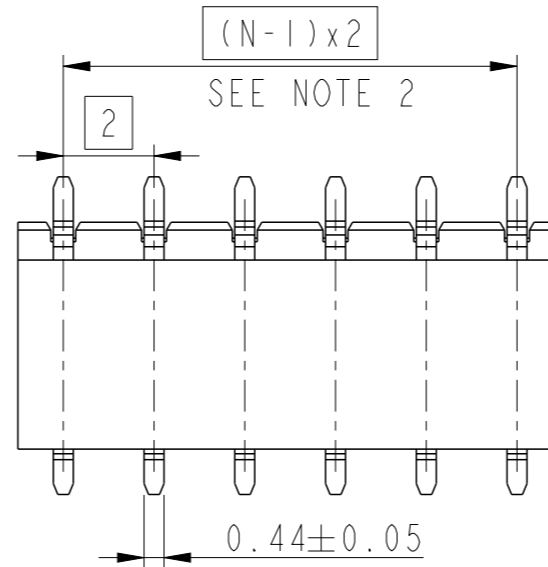

NOTES :

1- MATERIAL
 HOUSING : HIGH TEMPERATURE GLASS FILLED FLAME
 RETARDANT PER UL 94 V-0
 TERMINAL: COPPER ALLOY

2- TO DETERMINE DIMENSIONS :
 N = NUMBER OF POSITIONS PER ROW
 EXAMPLE : 8 POS N x 2 = 16mm
 UP TO N = 12 TOLERANCE : 0
 -0.10
 FROM N = 13 TOLERANCE : 0.05
 -0.10

3 - RoHS COMPATIBLE PRODUCT SPECIFICATIONS
 a - PLATING :
 "LF" MEANS THE PRODUCT IS LEAD-FREE, 2 μm MINIMUM MATTE
 TIN OVER 1.27 μm MINIMUM NICKEL UNDERPLATE
 b - MANUFACTURING PROCESS COMPATIBILITY
 THE HOUSING WILL WITHSTAND EXPOSURE TO 260°C PEAK
 TEMPERATURE FOR 30 SECONDS MAX IN A CONVECTION, INFRA-RED
 OR VAPOR PHASE OR REFLOW OVEN

c - LABELLING :
 MEETS PACKAGING SPECS AS PER GS-14-920
 d - LEGAL STATEMENT : SEE GS-47-0004

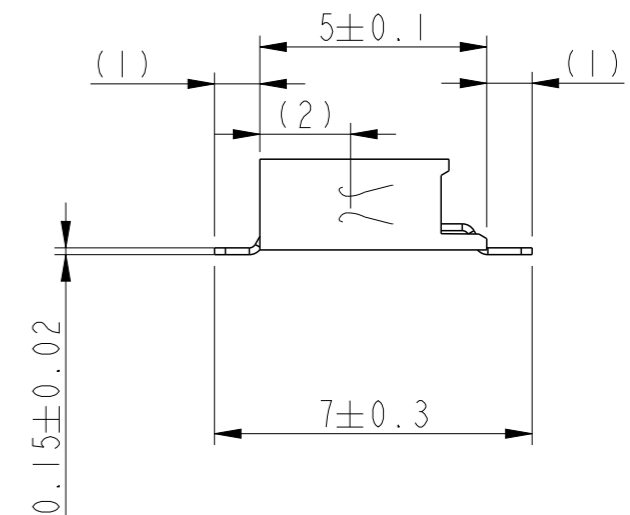
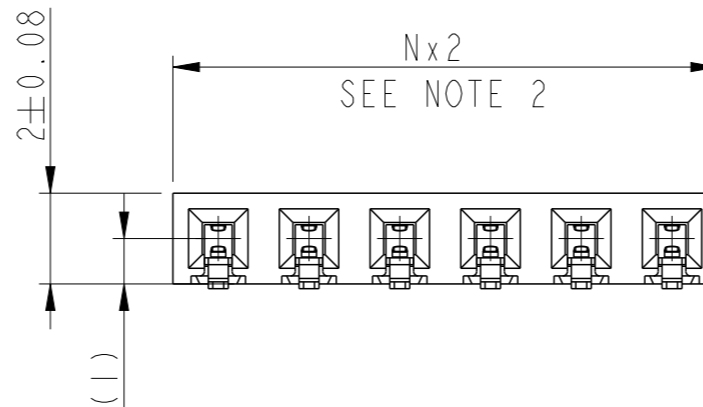

spec ref	GS-12-1326	dr	Cyril Jeune	2014/12/02	projection	mm	size	A3	scale	6:1
tolerance std	ISO 406 ISO 1101	eng	Detouillon, Da	2020/12/23		mm	ecn no	-	rel level	Released
	TOLERANCES UNLESS OTHERWISE SPECIFIED	chr	-	-						
surface	linear	appr	Wollin, Severi	2020/12/21	product family	-				
	angular									
	0.X ±	Amphenol FCI www.fci.com		MINITEK RECEPTACLE 2MM ASSEMBLY HCC SR SMT		dwg no 10131931		rev A		
	0.XX ±									
	0.XXX ±									
	0° ±	cat. no.	-	Product - Customer Drw	sheet 1 of 1					