

Synchronous rectifier smart driver for LLC resonant converters

Datasheet - production data

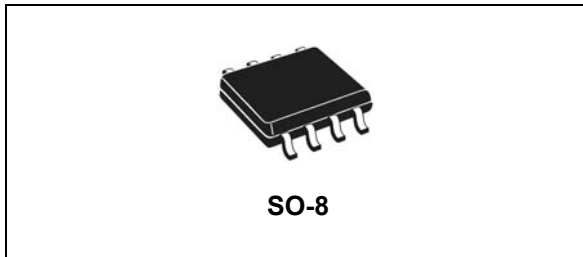

Features

- Secondary side synchronous rectifier controller optimized for LLC resonant converters
- Protection against current reversal
- Safe management of load transient, light load and startup condition
- Matched turn-off thresholds
- Intelligent automatic sleep mode at light load
- Dual gate driver for N-channel MOSFETs with 1 A source and 3.5 A sink drive current
- Operating voltage range 4.5 to 32 V
- Programmable UVLO with hysteresis
- 250 μ A quiescent consumption
- Operating frequency up to 500 kHz
- Available in SO-8 package

Applications

- All-in-one PC
- High-power AC-DC adapters
- 80+/85+ compliant ATX SMPS
- 90+/92+ compliant server SMPS
- Industrial SMPS

Description

The SRK2000A smart driver implements a control scheme specific to secondary side synchronous rectification in LLC resonant converters that use a transformer with center tap secondary winding for full wave rectification.

It provides two high current gate drive outputs, each capable of driving one or more N-channel Power MOSFETs. Each gate driver is controlled separately and an interlocking logic circuit prevents the two synchronous rectifier MOSFETs from conducting simultaneously.

The control scheme in this IC allows for each synchronous rectifier to be switched on as the corresponding half-winding starts conducting and switched off as its current goes to zero. The SRK2000A device implements matched turn-off MOSFET thresholds. A unique feature of this IC is its intelligent automatic sleep mode. It allows the detection of a low-power operating condition for the converter and puts the IC into a low consumption sleep mode where gate driving is stopped and quiescent consumption is reduced. In this way, converter efficiency improves at light load, where synchronous rectification is no longer beneficial. The IC automatically exits sleep mode and restarts switching as it recognizes that the load for the converter has increased.

A noticeable feature is the very low external component count required.

Table 1. Device summary

Order code	Package	Packing
SRK2000A	SO-8	Tube
SRK2000ATR		Tape and reel

Contents

- 1 Internal block diagram 3**
- 2 Pin description 4**
- 3 Maximum ratings 6**
- 4 Typical application schematic 6**
- 5 Electrical characteristics 7**
- 6 Application information 9**
 - 6.1 EN pin - pin function and usage 9
 - 6.1.1 Pull-up resistor configuration 9
 - 6.1.2 Resistor divider configuration 10
 - 6.1.3 Remote on/off control 11
 - 6.2 Drain voltage sensing 12
 - 6.3 Gate driving 14
 - 6.4 Intelligent automatic sleep mode 14
 - 6.5 Protection against current reversal 15
 - 6.6 Layout guidelines 15
- 7 Package information 16**
 - 7.1 SO-8 package information 17
- 8 Revision history 18**



1 Internal block diagram

Figure 1. Internal block diagram

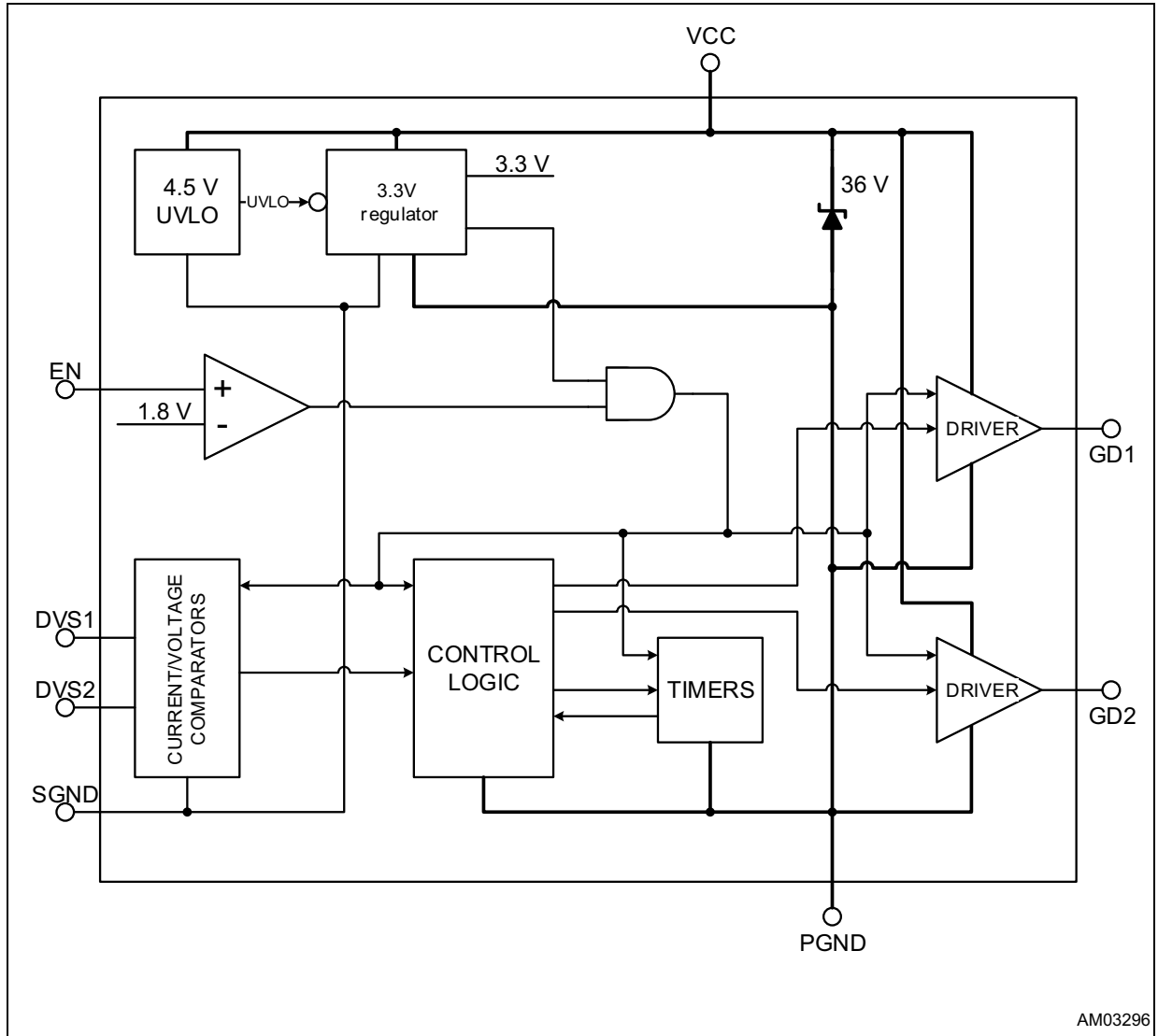

AM03296

2 Pin description

Figure 2. Pin configuration

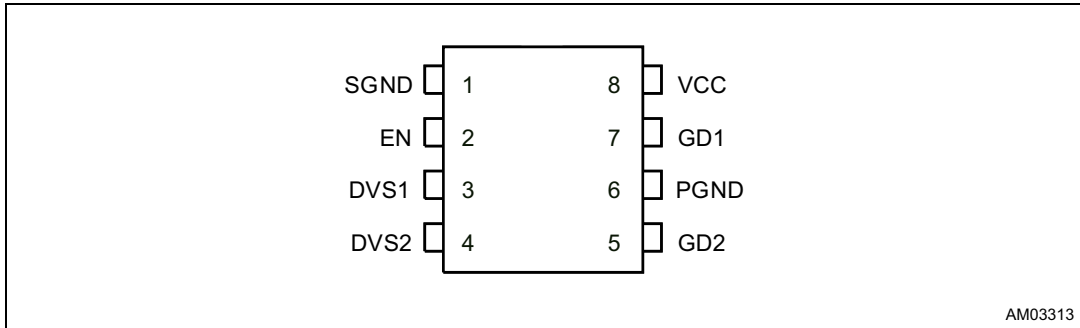
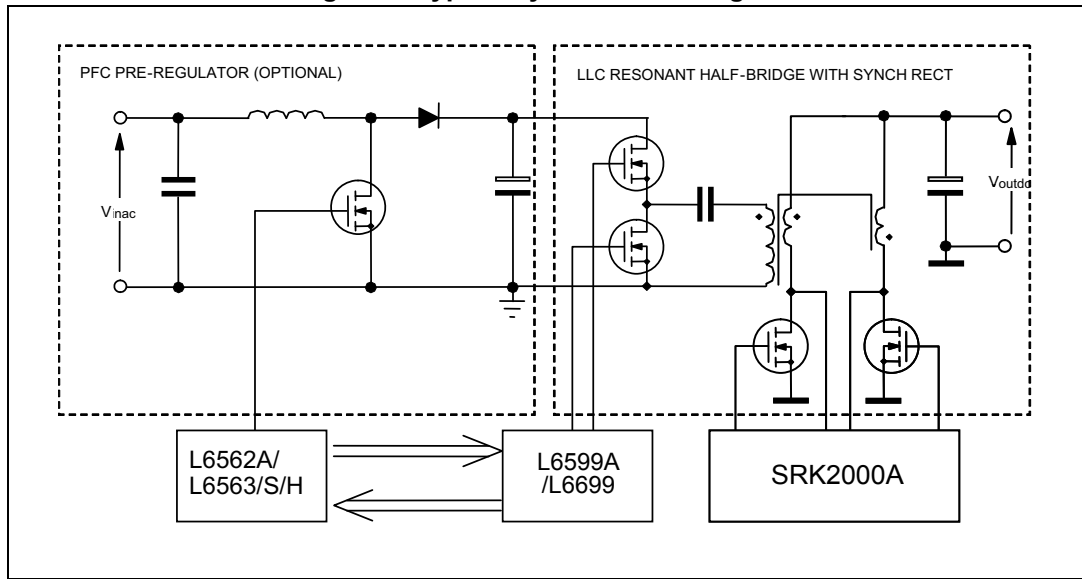

Table 2. Pin description

No.	Name	Function
1	SGND	Signal ground. Return of the bias current of the device and 0 V reference for drain-to-source voltage monitors of both sections. Route this pin directly to PGND.
2	EN	Drain voltage threshold setting for synchronous rectifier MOSFET turn-off. UVLO threshold programming. This pin is typically biased by either a pull-up resistor connected to V_{CC} or by a resistor divider sensing V_{CC} . Pulling the pin to ground disables the gate driver outputs GD1 and GD2 and can therefore be used also as Enable input.
3 4	DVS1 DVS2	Drain voltage sensing for sections 1 and 2. These pins are to be connected to the respective drain terminals of the corresponding synchronous rectifier MOSFET via limiting resistors. When the voltage on either pin goes negative, the corresponding synchronous rectifier MOSFET is switched on; as its (negative) voltage exceeds a threshold defined by the EN pin, the MOSFET is switched off. An internal logic rejects switching noise, however, extreme care in the proper routing of the drain connection is recommended.
5 7	GD2 GD1	Gate driver output for sections 2 and 1. Each totem pole output stage is able to drive the Power MOSFETs with a peak current of 1 A source and 3.5 A sink. The high-level voltage of these pins is clamped at about 12 V to avoid excessive gate voltages in case the device is supplied with a high V_{CC} .
6	PGND	Power ground. Return for gate drive currents. Route this pin to the common point where the source terminals of both synchronous rectifier MOSFETs are connected.
8	V_{CC}	Supply voltage of the device. A small bypass capacitor (0.1 μ F typ.) to SGND, located as close to the IC's pins as possible, may be useful to obtain a clean supply voltage for the internal control circuitry. A similar bypass capacitor to PGND, again located as close to the IC's pins as possible, may be an effective energy buffer for the pulsed gate drive currents.

Figure 3. Typical system block diagram



3 Maximum ratings

Table 3. Absolute maximum ratings

Symbol	Pin	Parameter	Value	Unit
V_{CC}	8	DC supply voltage	-0.3 to V_{CCZ}	V
I_{CCZ}	8	Internal Zener maximum current	25	mA
---	2, 3, 4	Analog inputs voltage rating	-0.3 to V_{CCZ}	V
$I_{DVS1,2_sk}$	3, 4	Analog inputs max. sink current (single pin)	25	mA
$I_{DVS1,2_sr}$	3, 4	Analog inputs max. source current (single pin)	-5	mA

Table 4. Thermal data

Symbol	Parameter	Value	Unit
R_{thJA}	Max. thermal resistance, junction to ambient	150	°C/W
P_{tot}	Power dissipation at $T_A = 50\text{ °C}$	0.65	W
T_J	Junction temperature operating range	-40 to 150	°C
T_{stg}	Storage temperature	-55 to 150	°C

4 Typical application schematic

Figure 4. Typical application schematic

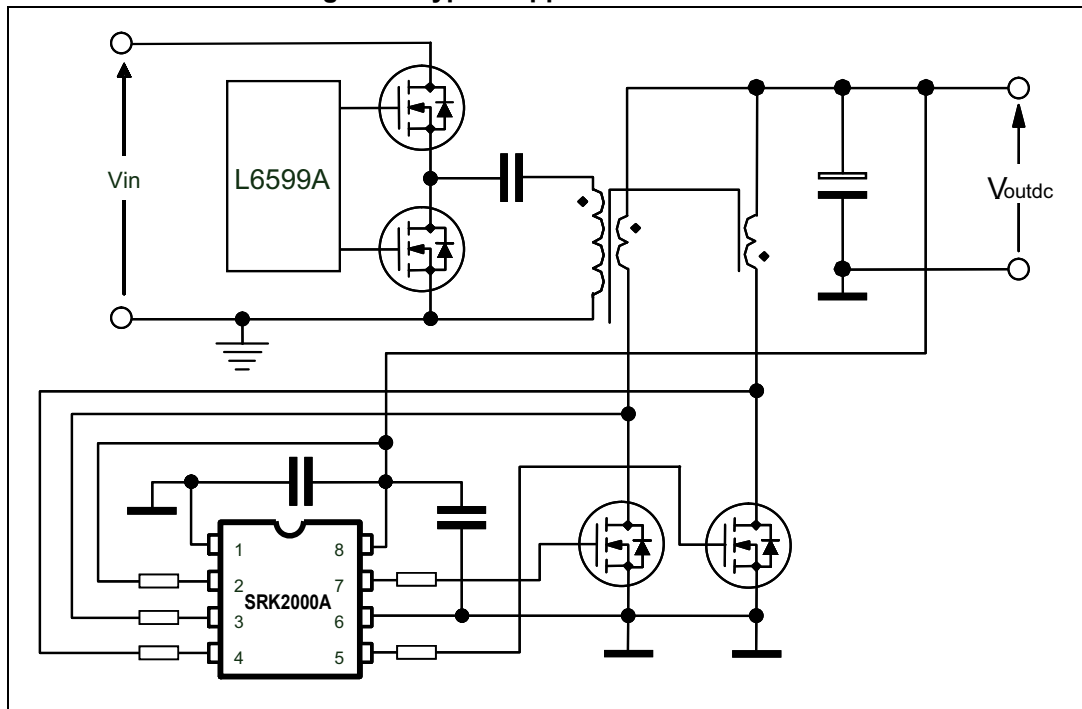

5 Electrical characteristics

$T_J = -25$ to 125 °C, $V_{CC} = 12$ V, $C_{GD1} = C_{GD2} = 4.7$ nF, $EN = V_{CC}$; unless otherwise specified; typical values refer to $T_J = 25$ °C.

Table 5. Electrical characteristics

Symbol	Parameter	Test condition	Min.	Typ.	Max.	Unit
Supply voltage						
V_{CC}	Operating range	After turn-on	4.5	-	32	V
V_{CCOn}	Turn-on threshold	See ⁽¹⁾	4.25	4.5	4.75	V
V_{CCOff}	Turn-off threshold	See ⁽¹⁾	4	4.25	4.5	V
Hys	Hysteresis	-	-	0.25	-	V
V_{CCZ}	Zener voltage	$I_{CCZ} = 20$ mA	33	36	39	V
Supply current						
$I_{start-up}$	Startup current	Before turn-on, $V_{CC} = 4$ V	-	45	70	μA
I_q	Quiescent current	After turn-on	-	250	500	μA
I_{CC}	Operating supply current	At 300 kHz	-	35	-	mA
I_q	Quiescent current	$EN = SGND$	-	150	250	μA
Drain sensing inputs and synch functions						
$V_{DVS1,2_H}$	Upper clamp voltage	$I_{DVS1,2} = 20$ mA	-	V_{CCZ}	-	V
$I_{DVS1,2_b}$	Input bias current	$V_{DVS1,2} = 0$ to V_{CC} ⁽²⁾	-1		1	μA
$V_{DVS1,2_A}$	Arming voltage (positive-going edge)	-	-	1.4	-	V
$V_{DVS1,2_PT}$	Pre-triggering voltage (negative-going edge)	-	-	0.7	-	V
$V_{DVS1,2_TH}$	Turn-on threshold	-	-250	-200	-180	mV
$I_{DVS1,2_On}$	Turn-on source current	$V_{DVS1,2} = -250$ mV	-	-50	-	μA
$V_{DVS1,2_Off}$	Turn-off threshold (positive-going edge)	$R = 680$ kΩ from EN to V_{CC}	-18	-25	-32	mV
		$R = 270$ kΩ from EN to V_{CC}	-9	-12.5	-16	
$V_{DVS1,2_Off_match}$	Matching between the two turn-off thresholds	-	-	1	-	mV
T_{PD_On}	Turn-on debounce delay	After sourcing $I_{DS1,2_On}$	-	250	-	ns
T_{PD_Off}	Turn-off propagation delay	After crossing $V_{DS1,2_Off}$	-	-	60	ns
T_{ON_min}	Minimum on-time	-	-	150	-	ns
D_{OFF}	Min. operating duty-cycle	-	-	40	-	%
D_{ON}	Restart duty-cycle	-	-	60	-	%

Table 5. Electrical characteristics (continued)

Symbol	Parameter	Test condition	Min.	Typ.	Max.	Unit
Gate drive enable function						
V_{EN_On}	Enable threshold	Positive-going edge ⁽¹⁾	1.7	1.8	1.9	V
Hyst	Hysteresis	Below V_{EN_On}	-	45	-	mV
I_{EN}	Bias current	$V_{EN} = V_{EN_On}$	-	-	1	μ A
Turn-off threshold selection						
V_{EN_Th}	Selection threshold	$V_{CC} = V_{CCOn}$	0.32	0.36	0.40	V
I_{EN}	Pull-down current	$V_{EN} = V_{EN_Th}, V_{CC} = V_{CCOn}$	7	10	13	μ A
Gate drivers						
V_{GDH}	Output high voltage	$I_{GDsource} = 5\text{ mA}$	11.75	11.9	-	V
		$I_{GDsource} = 5\text{ mA}, V_{CC} = 5\text{ V}$	4.75	4.9	-	
V_{GDL}	Output low voltage	$I_{GDsink} = 200\text{ mA}$	-	0.2	-	V
		$I_{GDsink} = 200\text{ mA}, V_{CC} = 5\text{ V}$	-	0.2	-	
$I_{sourcepk}$	Output source peak current	-	-	-1	-	A
I_{sinkpk}	Output sink peak current	-	-	3.5	-	A
t_f	Fall time	-	-	18	-	ns
t_r	Rise time	-	-	40	-	ns
$V_{GDclamp}$	Output clamp voltage	$I_{GDsource} = 5\text{ mA}; V_{CC} = 20\text{ V}$	12	13	15	V
V_{GDL_UVLO}	UVLO saturation	$V_{CC} = 0\text{ to }V_{CCOn}$ $I_{sink} = 5\text{ mA}$	-	1	1.3	V

- Parameters tracking each other.
- For $V_{CC} > 30\text{ V}$ $I_{DVS1,2,b}$ may be greater than 1 μ A because of the possible current contribution of the internal clamp Zener (few tens of μ A).

6 Application information

6.1 EN pin - pin function and usage

This pin can perform three different functions: it sets the threshold $V_{DVS1,2_Off}$ for the drain-to-source voltage of either synchronous rectifier (SR) Power MOSFET to determine their turn-off in each conduction cycle; it allows the user to program the UVLO thresholds of the gate drivers and can be used as Enable (remote on/off control).

6.1.1 Pull-up resistor configuration

At startup, an internal 10 μA current sink (I_{EN}) is active as long as the device supply voltage V_{CC} is below the startup threshold V_{CCOn} . The moment V_{CC} equals V_{CCOn} (4.5 V typ.), the voltage V_{EN} on the EN pin determines the turn-off threshold $V_{DVS1,2_Off}$ for the drain voltage of both synchronous rectifiers during their cycle-by-cycle operation: if $V_{EN} < V_{EN_Th}$ (= 0.36 V) the threshold is set at -25 mV, otherwise at -12 mV. Once the decision is made, the setting is frozen as long as V_{CC} is greater than the turn-off level V_{CCOff} (4.25 V typ.).

A simple pull-up resistor R_1 to V_{CC} can be used to set $V_{DVS1,2_Off}$ turn-off threshold. The voltage on the EN pin as the device turns on is given by:

Equation 1

$$V_{EN} = V_{CCOn} - I_{EN} R_1$$

Then, considering worst-case scenarios, we have:

Equation 2

$$R_1 > 633 \text{ k}\Omega \rightarrow V_{DVS1,2_Off} = -25 \text{ mV}$$

$$R_1 < 296 \text{ k}\Omega \rightarrow V_{DVS1,2_Off} = -12 \text{ mV}$$

Some additional margin (equal to the resistor's tolerance) needs to be considered; assuming 5% tolerance, the use of the standard values $R_1 = 680 \text{ k}\Omega$ in the first case and $R_1 = 270 \text{ k}\Omega$ in the second case, is suggested.

Figure 5. EN pin biased with a pull-up resistor (for logic level MOSFET driving)

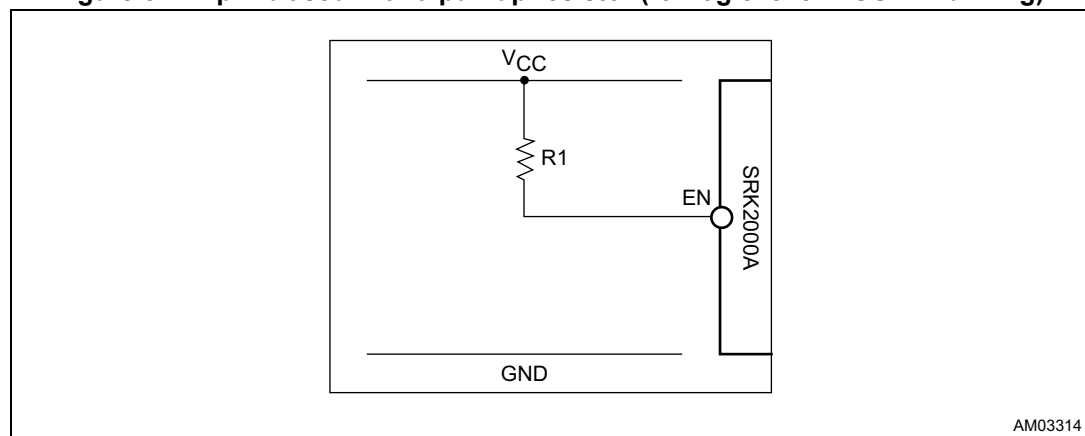

As V_{CC} exceeds V_{CCOn} , the internal current sink I_{EN} is switched off and the enable function is activated. The voltage on the pin is then compared to an internal reference V_{EN_On} set at 1.8 V: if this threshold is exceeded the gate drivers GD1 and GD2 are enabled and the SR MOSFET is operated; otherwise, the device stays in an idle condition and the SR MOSFET in the off state.

Using the pull-up resistor R_p , the voltage on the EN pin rises as I_{EN} is switched off and tends to V_{CC} , therefore exceeding V_{EN_On} and enabling the operation of both SR MOSFETs. Essentially, this results in enabling the gate-driving as V_{CC} exceeds V_{CCOn} and disabling it as V_{CC} falls below V_{CCOn} . This configuration is thereby recommended when SR MOSFETs are logic level types.

6.1.2 Resistor divider configuration

To enable gate-driving with a V_{CC} voltage higher than a predefined value V_{CC_G} to properly drive a standard SR MOSFET, the EN pin is biased by a resistor divider (R1 upper resistor, R2 lower resistor) whose value is chosen so as to exceed V_{EN_On} when $V_{CC} = V_{CC_G}$ and also to set the desired $V_{DVS1,2_Off}$ level. Note that, with a falling V_{CC} , gate-driving is disabled at a V_{CC} level about 2.5% lower than V_{CC_G} because of the 45 mV hysteresis of the comparator.

The equations that describe the circuit in the two crucial conditions $V_{CC} = V_{CCOn}$ (when the decision of the $V_{DVS1,2_Off}$ level is made) and $V_{CC} = V_{CC_G}$ (when gate-driving is to be enabled) are respectively:

Figure 6. EN pin biased with a resistor divider to program the gate drive UVLO threshold V_{CC_G}

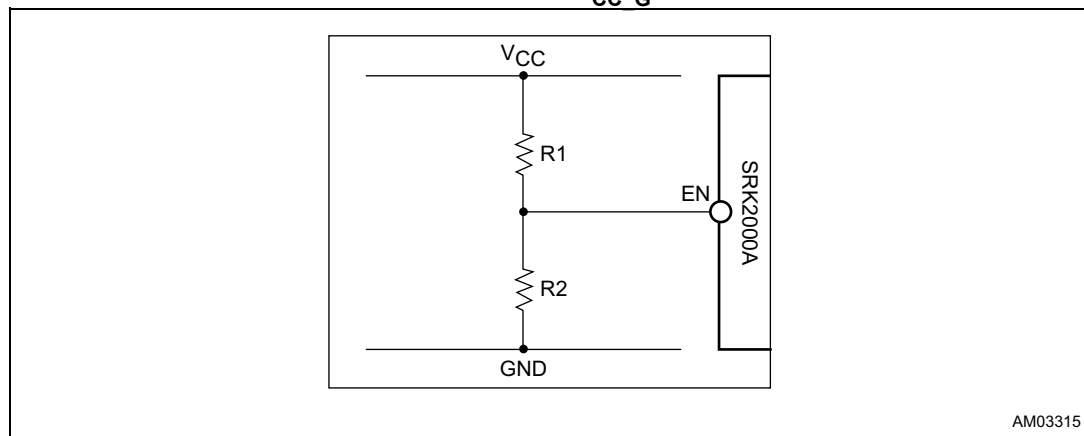

Equation 3

$$\begin{cases} \frac{V_{CCOn} - V_{EN}}{R1} = I_{EN} + \frac{V_{EN}}{R2} \\ V_{CC_G} \frac{R2}{R1+R2} = V_{EN_On} \end{cases}$$

Solving these equations for R_1 and R_2 we get:

Equation 4

$$\begin{cases} R1 = \frac{V_{CCOn} - V_{EN} \frac{V_{CC_G}}{V_{EN_On}}}{I_{EN}} \\ R2 = R1 \frac{V_{EN_On}}{V_{CC_G} - V_{EN_On}} \end{cases}$$

If V_{CC_G} is not too low ($< 8 \div 9$ V), its tolerance is not critical because it is related only to that of V_{EN_On} ($\pm 5.6\%$) and of the external resistors R_1 , R_2 ($\pm 1\%$ each is recommended). Then, some care needs to be taken only as far as the selection of the -12/-25 mV threshold is concerned: in fact, the large spread of I_{EN} considerably affects the voltage on the EN pin as the device turns on, a value that can be found by solving the first of (1) for V_{EN} :

Equation 5

$$V_{EN} = \frac{V_{CCOn} - I_{EN} R1}{1 + \frac{R1}{R2}}$$

A couple of examples clarify the suggested calculation methodology.

Example 1 $V_{CC_G} = 10$ V, $V_{DVS1,2_Off} = -25$ mV.

In this case, V_{EN} must definitely be lower than the minimum value of V_{EN_Th} ($= 0.32$ V). From the second of (2), the nominal ratio of R_1 to R_2 is $(10 - 1.8) / 1.8 = 4.555$. Substituting the appropriate extreme values in (3) it must be $(4.75 - 7 \cdot 10^{-6} \cdot R1) / (1 + 4.555) < 0.32$; solving for R_1 yields $R1 > 425$ k Ω ; let us consider an additional 4% margin to take both the tolerance and the granularity of the R_1 and R_2 values into account, so that: $R1 > 425 \cdot 1.04 = 442$ k Ω . Choose $R1 = 442$ k Ω (E48 standard value) and, from the second of (2), $R2 = 442/4.555 = 97$ k Ω ; use 97.6 k Ω (E48 standard value).

Example 2 $V_{CC_G} = 10$ V, $V_{DVS1,2_Off} = -12$ mV.

In this case, V_{EN} must definitely be higher than the maximum value of V_{EN_Th} ($= 0.40$ V). From the second of (2), the nominal ratio of R_1 to R_2 is $(10 - 1.8) / 1.8 = 4.555$. Substituting the appropriate extreme values in (3) it must be $(4.25 - 13 \cdot 10^{-6} \cdot R1) / (1 + 4.555) > 0.4$; solving for R_1 yields $R1 < 156$ k Ω ; with 4% additional margin $R1 < 156/1.04 = 150$ k Ω . Choose $R1 = 147$ k Ω (E48 standard value) and, from the second of (2), $R2 = 147/4.555 = 32.3$ k Ω ; use 32.4 k Ω (E48 standard value).

Note: In both examples the gate drivers are disabled as V_{CC} falls below 9.75 V (nominal value), as the voltage on the EN pin falls 45 mV below V_{EN_On} .

6.1.3 Remote on/off control

Whichever configuration is used, since a voltage on the EN pin 45 mV below V_{EN_On} disables the gate drivers, any small-signal transistor can be used to pull down the EN pin and force the gate drivers into an off state.

Finally, it should be noted that during power-up, power-down, and under overload or short-circuit conditions, the gate drivers are shut down if the V_{CC} voltage is insufficient: $< V_{CCOff}$ in

case of pull-up resistor configuration, $< 0.975 \cdot V_{CC_G}$ in case of resistor divider configuration (the coefficient 0.975 depends on the hysteresis on the Enable pin threshold).

6.2 Drain voltage sensing

In the following explanations it is assumed that the reader is familiar with the LLC resonant half bridge topology and its waveforms, especially those on the secondary side with a center tap transformer winding for full wave rectification.

To understand the polarity and the level of the current flowing in the SR MOSFETs (or their body diodes, or diodes in parallel to the MOSFETs) the IC is provided with two pins, DVS1-2, able to sense the voltage level of the MOSFET drains.

Figure 7. Typical waveform seen on the drain voltage sensing pins

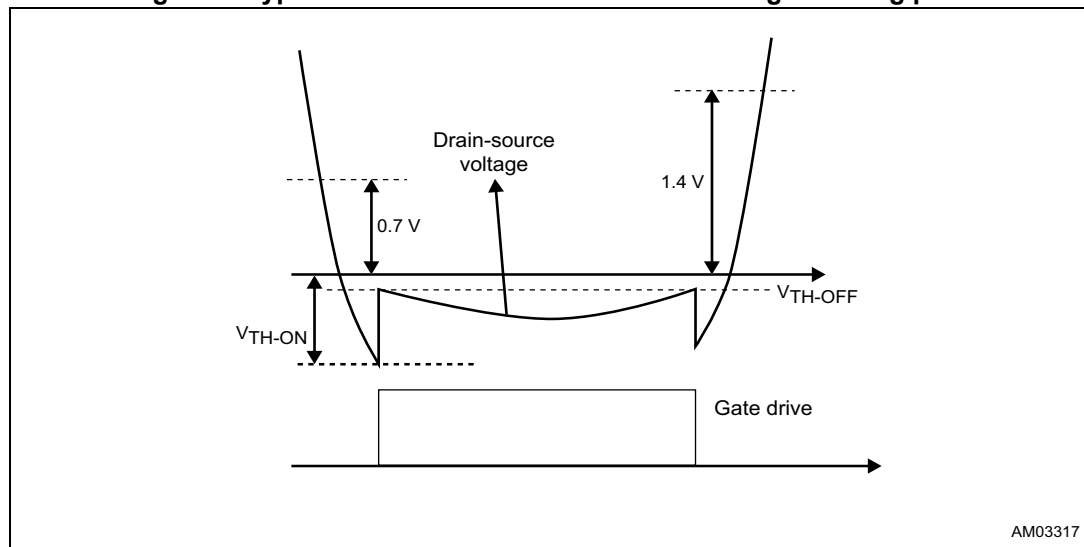

The logic that controls the driving of the two SR MOSFETs is based on two gate-driver state machines working in parallel in an interlocked way to avoid both gate drivers being switched on at the same time.

There are four significant drain voltage thresholds: the first one, $V_{DVS1,2_A}$ ($= 1.4\text{ V}$), sensitive to positive-going edges, arms the opposite gate driver (interlock function); the second, $V_{DVS1,2_PT}$ ($= 0.7\text{ V}$), sensitive to negative-going edges, provides a pre-trigger of the gate driver; the third is the (negative) threshold V_{TH_ON} that triggers the gate driver as the body diode of the SR MOSFET starts conducting; the fourth is the internal (negative) threshold $V_{DVS1,2_Off}$ where the SR MOSFET is switched off (selectable between -12 mV or -25 mV by properly biasing the EN pin).

The V_{DVS1_Off} and V_{DVS2_Off} thresholds are matched in order to have the same current turn-off level in both SR MOSFETs.

The value of the ON threshold V_{TH_ON} is affected by the external resistor in series to each DVS1-2 pin needed essentially to limit the current that might be injected into the pins when one SR MOSFET is off and the other SR MOSFET is conducting. In fact, on the one hand, when one MOSFET is off (and the other one is conducting), its drain-to-source voltage is slightly higher than twice the output voltage; if this exceeds the voltage rating of the internal clamp ($V_{CCZ} = 36\text{ V typ.}$), a series resistor R_D must limit the injected current below an appropriate value, lower than the maximum rating (25 mA) and taking the related power

dissipation into account. On the other hand, when current starts flowing into the body diode of one MOSFET (or in the diode in parallel with the MOSFET), the drain-to-source voltage is negative ($\cong -0.7$ V); when the voltage on pins DVS1,2 reaches the threshold $V_{DVS1,2_TH}$ (-0.2 V typ.), an internal current source $I_{DVS1,2_On}$ is activated; as this current exceeds $50 \mu\text{A}$, the gate of the MOSFET is turned on. Therefore, the actual triggering threshold can be determined by [Equation 6](#).

Equation 6

$$V_{TH-ON} = R_D \cdot I_{DVS1,2_On} + V_{DVS1,2_TH}$$

For instance, with $R_D = 2 \text{ k}\Omega$, the triggering threshold is located at $-(2 \text{ k}\Omega \cdot 50 \mu\text{A}) - 0.2 \text{ V} = -0.3 \text{ V}$.

To avoid false triggering of the gate driver, a debounce delay T_{PD_On} ($= 250 \text{ ns}$) is used after sourcing $I_{DS1,2_On}$ (i.e. the current sourced by the pin must exceed $50 \mu\text{A}$ for more than 250 ns before the gate driver is turned on). This delay is not critical for the converter's efficiency because the initial current is close to zero or anyway much lower than the peak value.

Once the SR MOSFET has been switched on, its drain-to-source voltage drops to a value given by the flowing current times the MOSFET $R_{DS(on)}$. Again, since the initial current is low, the voltage drop across the $R_{DS(on)}$ may exceed the turn-off threshold $V_{DVS1,2_Off}$, and determine an improper turn-off. To prevent this, the state machine enables the turn-off comparator referenced to $V_{DVS1,2_Off}$ only in the second half of the conduction cycle, based on the information of the duration of the previous cycle. In the first half of the conduction cycle only an additional comparator, referenced to zero, is active to prevent the current of the SR MOSFET from reversing, which would impair the operation of the LLC converter.

Once the threshold $V_{DVS1,2_Off}$ is crossed (in the second half of the conduction cycle) and the GATE is turned off, the current again flows through the body diode causing the drain-to-source voltage to have a negative jump, going again below V_{TH-ON} . The interlock logic, however, prevents a false turn-on. It is worth pointing out that, due to the fact that each MOSFET is turned on after its body diode starts conducting, the ON transition happens with the drain-source voltage equal to the body diode forward drop; therefore there is neither a Miller effect nor switching losses at MOSFET turn-on. Also at turn-off the switching losses are not present, in fact, the current is always flowing from source to drain and, when the MOSFET is switched off, it goes on flowing through the body diode (or the external diode in parallel to the MOSFET).

Unlike at turn-on, the turn-off speed is critical to avoid current reversal on the secondary side, especially when the converter operates above the resonance frequency, where the current flowing through the MOSFET exhibits a very steep edge while decreasing down to zero: the turn-off propagation T_{PD_Off} delay has a maximum value of 60 ns .

The interlock logic, in addition to checking for consistent secondary voltage waveforms (one MOSFET can be turned on only if the other one has a positive drain-to-source voltage $> V_{DVS1,2_A}$) to prevent simultaneous conduction, allows only one switching per cycle: after one gate driver has been turned off, it cannot be turned on again before the other gate drive has had its own on/off cycle.

The IC logic also prevents unbalanced current in the two SR MOSFETs: if one SR MOSFET fails to turn on in one cycle, the other SR MOSFET is also not turned on in the next cycle.

Figure 8. Typical connection of the SRK2000A to the SR MOSFET

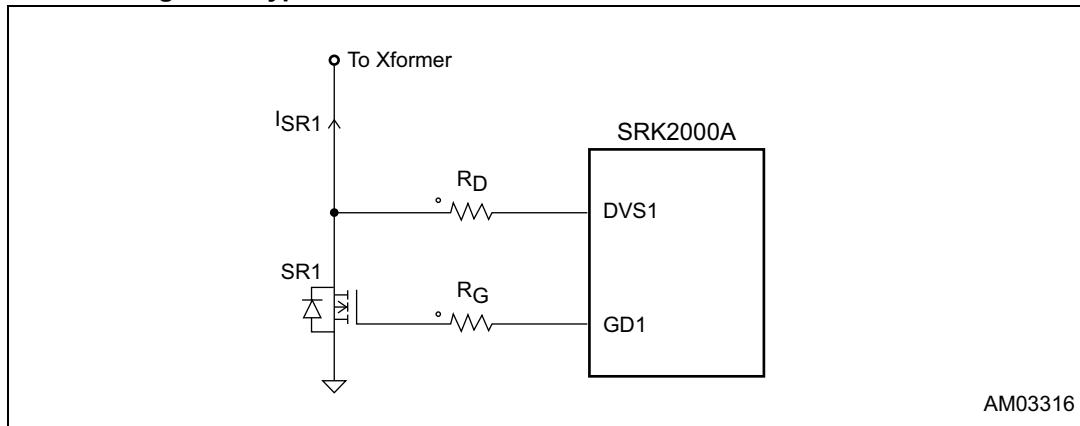

6.3 Gate driving

The IC is provided with two high current gate drive outputs (1 A source and 3.5 A sink), each capable of driving one or more N-channel Power MOSFETs. Thanks to the programmable gate drive UVLO, it is possible to drive both - the standard MOSFETs and logic level MOSFETs.

The high-level voltage provided by the driver is clamped at $V_{GDclamp}$ (= 12 V) to avoid excessive voltage levels on the gate in case the device is supplied with a high V_{CC} .

The two gate drivers have a pull-down capability that ensures the SR MOSFETs cannot be spuriously turned on even at low V_{CC} : in fact, the drivers have a 1 V (typ.) UVLO saturation level at V_{CC} below the turn-on threshold.

6.4 Intelligent automatic sleep mode

A unique feature of this IC is its intelligent automatic sleep mode. The logic circuitry is able to detect a light load condition for the converter and stop gate driving, also reducing the IC's quiescent consumption. This improves converter efficiency at light load, where the power losses on the rectification body diodes (or external diodes in parallel to the MOSFETs) go lower than the power losses in the MOSFETs and those related to their driving.

The IC is also able to detect an increase of the converter's load and automatically restart gate driving.

The algorithm used by the intelligent automatic sleep mode is based on a dual time measurement system. The duration of a switching cycle of an SR MOSFET (that is one half of the resonant converter switching period) is measured using a combination of the negative-going edge of the drain-to-source voltage falling below $V_{DVS1,2_PT}$ and the positive-going edge exceeding $V_{DVS1,2_A}$; the duration of the SR MOSFET conduction is measured from the moment its body diode starts conducting (drain-to-source voltage falling below V_{TH-ON}) to the moment the gate drive is turned off (in case the device is operating) or the moment the body diode ceases to conduct (drain-to-source voltage going over V_{TH-ON}). While at full load the SR MOSFET conduction time occupies almost 100% of the switching cycle, as the load is reduced, the conduction time is reduced and as it falls below 40% (D_{OFF}) of the SR MOSFET switching cycle the device enters sleep mode. To prevent

erroneous decisions, the sleep mode condition must be confirmed on at least one of the two sections for 16 consecutive switching cycles of the resonant converter.

Once in sleep mode, SR MOSFET gate driving is re-enabled when the conduction time of the body diode (or the external diodes in parallel to the MOSFET) exceeds 60% (D_{ON}) of the switching cycles. Also in this case the decision is made considering the measurement on 8 consecutive switching cycles (i.e. 8 consecutive cycles for each SR MOSFET of the center tap). Furthermore, after each sleep mode entering/exiting transition, the timing is ignored for a certain number of cycles, to let the resulting transient in the output current fade out. The number of ignored resonant converter switching cycles is 128 after entering the sleep mode and 256 after exiting the sleep mode. If by the end of the ignored cycles the condition to enter or exit the sleep mode is already met for the required number of cycles, the state will be changed immediately; otherwise the controller (after the ignored cycles) will wait until that condition is satisfied.

6.5 Protection against current reversal

The IC provides protection against SR MOSFET current reversal. If a current reversal condition is detected for two consecutive switching cycles, the IC goes into sleep mode, avoiding the turn-on of the SR MOSFETs until a safe condition is restored.

6.6 Layout guidelines

The IC is designed with two grounds, SGND and PGND.

SGND is used as the ground reference for all the internal high-precision analog blocks, while PGND is the ground reference for all the noisy digital blocks, as well as the current return for the gate drivers. In addition, it is also the ground for the ESD protection circuits. SGND is protected by ESD events versus PGND through two anti-parallel diodes.

When laying out the PCB, make sure to keep the source terminals of both SR MOSFETs as close as possible to one another and to route the trace that goes to PGND separately from the load current return path. This trace should be as short as possible and be as close to the physical source terminals as possible. A layout that is as geometrically symmetrical as possible helps the circuit to operate in the most electrically symmetrical way as possible. SGND should be directly connected to PGND using a path as short as possible (under the device body).

Also drain voltage sensing should be performed as physically close to the drain terminals as possible: any stray inductance crossed by the load current that is in the drain-to-source voltage sensing circuit may significantly alter the current reading, leading to a premature turn-off of the SR MOSFET. It is worth mentioning that, especially in higher power applications or at higher operating frequencies, even the stray inductance of the internal wire bonding can be detrimental. In this case, a cautious selection of the SR MOSFET package is required.

The use of bypass capacitors between V_{CC} and both SGND and PGND is recommended. They should be low-ESR, low-ESL types and located as close to the IC pins as possible. Sometimes a series resistor (in the tens) between the converter's output voltage and the V_{CC} pin, forming an RC filter along with the bypass capacitor, is useful in order to get a cleaner V_{CC} voltage.

7 Package information

In order to meet environmental requirements, ST offers these devices in different grades of ECOPACK® packages, depending on their level of environmental compliance. ECOPACK specifications, grade definitions and product status are available at: www.st.com. ECOPACK is an ST trademark.

7.1 SO-8 package information

Figure 9. SO-8 package outline

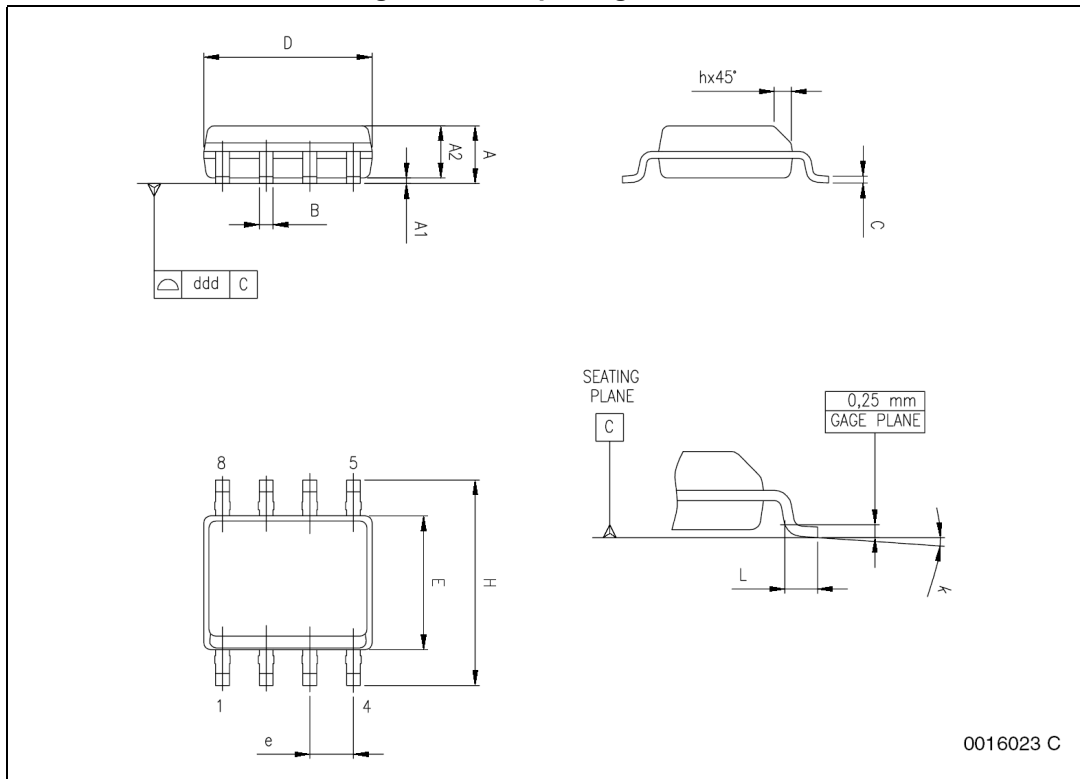

0016023 C

Table 6. SO-8 package mechanical data

Symbol	Dimensions (mm)			Dimensions (inch)		
	Min.	Typ.	Max.	Min.	Typ.	Max.
A	1.35	-	1.75	0.053	-	0.069
A1	0.10	-	0.25	0.004	-	0.010
A2	1.10	-	1.65	0.043	-	0.065
B	0.33	-	0.51	0.013	-	0.020
C	0.19	-	0.25	0.007	-	0.010
D ⁽¹⁾	4.80	-	5.00	0.189	-	0.197
E	3.80	-	4.00	0.15	-	0.157
e	-	1.27	-	-	0.050	-
H	5.80	-	6.20	0.228	-	0.244
h	0.25	-	0.50	0.010	-	0.020
L	0.40	-	1.27	0.016	-	0.050
k	0° (min.), 8° (max.)					
ddd	-	-	0.10	-	-	0.004

1. D dimensions do not include mold flash, protrusions or gate burrs. Mold flash, protrusions or gate burrs should not exceed 0.15 mm (0.006 inch) in total (both sides).



8 Revision history

Table 7. Document revision history

Date	Revision	Changes
18-Oct-2013	1	Initial release.
13-Dec-2013	2	Updated <i>Table 1 on page 1</i> (removed "D" from order codes). Minor modifications throughout document.
04-May-2017	3	Updated text in Section 6.4 on page 14 . Minor modifications throughout document.

IMPORTANT NOTICE – PLEASE READ CAREFULLY

STMicroelectronics NV and its subsidiaries ("ST") reserve the right to make changes, corrections, enhancements, modifications, and improvements to ST products and/or to this document at any time without notice. Purchasers should obtain the latest relevant information on ST products before placing orders. ST products are sold pursuant to ST's terms and conditions of sale in place at the time of order acknowledgement.

Purchasers are solely responsible for the choice, selection, and use of ST products and ST assumes no liability for application assistance or the design of Purchasers' products.

No license, express or implied, to any intellectual property right is granted by ST herein.

Resale of ST products with provisions different from the information set forth herein shall void any warranty granted by ST for such product.

ST and the ST logo are trademarks of ST. All other product or service names are the property of their respective owners.

Information in this document supersedes and replaces information previously supplied in any prior versions of this document.

© 2017 STMicroelectronics – All rights reserved

