

NOTES:

1. ELECTRICAL:
 - A. IMPEDANCE: 50 OHM
 - B. DIELECTRIC WITHSTANDING VOLTAGE: 1500 VRMS. MIN.
2. MECHANICAL:
 - A. DURABILITY: 500 CYCLES MIN.
 - B. TEMPERATURE RANGE: -65°C TO +165°C
3. CRIMPED FERRULE
 - HEX CRIMP SIZE .213"
4. CONTACT PIN TO SOLDER
 - HEX: CRIMP SIZE .068"

REV.	DATE	ECR NO.	DESCRIPTION
NC	04/05/03	XXXXXX	UPDATED DRAWING FORMAT
A	03/19/12	2291	ADDED NOTES

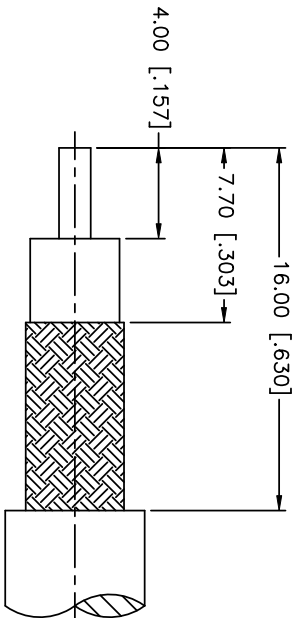

RECOMMENDED
CABLE STRIPPING DIM'S

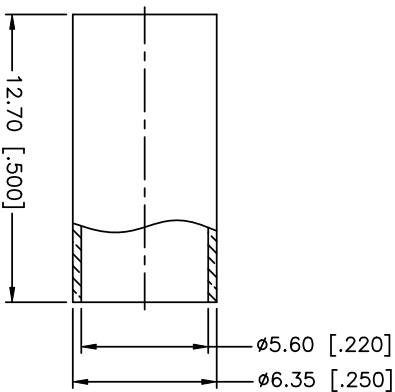
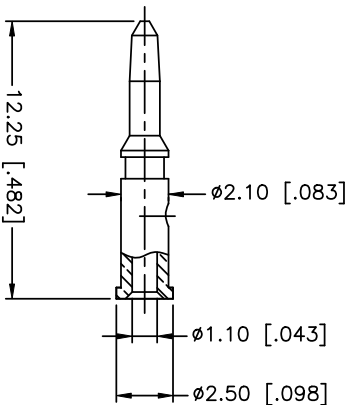
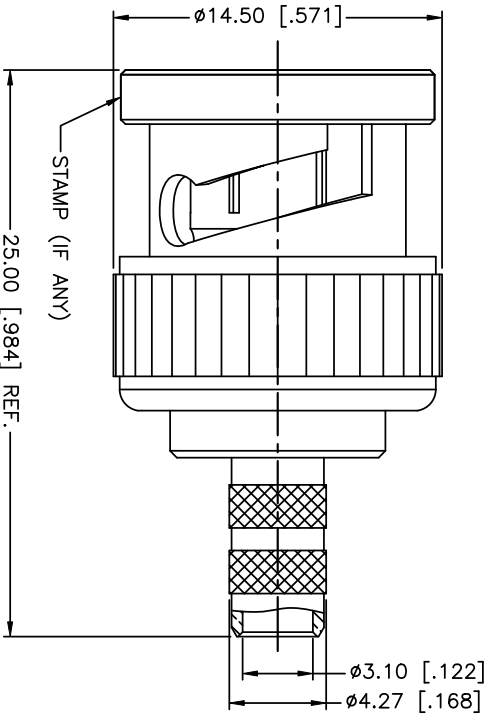

QTY	FINISH	MATERIAL	DESCRIPTION
1	NICKEL	BRASS	FERRULE
1	GOLD	BRASS	CONTACT PIN
1	NICKEL	ZINC DIE-CAST	SHELL
1	RED	RUBBER	GASKET
1	NICKEL	BRASS	RETAINER RING
1	NICKEL	SKS	SPRING
1	NICKEL	BRASS	WASHER
1	NATURAL	DELFIN	INSULATOR
1	NICKEL	BRASS	BODY

APPROVALS	DATE
DRAWN T.DENG	03/19/12
CHECKED	
ISSUED	
SHEET 1 OF 1	

DO NOT SCALE DRAWING	CAD FILE	DWG. NO.	REV. A	SIZE A	SCALE NA
	C:/CONNEX/112514.DWG	112514.DWG			

PART DESCRIPTION	PART NO.
Amphenol Connex BNC CRIMP PLUG (FOR RG-55/U, 142A/U, 223/U, 400/U)	112514