

REV.	DATE	DESCRIPTION
C	04/08/01	ADD NOTES AND MOUNTING HOLE
D	04/31/03	UPDATE DRAWING FORMAT

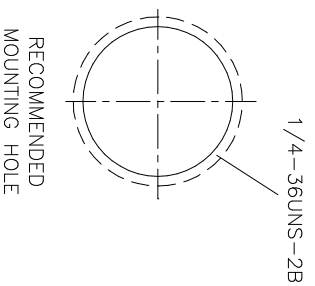
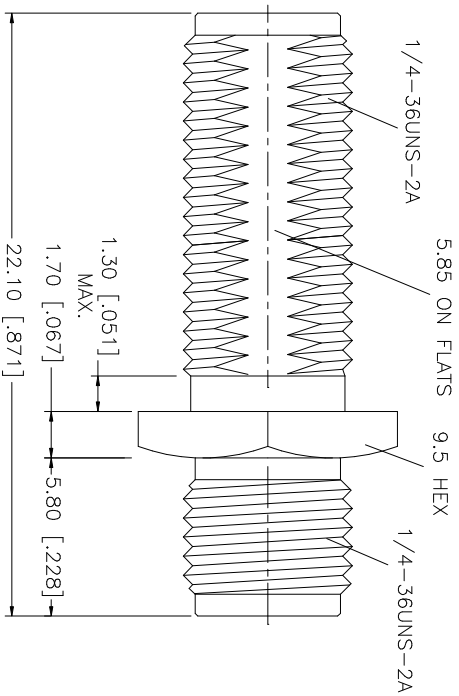
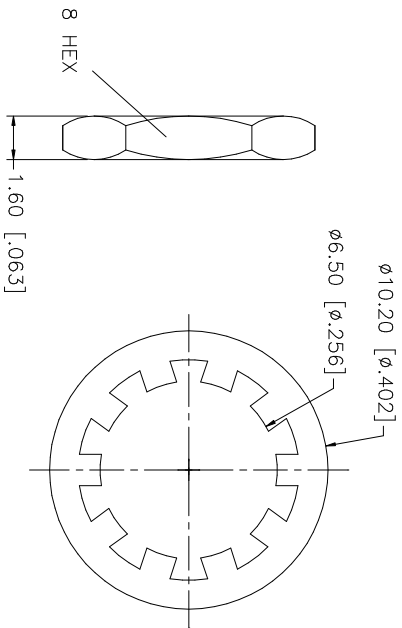
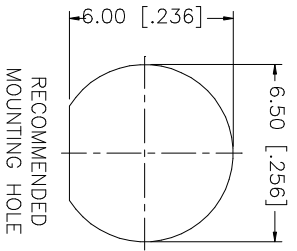

- NOTES:
- MAX. PANEL THICKNESS = 6.5mm
MIN. PANEL THICKNESS = 2mm

UNLESS OTHERWISE SPECIFIED DIMENSIONS ARE IN MILLIMETERS DIMENSIONS IN PARENTHESES ARE IN INCHES AND FOR CUSTOMER REFERENCE ONLY.	UNLESS OTHERWISE SPECIFIED TOLERANCES FOR MILLIMETERS ARE:	UNLESS OTHERWISE SPECIFIED TOLERANCES FOR INCHES ARE:	APPROVALS	DATE	PART DESCRIPTION	
8			DRAWN	G.R.S.	04/31/03	<p>Amphenol Connex</p> <p>SMA BULKHEAD FEMALE TO FEMALE ADAPTOR</p> <p>132170</p>
7			CHECKED			
6	HEX NUT	BRASS	ISSUED			
5	LOCK WASHER	BRASS	SHEET	1 OF 1		
4	CONTACT PIN	BER. COPPER				
3	INSULATOR	TEFLON				
2	BODY	BRASS				
1	DESCRIPTION	MATERIAL	FINISH	QTY	DO NOT SCALE DRAWING	
			CAD FILE	C:/132/132170.DWG	DWG. NO.	132170.DWG
					REV.	D
					SIZE	A
					SCALE	NA