

4 TERMINAL LOW DROPOUT VOLTAGE REGULATOR

The KIA78R × × series are Low Dropout Voltage Regulator suitable for various electronic equipments. It provides constant voltage power source with TO-220IS-4 terminal surface mount type PKG.

The Regulator has multi function such as over current protection, overheat protection and ON/OFF control.

FEATURES

- 1.0A Output Low Dropout Voltage Regulator.
- Built in ON/OFF Control Terminal.
- Built in Over Current Protection, Over Heat Protection Function.

LINE UP

| ITEM | OUTPUT VOLTAGE (Typ.) | UNIT |
|------------|-----------------------|------|
| KIA78R05PI | 5 | V |
| KIA78R06PI | 6 | |
| KIA78R08PI | 8 | |
| KIA78R09PI | 9 | |
| KIA78R10PI | 10 | |
| KIA78R12PI | 12 | |
| KIA78R15PI | 15 | |
| KIA78R25PI | 2.5 | |
| KIA78R33PI | 3.3 | |
| KIA78R35PI | 3.5 | |

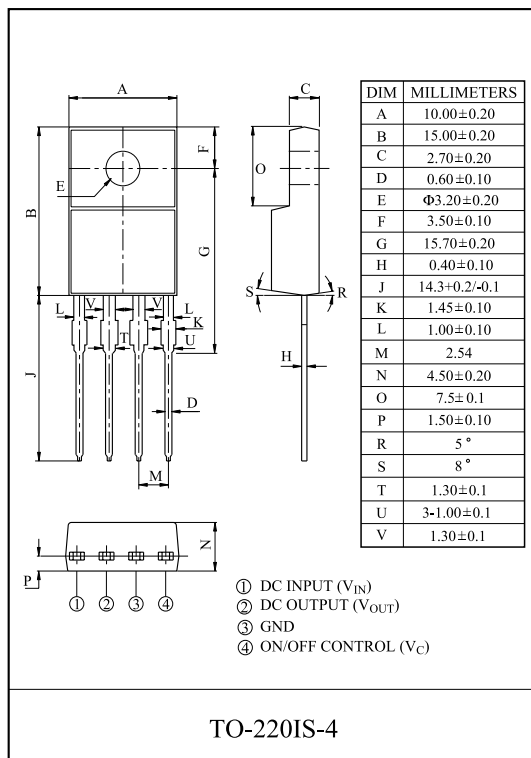

MAXIMUM RATINGS (Ta=25 °C)

| CHARACTERISTIC | SYMBOL | RATING | UNIT | REMARK |
|--------------------------------|---------------------|---------|------|-------------------|
| Input Voltage | V _{IN} | 35 | V | - |
| ON/OFF Control Voltage | V _C | 35 | V | - |
| Output Current | I _O | 1 | A | - |
| Power Dissipation 1 | P _{D1} | 1.5 | W | No Heatsink |
| Power Dissipation 2 | P _{D2} | 15 | W | Infinite Heatsink |
| Operating Junction Temperature | T _{J(opr)} | -40 150 | | - |
| Storage Temperature | T _{stg} | -45 150 | | - |
| Soldering Temperature (10sec) | T _{sol} | 260 | | - |

KIA78R05PI~KIA78R35PI

ELECTRICAL CHARACTERISTICS

(Unless otherwise specified, $I_O=0.5A$, $T_a=25$, Note1.)

| CHARACTERISTIC | | SYMBOL | CONDITIONS | MIN. | TYP. | MAX. | UNIT |
|---|------------|--------------|----------------------------------|-------|------------|------------|---------|
| Output Voltage | KIA78R05PI | V_O | - | 4.88 | 5.0 | 5.12 | V |
| | KIA78R06PI | | - | 5.85 | 6.0 | 6.15 | |
| | KIA78R08PI | | - | 7.80 | 8.0 | 8.2 | |
| | KIA78R09PI | | - | 8.78 | 9.0 | 9.22 | |
| | KIA78R10PI | | - | 9.75 | 10.0 | 10.25 | |
| | KIA78R12PI | | - | 11.70 | 12.0 | 12.30 | |
| | KIA78R15PI | | - | 14.70 | 15.0 | 15.30 | |
| | KIA78R25PI | | - | 2.438 | 2.50 | 2.562 | |
| | KIA78R33PI | | - | 3.220 | 3.30 | 3.380 | |
| | KIA78R35PI | | - | 3.413 | 3.50 | 3.587 | |
| Load Regulation | | Reg Load | 5mA I_{OUT} 1A | - | 0.1 | 2.0 | % |
| Line Regulation | | Reg Line | (Note 2) | - | 0.5 | 2.5 | % |
| Temperature Coefficient of Output Voltage | | $T_C V_O$ | $T_j=0$ 125 | - | ± 0.02 | ± 0.05 | %/ |
| Ripple Rejection | | $R \cdot R$ | - | 45 | 55 | - | dB |
| Drop Out Voltage | | V_D | $I_O=1A$, $V_{IN}=0.95 V_{OUT}$ | - | - | 0.5 | V |
| Output ON state for control Voltage | | $V_{C(ON)}$ | - | 2.0 | - | - | V |
| Output ON state for control Current | | $I_{C(ON)}$ | $V_C=2.7V$ | - | - | 20 | μA |
| Output OFF state for control Voltage | | $V_{C(OFF)}$ | - | - | - | 0.8 | V |
| Output OFF state for control Current | | $I_{C(OFF)}$ | $V_C=0.4V$ | - | - | -0.4 | mA |
| Quiescent Current | | I_Q | $I_O=0$ | - | - | 10 | mA |

Note1) V_{IN} of KIA78R05=7V

- " KIA78R06=8V
- " KIA78R08=10V
- " KIA78R09=15V
- " KIA78R10=16V
- " KIA78R12=18V
- " KIA78R15=21V
- " KIA78R25=4.2V
- " KIA78R33=5.0V
- " KIA78R35=5.2V

Note2) V_{IN} of KIA78R05=6~12V

- " KIA78R06=7~15V
- " KIA78R08=9~25V
- " KIA78R09=10~25V
- " KIA78R10=11~26V
- " KIA78R12=13~29V
- " KIA78R15=16~32V
- " KIA78R25=3.2~10V
- " KIA78R33=4.0~10V
- " KIA78R35=4.2~10V

KIA78R05PI~KIA78R35PI

BLOCK DIAGRAM

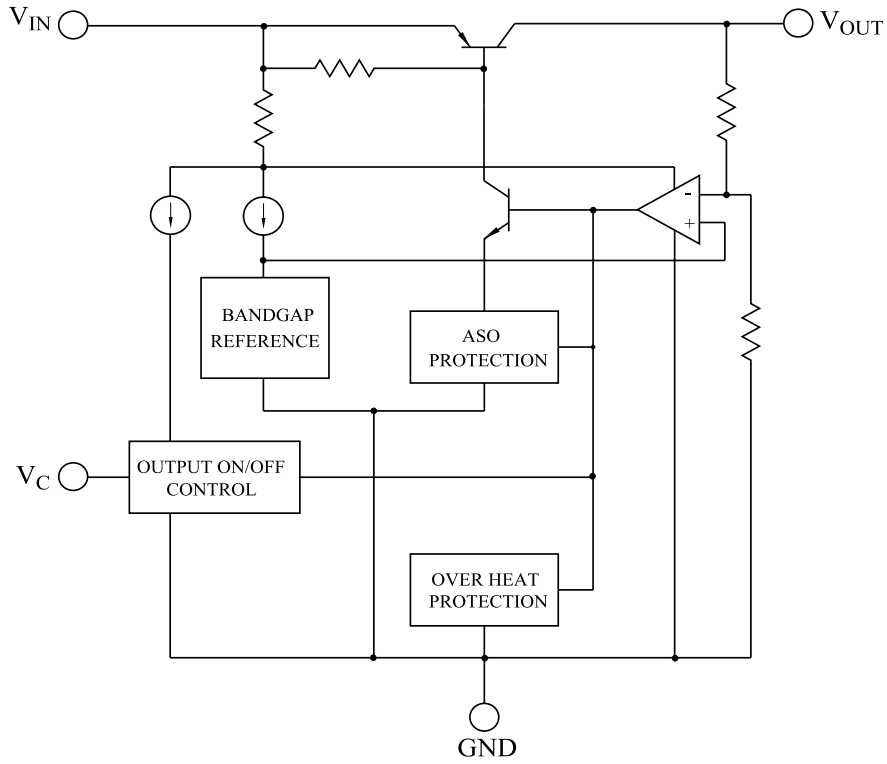

KIA78R05PI~KIA78R35PI

Fig. 1 Standard Test Circuit

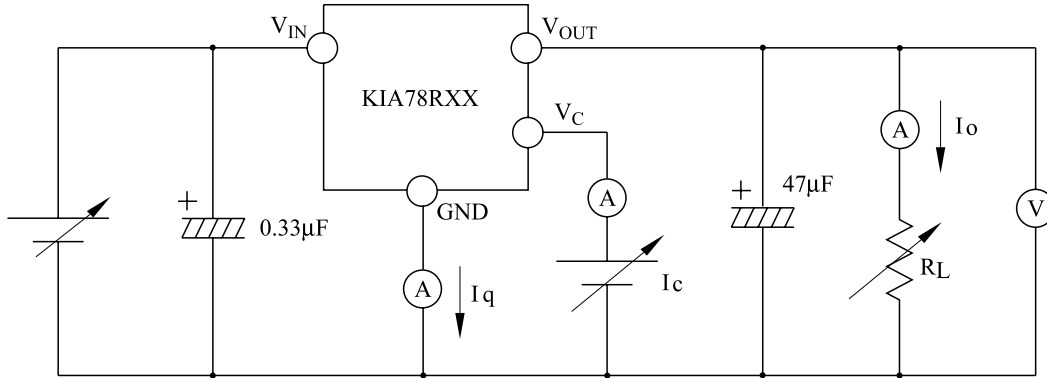

Fig. 2 Ripple Rejection Test Circuit

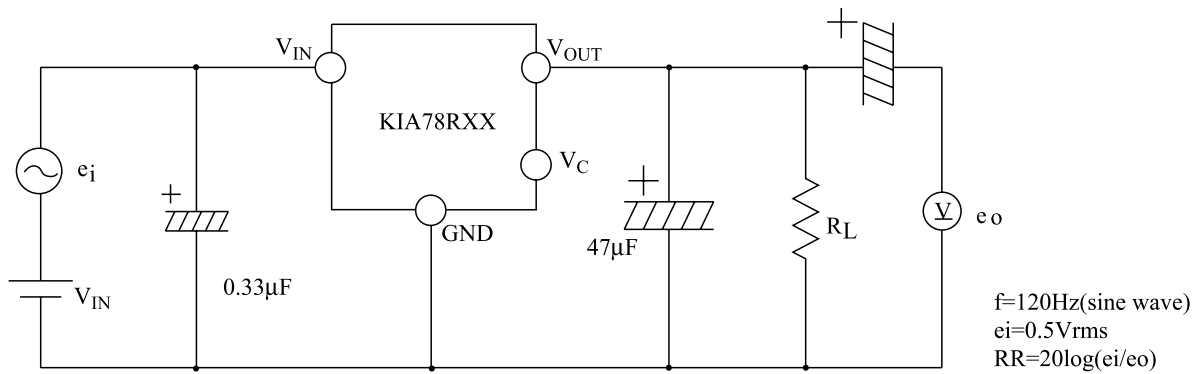
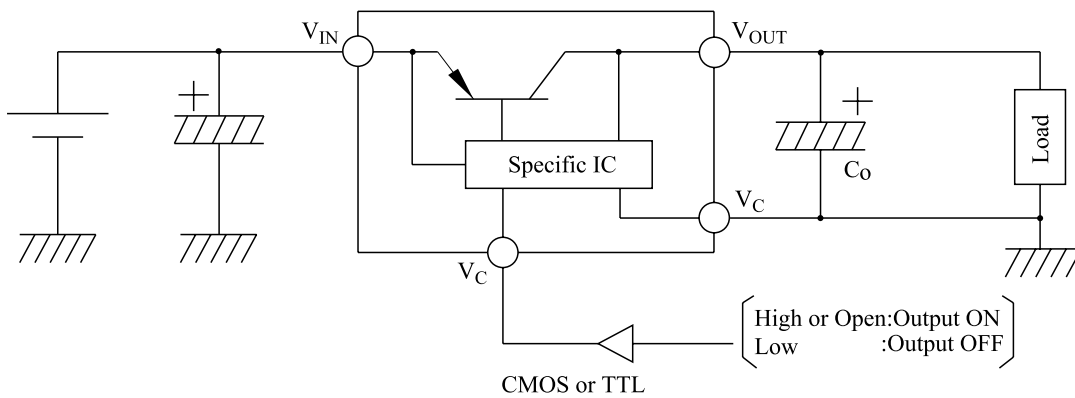

Fig. 3 Application Circuit for Standard



KIA78R05PI~KIA78R35PI

Fig.4 $P_D - T_a$ (PI-Type : TO-220IS-4)

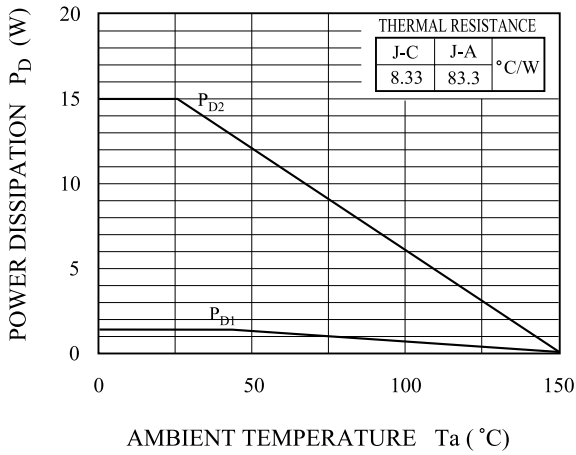

Fig. 5 $V_{OUT} - I_{OUT}$

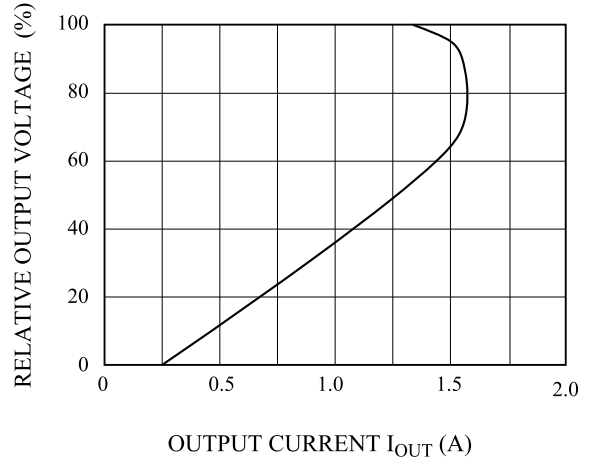

Fig. 6 $\Delta V_O - T_j$

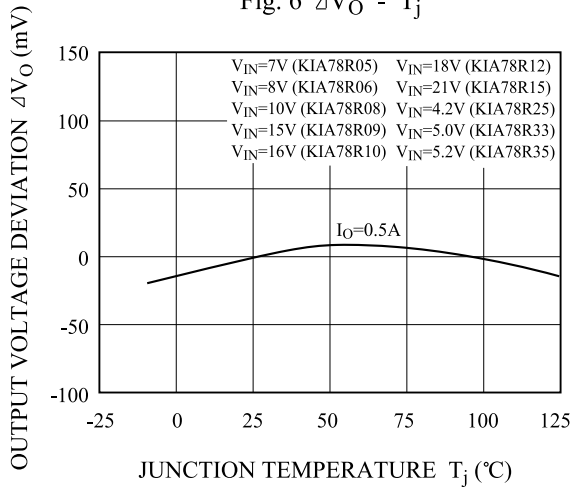

Fig. 7 $V_D - T_j$

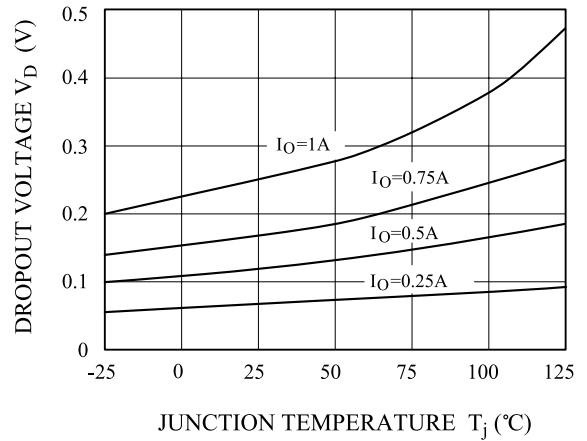

Fig. 8 $I_q - T_j$

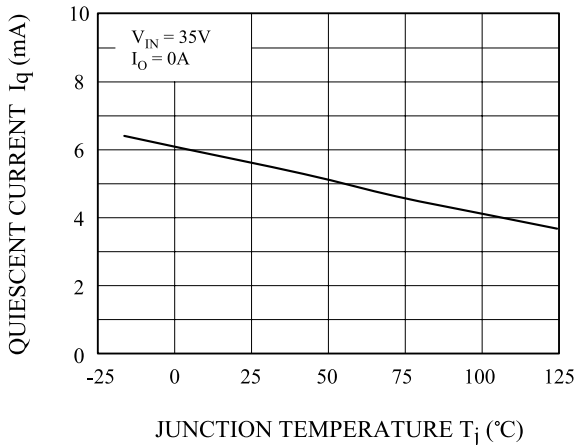
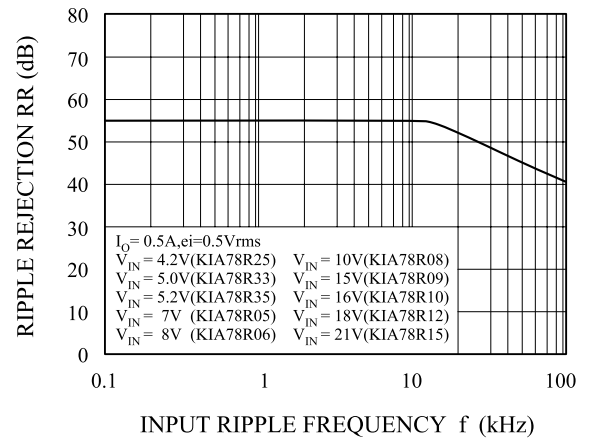

Fig. 9 R.R - f



KIA78R05PI~KIA78R35PI

Fig. 10 R.R - I_{OUT}

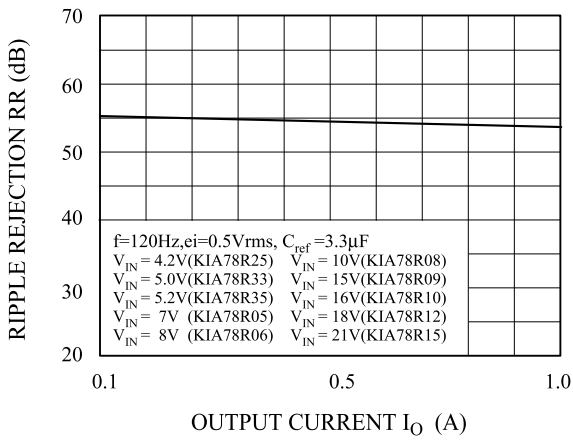

Fig. 11 V_{OUT} - V_{IN} (KIA78R05)

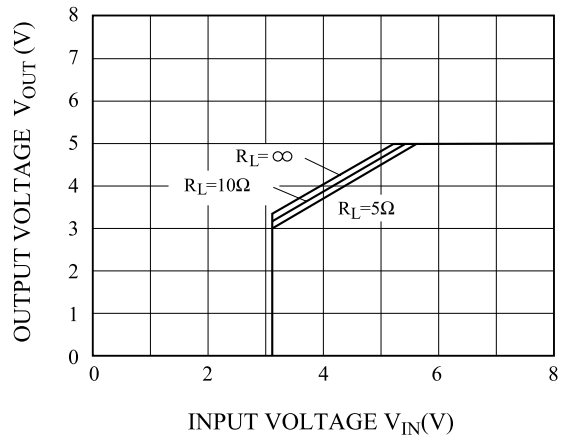

Fig. 12 V_{OUT} - V_{IN} (KIA78R06)

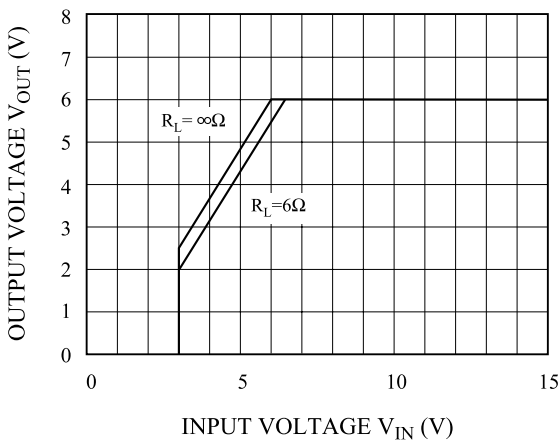

Fig. 13 V_{OUT} - V_{IN} (KIA78R08)

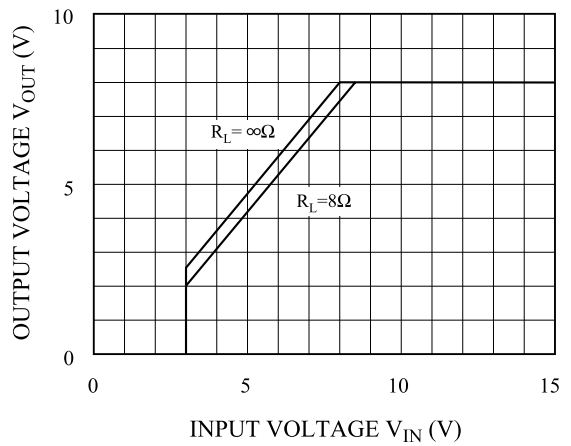

Fig. 14 V_{OUT} - V_{IN} (KIA78R09)

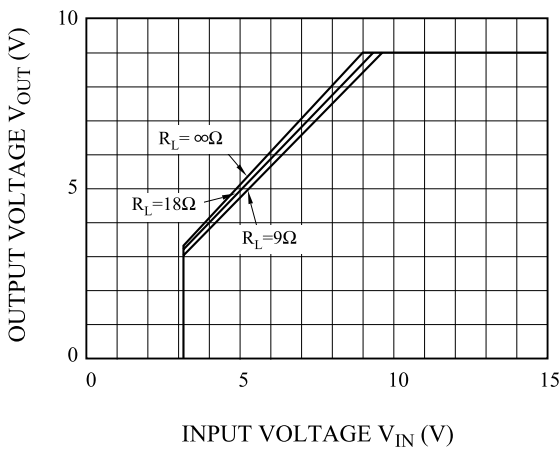
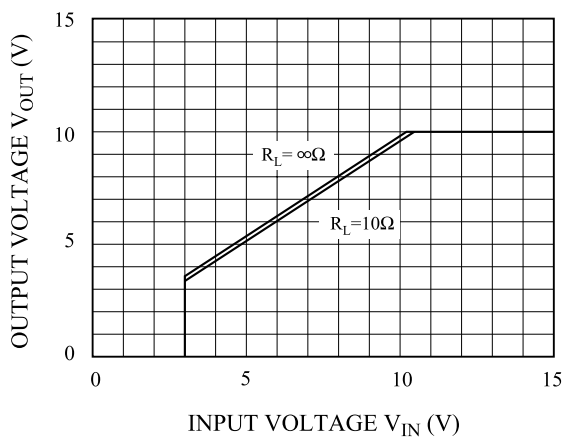

Fig. 15 V_{OUT} - V_{IN} (KIA78R10)



KIA78R05PI~KIA78R35PI

Fig. 16 $V_{OUT} - V_{IN}$ (KIA78R12)

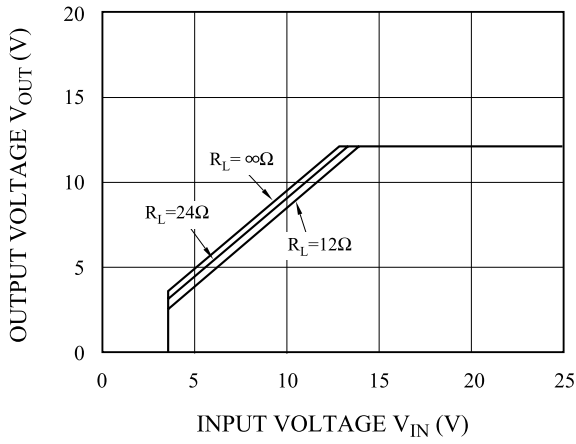

Fig. 17 $V_{OUT} - V_{IN}$ (KIA78R15)

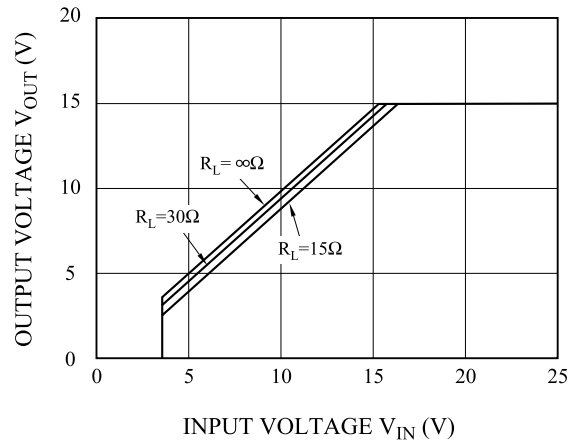

Fig. 18 $I_{BIAS} - V_{IN}$ (KIA78R05)

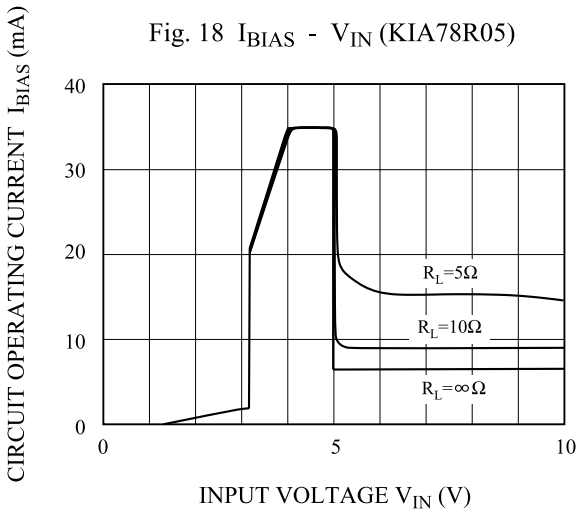

Fig. 19 $I_{BIAS} - V_{IN}$ (KIA78R06)

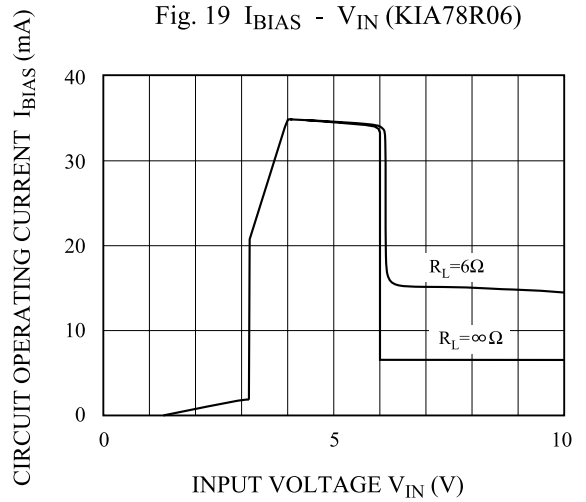

Fig. 20 $I_{BIAS} - V_{IN}$ (KIA78R08)

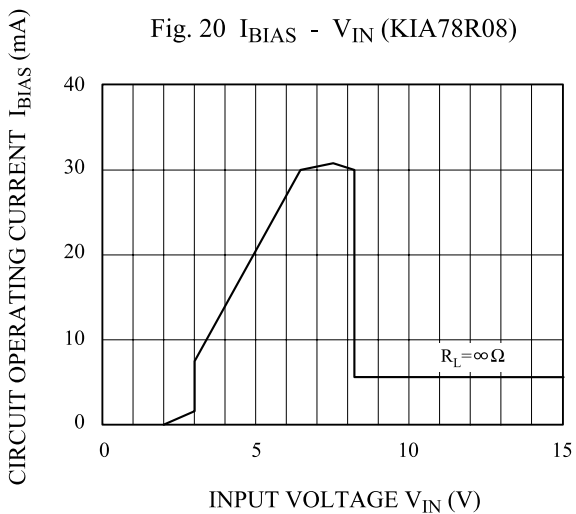
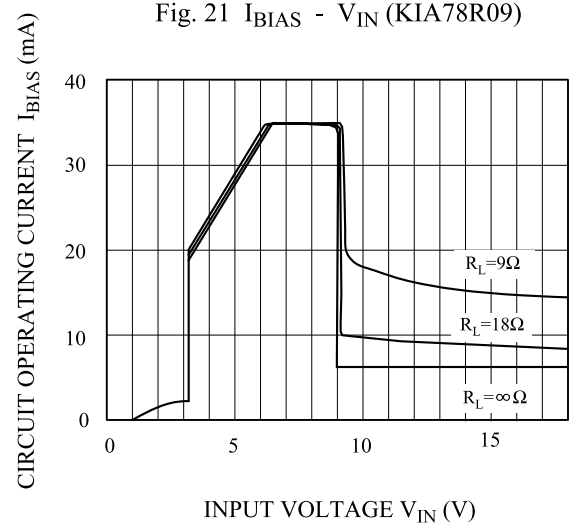

Fig. 21 $I_{BIAS} - V_{IN}$ (KIA78R09)



KIA78R05PI~KIA78R35PI

Fig. 22 $I_{BIAS} - V_{IN}$ (KIA78R10)

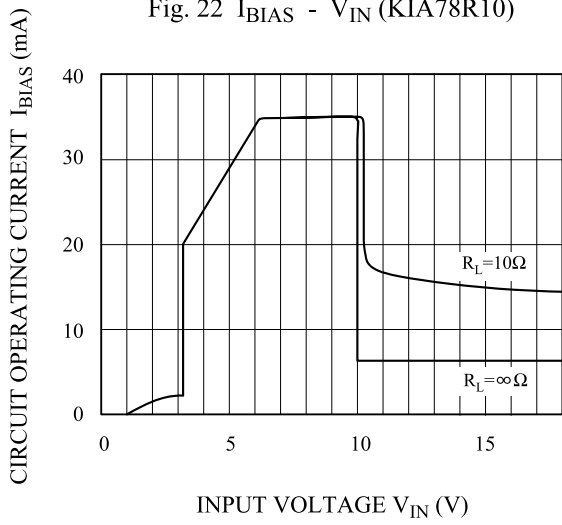

Fig. 23 $I_{BIAS} - V_{IN}$ (KIA78R12)

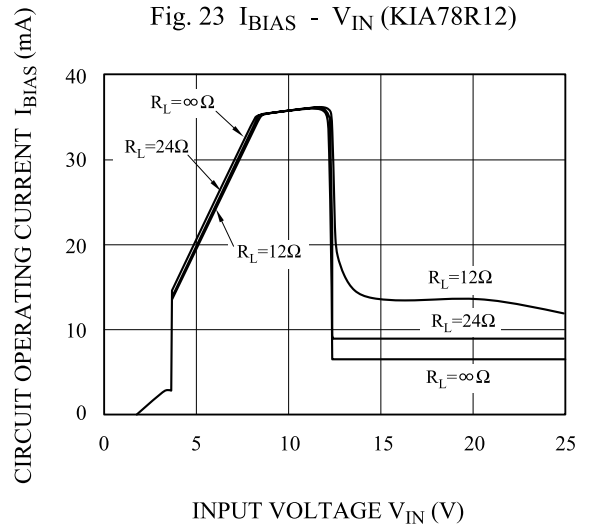

Fig. 24 $I_{BIAS} - V_{IN}$ (KIA78R15)

