

FCI CONFIDENTIAL

This document is the property of and embodies CONFIDENTIAL and PROPRIETARY information of FCI. No part of the information shown on this document may be used in any way or disclosed to others without the written consent of FCI.
Copyright FCI.

PRODUCT NUMBER
67008-001(LF)

WHEN NEEDED, SUFFIX LETTER "LF" INDICATES THE PRODUCT IS RoHS COMPLIANT, SEE NOTE 3

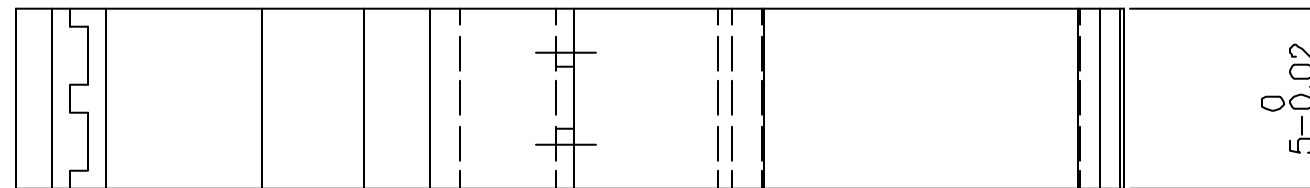
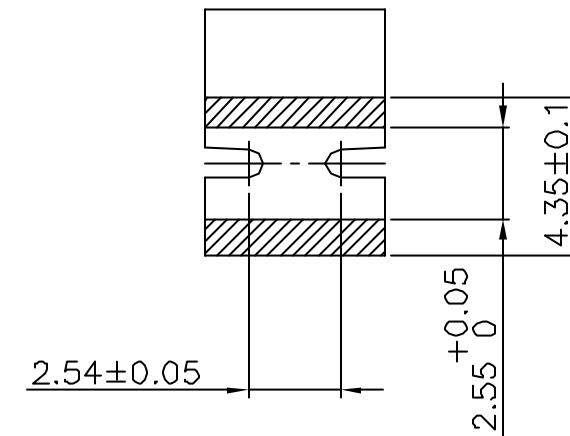
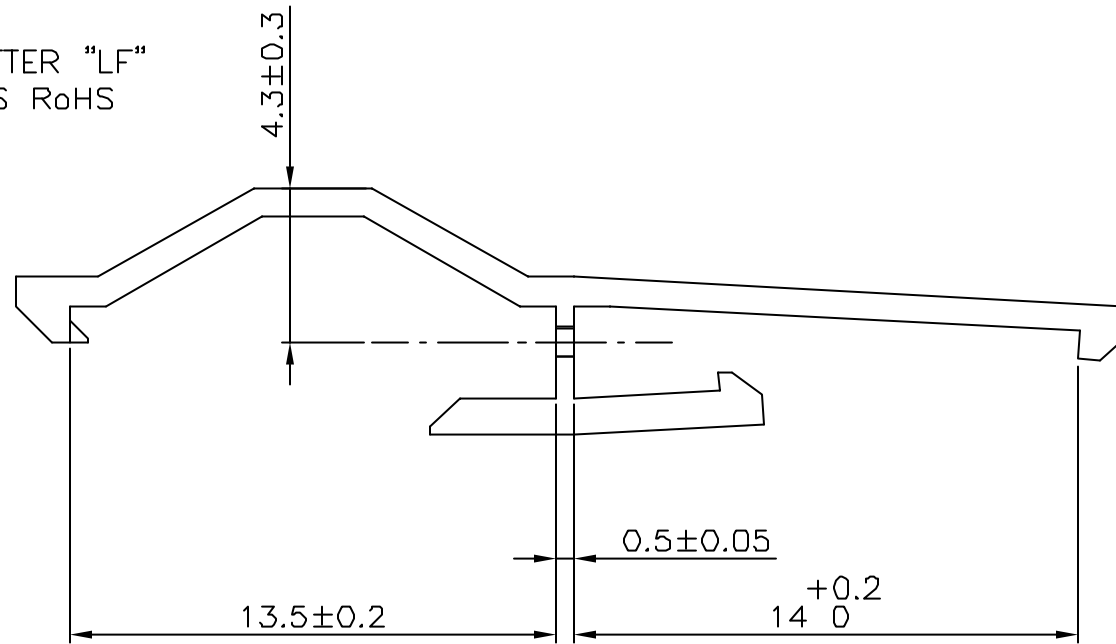

NOTES:

- 1- MATERIAL LATCH: NORYL UL 94-V1
- 2- THIS LATCH IS INTENDED FOR USSE IN COMBINATION WITH SINGLE ROW MINI LATCH HOUSING P/N 65039.
- 3 - RoHS COMPATIBLE PRODUCT SPECIFICATIONS
 - a - LABELING:
 - MEETS PACKAGING SPECS AS PER GS-14-920
 - b - LEGAL STATEMENT: SEE GS-22-008

THE PRODUCT IS NOT INTENDED TO BE EXPOSED TO A MANUFACTURING SOLDER PROCESS.

mat'l. code		surface		tolerance		projection		product family	
SEE NOTE		ISO 1302		ISO 406 ISO 1101				BERGCON	
ltr	ecn no	dr	date	tolerances unless otherwise specified		mm		title	
E	F05-0286	DLE	05.11.07	angles		mm		LATCH	
F	F06-0218	DLE	06.07.11	linear		scale 5:1		FLYING CONNECTION S.R	
		dr	D LEGRAND	05.08.17				dwg no	
		engr	P NIZZI	05.08.17				sheet 1 of 1	
		chr	D LE	05.08.17				size	
		appd	P NZ	05.08.117				A3	
sheet index		revision sheet						type	
								CUSTOMER Drawing	