



»» Features

- Miniature 12A 125VAC, 10A 250VAC/30VDC PCB Relay.
- UL/CUL, TUV, VDE approved.
- 450mW and 200mW coil are available.
- High CTI 250 material or product comply with IEC 60335-1 are available.
- Complies with RoHS-Directive 2011/65/EU.
- Optional for halogen free version.
- Optional for explosion-proof version.

»» Type List

◆ Standard type

Terminal style	Contact form	Insulation system	Designation (provided with)		
			Flux tight	Sealed type	Sealed type washable
PCB terminal	1A (SPNO)	-----	307-1AH-C	307-1AH-V	307-1AH-S
		F	307-1AH-F-C	307-1AH-F-V	307-1AH-F-S

◆ High power type

PCB terminal	1A (SPNO)	-----	307H-1AC-C	307H-1AC-V	307H-1AC-S
		F	307H-1AC-F-C	307H-1AC-F-V	307H-1AC-F-S

»» Ordering Information

307 - 1A H - - C
 1 2 3 4 5 6 7 8

- | | |
|------------------------------------|---|
| 1. 307 -- Basic series designation | 6. Blank -- Standard type |
| 2. Blank -- Standard type | F -- Class F |
| H -- High power type | 7. C -- Flux tight |
| 3. Blank -- Standard type | V -- Sealed type |
| N -- High sensitivity type | S -- Sealed type washable |
| 4. 1A -- Single pole normally open | 8. <input type="checkbox"/> -- Coil voltage (please refer to the coil rating data for the availability) |
| 5. C -- Contact material AgNi | |
| H -- Contact material AgSnO | |

»» Contact Rating

Type	307	307H
Resistive load	5A 240VAC	8A 240VAC 10A 240VAC ^(※) 12A 125VAC ^(※)
Max. switching current	5A	12A
Max. switching voltage	277VAC	277VAC
Max. switching capacit	1200VA	1920VA

Note : 307H special version of 10A 240VAC 100K ops. can be selected.

»» Coil Rating (DC)

◆ Standard Type

Rated voltage (V)	Rated current $\pm 10\%$ at 23°C (mA)	Coil resistance $\pm 10\%$ at 23°C (Ω)	Max. continuous voltage at 70°C (307) at 85°C (307H)	Pick up voltage(Max.) at 23°C	Drop out voltage(Min.) at 23°C	Power consumption at rated voltage
3	150	20	130 % of rated voltage	75 % of rated voltage	5 % of rated voltage	approx. 0.45W
5	90.9	55				
6	75	80				
9	50	180				
12	37.5	320				
18	25	720				
24	18.8	1280				

◆ High sensitivity type

Rated voltage (V)	Rated current $\pm 10\%$ at 23°C (mA)	Coil resistance $\pm 10\%$ at 23°C (Ω)	Max. continuous voltage at 70°C (307) at 85°C (307H)	Pick up voltage(Max.) at 23°C	Drop out voltage(Min.) at 23°C	Power consumption at rated voltage
3	66.7	45	130 % of rated voltage	80 % of rated voltage	5 % of rated voltage	approx. 0.2W
5	40.0	125				
6	33.3	180				
9	22.2	405				
12	16.7	720				
18	11.1	1620				
24	8.3	2880				

»» Specification

Contact material	AgNi / AgSnO alloy	
Contact resistance ⁽¹⁾	100m Ω Max. (at 1A/6VDC by 4-wire resistance measurement)	
Operate time ⁽¹⁾	10ms Max.	
Release time ⁽¹⁾	5ms Max.	
Vibration resistance	Operating extremes	10 ~ 50Hz , amplitude 1.0 mm
	Damage limits	10 ~ 50Hz , amplitude 1.0 mm
Shock resistance	Operating extremes	10G
	Damage limits	100G
Life expectancy	Mechanical	10,000,000 ops. (frequency 18,000 ops./hr)
	Electrical	100,000 ops. (※)30,000 ops. (frequency 360 ops./hr)
Operating ambient temperature	307	-30 ~ +70°C (no freezing)
	307H	-40 ~ +85°C (no freezing) ⁽²⁾
Weight	Approx. 6 g	

Note : (1) Initial value. Operate and release time excluding contact bounce.

(2) Special version of high temperature 105°C can be selected.

(3) Unless otherwise specified, all tests are under room temperature and humidity.

(4) Consider the heat of PCB is necessary, please check the actual condition of PCB.

(5) Applying no diode to this relay. The life expectancy will be lower when a diode is used. To use a varistor (ZNR) could absorb the coil surge of relay that is recommended.

- (6) Do not use the relay exceeding the coil rating, contact rating and life expectancy, or this may cause the risk of overheating.
- (7) To assure optimum performance, avoid the relay from dropping, hitting, or other unnecessary shocks.
- (8) Do not switch the contacts without any load as the contact resistance may become increased rapidly.
- (9) Usage, transport and storage conditions
- 1. Temperature: -40~+85°C
 - 2. Humidity: 5 to 85% R.H.
 - 3. Pressure: 86 to 106 kPa
 - Furthermore, the humidity range varies with the temperature. So, use relays within the range indicated in the graph below.

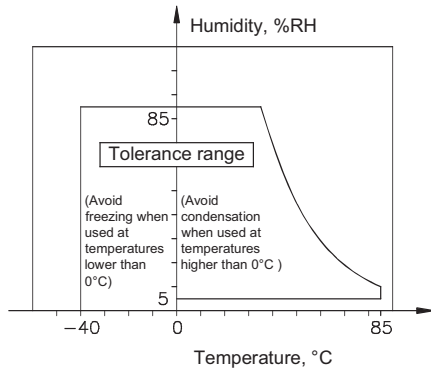

- (10) Please contact Song Chuan for the detailed information.

»» Insulation Data

Insulation resistance ⁽¹⁾	100 MΩ Min. (DC 500V)	
Dielectric strength ⁽¹⁾	Between open contact	: AC 1000V, 50/60Hz 1 min.
	Between contact and coil	: AC 2500V, 50/60Hz 1 min.
Insulation of IEC 61810-1		
Clearance / creepage distances	Between coil to contact	: Basic, ≥ 1.5mm / ≥ 2.5mm
	Between open contact	: Functional
Rated insulation voltage	250V	
Rated impulse withstand voltage	2500V	
Pollution degree	2	
Rated voltage	230 / 400V	
Overvoltage category	II	

Note : (1) Initial value.

»» Safety Approval

Certified	UL/CUL	TUV	VDE
	307, 307H	307	307H
File No.	E88991	R50128391	40028236

»» Safety Approval Rating

UL/CUL		TUV	VDE
307	307H	307	307H
5A 277VAC 5A 30VDC 1/4HP 125/250VAC	10A 277VAC 10A 30VDC 12A 125VAC 1/4HP 125/250VAC TV-3 (for AgSnO contact)	5A 250VAC 5A 30VDC	10A 250VAC T85 6A 250VAC T105

Note : If there is cleaning process and sealed type is selected, the vent-hole should be removed after the process.

»» Outline Dimensions

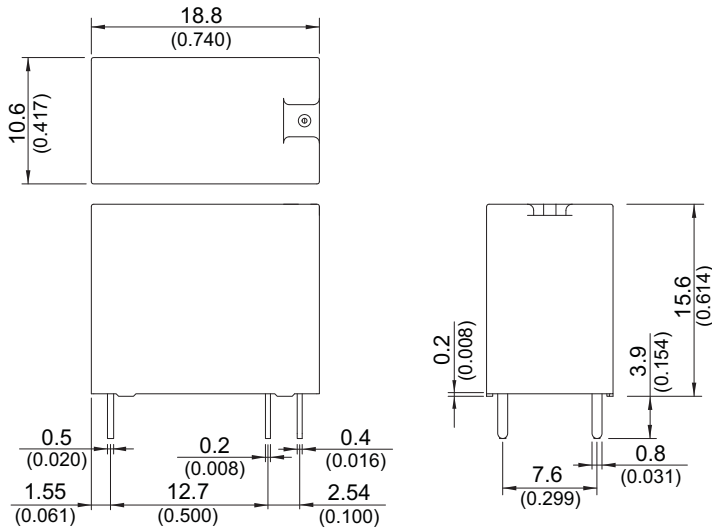

TOLERANCE:
 LESS THAN: 1(0.039) ±0.1(0.004)
 5(0.197) ±0.3(0.012)
 20(0.787) ±0.5(0.020)
 MORE THAN: 20(0.787) ±1(0.039)

»» Wiring Diagram BOTTOM VIEW

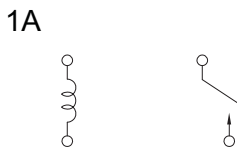

»» PC Board Layout BOTTOM VIEW

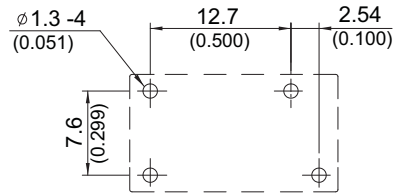

»» Engineering Data

