

SECTION C-C

- NOTES :
1. CONTACT-PLATED PHOSPHOR BRONZE.
 2. HOUSING : 15% GLASS-FILLED POLYESTER, COLOUR BLACK.
 3. COMPATIBLE WITH PCB HOLE PATTERN.
 4. FOR (0.635)/ .025 SQ. PINS THE LENGTH MUST BE (5.65)/ .222 MIN & (7.00)/ .276 MAX. TO ENSURE GOOD CONNECTION WITH CONTACT.

UPDATE AS PER GCNS	2012/01/13
EC NO: S2012-0542	2012/02/06
DRWN:ATSEE	2012/02/24
CHKD:SKANG	
APPR:MLONG	

QUALITY SYMBOLS	GENERAL TOLERANCES (UNLESS SPECIFIED)	
	mm	INCH
$\text{F} = 0$	4 PLACES ± ---	± ---
$\text{G} = 0$	3 PLACES ± ---	± ---
$\text{H} = 0$	2 PLACES ± 0.05	± ---
$\text{J} = 0$	1 PLACE ± 0.10	± ---
	ANGULAR ± ---°	

DIMENSION STYLE		SCALE	DESIGN UNITS	THIRD ANGLE PROJECTION
MM ONLY		NTS	METRIC	
DRAWN BY	DATE	TITLE		
DB	21/07/86	C-GRID III DUAL ROW VERTICAL P.C. BOARD CONNECTOR		
CHECKED BY	DATE			
DB	21/07/86	MOLEX INCORPORATED		
APPROVED BY	DATE			
MLONG	2012/02/24	SD-90151-001		
MATERIAL NO.	DOCUMENT NO.			
SEE TABLE		SHEET NO. 1 OF 2		

DRAFT WHERE APPLICABLE MUST REMAIN WITHIN DIMENSIONS		THIS DRAWING CONTAINS INFORMATION THAT IS PROPRIETARY TO MOLEX INCORPORATED AND SHOULD NOT BE USED WITHOUT WRITTEN PERMISSION	
--	--	---	--

PART NO. STRAIGHT PINS	NO.OF CKTS.	DIM." A"	DIM." B" (+0.00) -0.012	QTY. PER TUBE
90151-2X04	4	(2.54) .100	(5.08) .200	105
↑ 06	6	(5.08) .200	(7.62) .300	72
08	8	(7.62) .300	(10.16) .400	52
10	10	(10.16) .400	(12.70) .500	44
12	12	(12.70) .500	(15.24) .600	36
14	14	(15.24) .600	(17.78) .700	30
16	16	(17.78) .700	(20.32) .800	26
18	18	(20.32) .800	(22.86) .900	24
20	20	(22.86) .900	(25.40) 1.000	22
22	22	(25.40) 1.000	(27.94) 1.100	20
24	24	(27.94) 1.100	(30.48) 1.200	18
26	26	(30.48) 1.200	(33.02) 1.300	16
28	28	(33.02) 1.300	(35.56) 1.400	14
30	30	(35.56) 1.400	(38.10) 1.500	14
32	32	(38.10) 1.500	(40.64) 1.600	13
34	34	(40.64) 1.600	(43.18) 1.700	12
36	36	(43.18) 1.700	(45.72) 1.800	12
38	38	(45.72) 1.800	(48.26) 1.900	11
40	40	(48.26) 1.900	(50.80) 2.000	11
42	42	(50.80) 2.000	(53.34) 2.100	11
44	44	(53.34) 2.100	(55.88) 2.200	10
46	46	(55.88) 2.200	(58.42) 2.300	10
48	48	(58.42) 2.300	(60.96) 2.400	9
50	50	(60.96) 2.400	(63.50) 2.500	8
52	52	(63.50) 2.500	(66.04) 2.600	8
54	54	(66.04) 2.600	(68.58) 2.700	8
56	56	(68.58) 2.700	(71.12) 2.800	7
58	58	(71.12) 2.800	(73.66) 2.900	7
60	60	(73.66) 2.900	(76.20) 3.000	7
↓ 62	62	(76.20) 3.000	(78.74) 3.100	7
90151-2X64	64	(78.74) 3.100	(81.28) 3.200	6

PLATING VERSION A
PRE-PLATED HOT DIP TIN
1.0 TO 2.5 um (.000040" TO .000100").

PLATING VERSION E
1.27 TO 1.78 um (.000050" TO .000070") NICKEL
OVERALL, 0.38 TO 0.64 um (.000015" TO .000025")
GOLD ON CONTACT AREA (OVER NICKEL).
3 TO 5 um (.000120" TO .000200") TIN
ON SOLDER TAILS (OVER NICKEL).

PLATING VERSION F.
1.27 TO 1.78 um (.000050" TO .000070") NICKEL
OVERALL, 0.76 TO 1.0 um (.000030" TO .000040")
GOLD ON CONTACT AREA (OVER NICKEL).
3 TO 5 um (.000120" TO .000200") TIN
ON SOLDER TAILS (OVER NICKEL).

PLATING VERSION G.
1.27 TO 1.78 um (.000050" TO .000070") NICKEL
OVERALL, 0.125 um MIN. (.000005" MIN.) GOLD FLASH
ON CONTACT AREA (OVER NICKEL).
3 TO 5 um (.000120" TO .000200") TIN
ON SOLDER TAILS (OVER NICKEL).

PLATING VERSION N.
1.27 TO 1.78 um (.000050" TO .000070") NICKEL
OVERALL, 0.76 TO 2.6 um (.000030" TO .000100")
GOLD ON CONTACT AREA (OVER NICKEL).
4 um (.000120") MINIMUM TIN
ON SOLDER TAILS (OVER NICKEL).

STANDARD PRODUCTS

90151-XXYY
INDICATES NO. OF CIRCUITS.
PLATING CODE.
1 = VERSION A.
2 = VERSION E.
3 = VERSION F.
4 = VERSION N.
5 = VERSION G.
SEE CHART

UPDATE AS PER GCNS IEC NO: S2012-0542 DRWN:ATSEE 2012/01/13 CHYKD:SKANG 2012/02/06 APPR:MLONG 2012/02/24	QUALITY SYMBOLS F=0 E=0 A=0	GENERAL TOLERANCES (UNLESS SPECIFIED)		DIMENSION STYLE MM ONLY		SCALE NTS	DESIGN UNITS METRIC	THIRD ANGLE PROJECTION
		4 PLACES ± --- ± --- 3 PLACES ± --- ± --- 2 PLACES ± 0.05 ± --- 1 PLACE ± 0.10 ± --- ANGULAR ± ---°	mm INCH	DRAWN BY DB	DATE 21/07/86	TITLE C-GRID III DUAL ROW VERTICAL P.C. BOARD CONNECTOR		
		DRAFT WHERE APPLICABLE MUST REMAIN WITHIN DIMENSIONS	SEE TABLE	CHECKED BY DB	DATE 21/07/86	MOLEX INCORPORATED		
		MATERIAL NO.	APPROVED BY MLONG	DATE 2012/02/24	DOCUMENT NO. SD-90151-001	SHEET NO. 2 OF 2		

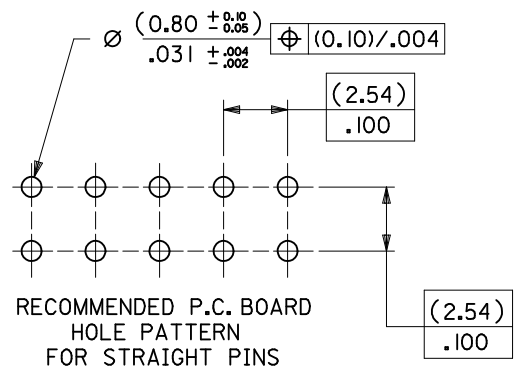
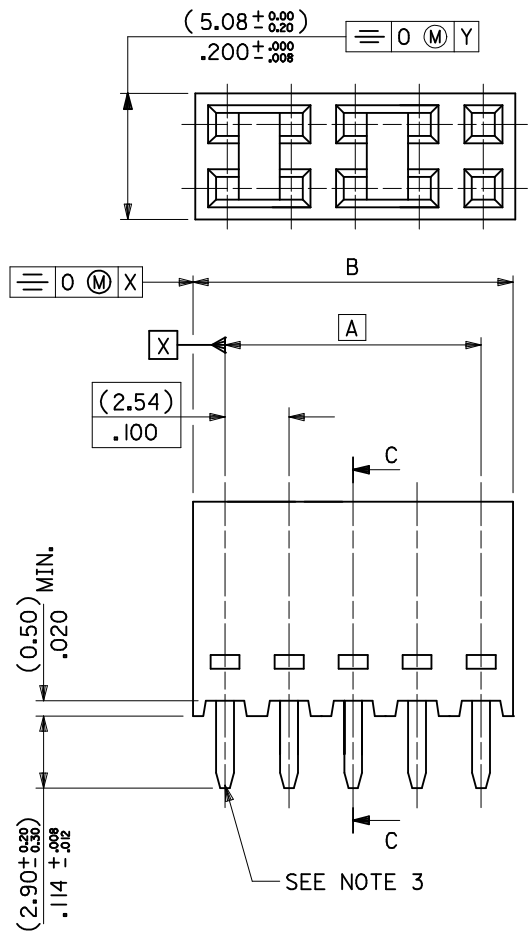

RECOMMENDED P.C. BOARD HOLE PATTERN FOR STRAIGHT PINS

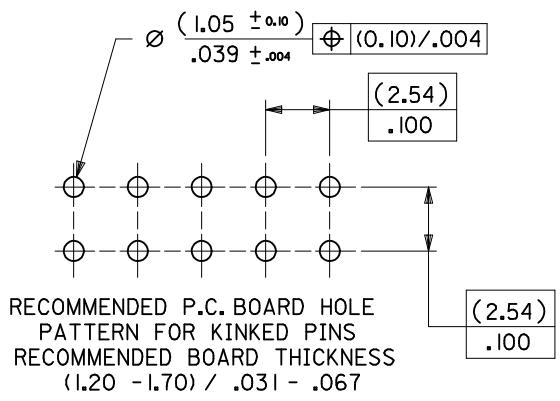

RECOMMENDED P.C. BOARD HOLE PATTERN FOR KINKED PINS
RECOMMENDED BOARD THICKNESS (1.20 - 1.70) / .031 - .067

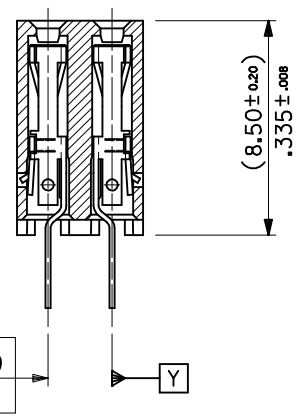

SECTION C-C

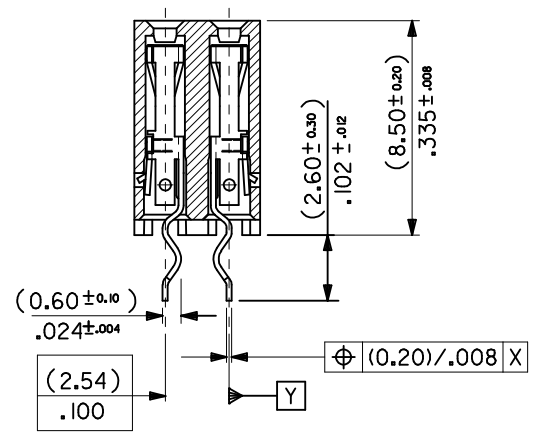

SECTION C-C

NOTES

- 1) CONTACT-PLATED PHOSPHOR BRONZE.
- 2) HOUSING-15% GLASS FILLED POLYESTER. COLOUR-BLACK.
- 3) COMPATIBLE WITH PCB HOLE PATTERN.
- 4) FOR (0.635)/.025 SQ. MALE PINS THE LENGTH MUST BE (5.65)/.222 MIN & (7.00)/.276 MAX. TO ENSURE GOOD CONNECTION WITH CONTACT.

6	AF
5	AD
4	AD
3	AD
2	AG
1	AH

ADD INSET FOR GATE EC NO: E2009-0250 DRWN: BMAGUIRE 2008/12/08 CHKD: 2008/12/08 APPR: BMAGUIRE 2008/12/08	QUALITY SYMBOLS ▽=0 ◻=0	GENERAL TOLERANCES (UNLESS SPECIFIED)		DIMENSION STYLE MM ONLY	SCALE 1:1	DESIGN UNITS METRIC	THIRD ANGLE PROJECTION		
		4 PLACES ± --- ± --- 3 PLACES ± --- ± --- 2 PLACES ± 0.05 ± --- 1 PLACE ± 0.10 ± ---	mm INCH	DRAWN BY DB	DATE 21/07/86	TITLE C-GRID III DUAL ROW VERTICAL P.C. BOARD CONNECTOR			
		ANGULAR ± ---°		CHECKED BY	DATE	MOLEX INCORPORATED			
		DRAFT WHERE APPLICABLE MUST REMAIN WITHIN DIMENSIONS		APPROVED BY	DATE	MATERIAL NO. SEE CHART	DOCUMENT NO. SDA-90151	SHEET NO. 1 OF 5	
AH		REV	THIS DRAWING CONTAINS INFORMATION THAT IS PROPRIETARY TO MOLEX INCORPORATED AND SHOULD NOT BE USED WITHOUT WRITTEN PERMISSION						

SEE CHART
PART NO. SDA-90151
DWG. NO.

PART NO. STRAIGHT PINS	PART NO. KINKED PINS	NO.OF CKTS.	DIM." A"	DIM." B" (± 0.00): ± 0.02	QTY. PER TUBE
90151-2X04	90151-3X04	4	(2.54) .100	(5.08) .200	105
▲ ▲ 06	▲ ▲ 06	6	(5.08) .200	(7.62) .300	72
08	08	8	(7.62) .300	(10.16) .400	52
10	10	10	(10.16) .400	(12.70) .500	44
12	12	12	(12.70) .500	(15.24) .600	36
14	14	14	(15.24) .600	(17.78) .700	30
16	16	16	(17.78) .700	(20.32) .800	26
18	18	18	(20.32) .800	(22.86) .900	24
20	20	20	(22.86) .900	(25.40) 1.000	22
22	22	22	(25.40) 1.000	(27.94) 1.100	20
24	24	24	(27.94) 1.100	(30.48) 1.200	18
26	26	26	(30.48) 1.200	(33.02) 1.300	16
28	28	28	(33.02) 1.300	(35.56) 1.400	14
30	30	30	(35.56) 1.400	(38.10) 1.500	14
32	32	32	(38.10) 1.500	(40.64) 1.600	13
34	34	34	(40.64) 1.600	(43.18) 1.700	12
36	36	36	(43.18) 1.700	(45.72) 1.800	12
38	38	38	(45.72) 1.800	(48.26) 1.900	11
40	40	40	(48.26) 1.900	(50.80) 2.000	11
42	42	42	(50.80) 2.000	(53.34) 2.100	11
44	44	44	(53.34) 2.100	(55.88) 2.200	10
46	46	46	(55.88) 2.200	(58.42) 2.300	10
48	48	48	(58.42) 2.300	(60.96) 2.400	9
50	50	50	(60.96) 2.400	(63.50) 2.500	8
52	52	52	(63.50) 2.500	(66.04) 2.600	8
54	54	54	(66.04) 2.600	(68.58) 2.700	8
56	56	56	(68.58) 2.700	(71.12) 2.800	7
58	58	58	(71.12) 2.800	(73.66) 2.900	7
60	60	60	(73.66) 2.900	(76.20) 3.000	7
▼ ▼ 62	▼ ▼ 62	62	(76.20) 3.000	(78.74) 3.100	7
90151-2X64	90151-3X64	64	(78.74) 3.100	(81.28) 3.200	6

PLATING VERSION A

PRE-PLATED HOT DIP TIN
1.0 TO 2.5 um (.000040" TO .000100").

PLATING VERSION E

1.27 TO 1.78 um (.000050" TO .000070") NICKEL
OVERALL, 0.38 TO 0.64 um (.000015" TO .000025")
GOLD ON CONTACT AREA (OVER NICKEL).
3 TO 5 um (.000120" TO .000200") TIN
ON SOLDER TAILS (OVER NICKEL).

PLATING VERSION F.

1.27 TO 1.78 um (.000050" TO .000070") NICKEL
OVERALL, 0.76 TO 1.0 um (.000030" TO .000040")
GOLD ON CONTACT AREA (OVER NICKEL).
3 TO 5 um (.000120" TO .000200") TIN
ON SOLDER TAILS (OVER NICKEL).

PLATING VERSION G.

1.27 TO 1.78 um (.000050" TO .000070") NICKEL
OVERALL, 0.125 um MIN. (.000005" MIN.) GOLD FLASH
ON CONTACT AREA (OVER NICKEL).
3 TO 5 um (.000120" TO .000200") TIN
ON SOLDER TAILS (OVER NICKEL).

PLATING VERSION N.

1.27 TO 1.78 um (.000050" TO .000070") NICKEL
OVERALL, 0.76 TO 2.6 um (.000030" TO .000100")
GOLD ON CONTACT AREA (OVER NICKEL).
4 um (.000120") MINIMUM TIN
ON SOLDER TAILS (OVER NICKEL).

STANDARD PRODUCTS

90151-XXYY

INDICATES NO. OF CIRCUITS.

- PLATING CODE.
1 = VERSION A.
2 = VERSION E.
3 = VERSION F.
4 = VERSION N.
5 = VERSION G.

SEE CHART

FOR PREVIOUS
DRAWING ISSUES
SEE MRI.

LEAD FREE CONVERSION NEW BORDER ADDED EC NO. E2004-0610 DRAWN: PSHEAHAN 06/01/2004 CHK: APPR:	QUALITY SYMBOLS MAJOR CRITICAL C	GENERAL TOLERANCES: (UNLESS SPECIFIED)		SCALE	DESIGN UNITS	THIRD ANGLE PROJECTION	DIMENSIONS:		SHT	REV
		mm	INCH	mm	INCH		mm	INCH	mm	INCH
AH REV	DESCRIPTION	DRAWN BY & DATE DB 14/ 7/87		TITLE:		C-GRID III DUAL ROW VERTICAL P.C. BOARD CONNECTOR				
		CHECKED BY & DATE		APPROVED BY & DATE		MOLEX INCORPORATED				
DRAFT WHERE APPLICABLE MUST REMAIN WITHIN DIMENSIONS		ANGULAR: ± °		CAD FILENAME SA90151X2 DGN	MATERIAL NO. SEE CHART	DRAWING NO. SDA-90151	SHEET NO. 20F	THIS DRAWING CONTAINS INFORMATION THAT IS PROPRIETARY TO MOLEX INCORPORATED AND SHOULD NOT BE USED WITHOUT WRITTEN PERMISSION.		