

SPECIFICATION

Customer : 上海禹华

Applied To :

Product Name : Speaker

Model Name : KP1634SS1

Drawing No. : KFC1889

Signature of Approval

| |
|--|
| |
|--|

Signature of KEPO

| Approved by | Checked by | Issued by | Date |
|-------------|------------|-----------|------|
| | | | |



Ningbo Kepo Electronics Co.,Ltd.

Address: No.25 Baoyuan Road Dongqian Lake Industrial Area
Dongqian Lake, Ningbo315121, China

Tel: +86(574)88371186, 88370330

Fax: +86(574)88370329

<http://www.chinaacoustic.com>

E-mail: Sales@kepo.com.cn

| | | |
|---------------------------|--------------|---------|
| Specification for Speaker | Page | 2/9 |
| Model No. : KP1634SS1 | Revision No. | 1.0 |
| | Drawing No. | KFC1889 |

CONTENTS

1. Scope
2. General
3. Electrical and Acoustic Characteristics.
4. Reliability Test
5. Measurement Block Diagram & Response curve
6. Structure
7. Dimensions
8. Packing
9. Revision

| | | | |
|---------------------------|-----------|--------------|---------|
| Specification for Speaker | | Page | 3/9 |
| | | Revision No. | 1.0 |
| Model No. : | KP1634SS1 | Drawing No. | KFC1889 |

1. Scope

This specification is applied to the dynamic speaker which is used all of the electrical acoustic product.

- compact, rich sound
- applications: mobile phone, PDA, notebook computer, etc. ..

2. General

- 2.1 Out-Diameter : 16 mm
- 2.2 Height : 3.5 mm
- 2.3 Weight : 1.80 gr.
- 2.4 Operating Temperature range:
-20~+70℃ without loss of function
- 2.5 Store Temperature range:
-40~+85℃ without loss of function

3. Electrical and Acoustic Characteristics.

Test condition : 15 ~ 35 ℃ , 25% ~ 85% RH, 860~1060 mbar

| | Items | Specification |
|---|----------------------|---|
| 1 | Impedance | 8 Ω ± 15%(at 1Vrms,1.5kHz) |
| 2 | Sound Pressure Level | 90dB ± 3dB(1kHz/1V/0.1M) |
| 3 | Resonance Frequency | 900Hz ± 20% |
| 4 | Frequency Range | F _o ~ 20.0kHz |
| 5 | Input Power | Rated 0.5W / Max.1.0W |
| 6 | Distortion | <10% Max. at 2kHz/2Vrms |
| 7 | Buzz and Rattle | Should not be audible buzzes,rattles when the 2.0V sine wave signal swept at frequency range. |

| | | | |
|---------------------------|--|--------------|---------|
| Specification for Speaker | | Page | 4/9 |
| Model No. : KP1634SS1 | | Revision No. | 1.0 |
| | | Drawing No. | KFC1889 |

4. Reliability Test

After test(1~7item), the speaker S.P.L . difference shall be within $\pm 3\text{dB}$, and the appearance not exist any change to be harmful to normal operation(e.g. cracks,rusts,damages and especially distortion).

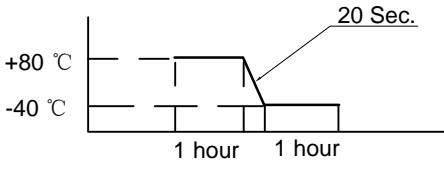
| | Item | Specification |
|---|-----------------------|--|
| 1 | High Temperature Test | After being placed in a chamber with $+85\pm 3\text{ }^\circ\text{C}$ for 96 hours and then being placed in natural condition for 1 hour, speaker shall be measured. |
| 2 | Low Temperature Test | After being placed in a chamber with $-40\pm 3\text{ }^\circ\text{C}$ for 96 hours and then being placed in natural condition for 1 hour, speaker shall be measured. |
| 3 | Humidity Test | After being placed in a chamber with 85 to 90%R.H. at $+40\pm 2\text{ }^\circ\text{C}$ for 96 hours and then being placed in natural condition for 1 hour, speaker shall be measured. |
| 4 | Thermal Shock Test | <p>After being placed in a chamber at $+80\text{ }^\circ\text{C}$ for 1 hour, then speaker shall be placed in a chamber at $-40\text{ }^\circ\text{C}$ for 1 hour(1 cycle is the below diagram).</p> <p>After 6 above cycles, speaker shall be measured after being placed in natural condition for 1 hour.</p>  |
| 5 | Vibration Test | After being applied vibration of amplitude of 1.5mm with 10 to 55Hz band of vibration frequency to each of 3 perpendicular directions for 1 hour, then placed in natural condition for 1 hour, speaker shall be measured. |
| 6 | Drop Test | The speaker when mounted in the jig which weight 85g~100g, shall with stand 15 times random drops from a height of 1.5 meter to a concrete floor faced with 5mm thick hard wood board.and be nothing mechanical damage. |
| 7 | Load test | After being applied loading white noise with input power 0.5W(2.0Vrms.) for 96 hours, then placed in natural condition for 1 hour, speaker shall be measured. |
| 8 | Insulation test | When they are measured with DC 100V the insulation resistance between v.c. terminal and frame must be more than 1 M Ω |

| | | | |
|--|--|--------------|---------|
| Specification for Speaker | | Page | 5/9 |
| Model No. : KP1634SS1 | | Revision No. | 1.0 |
| | | Drawing No. | KFC1889 |

5. Measurement Block Diagram & Response curve

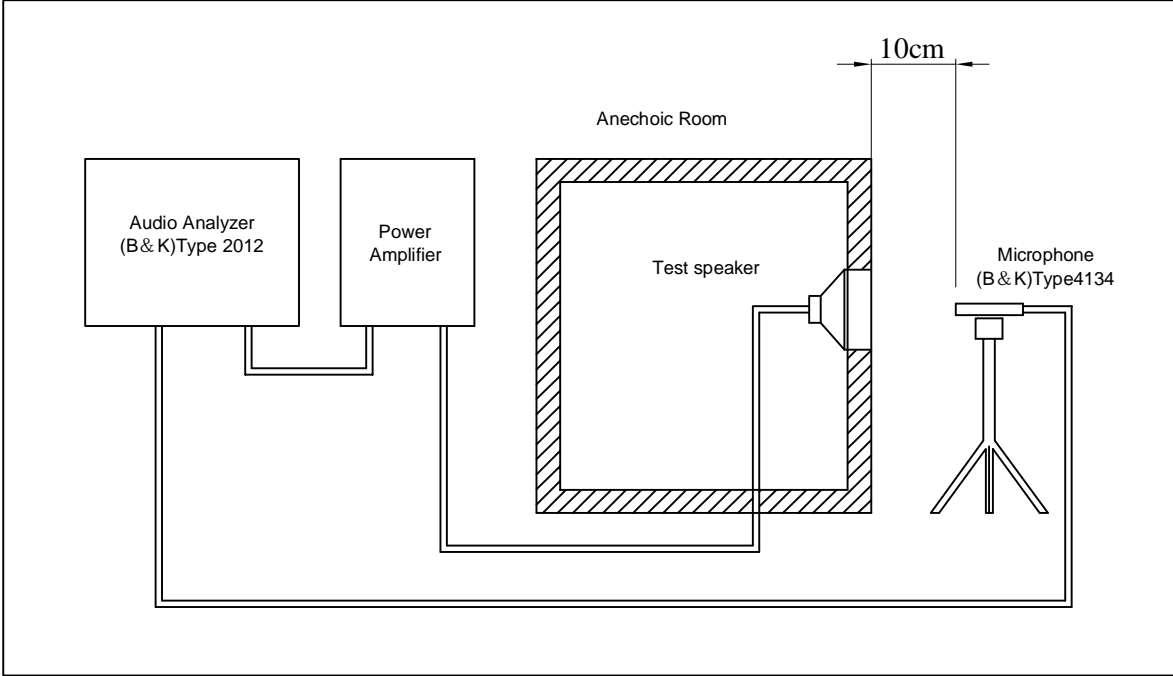

SPL vs Freq

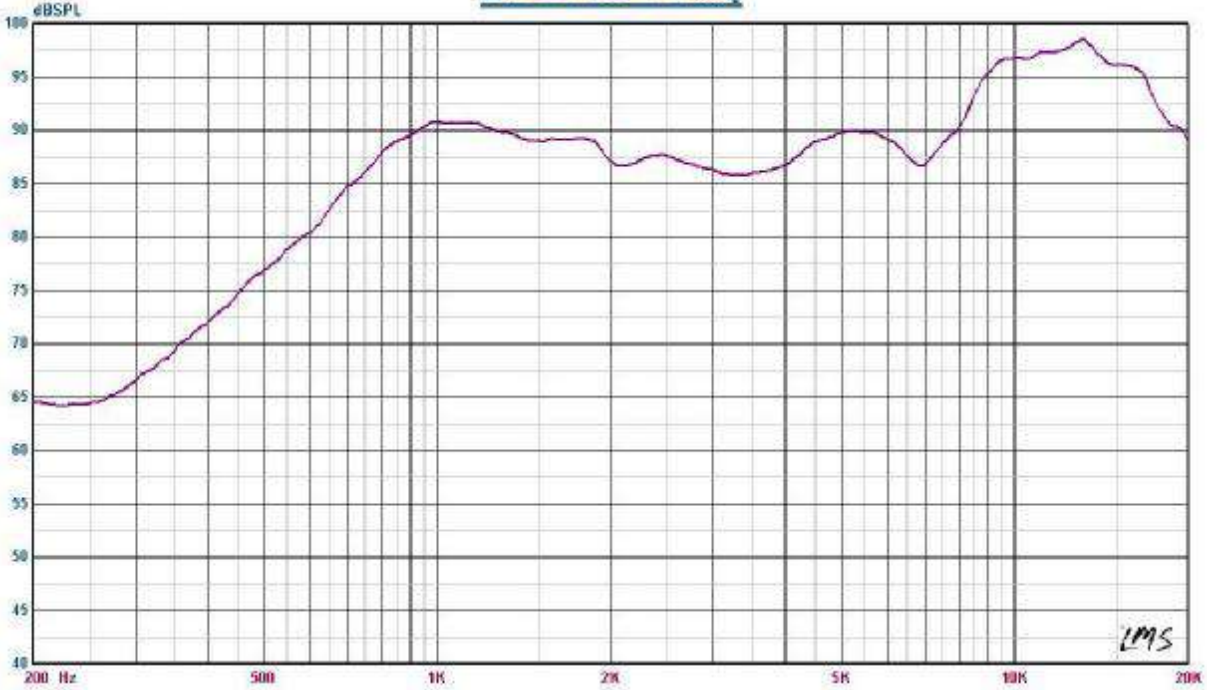

| | | | |
|------------------------------------|-----------|--------------|---------|
| Specification for Two Mode Speaker | | Page | 6/9 |
| | | Revision No. | 1.0 |
| Model No. : | KP1634SS1 | Drawing No. | KFC1889 |

6. Structure

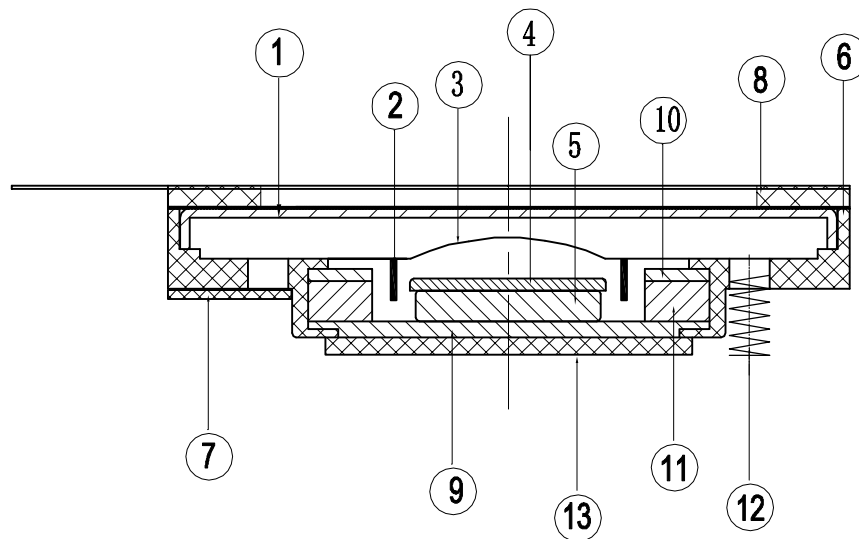

| 13 | Cushion | 1 | Sponge | 800+Sponge0.4 |
|-----|-----------|------|----------------|-----------------------|
| 12 | Spring | 1 | spring steel | |
| 11 | Magnet | 1 | Nd-Fe-B | |
| 10 | Plate | 1 | SPC | |
| 9 | Plate | 1 | SPC | |
| 8 | Gasket | 1 | unwoven fabric | 800+2B+800+PSR0.3+800 |
| 7 | Screen | 1 | net120# | |
| 6 | Frame | 1 | PBT | |
| 5 | Magnet | 1 | Nd-Fe-B | |
| 4 | Plate | 1 | SPC | |
| 3 | Diaphragm | 1 | PEN | |
| 2 | Coil | 1 | Copper | |
| 1 | Cap | 1 | SUS304 | |
| No. | Part Name | Q'TY | Material | Remarks |

| | | | |
|---------------------------|-----------|--------------|---------|
| Specification for Speaker | | Page | 7/9 |
| | | Revision No. | 1.0 |
| Model No. : | KP1634SS1 | Drawing No. | KFC1889 |

7. Dimensions

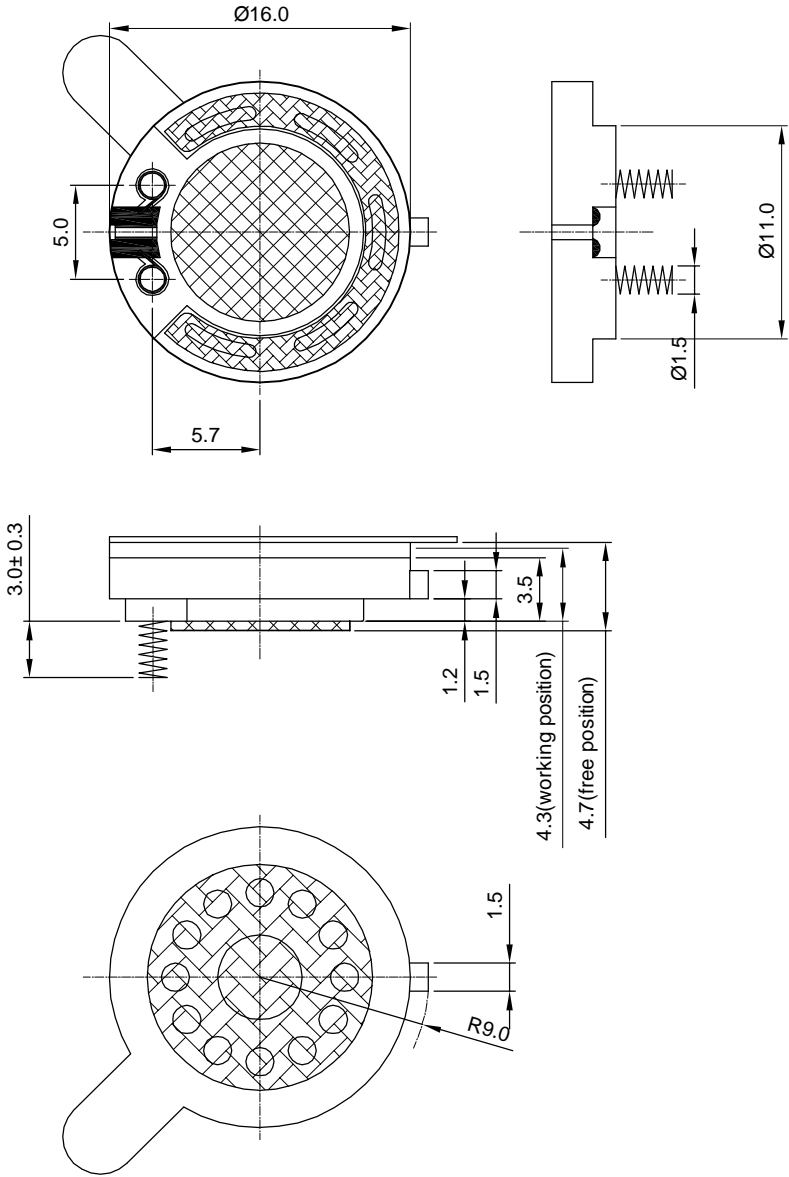

FIRST ANGLE PROJECTION

UNIT : mm
Tolerance : ±0.2

| | | | |
|---------------------------|-----------|--------------|---------|
| Specification for Speaker | | Page | 8/9 |
| | | Revision No. | 1.0 |
| Model No. : | KP1634SS1 | Drawing No. | KFC1889 |

8. Packing

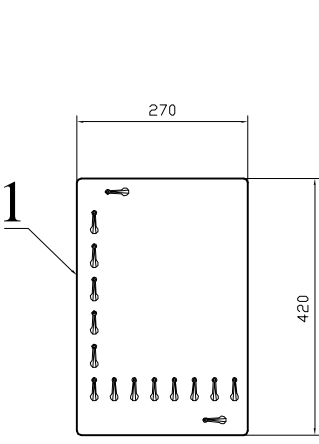

100Pcs

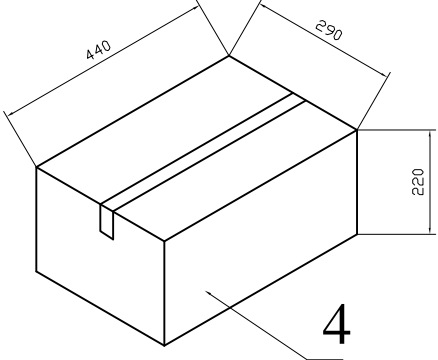
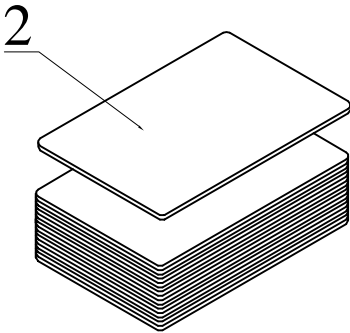
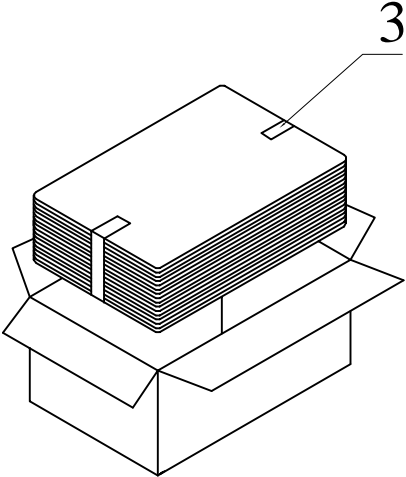

QTY: 2000Pcs
440 x290 x220

