



# STB34NM60ND, STF34NM60ND STP34NM60ND, STW34NM60ND

N-channel 600 V, 0.097  $\Omega$ , 29 A FDmesh™ II Power MOSFET  
(with fast diode) D<sup>2</sup>PAK, TO-220FP, TO-220, TO-247

Preliminary data

## Features

Order codes	V <sub>DSS</sub> @T <sub>J</sub> max.	R <sub>DS(on)</sub> max.	I <sub>D</sub>
STB34NM60ND STF34NM60ND STP34NM60ND STW34NM60ND	650 V	0.110 $\Omega$	29 A

- The world's best R<sub>DS(on)</sub> in TO-220 amongst the fast recovery diode devices
- 100% avalanche tested
- Low input capacitance and gate charge
- Low gate input resistance
- Extremely high dv/dt and avalanche capabilities

## Applications

- Switching applications

## Description

These FDmesh™ II Power MOSFETs with intrinsic fast-recovery body diode are produced using the second generation of MDmesh™ technology. Utilizing a new strip-layout vertical structure, these revolutionary devices feature extremely low on-resistance and superior switching performance. They are ideal for bridge topologies and ZVS phase-shift converters.

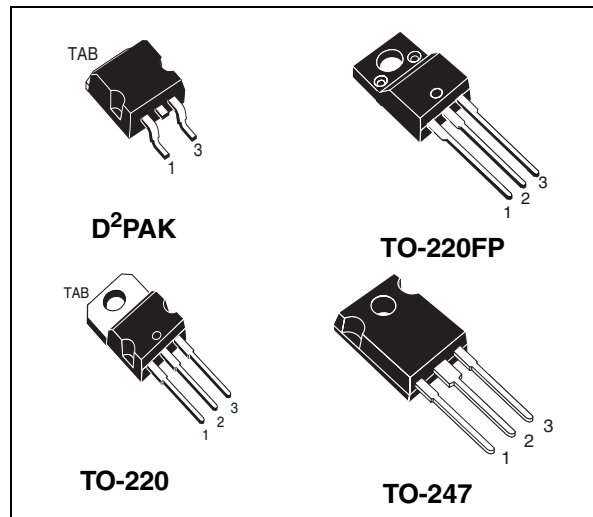
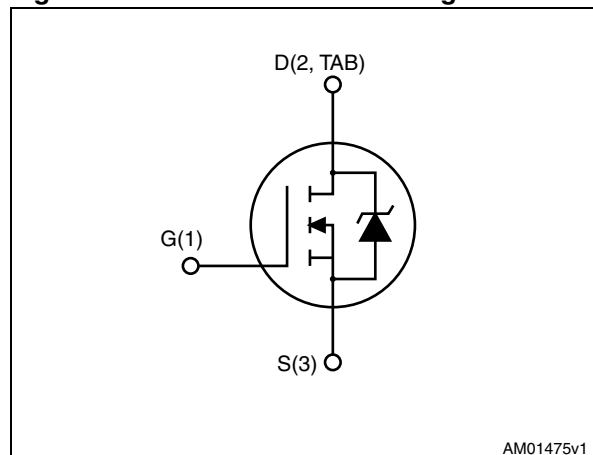

Figure 1. Internal schematic diagram



AM01475v1

Table 1. Device summary

Order codes	Marking	Package	Packaging
STB34NM60ND	34NM60ND	D <sup>2</sup> PAK	Tape and reel
STF34NM60ND	34NM60ND	TO-220FP	Tube
STP34NM60ND	34NM60ND	TO-220	Tube
STW34NM60ND	34NM60ND	TO-247	Tube

# Contents

<b>1</b>	<b>Electrical ratings</b> .....	<b>3</b>
<b>2</b>	<b>Electrical characteristics</b> .....	<b>4</b>
2.1	Electrical characteristics (curves) .....	6
<b>3</b>	<b>Test circuits</b> .....	<b>9</b>
<b>4</b>	<b>Package mechanical data</b> .....	<b>10</b>
<b>5</b>	<b>Packaging mechanical data</b> .....	<b>18</b>
<b>6</b>	<b>Revision history</b> .....	<b>20</b>

# 1 Electrical ratings

**Table 2. Absolute maximum ratings**

Symbol	Parameter	Value		Unit
		D <sup>2</sup> PAK, TO-220, TO-247	TO-220FP	
V <sub>DS</sub>	Drain-source voltage (V <sub>GS</sub> = 0)	600		V
V <sub>GS</sub>	Gate- source voltage	± 25		V
I <sub>D</sub>	Drain current (continuous) at T <sub>C</sub> = 25 °C	29	29 <sup>(1)</sup>	A
I <sub>D</sub>	Drain current (continuous) at T <sub>C</sub> = 100 °C	18	18 <sup>(1)</sup>	A
I <sub>DM</sub> <sup>(2)</sup>	Drain current (pulsed)	116	116 <sup>(1)</sup>	A
P <sub>TOT</sub>	Total dissipation at T <sub>C</sub> = 25 °C	190	40	W
V <sub>ISO</sub>	Insulation withstand voltage (RMS) from all three leads to external heat sink (t=1 s; T <sub>C</sub> =25 °C)		2500	V
dv/dt <sup>(3)</sup>	Peak diode recovery voltage slope	15		V/ns
T <sub>stg</sub>	Storage temperature	- 55 to 150		°C
T <sub>J</sub>	Max. operating junction temperature	150		

1. Current limited by package

2. Pulse width limited by safe operating area

3.  $I_{SD} \leq 29$  A,  $di/dt \leq 600$  A/ $\mu$ s,  $V_{DD} = 80\% V_{(BR)DSS}$ ,  $V_{Peak} < V_{(BR)DSS}$

**Table 3. Thermal data**

Symbol	Parameter	TO-220	TO-247	D <sup>2</sup> PAK	TO-220FP	Unit
R <sub>thj-case</sub>	Thermal resistance junction-case max	0.66			3.1	°C/W
R <sub>thj-amb</sub>	Thermal resistance junction-ambient max	62.5	50		62.5	°C/W
R <sub>thj-pcb</sub>	Thermal resistance junction-pcb max			30		°C/W

**Table 4. Avalanche characteristics**

Symbol	Parameter	Max value	Unit
I <sub>AR</sub>	Avalanche current, repetitive or not-repetitive (pulse width limited by T <sub>J</sub> max)	7	A
E <sub>AS</sub>	Single pulse avalanche energy (starting T <sub>J</sub> = 25 °C, I <sub>D</sub> = I <sub>AR</sub> , V <sub>DD</sub> = 50 V)	345	mJ

## 2 Electrical characteristics

( $T_{CASE} = 25\text{ °C}$  unless otherwise specified)

**Table 5. On/off states**

Symbol	Parameter	Test conditions	Min.	Typ.	Max.	Unit
$V_{(BR)DSS}$	Drain-source breakdown voltage ( $V_{GS} = 0$ )	$I_D = 1\text{ mA}$	600			V
$I_{DSS}$	Zero gate voltage drain current ( $V_{GS} = 0$ )	$V_{DS} = 600\text{ V}$ $V_{DS} = 600\text{ V}, T_C = 125\text{ °C}$			1 100	$\mu\text{A}$ $\mu\text{A}$
$I_{GSS}$	Gate-body leakage current ( $V_{DS} = 0$ )	$V_{GS} = \pm 25\text{ V}$			100	nA
$V_{GS(th)}$	Gate threshold voltage	$V_{DS} = V_{GS}, I_D = 250\text{ }\mu\text{A}$	3	4	5	V
$R_{DS(on)}$	Static drain-source on resistance	$V_{GS} = 10\text{ V}, I_D = 14.5\text{ A}$		0.097	0.110	$\Omega$

**Table 6. Dynamic**

Symbol	Parameter	Test conditions	Min.	Typ.	Max.	Unit
$C_{iss}$ $C_{oss}$ $C_{rss}$	Input capacitance Output capacitance Reverse transfer capacitance	$V_{DS} = 50\text{ V}, f = 1\text{ MHz},$ $V_{GS} = 0$	-	2785 168 5	-	pF pF pF
$C_{oss\text{ eq.}}^{(1)}$	Equivalent output capacitance	$V_{GS} = 0, V_{DS} = 0\text{ to }480\text{ V}$	-	43.8	-	pF
$t_{d(on)}$ $t_r$ $t_{d(off)}$ $t_f$	Turn-on delay time Rise time Turn-off delay time Fall time	$V_{DD} = 300\text{ V}, I_D = 14.5\text{ A}$ $R_G = 4.7\text{ }\Omega, V_{GS} = 10\text{ V}$ (see <a href="#">Figure 18</a> and <a href="#">23</a> )	-	30 53.4 111 61.8	-	ns ns ns ns
$Q_g$ $Q_{gs}$ $Q_{gd}$	Total gate charge Gate-source charge Gate-drain charge	$V_{DD} = 480\text{ V}, I_D = 29\text{ A},$ $V_{GS} = 10\text{ V},$ (see <a href="#">Figure 19</a> )	-	80.4 16 41.4	-	nC nC nC
$R_g$	Gate input resistance	$f = 1\text{ MHz}, \text{ open drain}$	-	2.87	-	$\Omega$

1.  $C_{oss\text{ eq.}}$  is defined as a constant equivalent capacitance giving the same charging time as  $C_{oss}$  when  $V_{DS}$  increases from 0 to 80%  $V_{DSS}$

Table 7. Source drain diode

Symbol	Parameter	Test conditions	Min.	Typ.	Max.	Unit
$I_{SD}$	Source-drain current		-		29	A
$I_{SDM}^{(1)}$	Source-drain current (pulsed)		-		116	A
$V_{SD}^{(2)}$	Forward on voltage	$I_{SD} = 29\text{ A}, V_{GS} = 0$	-		1.6	V
$t_{rr}$	Reverse recovery time	$I_{SD} = 29\text{ A}, V_{DD} = 60\text{ V}$ $di/dt = 100\text{ A}/\mu\text{s}$ (see <a href="#">Figure 20</a> )	-	175		ns
$Q_{rr}$	Reverse recovery charge			1.4		$\mu\text{C}$
$I_{RRM}$	Reverse recovery current			16		A
$t_{rr}$	Reverse recovery time	$I_{SD} = 29\text{ A}, V_{DD} = 60\text{ V}$ $di/dt = 100\text{ A}/\mu\text{s}$ , $T_J = 150\text{ }^\circ\text{C}$ (see <a href="#">Figure 20</a> )	-	255		ns
$Q_{rr}$	Reverse recovery charge			2.6		$\mu\text{C}$
$I_{RRM}$	Reverse recovery current			20		A

1. Pulse width limited by safe operating area
2. Pulsed: Pulse duration = 300  $\mu\text{s}$ , duty cycle 1.5%.

## 2.1 Electrical characteristics (curves)

Figure 2. Safe operating area for TO-220FP

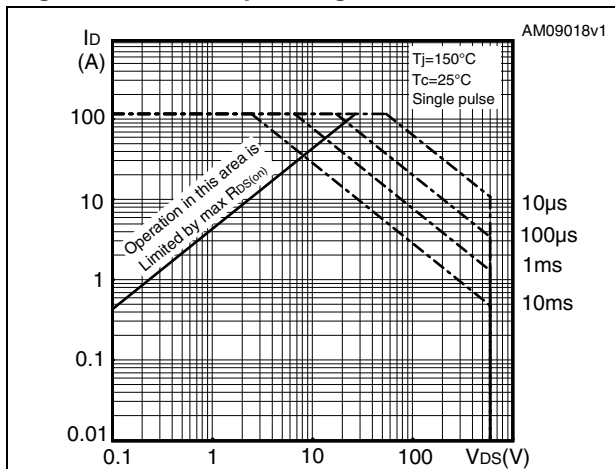

Figure 3. Thermal impedance for TO-220FP

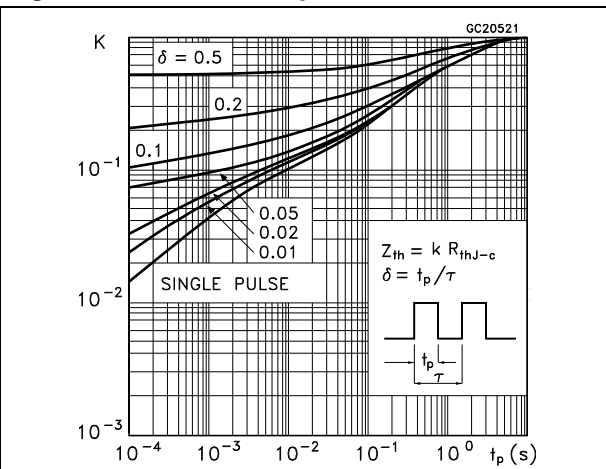

Figure 4. Safe operating area for TO-220 and D<sup>2</sup>PAK

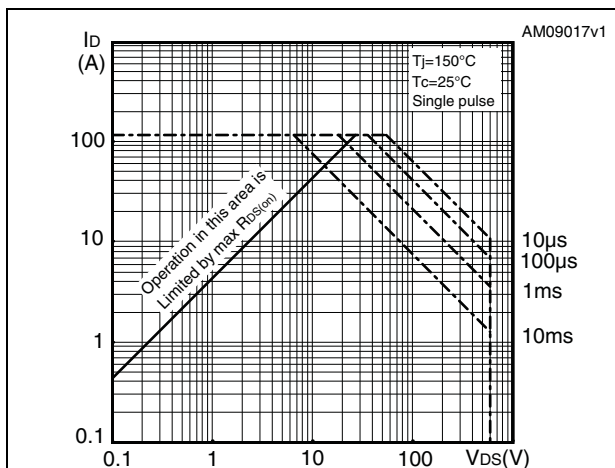

Figure 5. Thermal impedance for TO-220 and D<sup>2</sup>PAK

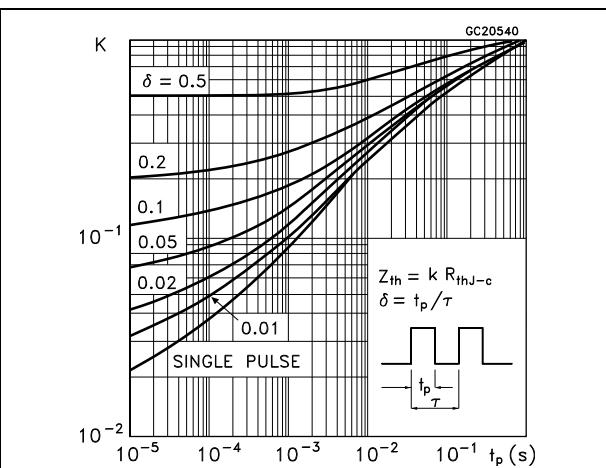

Figure 6. Safe operating area for TO-247

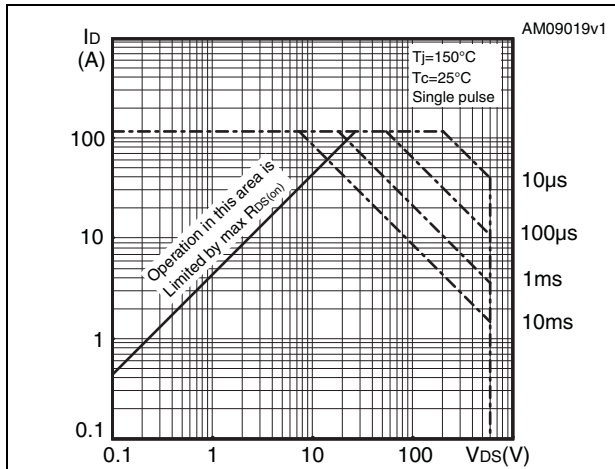

Figure 7. Thermal impedance for TO-247

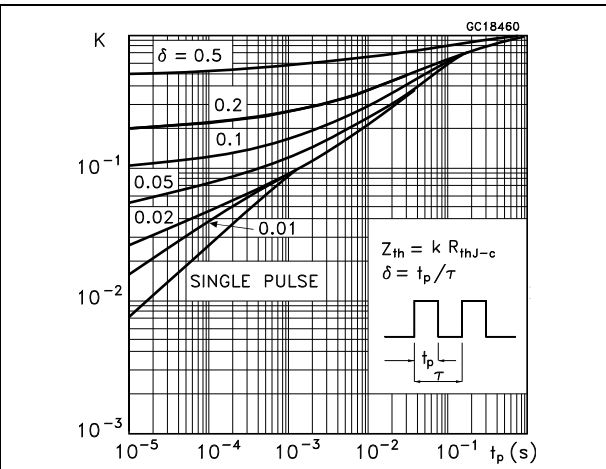

Figure 8. Output characteristics

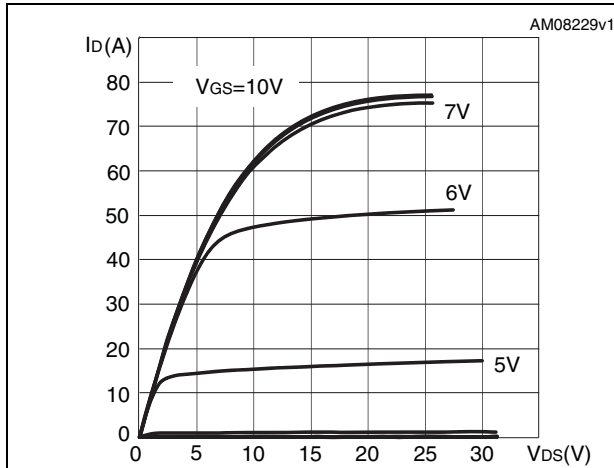

Figure 9. Transfer characteristics

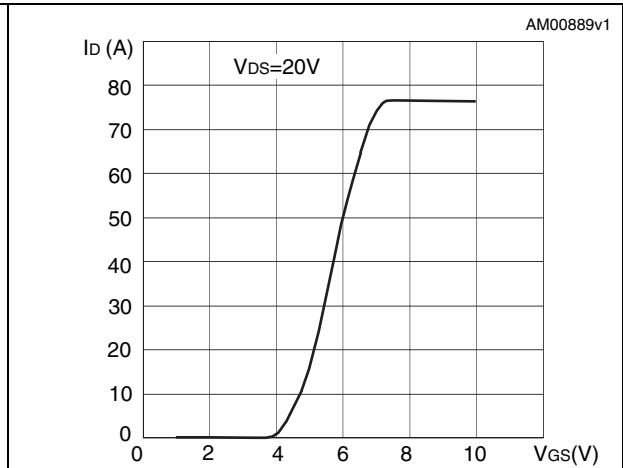

Figure 10. Gate charge vs gate-source voltage

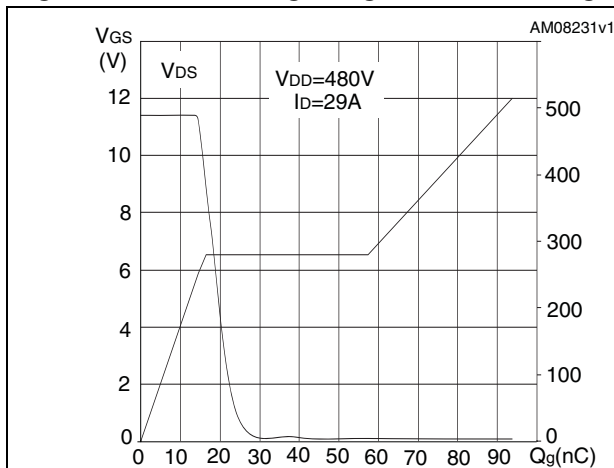

Figure 11. Static drain-source on resistance

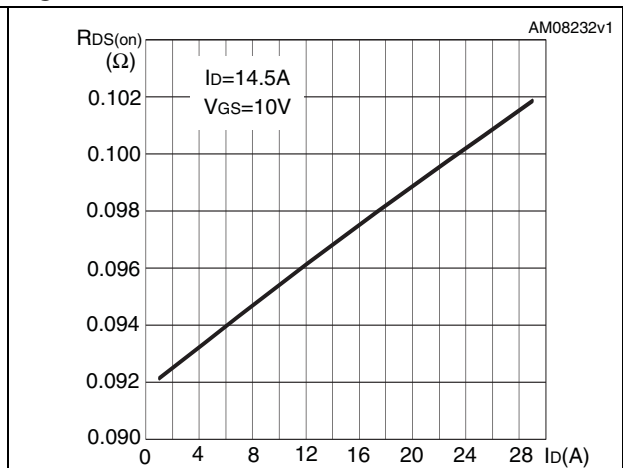

Figure 12. Capacitance variations

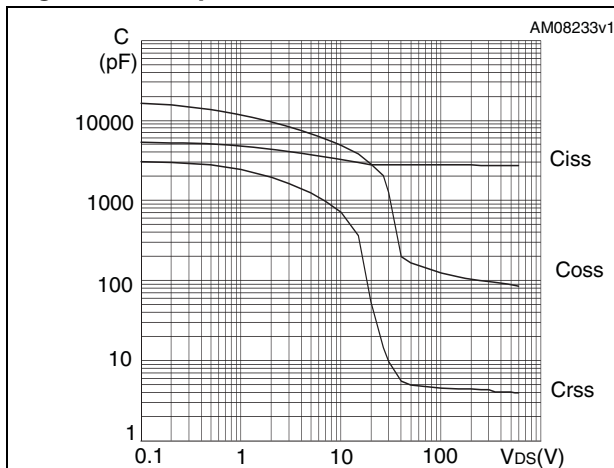

Figure 13. Output capacitance stored energy

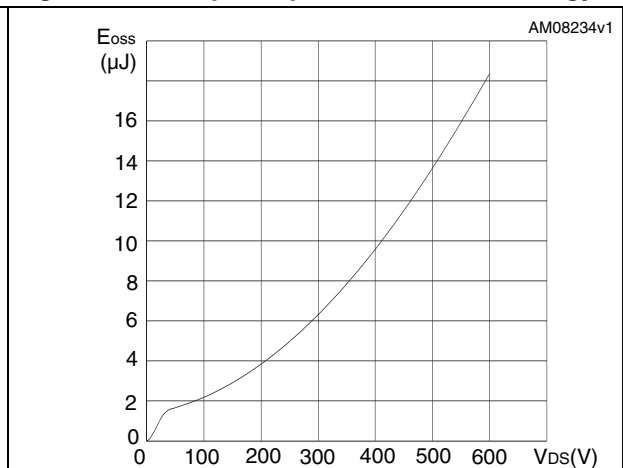

Figure 14. Normalized gate threshold voltage vs temperature

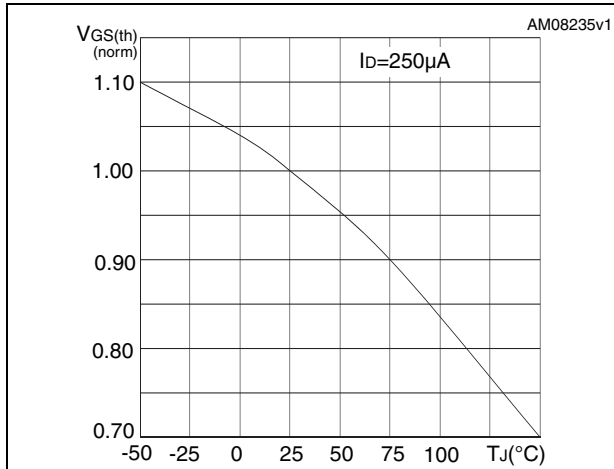

Figure 15. Normalized on resistance vs temperature

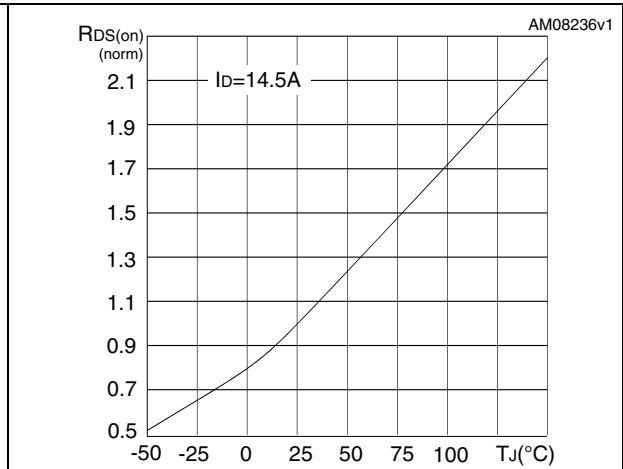

Figure 16. Normalized  $B_{VDSS}$  vs temperature

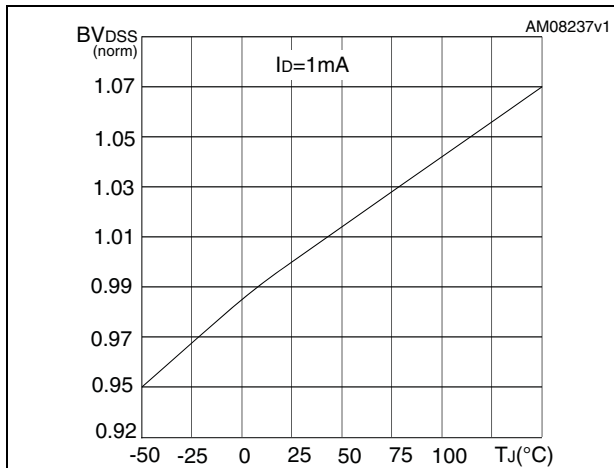
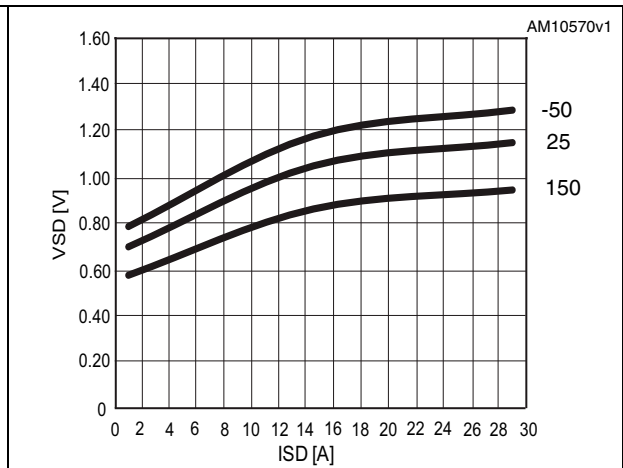

Figure 17. Source-drain diode forward vs temperature





### 3 Test circuits

**Figure 18. Switching times test circuit for resistive load**



**Figure 19. Gate charge test circuit**

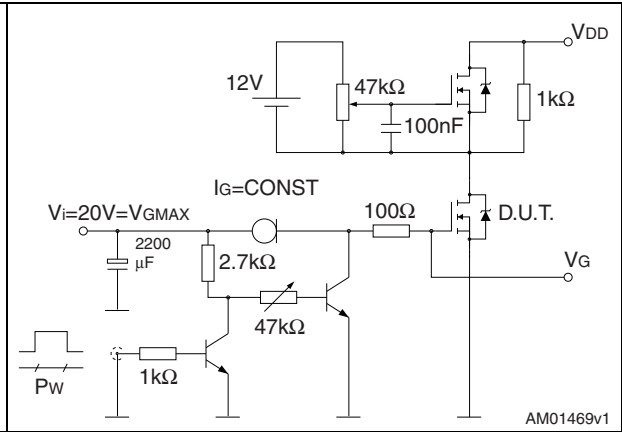

**Figure 20. Test circuit for inductive load switching and diode recovery times**

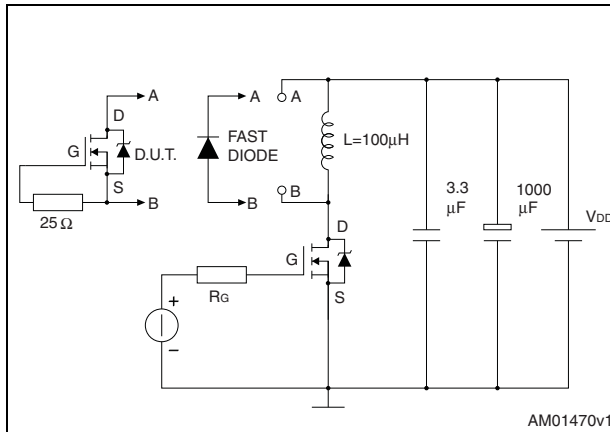

**Figure 21. Unclamped inductive load test circuit**

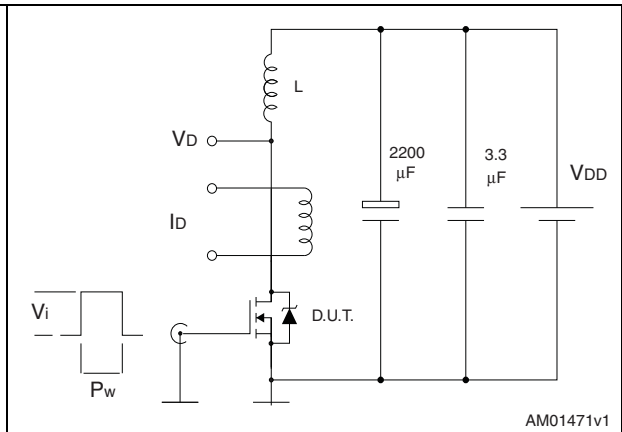

**Figure 22. Unclamped inductive waveform**

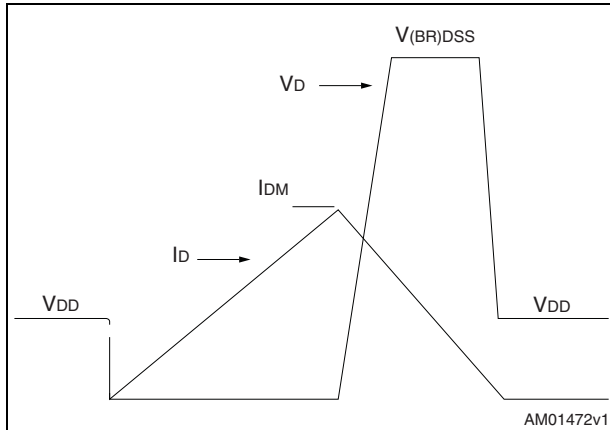

**Figure 23. Switching time waveform**

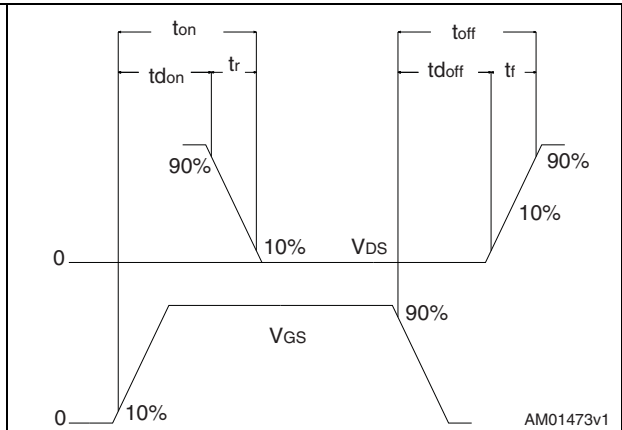

## 4 Package mechanical data

In order to meet environmental requirements, ST offers these devices in different grades of ECOPACK® packages, depending on their level of environmental compliance. ECOPACK® specifications, grade definitions and product status are available at: [www.st.com](http://www.st.com). ECOPACK® is an ST trademark.

Table 8. D<sup>2</sup>PAK (TO-263) mechanical data

Dim.	mm		
	Min.	Typ.	Max.
A	4.40		4.60
A1	0.03		0.23
b	0.70		0.93
b2	1.14		1.70
c	0.45		0.60
c2	1.23		1.36
D	8.95		9.35
D1	7.50		
E	10		10.40
E1	8.50		
e		2.54	
e1	4.88		5.28
H	15		15.85
J1	2.49		2.69
L	2.29		2.79
L1	1.27		1.40
L2	1.30		1.75
R		0.4	
V2	0°		8°

Figure 24. D<sup>2</sup>PAK (TO-263) drawing

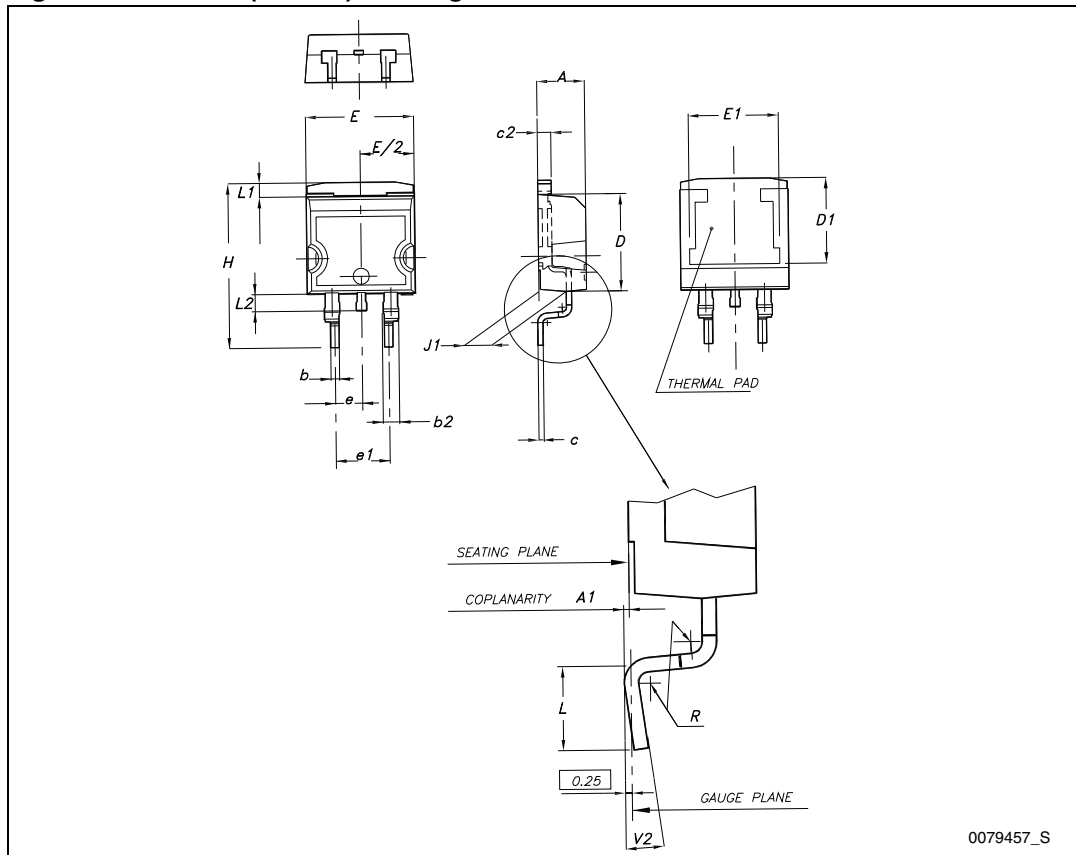
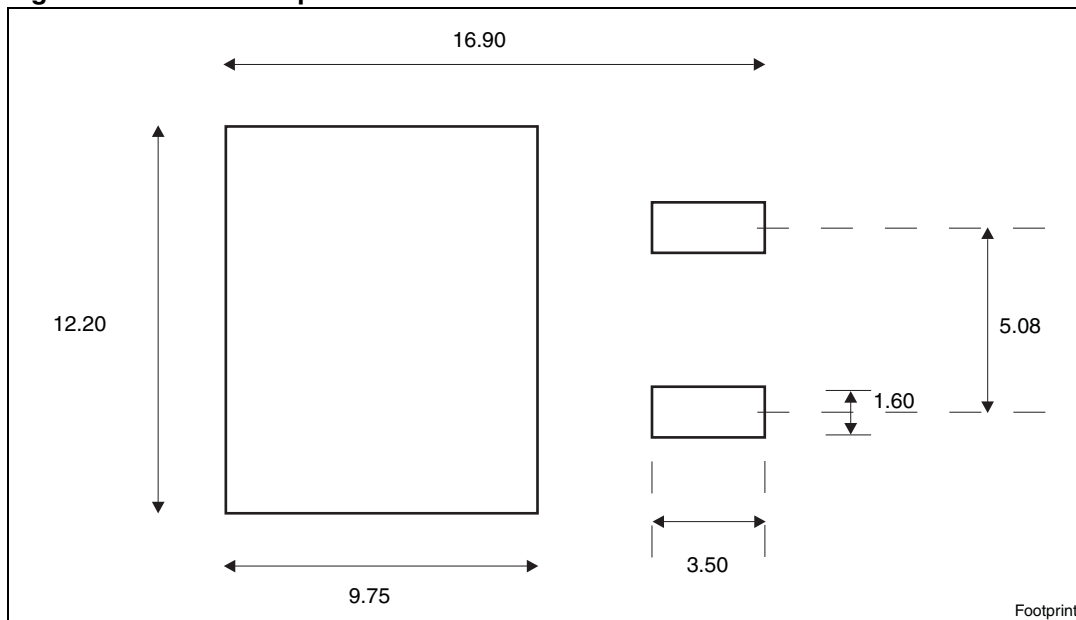

Figure 25. D<sup>2</sup>PAK footprint<sup>(a)</sup>



a. All dimension are in millimeters

Table 9. TO-220FP mechanical data

Dim.	mm		
	Min.	Typ.	Max.
A	4.4		4.6
B	2.5		2.7
D	2.5		2.75
E	0.45		0.7
F	0.75		1
F1	1.15		1.70
F2	1.15		1.70
G	4.95		5.2
G1	2.4		2.7
H	10		10.4
L2		16	
L3	28.6		30.6
L4	9.8		10.6
L5	2.9		3.6
L6	15.9		16.4
L7	9		9.3
Dia	3		3.2

Figure 26. TO-220FP drawing

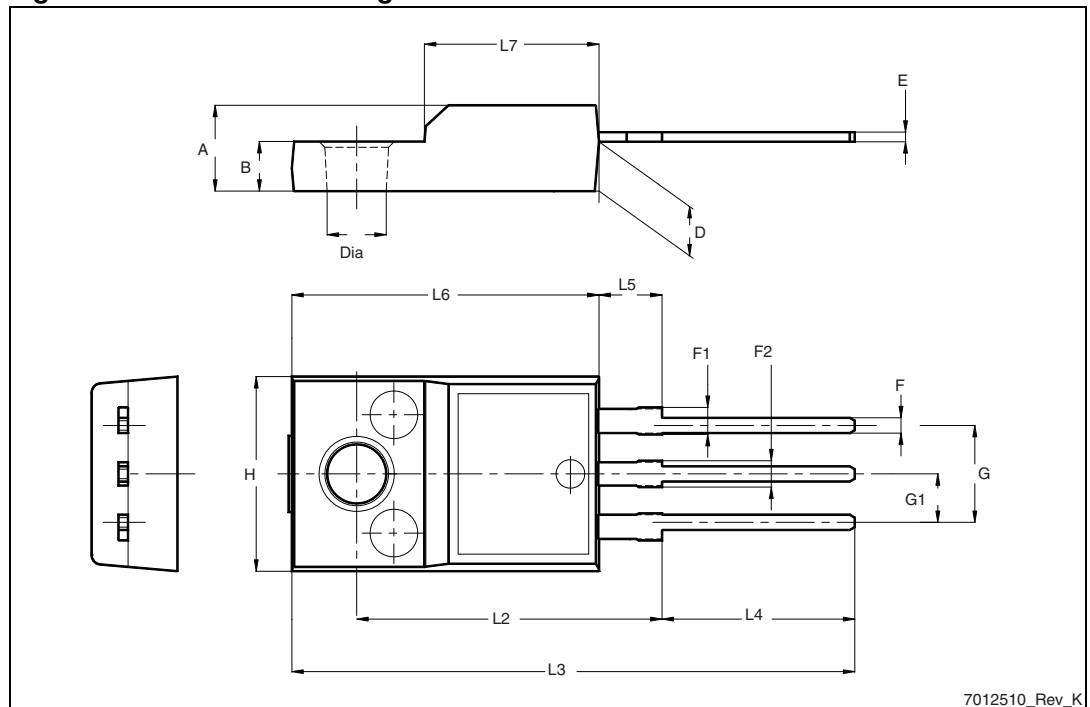

Table 10. TO-220 type A mechanical data

Dim.	mm		
	Min.	Typ.	Max.
A	4.40		4.60
b	0.61		0.88
b1	1.14		1.70
c	0.48		0.70
D	15.25		15.75
D1		1.27	
E	10		10.40
e	2.40		2.70
e1	4.95		5.15
F	1.23		1.32
H1	6.20		6.60
J1	2.40		2.72
L	13		14
L1	3.50		3.93
L20		16.40	
L30		28.90	
ØP	3.75		3.85
Q	2.65		2.95

Figure 27. TO-220 type A drawing

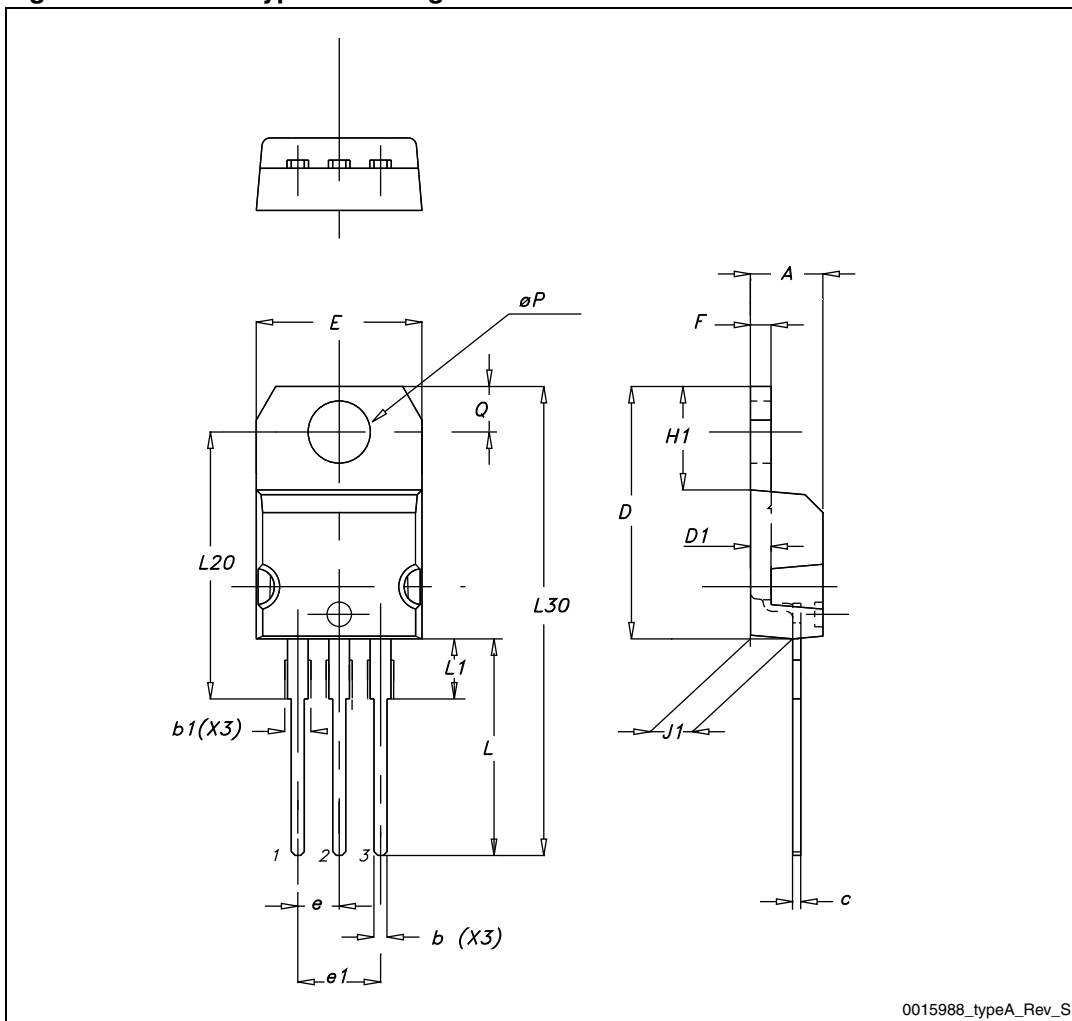
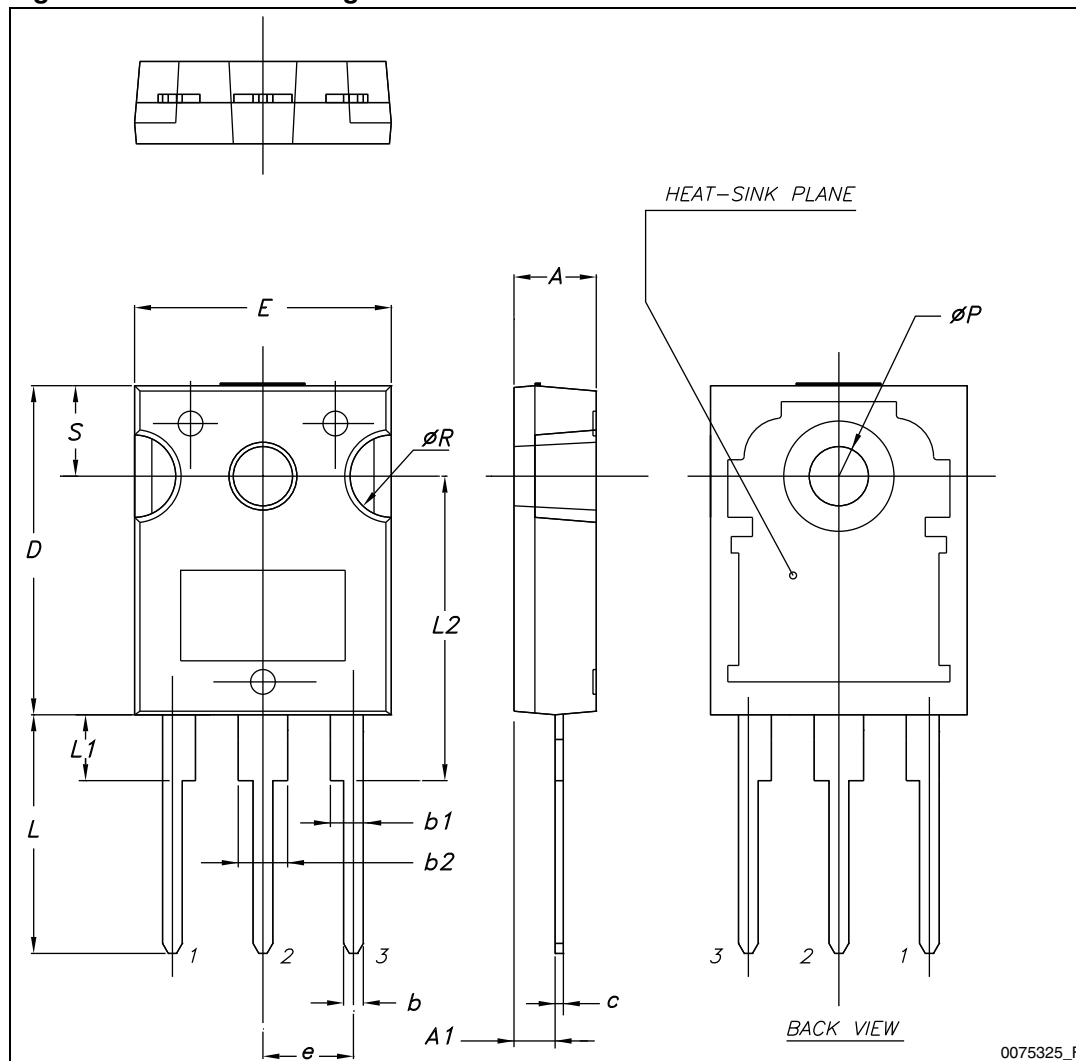

Table 11. TO-247 mechanical data

Dim.	mm		
	Min.	Typ.	Max.
A	4.85		5.15
A1	2.20		2.60
b	1.0		1.40
b1	2.0		2.40
b2	3.0		3.40
c	0.40		0.80
D	19.85		20.15
E	15.45		15.75
e		5.45	
L	14.20		14.80
L1	3.70		4.30
L2		18.50	
ØP	3.55		3.65
ØR	4.50		5.50
S		5.50	



Figure 28. TO-247 drawing



## 5 Packaging mechanical data

Table 12. D<sup>2</sup>PAK (TO-263) tape and reel mechanical data

Tape			Reel		
Dim.	mm		Dim.	mm	
	Min.	Max.		Min.	Max.
A0	10.5	10.7	A		330
B0	15.7	15.9	B	1.5	
D	1.5	1.6	C	12.8	13.2
D1	1.59	1.61	D	20.2	
E	1.65	1.85	G	24.4	26.4
F	11.4	11.6	N	100	
K0	4.8	5.0	T		30.4
P0	3.9	4.1			
P1	11.9	12.1	Base qty		1000
P2	1.9	2.1	Bulk qty		1000
R	50				
T	0.25	0.35			
W	23.7	24.3			

Figure 29. Tape

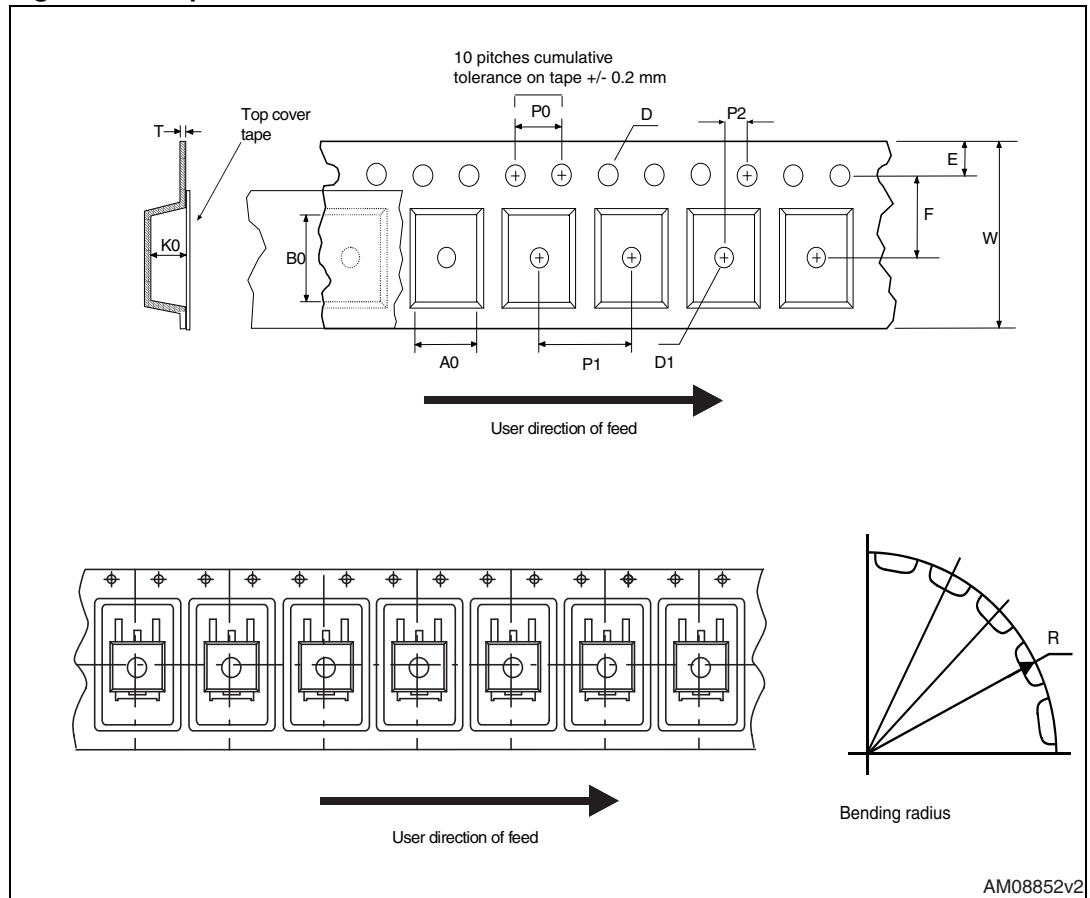

AM08852v2

Figure 30. Reel

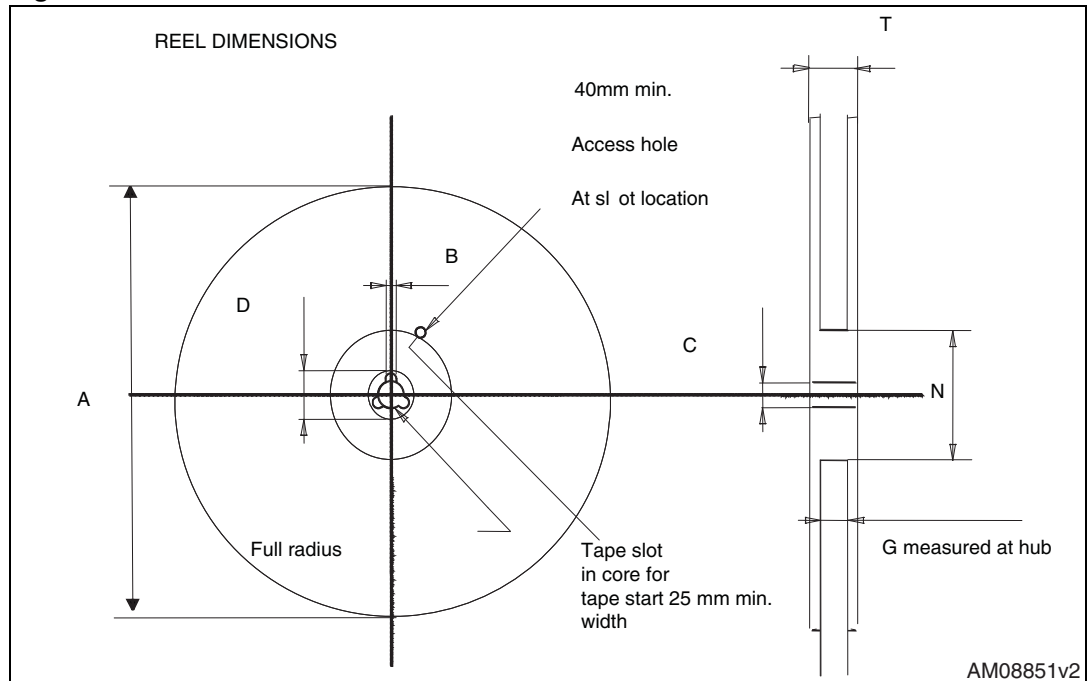

AM08851v2

## 6 Revision history

**Table 13. Document revision history**

Date	Revision	Changes
04-Nov-2010	1	Initial release.
18-Apr-2011	2	Corrected E <sub>AS</sub> value in <a href="#">Table 4: Avalanche characteristics</a>
14-Sep-2011	3	Added order code in D <sup>2</sup> PAK and TO-220FP Updated <a href="#">Table 1: Device summary</a> , <a href="#">Table 2: Absolute maximum ratings</a> and <a href="#">Table 3: Thermal data</a> . Updated <a href="#">Section 4: Package mechanical data</a> . Added <a href="#">Section 5: Packaging mechanical data</a> . Minor text changes.
29-Dec-2011	4	Updated description in cover page.

**Please Read Carefully:**

Information in this document is provided solely in connection with ST products. STMicroelectronics NV and its subsidiaries ("ST") reserve the right to make changes, corrections, modifications or improvements, to this document, and the products and services described herein at any time, without notice.

All ST products are sold pursuant to ST's terms and conditions of sale.

Purchasers are solely responsible for the choice, selection and use of the ST products and services described herein, and ST assumes no liability whatsoever relating to the choice, selection or use of the ST products and services described herein.

No license, express or implied, by estoppel or otherwise, to any intellectual property rights is granted under this document. If any part of this document refers to any third party products or services it shall not be deemed a license grant by ST for the use of such third party products or services, or any intellectual property contained therein or considered as a warranty covering the use in any manner whatsoever of such third party products or services or any intellectual property contained therein.

**UNLESS OTHERWISE SET FORTH IN ST'S TERMS AND CONDITIONS OF SALE ST DISCLAIMS ANY EXPRESS OR IMPLIED WARRANTY WITH RESPECT TO THE USE AND/OR SALE OF ST PRODUCTS INCLUDING WITHOUT LIMITATION IMPLIED WARRANTIES OF MERCHANTABILITY, FITNESS FOR A PARTICULAR PURPOSE (AND THEIR EQUIVALENTS UNDER THE LAWS OF ANY JURISDICTION), OR INFRINGEMENT OF ANY PATENT, COPYRIGHT OR OTHER INTELLECTUAL PROPERTY RIGHT.**

**UNLESS EXPRESSLY APPROVED IN WRITING BY TWO AUTHORIZED ST REPRESENTATIVES, ST PRODUCTS ARE NOT RECOMMENDED, AUTHORIZED OR WARRANTED FOR USE IN MILITARY, AIR CRAFT, SPACE, LIFE SAVING, OR LIFE SUSTAINING APPLICATIONS, NOR IN PRODUCTS OR SYSTEMS WHERE FAILURE OR MALFUNCTION MAY RESULT IN PERSONAL INJURY, DEATH, OR SEVERE PROPERTY OR ENVIRONMENTAL DAMAGE. ST PRODUCTS WHICH ARE NOT SPECIFIED AS "AUTOMOTIVE GRADE" MAY ONLY BE USED IN AUTOMOTIVE APPLICATIONS AT USER'S OWN RISK.**

Resale of ST products with provisions different from the statements and/or technical features set forth in this document shall immediately void any warranty granted by ST for the ST product or service described herein and shall not create or extend in any manner whatsoever, any liability of ST.

ST and the ST logo are trademarks or registered trademarks of ST in various countries.

Information in this document supersedes and replaces all information previously supplied.

The ST logo is a registered trademark of STMicroelectronics. All other names are the property of their respective owners.

© 2011 STMicroelectronics - All rights reserved

STMicroelectronics group of companies

Australia - Belgium - Brazil - Canada - China - Czech Republic - Finland - France - Germany - Hong Kong - India - Israel - Italy - Japan - Malaysia - Malta - Morocco - Philippines - Singapore - Spain - Sweden - Switzerland - United Kingdom - United States of America

[www.st.com](http://www.st.com)