

Miniature Laser Photoelectric Switches (Built-in Amplifier)

SA1E-L

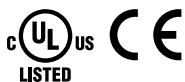

Visible red laser beam and fast response speed. High precision sensing.



• See website for details on approvals and standards.



Through-beam



Polarized Retroreflective



Background Suppression (BGS)

Easy-to-align optical axis

Because the optical axis can be positioned quickly, the photoelectric switch can be installed on a machine or system easily, even in applications requiring a long sensing range or detection of small objects.

Detects fast-moving objects

The 250 μ s response speed is the fastest in its class. Closely-spaced objects on a fast-moving conveyor can be detected reliably.

Easy positionig

Because the visible red laser is easy to see in both short (20 mm) and long (30 m) distances, the detecting position and optical axis can be found quickly. The small beam can detect small objects, and it also enables easy positioning of the sensor in applications where the beam has to pass through narrow spaces.

All models are Class 1 laser compliant (JIS, IEC, FDA).



Dust and water resistant

IP67 structure can be used in environments exposed to dust or water vapor.

Selectable modes

Light ON/Dark ON



SA1E-L Miniature Laser Photoelectric Switches (Built-in Amplifier)

Package Quantity: 1

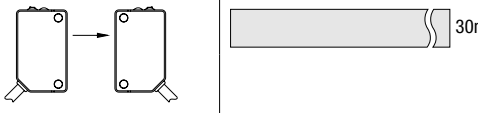
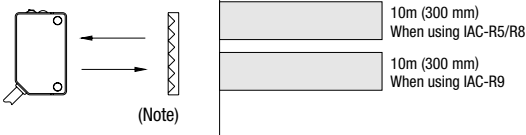
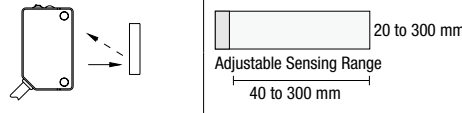
Sensing Method	Sensing Range	Connection	Cable Length	Part No.	
				NPN Output	PNP Output
Through-beam	 See the characteristics on M-025 .	Cable	1 m	SA1E-LTN3	SA1E-LTP3
			2 m	SA1E-LTN3-2M	SA1E-LTP3-2M
			5 m	SA1E-LTN3-5M	SA1E-LTP3-5M
		Connector	—	SA1E-LTN3C	SA1E-LTP3C
Polarized Retroreflective	 See the characteristics on M-025 .	Cable	1 m	SA1E-LPN3	SA1E-LPP3
			2 m	SA1E-LPN3-2M	SA1E-LPP3-2M
			5 m	SA1E-LPN3-5M	SA1E-LPP3-5M
		Connector	—	SA1E-LPN3C	SA1E-LPP3C
Background Suppression	 See the characteristics on M-026 .	Cable	1 m	SA1E-LBN3	SA1E-LBP3
			2 m	SA1E-LBN3-2M	SA1E-LBP3-2M
			5 m	SA1E-LBN3-5M	SA1E-LBP3-5M
		Connector	—	SA1E-LBN3C	SA1E-LBP3C

Note: Maintain at least the distance shown in the () between the SA1E-L photoelectric switch and reflector.
 Reflectors are not supplied and must be ordered separately. See **M-027**.

- APEM
- Switches & Pilot Lights
- Control Boxes
- Emergency Stop Switches
- Enabling Switches
- Safety Products
- Explosion Proof
- Terminal Blocks
- Relays & Sockets
- Circuit Protectors
- Power Supplies
- LED Illumination
- Controllers
- Operator Interfaces
- Sensors**
- AUTO-ID
- SA1E
- SA1E-L



SA1E-L Miniature Laser Photoelectric Switches (Built-in Amplifier)

Specifications

	Through-beam	Polarized Retroreflective	Background Suppression (BGS)
Part No.	SA1E-LT	SA1E-LP	SA1E-LB
Power Voltage	12 to 24V DC (Operating range: 10 to 30V DC) Equipped with reverse-polarity protection		
Current Draw	Projector: 15 mA maximum Receiver: 30 mA maximum	35 mA maximum	
Sensing Range	30m	0.3 to 10m (IAC-R5/R8/R9)	20 to 300 mm (using 100 × 100 mm white matte paper)
Adjustable Sensing Range	—		40 to 300 mm
Detectable Object Size (typical)	ø6 mm minimum (opaque, at 3 m)		ø0.2 mm minimum (copper wire) (at 170 mm)
Detectable Object	Opaque		
Hysteresis	—		10% maximum
Response Time	250 µs maximum		
Sensitivity Adjustment	Adjustable using a potentiometer		—
Sensing Range Adjustment	—		6-turn control knob
Light Source Element	Red laser diode (emission wavelength: 650 nm) (IEC/JIS/FDA Class 1) (Note)		
Operation Mode	Light ON/Dark ON (selectable)		
Control Output	NPN open collector or PNP open collector (30V DC, 100 mA maximum, short-circuit protection) Voltage drop: 1.5V maximum		
LED Indicators	Operation LED: Yellow Stable LED: Green Power LED: Green (Through-beam type projector)		
Interference Prevention	—		Two units can be mounted in close proximity.
Degree of Protection	IP67 (IEC 60529)		
Extraneous Light Immunity	Sunlight: 10,000 lux maximum, Incandescent lamp: 5,000 lux maximum (at receiver)		
Operating Temperature	-10 to +55°C (no freezing)		
Operating Humidity	35 to 85% RH (no condensation)		
Storage Temperature	-25 to +70°C (no freezing)		
Storage Humidity	35 to 85% RH (no condensation)		
Insulation Resistance	Between live part and mounting bracket: 20 MΩ minimum (500V DC megger)		
Dielectric Strength	Cable models: 1,000V AC, 50/60 Hz, 1 minute (between live part and mounting bracket) Connector models when connected with connector cable: 500V AC, 50/60 Hz, 1 minute (between live part and clamp ring)		
Vibration Resistance	10 to 55 Hz, amplitude 1.5 mm, 20 cycles in each of 3 axes		
Shock Resistance	500 m/s ² , 3 shocks in each of 3 axes		
Material	Housing: PBT, Lens: PMMA, Indicator cover: PC, knob; POM		
Weight (approx.)	Cable Model	35g (1 m cable), 55g (2 m cable), 120g (5 m cable)	
	Connector Model	20g	
Connection Method	Cable Model	ø3.5 mm, 3-core, 0.2 mm ² , vinyl cabtyre cable	
	Connector Model	M8 connector (4-pin)	

Note: Compliant with Class 1 of FDA regulations (21 CFR 1040.10 and 21 CFR 1040.11 according to Laser Notice No. 50).

Slit and Sensing Range (typical) [Through-beam SA1E-LT□]

Slit		Sensing Range (m)	Minimum Detectable Object Width (mm)
Part No.	Slit Width: A	Used on receiver	
SA9Z-S12	0.5 mm	6	11
SA9Z-S13	1.0 mm	10	1.6
SA9Z-S14	2.0 mm	22	2.5

- Minimum detectable object width (mm): when the object is at the intermediate point between the projector and receiver.

The slit can be pressed to snap onto the front easily.

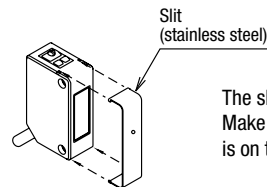

The slits have an orientation. Make sure that the TOP marking is on top of the sensor (LED side).

Dimensions

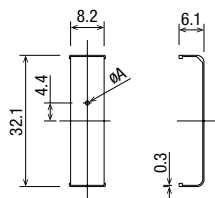

Material: Stainless Steel
All dimensions in mm.

Dimensions

All dimensions in mm

SENSORS

- APEM
- Switches & Pilot Lights
- Control Boxes
- Emergency Stop Switches
- Enabling Switches
- Safety Products
- Explosion Proof
- Terminal Blocks
- Relays & Sockets
- Circuit Protectors
- Power Supplies
- LED Illumination
- Controllers
- Operator Interfaces
- Sensors
- AUTO-ID

Cable Model

- Through-beam
- Polarized Retroreflective
- Background Suppression (BGS)

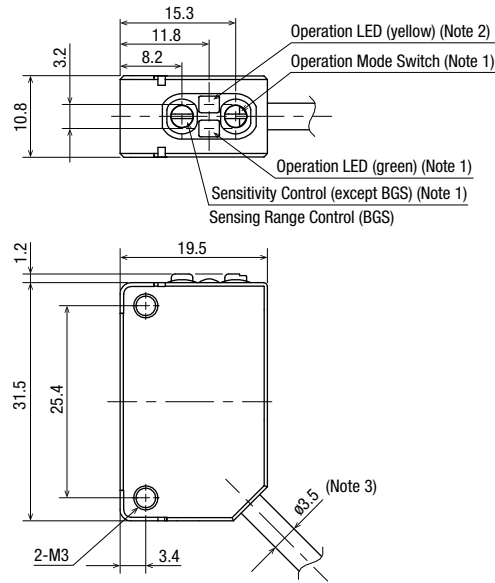
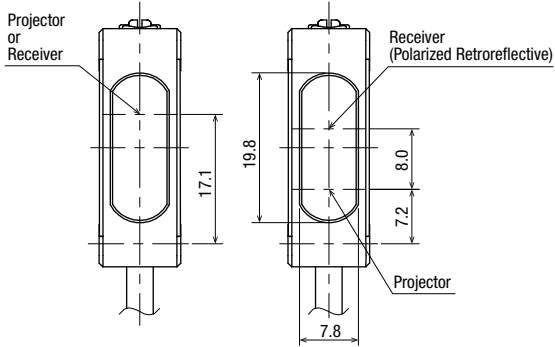

Connector Model

- Through-beam
- Polarized Retroreflective
- Background Suppression (BGS)

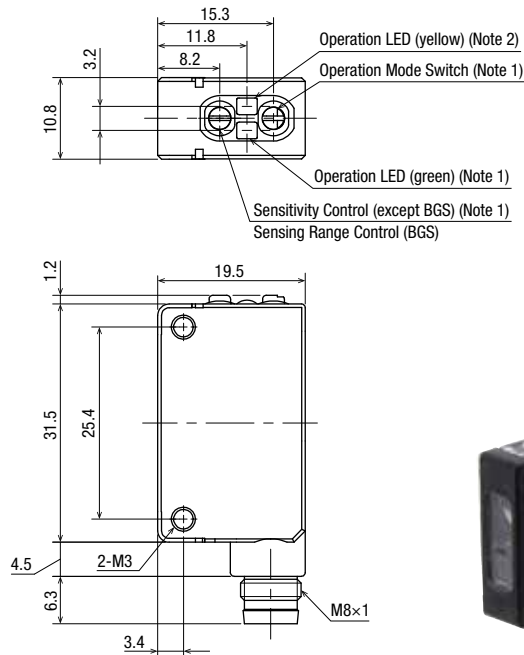
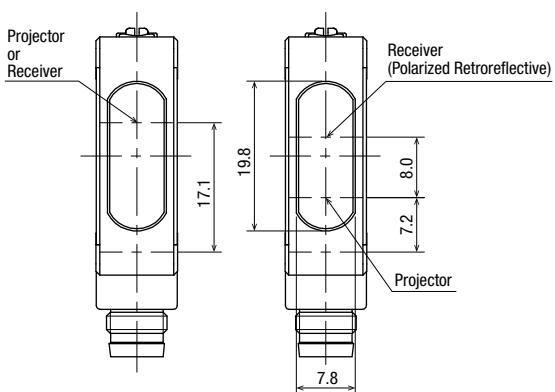

In the photo, the right-angle connector cable is attached.

Note 1: No stable LED, sensitivity control, and operation mode switch are attached on the through-beam projector.
 Note 2: Power ON LED (green) for through-beam projector.
 Note 3: Cable length depends on models.
 Note 4: The connector length is 18 mm when a right-angle connector cable (SA9Z-CM8K-4L*) is attached.

Output Circuit & Wiring Diagram

NPN Output

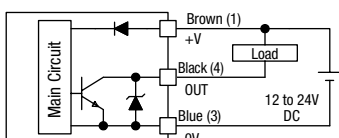

(Connector Pin Assignment)

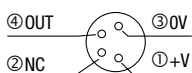

PNP Output

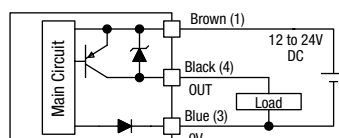

(Connector Pin Assignment)

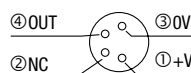

Through-beam Type Projector

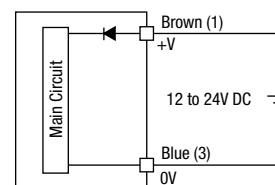

(Connector Pin Assignment)

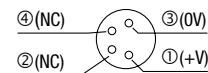

Characteristics (Typical)

1. Through-beam SA1E-LT

Excess Gain (without slit)

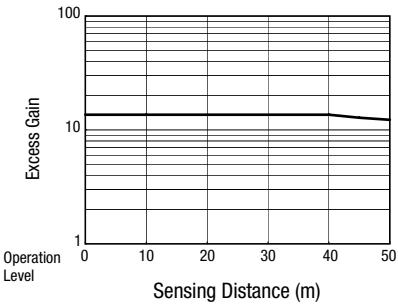

Excess Gain (with round slit)

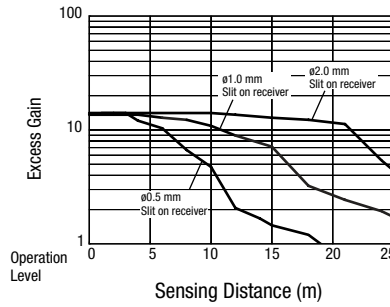

Lateral Displacement (without slit)

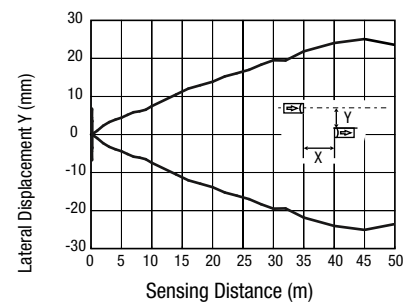

Angle (without slit)

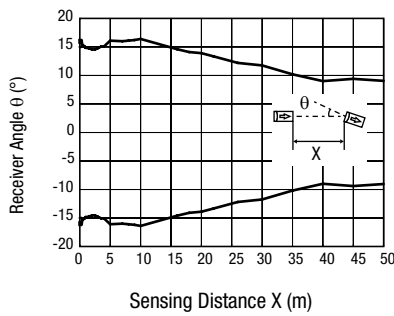

Light Beam Diameter

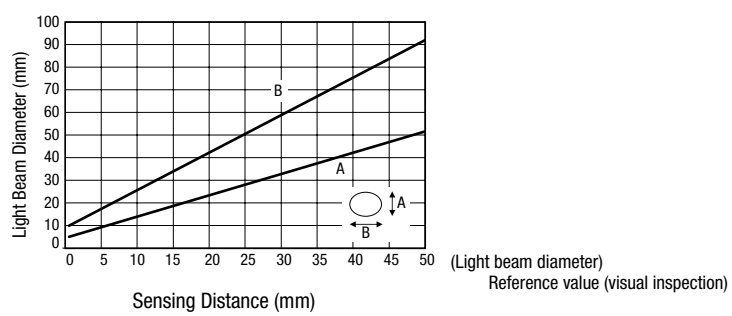

2. Polarized Retroreflective SA1E-LP

Excess Gain

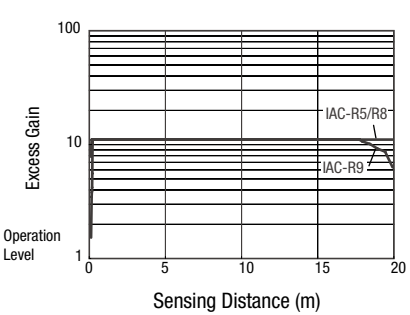

Lateral Displacement

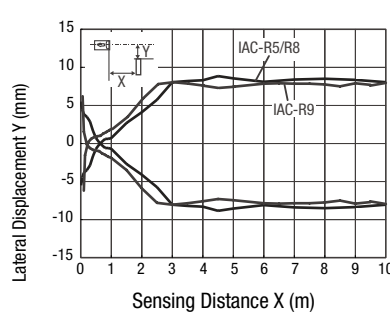

Angle

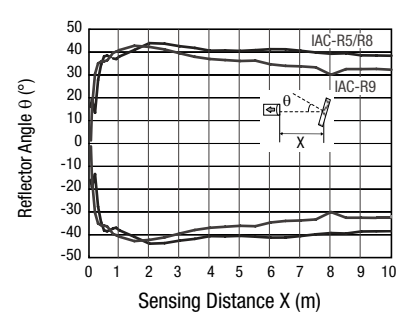

Light Beam Diameter

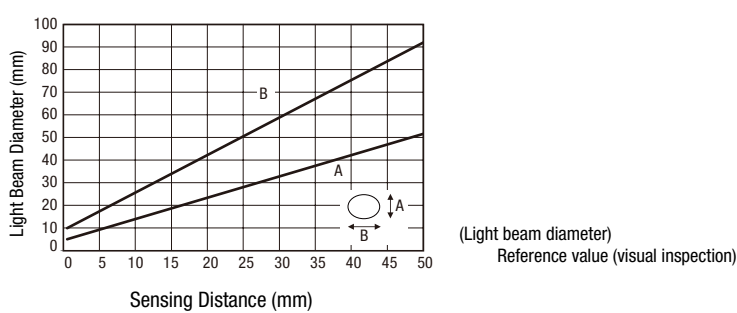

Characteristics (Typical)

3. Background Suppression (BGS) SA1E-LB

Lateral Displacement (Preset 150 mm)

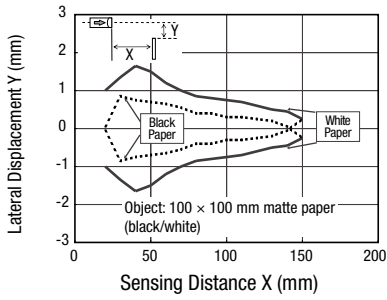

Lateral Displacement (Preset 300 mm)

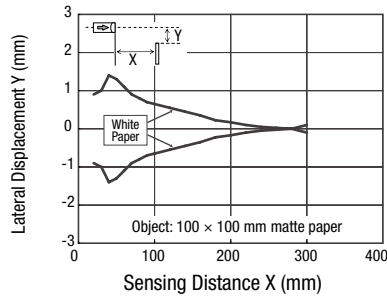

Light Beam Diameter

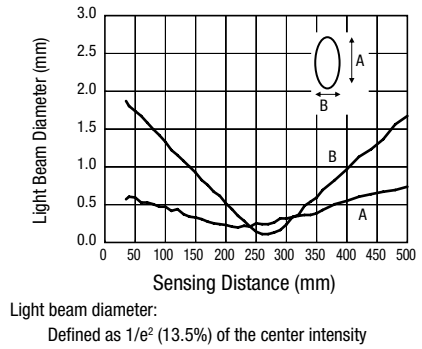

Color Matte Paper and Other Materials (Preset 150 mm)

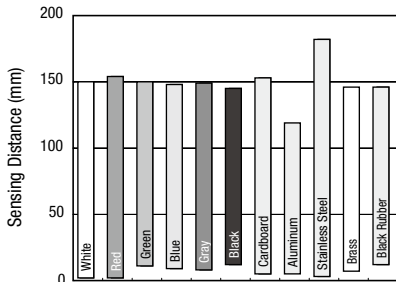

Comparison of sensing distance when set to detect white matte paper (100 × 100 mm) at 150 mm

Color Matte Paper and Other Materials (Preset 300 mm)

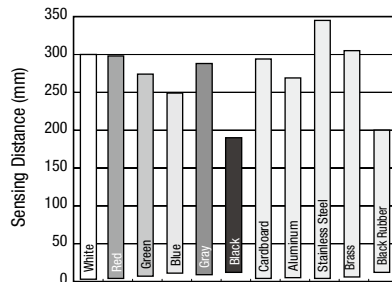

Comparison of sensing distance when set to detect white matte paper (100 × 100 mm) at 300 mm

Control Knob vs. Sensing Distance

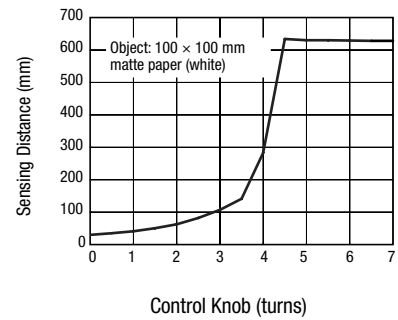

- APEM
- Switches & Pilot Lights
- Control Boxes
- Emergency Stop Switches
- Enabling Switches
- Safety Products
- Explosion Proof
- Terminal Blocks
- Relays & Sockets
- Circuit Protectors
- Power Supplies
- LED Illumination
- Controllers
- Operator Interfaces
- Sensors
- AUTO-ID

SA1E

SA1E-L



SA1E-L Miniature Laser Photoelectric Switches (Built-in Amplifier)

Accessories (optional)

Slits (for through-beam)

When ordering, specify the Ordering No.

Item	Slit Size	Part No.	Ordering No.	Package Quantity
Round Slit	ø0.5 mm	SA9Z-S12	SA9Z-S12PN02	2
	ø1.0 mm	SA9Z-S13	SA9Z-S13PN02	
	ø2.0 mm	SA9Z-S14	SA9Z-S14PN02	

- See **M-023** for dimensions.

Reflectors

Item	Part No.	Package Quantity
Reflector	IAC-R5	1
	IAC-R8	
	IAC-R9	

- See **M-029** for dimensions.

Reflector Mounting Brackets

Item	Part No.	Package Quantity	
Reflector Mounting Bracket	For IAC-R5	IAC-L2 (Note 1)	1
	For IAC-R9	IAC-L3 (Note 2)	
	For IAC-R8	IAC-L5 (Note 3)	

- See **M-030** for dimensions.

Note 1: The IAC-L2 is not supplied with M4 mounting screws and nuts.

Note 2: The IAC-L3 is supplied with two M3 mounting screws (M3 × 8 mm sems screws).

Note 3: The IAC-L5 is supplied with two M4 mounting screws (M4 × 10 mm sems screws).

Sensor Mounting Brackets

Item	Part No.	Package Quantity	
Sensor Mounting Brackets	Vertical Mounting	SA9Z-K01	1
	Horizontal Mounting	SA9Z-K02	
	Cover Type	SA9Z-K03	
	Back Mounting	SA9Z-K04	

- See **M-028** for dimensions.
- Two mounting screws (M3 × 12 mm sems screws) are supplied with the SA9Z-K01 and SA9Z-K02.
- Two mounting screws (M3 × 14 mm sems screws) are supplied with the SA9Z-K03.
- The through-beam type requires two mounting brackets, one each for the projector and the receiver.
- The SA9Z-K02 cannot be used for the connector models.
- Contact IDEC about mounting brackets for the connector models.

Air Blower Mounting Block

Item	Part No.	Package Quantity
Air Blower Mounting Block	SA9Z-A02	1

- See **M-030** for dimensions.
- Two mounting screws (M3 × 20 mm sems screws), one M5 × 6 mm screw for plugging the air supply port, and one gasket (0.5 mm thick) are supplied.
- The air tube fitting and mounting bracket are not supplied and must be ordered separately (recommended mounting bracket: SA9Z-K01).
- Material: Anodized aluminum surface

Connector Cable (for connector models)

Number of Core Wires	Style & Length	Part No.	Package Quantity
4	Straight, 2m	SA9Z-CM8K-4S2	1
	Straight, 5m	SA9Z-CM8K-4S5	
	Right angle, 2m	SA9Z-CM8K-4L2	
	Right angle, 5m	SA9Z-CM8K-4L5	

- See **M-030** for dimensions.
- Contact IDEC for UL approved cables.

Sensitivity Control Screwdriver

Item	Part No.	Package Quantity
Sensitivity Control Screwdriver	SA9Z-AD01	1



Dimensions

All dimensions in mm

Sensor Mounting Brackets

SA9Z-K01

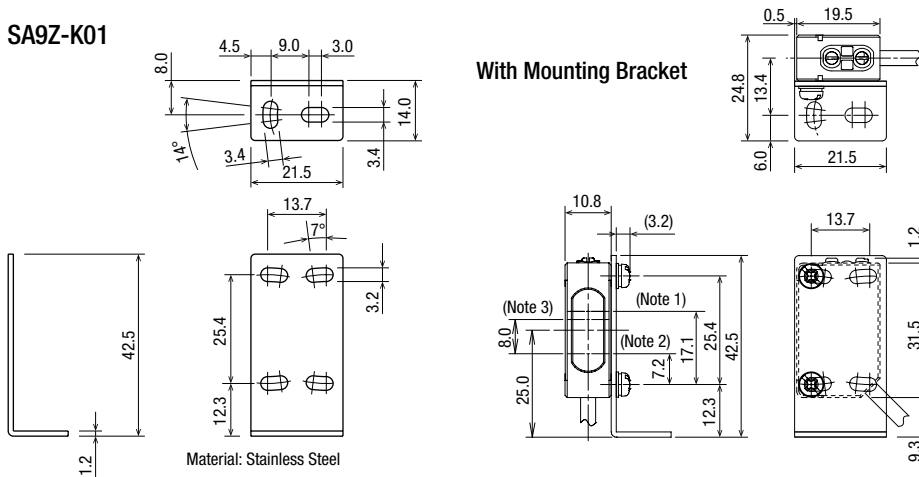

With Mounting Bracket

- Note 1: Projector (through-beam)
Receiver (through-beam)
- Note 2: Projector (polarized retroreflective,
background suppression)
- Note 3: Receiver (polarized retroreflective)

SA9Z-K02

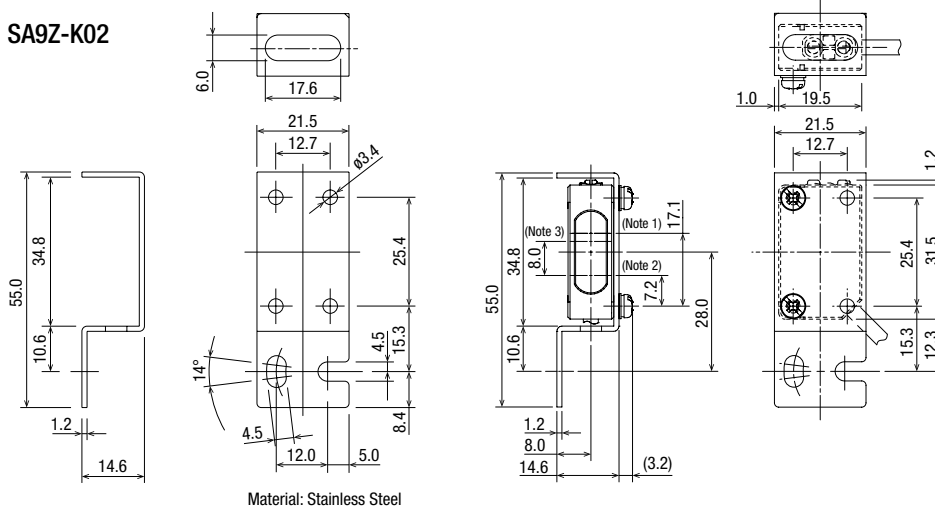

- Note 1: Projector (through-beam)
Receiver (through-beam)
- Note 2: Projector (polarized retroreflective,
background suppression)
- Note 3: Receiver (polarized retroreflective)

SA9Z-K03

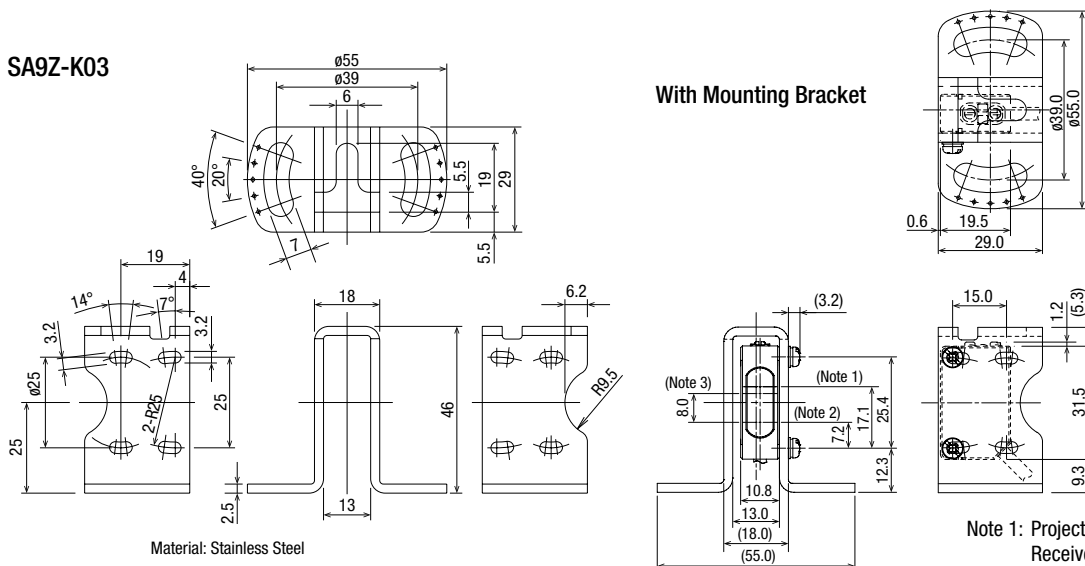

With Mounting Bracket

- Note 1: Projector (through-beam)
Receiver (through-beam)
- Note 2: Projector (polarized retroreflective,
background suppression)
- Note 3: Receiver (polarized retroreflective)

- APEM
- Switches & Pilot Lights
- Control Boxes
- Emergency Stop Switches
- Enabling Switches
- Safety Products
- Explosion Proof
- Terminal Blocks
- Relays & Sockets
- Circuit Protectors
- Power Supplies
- LED Illumination
- Controllers
- Operator Interfaces
- Sensors
- AUTO-ID
- SA1E
- SA1E-L

SA1E-L Miniature Laser Photoelectric Switches (Built-in Amplifier)

Dimensions

All dimensions in mm

SA9Z-K04

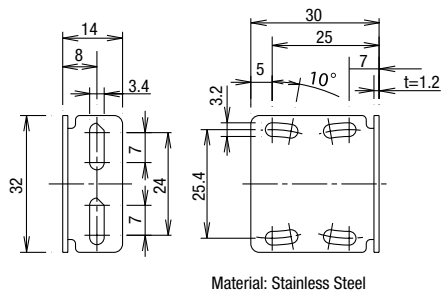

With Mounting Bracket

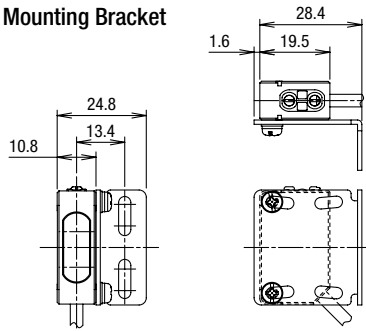

Reflector

IAC-R5

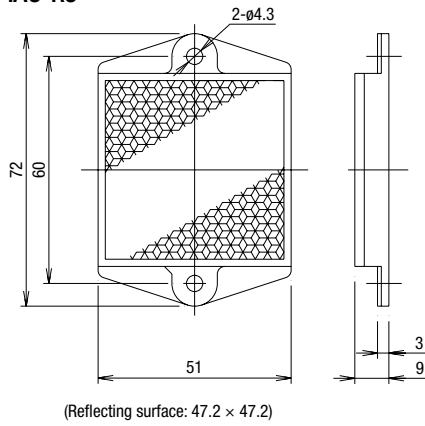

IAC-R8

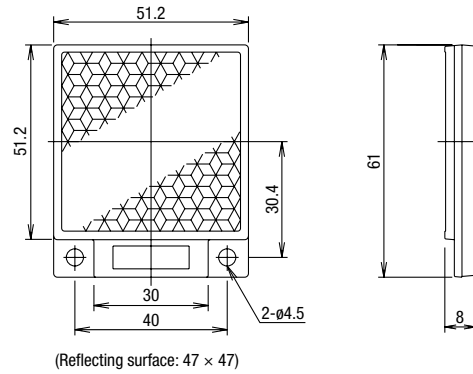

IAC-R9

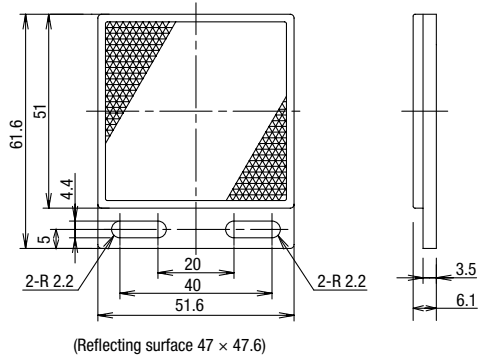

SA1E

SA1E-L

- APEM
- Switches & Pilot Lights
- Control Boxes
- Emergency Stop Switches
- Enabling Switches
- Safety Products
- Explosion Proof
- Terminal Blocks
- Relays & Sockets
- Circuit Protectors
- Power Supplies
- LED Illumination
- Controllers
- Operator Interfaces
- Sensors
- AUTO-ID

Accessory Dimensions

All dimensions in mm

Reflector Mounting Brackets

IAC-L2 (for IAC-R5)

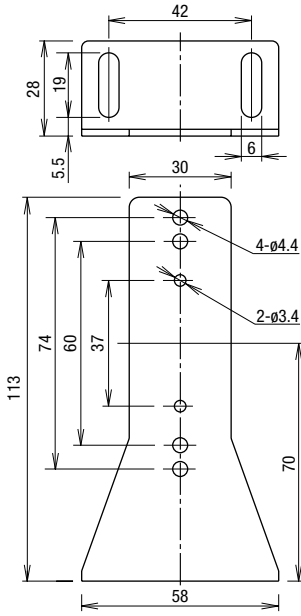

IAC-L3 (for IAC-R9)

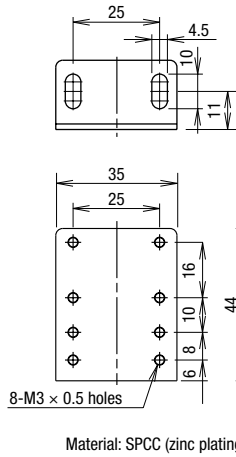

IAC-L5 (for IAC-R8)

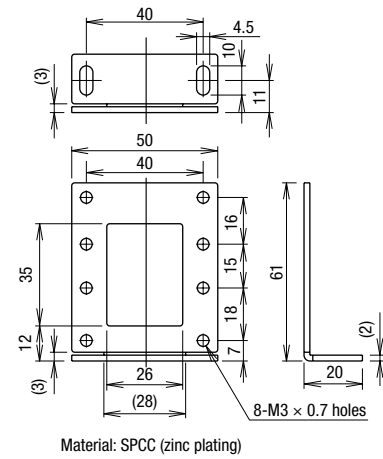

Connector Cable (connector on one end)

Straight (SA9Z-CM8K-4S□)

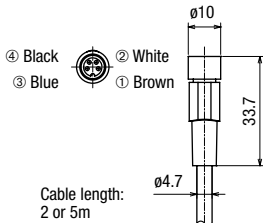

Right-angle (SA9Z-CM8K-4L□)

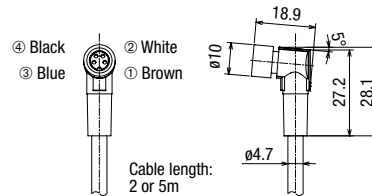

- Dielectric strength when installed on the SA1E-L: 1000V AC (between live part and mounting bracket, except between live part and tightening ring)

Air Blower Mounting Block

SA9Z-A02

With Mounting Bracket

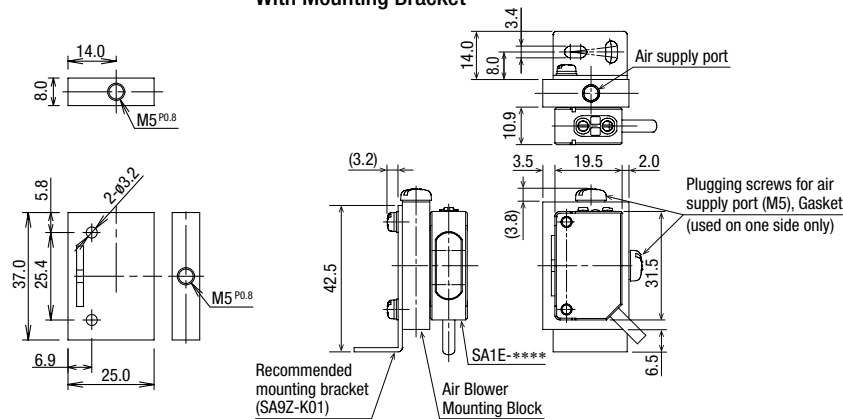

(Material: Anodized aluminum surface)

- The SA9Z-A02 air blower mounting block is supplied with two mounting screws (M3 × 20 mm sems screws), one screw for plugging the air supply port (M5 × 6 mm), and one gasket (1 mm thick) for plugging the air supply port.
- An air tube fitting can be installed to either the top or side. Tighten the fitting to a torque of 0.5 N·m maximum.
- The air tube fitting and mounting bracket are not supplied and must be ordered separately (recommended mounting bracket: SA9Z-K01).



Instructions

**Indicator and Output Operation
(Through-beam/Polarized Retroreflective)**

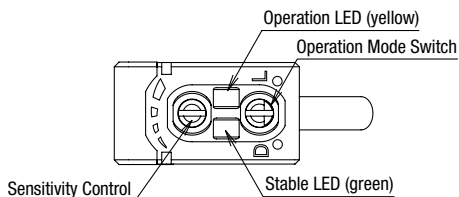

- The operation LED turns on (yellow) when the control output is on.
- The stable LED turns on (green) either at stable incident or stable interruption. Make sure to use the photoelectric switch after the stable operation is ensured.
- In the light ON operation, the output turns on when the receiving light intensity level is 1.0 or over as shown below.
- In the dark-ON operation, the output turns on when the receiving light intensity level is 1.0 or less as shown below.

Receiving Light Intensity Level	Light Receiving Status	Stable LED (green)	Operation LED (yellow)/ Control Output	
			Light ON	Dark ON
Operation Level	1.3 and over	Stable Incident	ON	OFF
	1.0	Unstable Incident	OFF	OFF
0.7 and below		Unstable Interruption	OFF	ON
		Stable Interruption	ON	ON

Optical Axis Alignment (Light ON)

Through-beam

Fasten the receiver temporarily. Place the projector to face the receiver. Move the projector up, down, right and left to find the range where the operation LED turns on. Fasten the projector in the middle of the range. Next, move the receiver up, down, right and left in the same manner and fasten in the middle of the range where the operation LED turns on. Make sure that stable LED turns on at stable incident and stable interruption.

Polarized Retroreflective

Install the reflector perpendicularly to the optical axis. Move the SA1E-L photoelectric switch up, down, right and left to find the range where the operation LED turns on. Fasten the switch in the middle of the range. Make sure that stable LED turns on at stable incident and stable interruption. When installing the reflector near the photoelectric switch, adjust the angle and positions of photoelectric switch and reflector so that sensing objects can be detected reliably.

Background Suppression (BGS)

Place the SA1E-L photoelectric switch where the switch can detect the object. Move the switch up, down, right and left to find the range where the operation LED turns on. Fasten the switch in the middle of the range. Make sure that stable LED turns on at stable incident and stable interruption.

**Sensitivity Adjustment
(Through-beam/Polarized Retroreflective)**

- Referring to the table below, adjust the sensitivity of the SA1E-L photoelectric switch when necessary, in such cases as the through-beam is used to detect small or translucent objects. The table explains the status of operation LED when the operation mode is set to light ON.

Step	Photoelectric Switch Status	Sensitivity Control	Adjusting Procedure
1	Receiving light • Through-beam, polarized retroreflective: No object detected		Turn the control counter-clockwise to the minimum. Then turn clockwise until the operation LED turns on (turns off with dark ON type) (point A).
2	Light is interrupted • Through-beam, polarized retroreflective: Object detected		At interruption status, turn the control clockwise from point A, until the operation LED turns on (turns off with dark ON type) (point B). If the operation LED does not turn on (turn off with dark ON type) even though the control has reached the maximum, set the maximum position as point B.
3	—		Set the middle point between point A and B as point C.

- After adjusting the sensitivity, make sure that stable LED turns on at stable incident and stable interruption. For detecting objects too small to turn on the stable LED, use an optional slit.
- Sensitivity is set to the maximum at the factory before shipment. When adjusting the sensitivity, use the screwdriver supplied with the SA1E-L photoelectric switch to turn the control as shown below, to a torque of 0.05 N·m maximum.

Adjustment of Sensing Range for Background Suppression (BGS)

- When adjusting the sensing range, follow the instruction below.

Step	Distance Control	Adjusting Procedure
1		Install the photoelectric switch and the object firmly. Turn the control counterclockwise until the operation LED turns off (turns on with dark ON type). From this point, turn the control clockwise until the operation LED turns on (turns off with dark ON type) (point A).
2		Remove the object, and confirm that the operation LED turns off (turns on with dark ON type). Turn the control clockwise until the operation LED turns on (detecting the background) (turns off with dark ON type) (point B). (Note 1)
3		Set the middle point between point A and B as point C. (Note 2)

Note 1: When the background is far off and not detected, turn the control 360°, and set the point as point C.

Note 2: Because the control is multi-turn, it may take more than one turn to move from point A to point B.

- Turning the control clockwise lengthens the sensing distance.

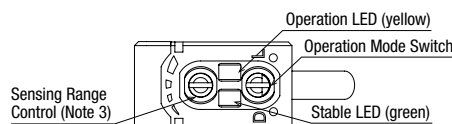

APEM

Switches & Pilot Lights

Control Boxes

Emergency Stop Switches

Enabling Switches

Safety Products

Explosion Proof

Terminal Blocks

Relays & Sockets

Circuit Protectors

Power Supplies

LED Illumination

Controllers

Operator Interfaces

Sensors

AUTO-ID

SA1E

SA1E-L

Instructions

Power Supply and Wiring

- Do not use the SA1E-L photoelectric switch in the transient status immediately after turning on the power (approx. 100 ms). When the load and switch use different power supplies, make sure to power up the switch first.
- Use a power supply with little noise and inrush current, and use the photoelectric switch within the rated voltage range. Make sure that the ripple is within the allowable limit. Do not apply AC voltage, otherwise the switch may blow out or burn.
- When using a switching power supply, make sure to ground the FG (frame ground) terminal, otherwise high-frequency noise may affect the photoelectric switch.
- Turn power off before inserting/removing the connector on photoelectric switch. Make sure that excessive mechanical force is not applied to the connector. Connect the connector cable to a tightening torque of 0.5 N·m maximum.
- To ensure the degree of protection, use the applicable connector cable for the connector type. Connector cables are ordered separately (see M-027).
- Avoid parallel wiring with high-voltage or power lines in the same conduit, otherwise noise may cause malfunction and damage. When wiring is long, use a separate conduit for wiring.
- Use a cable of 0.3 mm² minimum core wires, then the cable can be extended up to 100 m.

Installation

Installing the Photoelectric Switch

- Do not install the SA1E-L photoelectric switches in an area where the switches are subject to the following conditions, otherwise malfunction and damage may be caused.
 - * Inductive devices or heat source
 - * Extreme vibration or shock
 - * Large amount of dust
 - * Toxic gases
 - * Water, oil, chemicals
 - * Outdoors
- Make sure to prevent sunlight, fluorescent light, and especially the fluorescent light of inverters from entering the receiver of the photoelectric switch directly. Keep the through-beam type receiver away from intense extraneous light.
- Interference prevention allows two SA1E-L switches to be mounted in close proximity. However, the through-beam model is not equipped with interference prevention. Maintain appropriate distance between the switches referring to the lateral displacement characteristics.
- Because the SA1E-L photoelectric switches are IP67 waterproof, the SA1E-L can be exposed to water. However, wipe water drops and smears from the lens and slit using a soft cloth to make sure of the best detecting performance.
- Acrylic resin is used for optical elements. Do not use ammonia or caustic soda for cleaning, otherwise optical elements will be dissolved. To remove dust and moisture build-up, use soft dry cloth.
- Tighten the mounting screws (M3) to a torque of 0.4 to 0.5 N·m. Do not tighten the mounting screws excessively or hit the switch with a hammer, otherwise the protection degree cannot be maintained.
- Installing the Reflector
 - Use M4 mounting screws for the IAC-R5 and IAC-R8 reflectors. Tighten the mounting screws to a tightening torque of 0.4 to 0.5 N·m maximum. Do not tighten the mounting screws excessively, otherwise the screw holes of the reflector will be damaged.
 - While optional reflector mounting bracket IAC-L2 is not supplied with mounting screws or nuts, the IAC-L3 and IAC-L5 are supplied with mounting screws for mounting the reflector on the bracket.

Installing the air blower mounting block SA9Z-A02

- When installing the SA9Z-A02 on the SA1E-L photoelectric switch, use the attached M3 mounting screws and tighten to a torque of 0.4 to 0.5 N·m maximum.
- Mounting bracket is not supplied with SA9Z-A02 and must be ordered separately. SA9Z-K01 mounting bracket can be used with SA9Z-A02. When installing the SA9Z-K01 mounting bracket on SA9Z-A02 air blower mounting block, use the M3 × 20 mounting screws supplied with SA9Z-A02. Do not use the mounting screws (M3 × 12) supplied with SA9Z-K01.
- The SA9Z-A02 cannot be used with the through-beam slits (SA9Z-S12, SA9Z-S13, and SA9Z-S14).
- The air tube fitting (M5) can be installed to either the top or side. The air tube is not supplied.
- Close the unused port using the supplied air supply port plugging screw (M5 × 6) and gasket to a tightening torque of 1 to 2 N·m maximum. The recommended air pressure is 0.1 to 0.3 MPa.

Installing the background suppression (BGS) type

- This sensor can detect objects correctly when the sensor head is installed perpendicular to the moving object. Install the sensor head as shown below to minimize sensing errors.

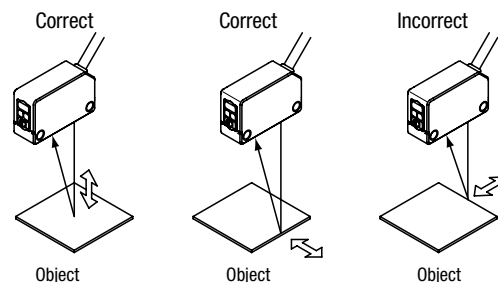

- If the SA1E-L is used in a place subject to large variations in the ambient temperature, the characteristics may change depending on the target object. Be sure to check the operation under the actual operating conditions.
- Polarized retroreflective: when the sensing objects have mirror surface, the reflected light from the mirror surface might cause false detection. Make sure that the reflected light does not enter the receiver.

Using a laser product

- The SA1E-L photoelectric switches radiate a visible laser beam. Do not look directly at laser beam. Also, do not look at the laser beam reflected by a mirror surface.
- IEC 60825-1 (Safety of laser products) sets safety standards of laser products. The SA1E-L photoelectric switches are classified as Class 1 product.
- The SA1E-L photoelectric switches comply with 21 CFR 1040.10 and 21 CFR 1040.11 according to Laser Notice No. 50, dated June 24, 2007, issued by the CDRH (Center for Devices and Radiological Health) under the FDA (Food and Drug Administration).
- Labels
 - According to IEC 60825-1 and FDA regulations, the SA1E-L has the warning and certification/identification labels as shown below. When installing the SA1E-L on a system/equipment used in the United States, ensure that the labels are attached to the SA1E-L.

