

RIGHT ANGLE PLUG CLAMP TYPE

R114.163.000

CABLE 2/50 S

Series : SMB

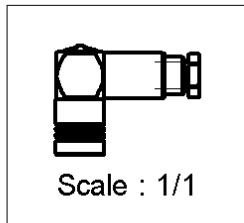
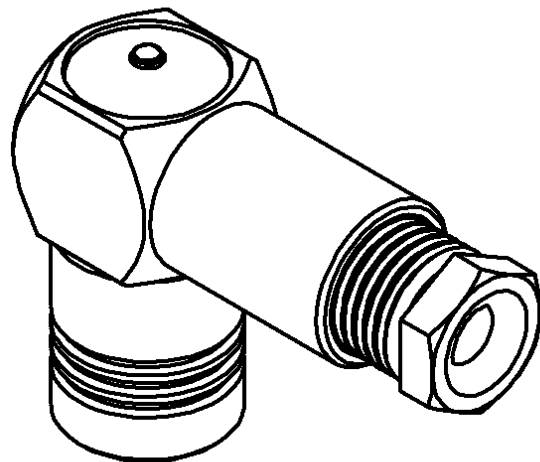
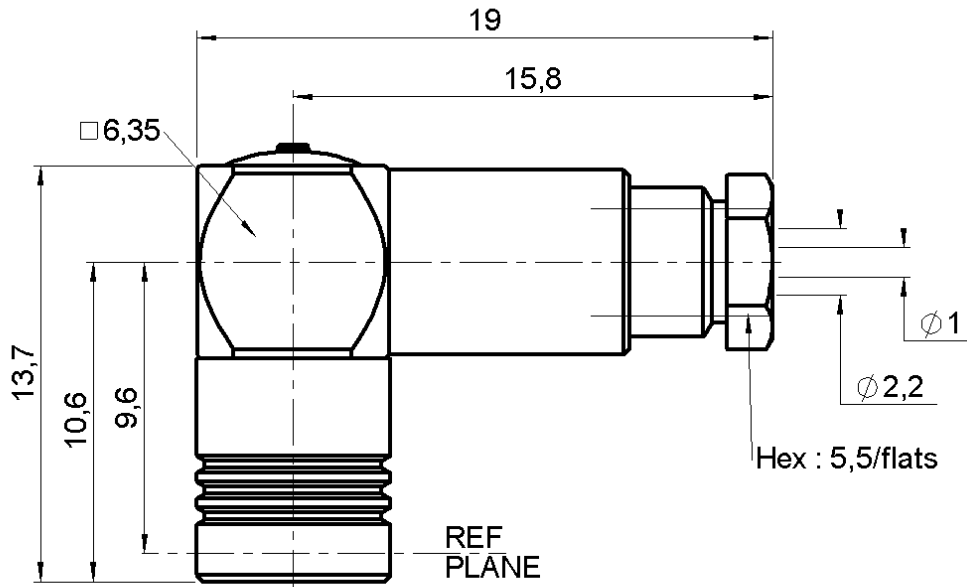

All dimensions are in mm.



COMPONENTS	MATERIALS	PLATINGS (µm)
BODY	BRASS	GOLD 0.2 OVER NICKEL 2
CENTER CONTACT	BERYLLIUM COPPER	GOLD 1.3 OVER NICKEL 2
OUTER CONTACT	BERYLLIUM COPPER	GOLD 0.5 OVER NICKEL 2
INSULATOR	PTFE	
GASKET	-	
OTHERS PARTS	BRASS	GOLD 0.2 OVER NICKEL 2
-	-	-
-	-	-

Issue : 0049 P

In the effort to improve our products, we reserve the right to make changes judged to be necessary.



RIGHT ANGLE PLUG CLAMP TYPE

R114.163.000

CABLE 2/50 S

Series : SMB

PACKAGING

Standard	Unit	Other
100	'W' option	Contact us

SPECIFICATION

CABLE ASSEMBLY

ELECTRICAL CHARACTERISTICS

Stripping	a	b	c	d	e	f
mm	1.50	0.00	4.00	5.00	2.00	0.00

Impedance		50	Ω
Frequency		0-4	GHz
VSWR	1.45 +	0.040	x F(GHz) Maxi
Insertion loss		0.50	\sqrt{F} (GHz) dB Maxi
RF leakage	- (57	- F(GHz)) dB mini
Voltage rating		250	Veff Maxi
Dielectric withstanding voltage		750	Veff mini
Insulation resistance		1000	M Ω mini

Assembly instruction :

Recommended cable(s)
 RG 178
 KX 21
 RG 196
 RG 178 LC

Cable retention

- pull off **58** N mini
 - torque **NA** N.cm

MECHANICAL CHARACTERISTICS

TOOLING

Center contact retention			
Axial force – Mating end		10	N mini
Axial force – Opposite end		10	N mini
Torque		NA	N.cm mini

Part Number	Description	Hexagon
.	.	.

Recommended torque			
Mating		NA	N.cm
Panel nut		NA	N.cm
Clamp nut		40	N.cm
A/F clamp nut		5.000	mm

OTHERS CHARACTERISTICS

Mating life		500	Cycles mini
Weight		4.800	g

ENVIRONMENTAL

Operating temperature		-65/+165	$^{\circ}$ C
Hermetic seal		NA	Atm.cm3/s
Panel leakage		NA	

Issue : 0049 P

In the effort to improve our products, we reserve the right to make changes judged to be necessary.



RIGHT ANGLE PLUG CLAMP TYPE

R114.163.000

CABLE 2/50 S

Series : SMB

COMPONENTS

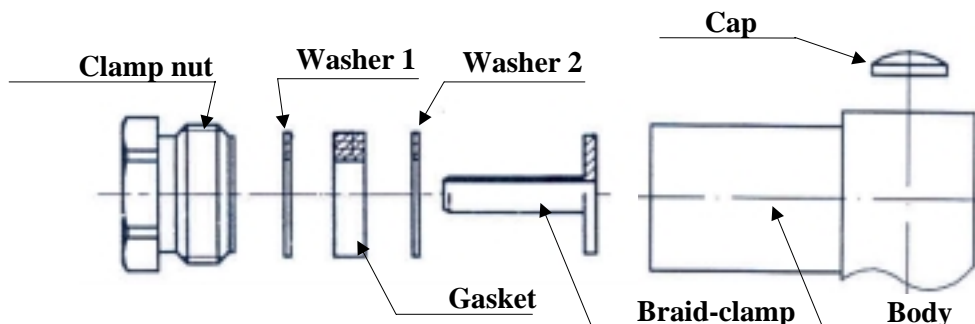

1

Slide the back nut, the washer 1, the gasket, the washer 2 onto the cable.
Strip the cable.
Cut 2 slits in the jacket if necessary.

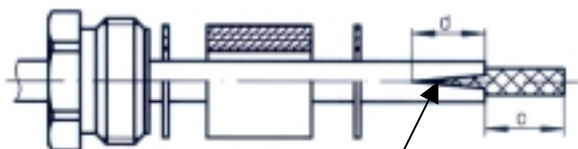

2 slits at 180°

3

Screw sub-assembly into the connector body with the adapted wrench.
Recommended coupling torque (see connector TDS).
Solder the inner conductor.

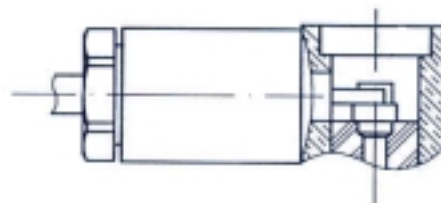

2

Mount the braid-clamp
Trim braid to Ø of braid-clamp
Strip off the dielectric

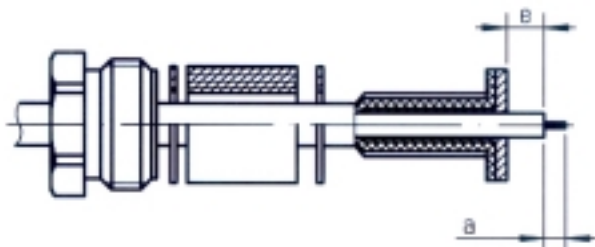

4

Place the cap into the body.
Press on the cap flush or slightly below the surface of the body assembly.

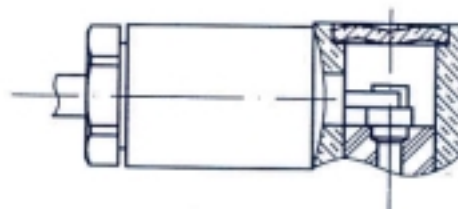

Issue : 0049 P

In the effort to improve our products, we reserve the right to make changes judged to be necessary.

