

THIS DRAWING IS UNPUBLISHED.      RELEASED FOR PUBLICATION      -.- .  
 © COPYRIGHT - TE Connectivity      ALL RIGHTS RESERVED.

| REVISIONS |     |                         |           |            |
|-----------|-----|-------------------------|-----------|------------|
| P         | LTR | DESCRIPTION             | DATE      | DRN / APVD |
| A         |     | GO TO PRODUCTION STATUS | 14JAN2019 | PH / AC    |

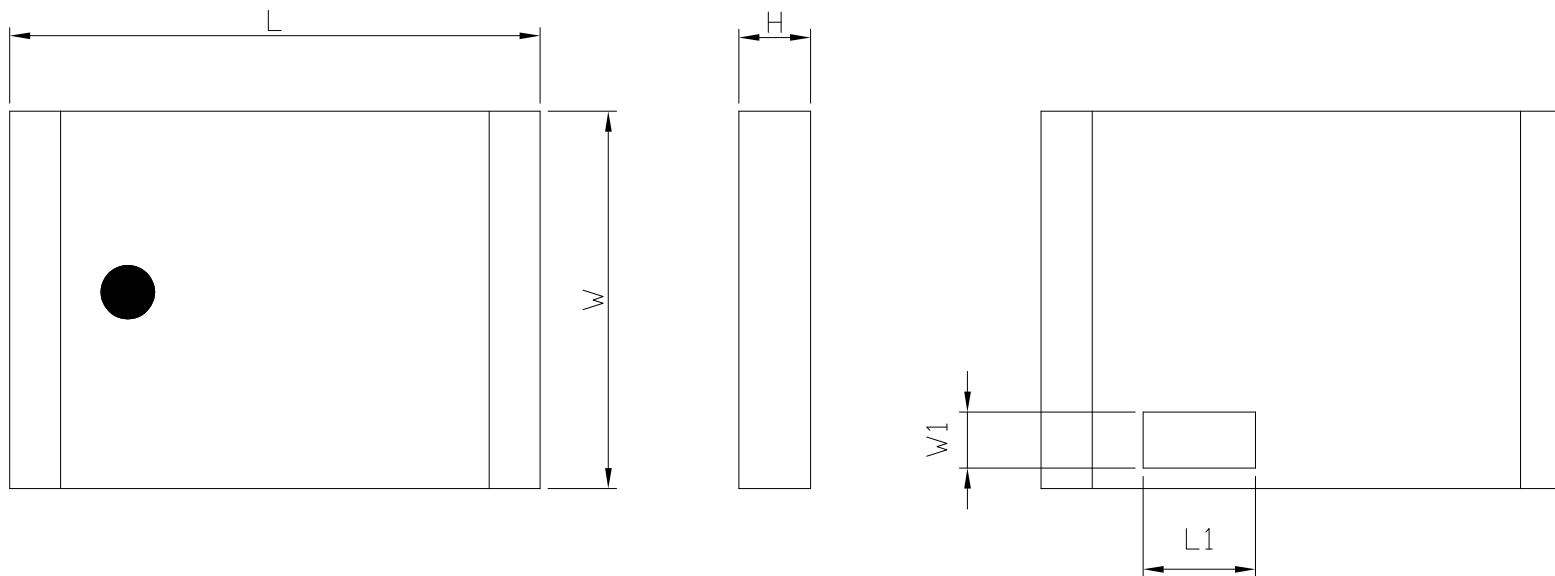

**L 5.20 ± 0.30**  
**W 3.70 ± 0.30**  
**H 0.70 ± 0.15**  
**L1 1.10 ± 0.20**  
**W1 0.55 ± 0.20**

**NOTES:**

1. MATERIALS : REFER TO TABLE.
2. A: ALL MATERIALS, COMPONENTS AND PROCESSES SHALL COMPLY WITH TEC-138-702 (CONTAINS NO BANNED OR RESTRICTED SUBSTANCES)  
 B: NO REACH SVHC SHALL BE CONTAINED ABOVE THE THRESHOLD AS DEFINED IN REACH SVHC  
 C: LOW HALOGEN: CODE 2(Br<900PPM, Cl<900PPM, Br+Cl<1500PPM PER HOMOGENEOUS MATERIAL) COMPLIANCE DEFINITION IN ANNEX A OF TEC-138-702
3. CONTACT TE CONNECTIVITY ENGINEERING PRIOR TO DESIGNING INTO AN APPLICATION

TE PN      2195764-1

|  |  |                           |                 |              |
|--|--|---------------------------|-----------------|--------------|
| THIS DRAWING IS A CONTROLLED DOCUMENT. |  | DRN PAUL HUNAG 20DEC2018  | TE Connectivity |              |
| DIMENSIONS: mm                         |  | CHK AMOS CHEAH 20DEC2018  |                 |              |
| TOLERANCES UNLESS OTHERWISE SPECIFIED: |  | APVD AMOS CHEAH 20DEC2018 | NAME            |              |
| 0 PLC ± -                              |  | PRODUCT SPEC              |                 |              |
| 1 PLC ± -                              |  | APPLICATION SPEC          |                 |              |
| 2 PLC ± -                              |  | SIZE CAGE CODE DRAWING NO |                 |              |
| 3 PLC ± -                              |  | A2 00779 C-2195764        |                 |              |
| 4 PLC ± -                              |  | RESTRICTED TO             |                 |              |
| ANGLES ± -                             |  | -                         |                 |              |
| MATERIAL -                             |  | WEIGHT -                  |                 |              |
| FINISH -                               |  | CUSTOMER DRAWING          |                 |              |
|  |  | SCALE 1:1                 |                 | SHEET 1 of 1 |
|  |  |                           |                 | REV A        |

# Mouser Electronics

Authorized Distributor

Click to View Pricing, Inventory, Delivery & Lifecycle Information:

[TE Connectivity:](#)

[2195764-1](#)