

5213 merchant

thermostatic mixing valves



WRAS
APPROVED
PRODUCT

altecnic

5213 merchant thermostatic mixing valve



Application

Thermostatic mixing valves are used to maintain the domestic hot water supplied to the user at a constant and safe temperature, when variations in the hot and cold water supply conditions and draw off flow rates occur.

The failsafe design shuts off the mixed water flow automatically in the event of disruption in the hot or cold water supply to the valve.

TMV3 and TMV2

The merchant range of fail safe thermostatic mixing valves have been designed and manufactured to meet the requirements of BS 7942:2000 and the National Health Service model engineering specification D08 for use in healthcare premises, hospitals, care homes, and schools.

The elderly, young children and the disabled are at particular risk of life threatening scalds due to a potential lack of mobility, skin sensitivity or the ability to communicate with their carer.

The valve has been independently tested and approved as a type 3 valve under the TMV3 scheme.

The valve also meet the requirements of BS EN 1111: 1999 and BS EN 1287: 1999 and the TMV2 Type Scheme. The valves have been independently tested and approved as a type 2 valve under the Buildcert TMV2 scheme by the WRc - NSF Limited / Buildcert Limited.

Merchant TMV2 thermostatic mixing valves are suitable for use in domestic housing and commercial building for single user outlets including wash basins, showers, baths and bidets but are also suitable for multiple outlet use.

Construction Details

Component	Material	Grade
Body	DZR - chrome plated	BS EN 12165 CW602N
Springs	Stainless steel	
Seals	EPDM	

Product Code	Size	Connection	Type
5213 Range			
CA-100822	15 mm	compression	Cu x Cu x Cu
CA-100824	22 mm	compression	Cu x Cu x Cu
CA-100827	15 mm	compression with MX valves	Cu x Cu x Cu
CA-100828	22 mm	compression with MX valves	Cu x Cu x Cu



Dimensions

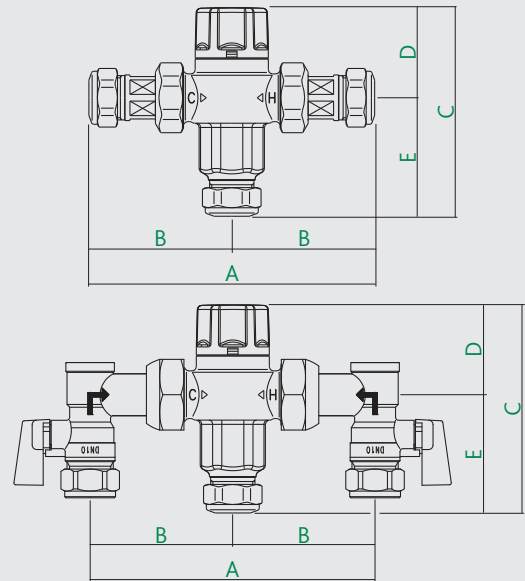

Prod Code	A	B	C	D	E	kg
CA-100822	141	67.5	99	43	56	0.5
CA-100824	150	75	100	43	57	0.6
CA-100827	120	60	99	43	56	0.65
CA-100828	136	68	100	43	57	0.75

Technical Data

Max. working pressure:	10 bar - Static
Min. working temperature:	0.2 Bar : Dynamic
Max. inlet temperature:	85°C
Inlet temperature range - hot supply:	52 - 65°C
- cold supply:	0.5 - 20°C
D08 working pressure - low pressure:	0.2 - 1.0
- high pressure:	1.0 - 5.0
Max. inlet pressure ratio (H/C or C/H):	5:1
Accuracy:	±2°C
Setting Range:	30 to 50°C
Min. temperature difference between inlet hot water and outlet mixed water:	10°C
Min. flow for stable operation	4 l/m

Kv Value & Flowrate

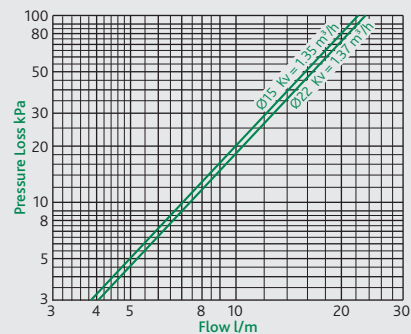

E & O.E

Altecnic Ltd Mustang Drive, Stafford, Staffordshire ST16 1GW

T: +44 (0)1785 218200 E: sales@altecnic.co.uk

Registered in England No: 2095101

altecnic.co.uk

AL 026 12-04-11