

Rev	AWO #	Description	Date	Appr
-		RELEASED	5/22/15	

APPROVED: _____
 DATE: _____ TITLE: _____

DE09-HD-PX-TS

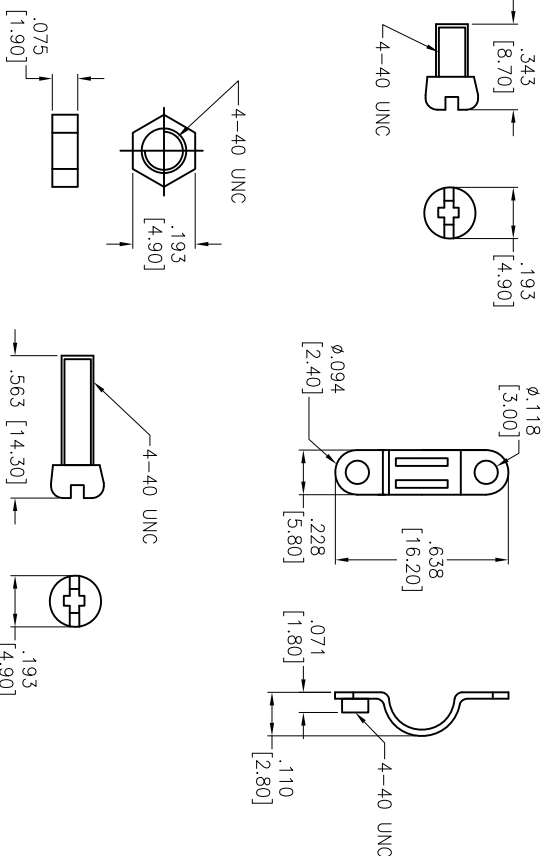
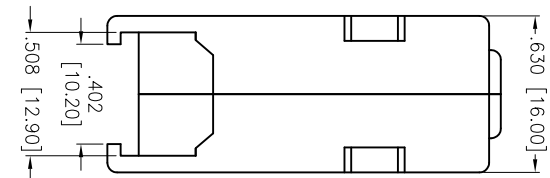
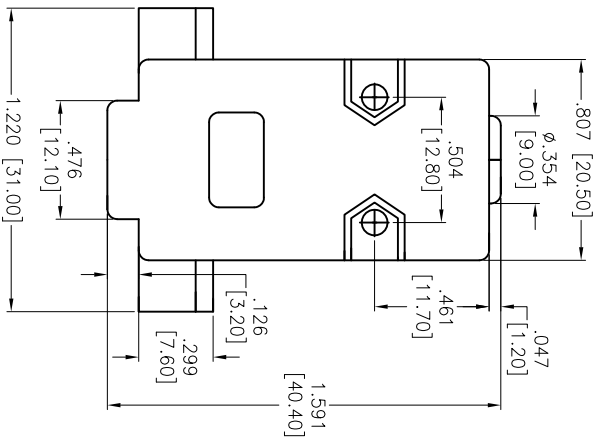
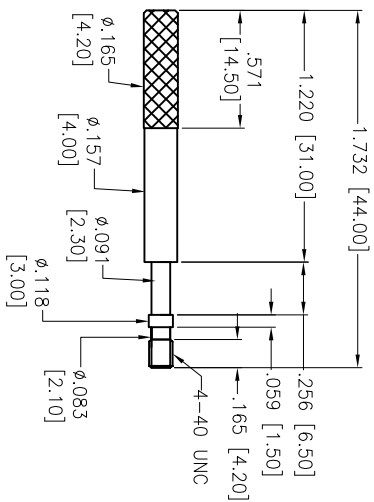
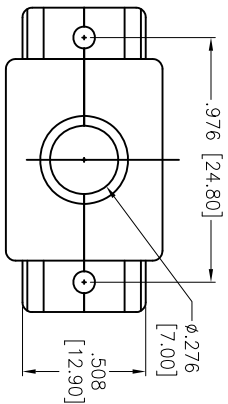

ADAM P/N	HOOD COLOR
DXXX-HD-PB-TS	BLACK PLASTIC
DXXX-HD-PN-TS	CHROME PLASTIC
DXXX-HD-PY-TS	GRAY PLASTIC

UNLESS OTHERWISE SPECIFIED ALL DIMENSIONS ARE INCHES [MM]	
TOLERANCES EXCEPT AS NOTED	
INCHES	HOLDERS
.X ± .10	ØXX ± .10
.XX ± .020	ØXXX ± .015
.XXX ± .015	ØXXXX ± .010
APPROVALS	DATE
DRAWN	HR
CHECKED	LL
APPROVED	

ADAM TECH
 909 Railway Avenue, Union, NJ 07083
 Phone: 908-687-5000 Fax: 908-687-5710

SPECIFICATIONS:
 Material:
 Insulator: ABS, rated UL 94HB
 Insulator color: Black
 Hardware: Steel, Chromate plated
 Environmental:
 Lead free, RoHS compliant



TITLE		D-SUB HOOD, THUMB SCREWS	
SIZE	PART NO.	REV.	
X	DXXX-HD-PX-TS	-	
REF:	S00064T	SCALE:	NTS
		SHEET	1 OF 5

6

5

4

3

2

1

Rev	AWO #	Description	Date	Appr
		SEE SHT 1 OF 2 FOR REVISION		

APPROVED: _____
 DATE: _____ TITLE: _____

DA15-HD-PX-TS

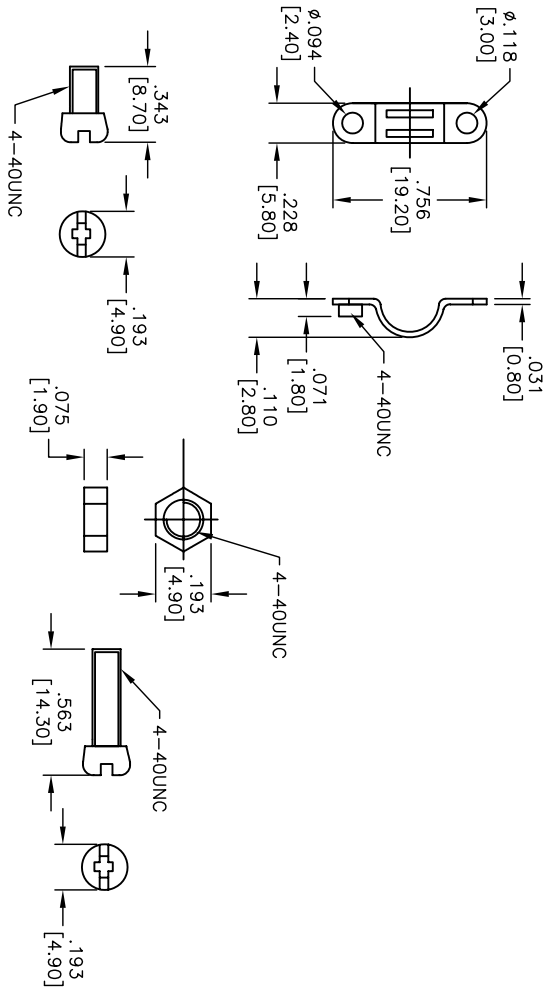
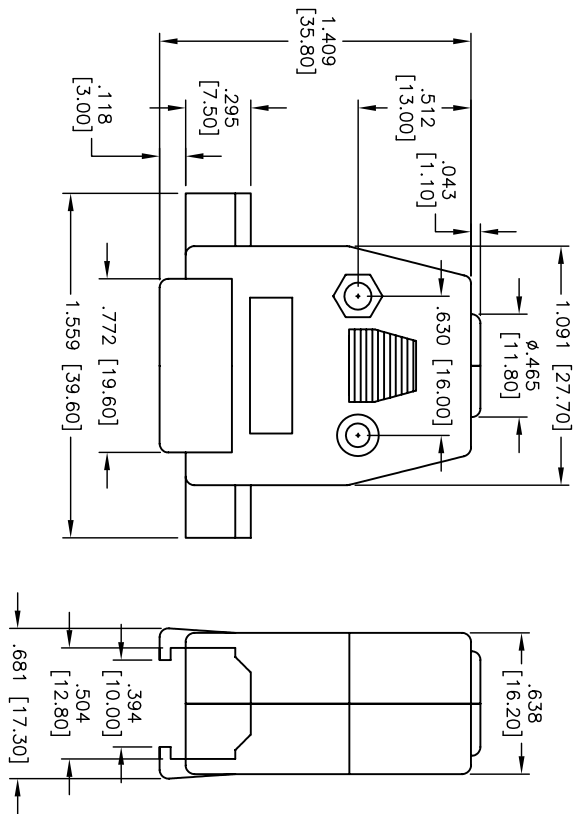
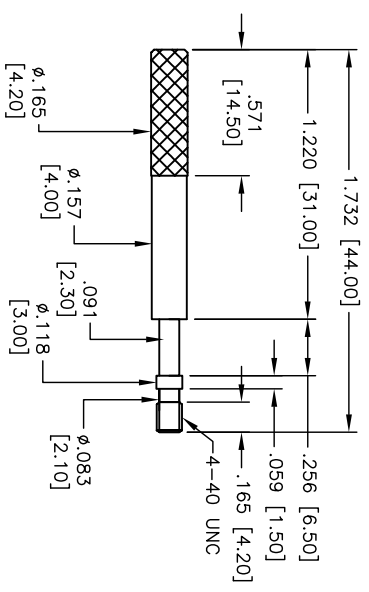
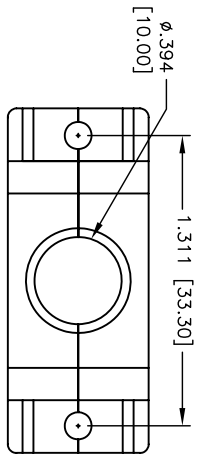

UNLESS OTHERWISE SPECIFIED
 ALL DIMENSIONS ARE IN INCHES [MM]
 TOLERANCES ARE AS NOTED
 INCHES
 .X ± .10 ØX ± .10
 .XX ± .020 ØXX ± .015
 .XXX ± .015 ØXXX ± .010

ADAM TECH
 909 Railway Avenue, Union, NJ 07083
 Phone: 908-687-5000 Fax: 908-687-5710

D-SUB HOOD, THUMB SCREWS

APPROVED	HR	DATE	SIZE	PART NO.	REV.
CHECKED	LL	5/22/15	X	DXXX-HD-PX-TS	-
DRAWN	HR	5/22/15			
APPROVALS					

6

5

4

3

2

1

6

5

4

3

2

1

Rev	AWO #	Description	Date	Appr
		SEE SH1 1 OF 5 FOR REVISION		

APPROVED: _____

DATE: _____ TITLE: _____

DB25-HD-PX-TS

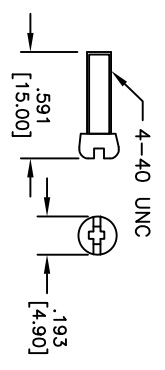
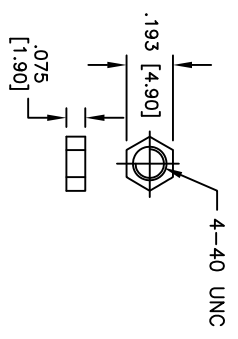
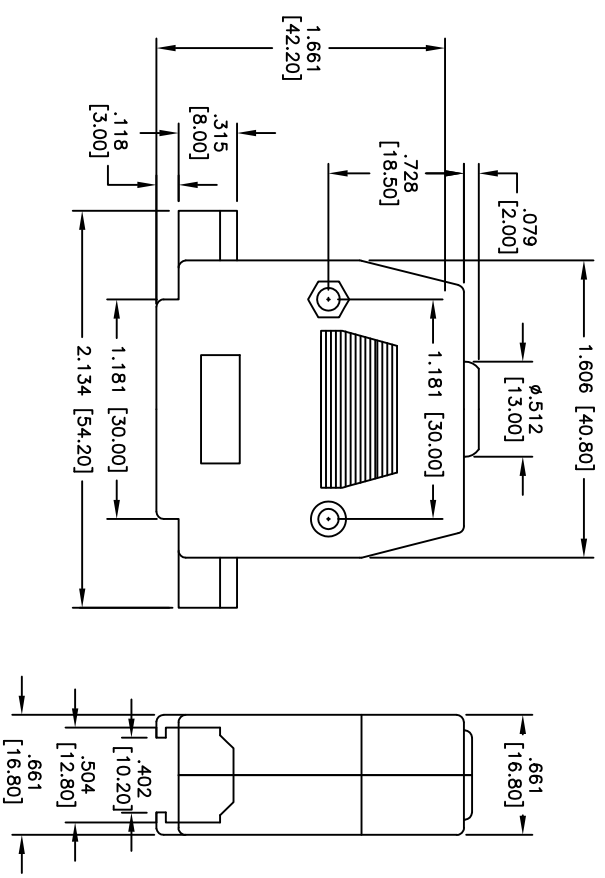
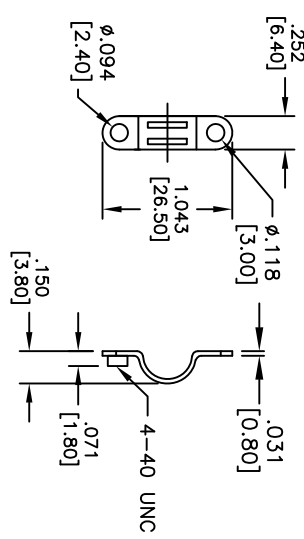
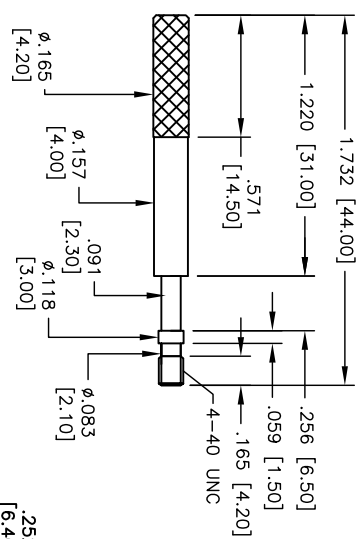
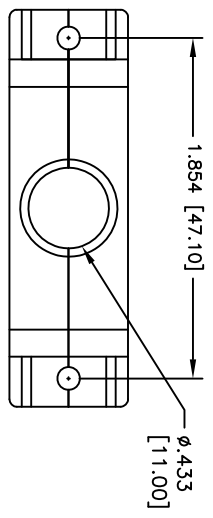

UNLESS OTHERWISE SPECIFIED
ALL DIMENSIONS ARE INCHES [MM]
TOLERANCES: EXCEPT AS NOTED
INCHES ±.10
.XX ±.020
.XXX ±.015

HOLE SIZE
ØXX ±.10
ØXXX ±.015
ØXXXX ±.010

APPROVALS

ADAM TECH
909 Railway Avenue, Union, NJ 07083
Phone: 908-687-5000 Fax: 908-687-5710

TITLE: D-SUB HOOD, THUMB SCREWS

DRAWN	HR	5/22/15
CHECKED	LL	5/22/15
APPROVED		

SIZE	PART NO.	REV.
X	DXXX-HD-PX-TS	-
REF:	S000&T	SHEET 3 OF 5

6

5

4

3

2

1

6

5

4

3

2

1

Rev	AWO #	Description	Date	Appr
		SEE SH1 1 OF 5 FOR REVISION		

APPROVED: _____

DATE: _____ TITLE: _____

DC37-HD-PX-TS

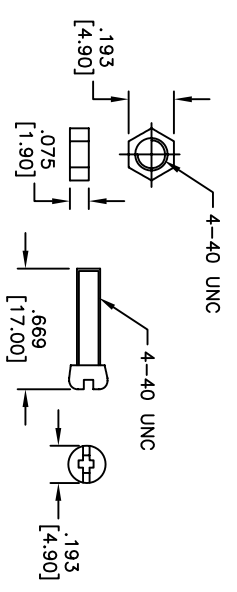
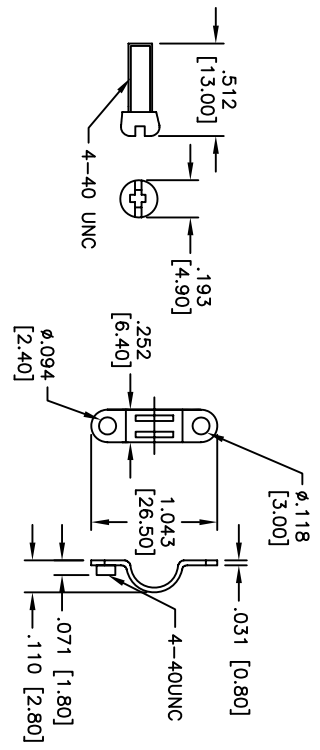
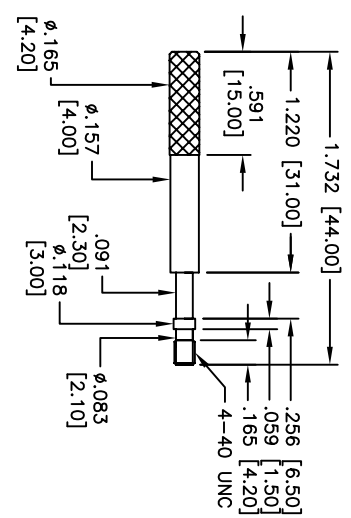
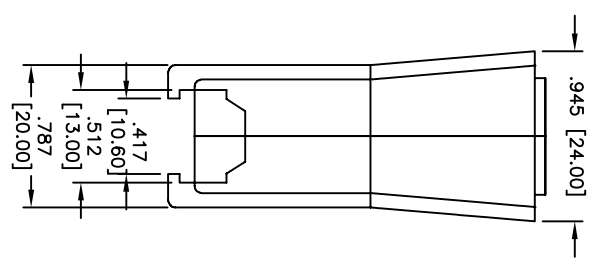
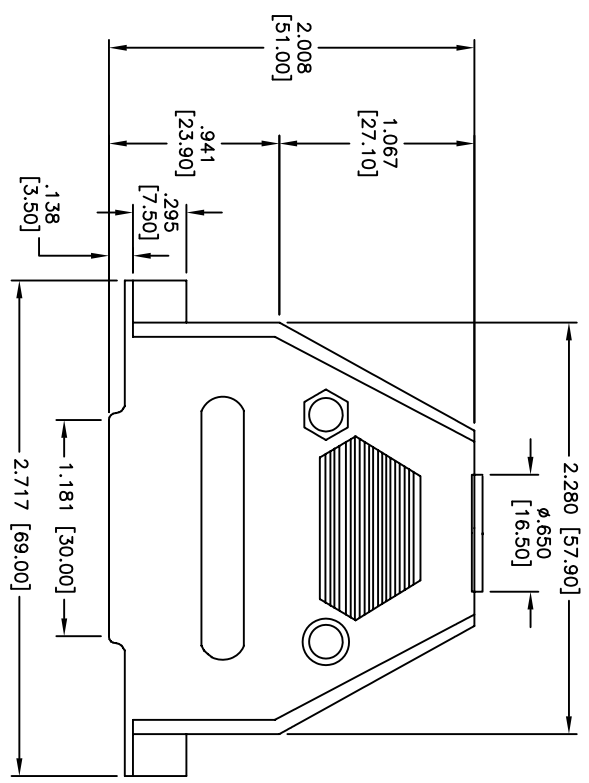
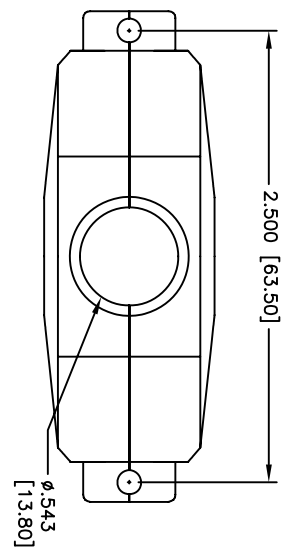

UNLESS OTHERWISE SPECIFIED
ALL DIMENSIONS ARE IN INCHES [MM]
TOLERANCES: EXCEPT AS NOTED
INCHES ± .10
Holes ± .015
X.XX ± .020
.XXX ± .015

ADAM TECH
909 Railway Avenue, Union, NJ 07083
Phone: 908-687-5000 Fax: 908-687-5710

D-SUB HOOD, THUMB SCREWS

DRAWN	AY	8/14/13	SIZE	PART NO.	REV.
CHECKED	AH	8/14/13	X	DXXX-HD-PX-TS	-
APPROVED			REF:	S00064T	SHEET 4 OF 5

6

5

4

3

2

1

Rev	AWO #	Description	Date	Appr
		SEE SHIT 1 OF 5 FOR REVISION		

APPROVED: _____
 DATE: _____ TITLE: _____

DD50-HD-PX-TS

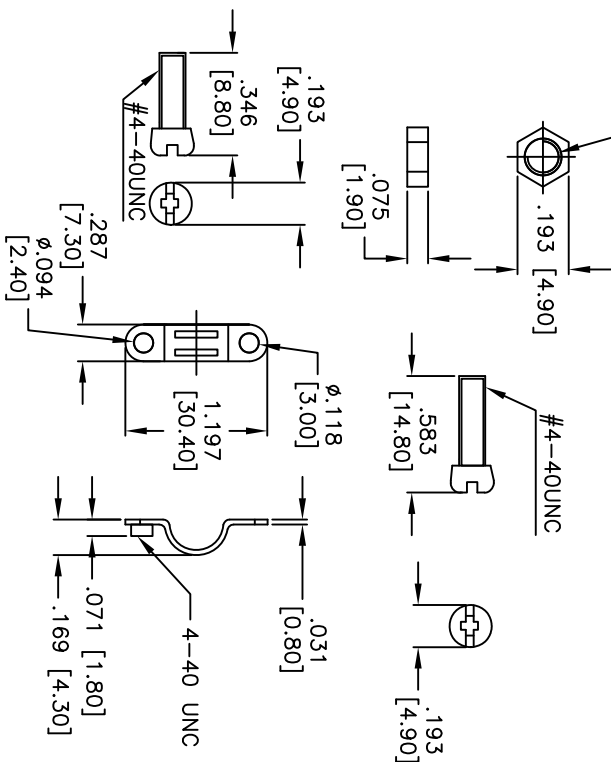
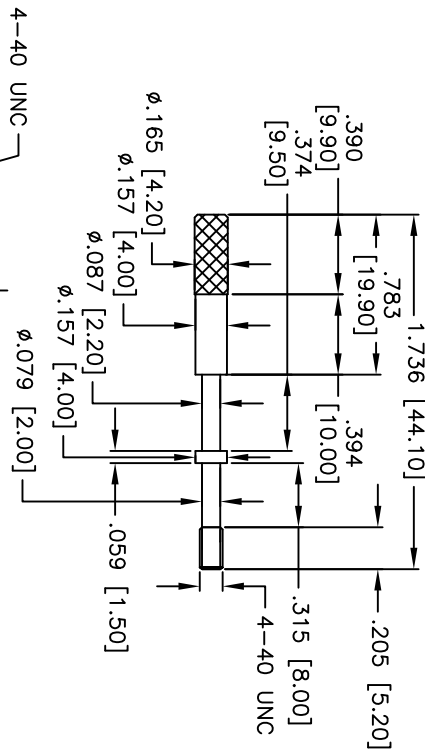
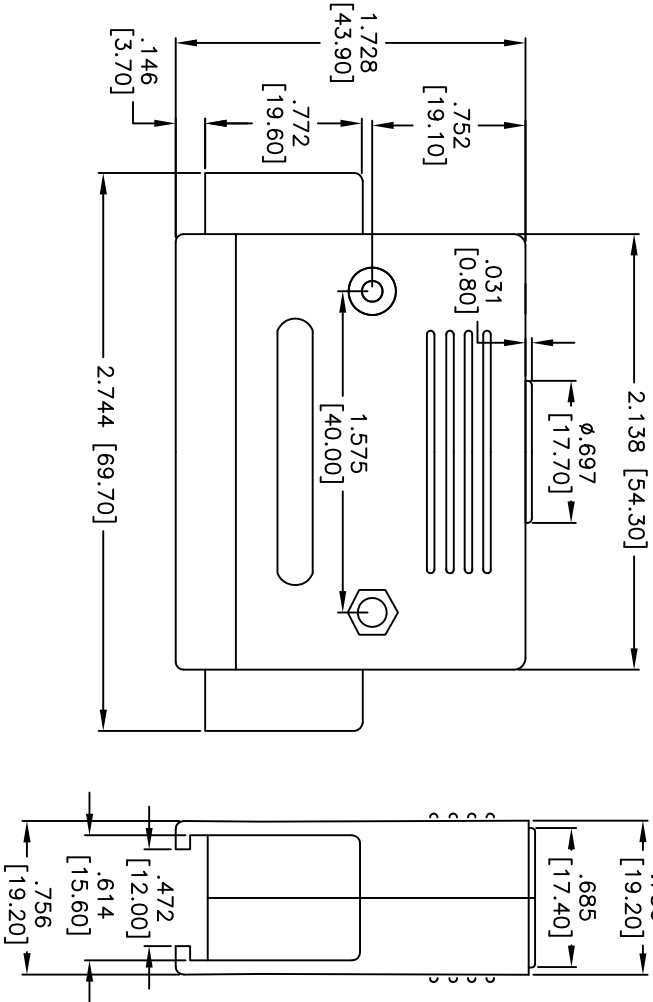
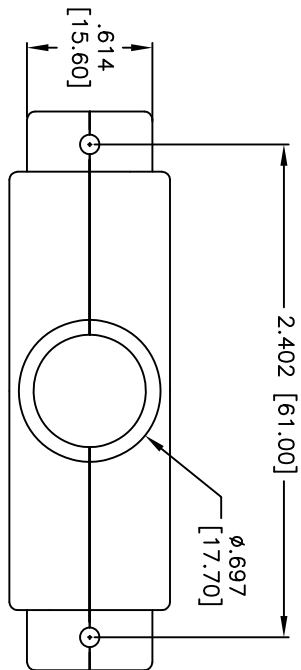

UNLESS OTHERWISE SPECIFIED
 ALL DIMENSIONS ARE IN INCHES [MM]
 TOLERANCES: EXCEPT AS NOTED
 INCHES: .X ± .10, .XX ± .020, .XXX ± .015
 HOLES: ØX ± .10, ØXXX ± .015
 APPROVALS: _____ DATE: _____

ADAM TECH
 909 Railway Avenue, Union, NJ 07083
 Phone: 908-687-5000 Fax: 908-687-5710

D-SUB HOOD, THUMB SCREWS

DRAWN	HR	5/22/15	SIZE	PART NO.	REV.
CHECKED	LL	5/22/15	X	DDXX-HD-PX-TS	-
APPROVED			REF: S0006AT	SCALE: NTS	SHEET 5 OF 5