

Stand-alone autonomous USB PD controller with short-to-VBUS protections

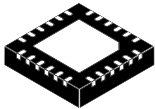

Product status link

[STUSB4700](#)

Features

- USB power delivery (PD) controller
- Type-C attach and cable orientation detection
- Single role: provider
- Full hardware solution - no software
- I²C interface + interrupt (optional connection to MCU)
- Supports up to 5 power data objects (PDO)
- Configurable start-up profiles
- Integrated V_{BUS} voltage monitoring
- Internal and/or external V_{BUS} discharge path
- Short-to-VBUS protections on CC pins (22 V)
- High voltage protections on V_{BUS} pins (28 V)
- High and/or low voltage power supply:
 - V_{SYS} = [3.0 V; 5.5 V]
 - V_{DD} = [4.1 V; 22 V]
- Automotive grade available
- Fully compatible with:
 - USB Type-C™ rev 1.2
 - USB PD rev 2.0
 - Certification test ID 1030023

Applications

- AC adapters and power supplies for: computer, consumer or portable consumer applications
- Smart plugs and wall adapters
- Power hubs and docking stations
- Displays
- Any Type-C source device

Description

The **STUSB4700** is a new family of USB power delivery controllers communicating over Type-C™ configuration channel pin (CC) to negotiate a given amount of power to be sourced to an inquiring consumer device.

The **STUSB4700** addresses provider/DFP devices such as notebooks, tablets and AC adapters. The device can handle any connections to a sink or DRP without any MCU control, from the device attachment to power negotiation, including V_{BUS} discharge and protections.

1 Functional description

The STUSB4700 is an autonomous USB power delivery controller optimized as a provider. It offers an open drain GPIO interface to make direct interconnection with a power regulation stage.

The STUSB4700 offers the benefits of a full hardware USB PD stack allowing robust and safe USB PD negotiation in line with USB PD standard. The STUSB4700 is ideal for provider applications in which digital or software intelligence is limited or missing.

The STUSB4700 main functions are:

- Detect the connection between two USB ports (attach detection)
- Establish a valid host to device connection
- Discover and configure V_{BUS} : Type-C low, medium or high current mode
- Resolve cable orientation
- Negotiate a USB power delivery contract with a PD capable device
- Configure the power source accordingly
- Monitor V_{BUS} , manage transitions, handle protections and ensure user and device safety

Additionally, the STUSB4700 offers 5 customizable power data objects (PDOs), 5 general purpose I/Os, an integrated discharge path, and is natively robust to high voltage peaks.

Figure 1. Functional block diagram

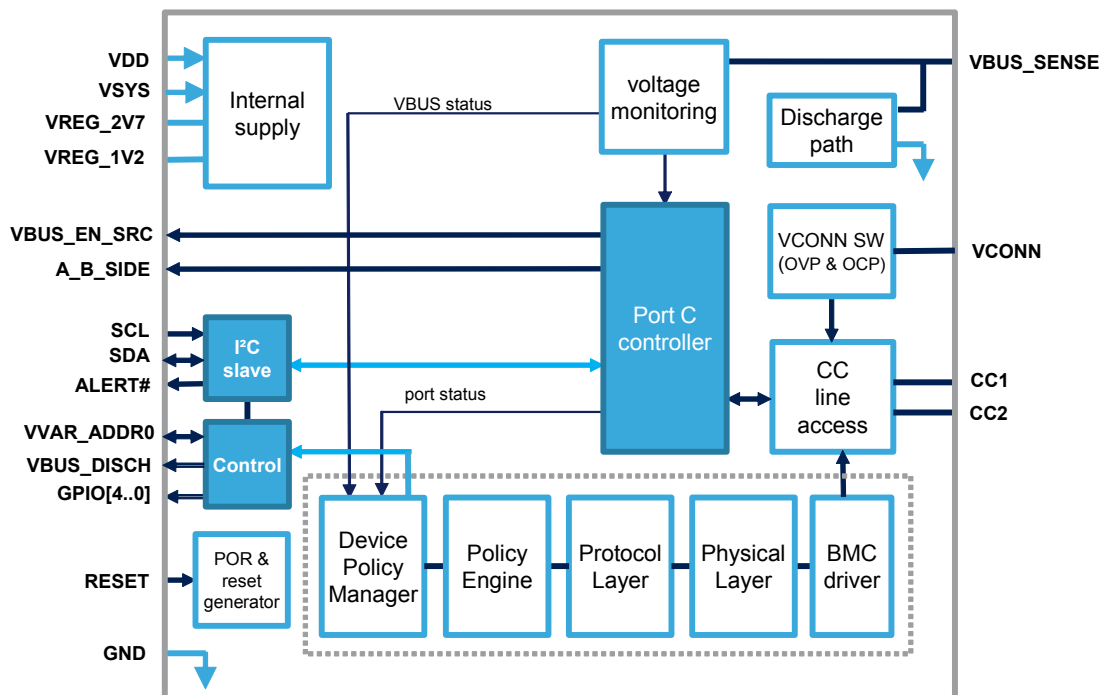

2 Inputs/outputs

2.1 Pinout

Figure 2. Pin connections (top view)

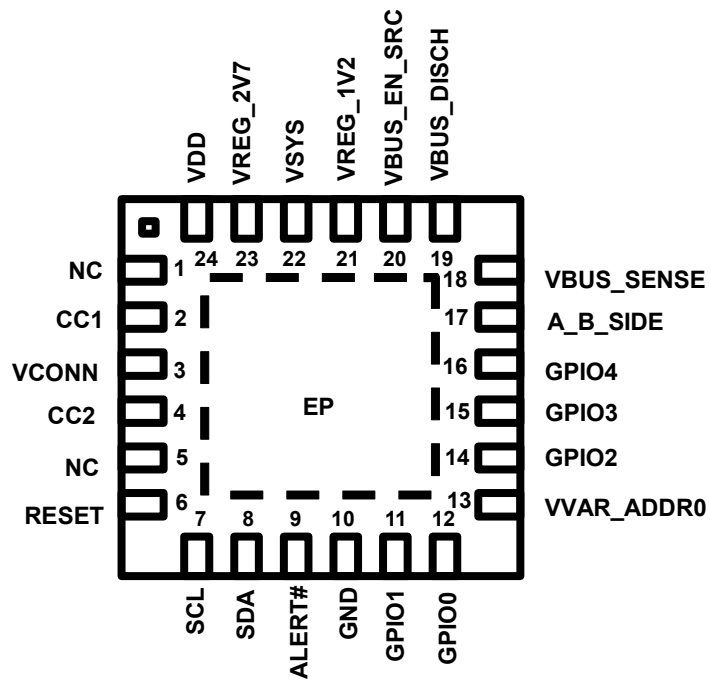

2.2 Pin list

Table 1. Pin function list

Pin	Name	Type	Description	Connection
1	NC		Ground reference channel 1	To ground
2	CC1	HV AIO	Type-C configuration channel 1	Type-C receptacle A5
3	VCONN	PWR	Power input for active plug	5 V power source
4	CC2	HV AIO	Type-C configuration channel 2	Type-C receptacle B5
5	NC	-	Ground reference channel 2	To ground
6	RESET	DI	Reset input (active high)	
7	SCL	DI	I ² C clock input	To I ² C master – ext. pull-up
8	SDA	DI/OD	I ² C data input/output – active low open drain	To I ² C master – ext. pull-up
9	ALERT#	OD	I ² C interrupt – active low open drain	To I ² C master – ext. pull-up
10	GND	GND	Ground	To ground
11	GPIO1	OD	General purpose I/O #1	
12	GPIO0	OD	General purpose I/O #0	
13	VVAR_ADDR0	AIO	Variable voltage output I ² C device address 0 bit (at start-up)	
14	GPIO2	OD	General purpose I/O #2	
15	GPIO3	OD	General purpose I/O #3	
16	GPIO4	OD	General purpose I/O #4	
17	A_B_SIDE	OD	Cable orientation - active low open drain	USB SuperSpeed mux select – ext. pull-up
18	VBUS_SENSE	HV AI	V _{BUS} voltage monitoring and discharge path	From V _{BUS}
19	VBUS_DISCH	HV OD	External output discharge path enable, active low open drain	
20	VBUS_EN_SRC	HV OD	V _{BUS} source power path enable – active low open drain	To switch or power system – ext. pull-up
21	VREG_1V2	PWR	1.2 V internal regulator output	1 μF typ. decoupling capacitor
22	VSYS	PWR	Power supply from system	System low power (connect to ground if not used)
23	VREG_2V7	PWR	2.7 V internal regulator output	1 μF typ. decoupling capacitor
24	VDD	HV PWR	Power supply from USB power line	From V _{BUS} (system side)
-	EP	Exposed pad	Exposed pad is connected to ground	To ground

Table 2. Legend

Type	Description
D	Digital
A	Analog
O	Output pad
I	Input pad
IO	Bidirectional pad
OD	Open drain output
PD	Pull-down
PU	Pull-up
HV	High voltage
PWR	Power
GND	Ground

2.3 Pin description

2.3.1 CC1 / CC2

CC1 and CC2 are the configuration channel pins used for connection and attachment detection, plug orientation determination and system configuration management across USB Type-C cable. CC1 and CC2 are high impedance (HiZ) during reset.

2.3.2 RESET

Active high reset. This pin resets all analog signals, states machine and reloads configuration.

2.3.3 I²C interface pins

Table 3. I²C interface pin list

Name	Description
SCL	I ² C clock – need external pull-up
SDA	I ² C data – need external pull-up
ALERT#	I ² C interrupt – need external pull-up

2.3.4 A_B_SIDE

This output pin provides cable orientation. It is used to establish USB SuperSpeed signals routing. The cable orientation is also provided by an internal I²C register. This signal is not required in case of USB 2.0 support or in case of supply only.

Table 4. USB data mux select

Value	CC pin position
HiZ	CC1 pin is attached to CC line
0	CC2 pin is attached to CC line

2.3.5 VBUS_SENSE

This input pin is used to sense V_{BUS} presence, monitor V_{BUS} voltage and discharge V_{BUS} on USB Type-C receptacle side.

2.3.6 VBUS_EN_SRC

In source power role, this pin allows enabling of the outgoing V_{BUS} power when the connection to a sink is established and V_{BUS} is in the valid operating range. The open-drain output allows a PMOS transistor to be driven directly. The logic value of the pin is also advertised in a dedicated I²C register bit.

2.3.7 V_{SYS}

This is the low voltage power supply from the system (if any). V_{SYS} connection is optional, and can be connected directly to a single cell Lithium battery or a system power supply delivering 3.3 V or 5 V. If not used, it is recommended to connect the pin to ground.

2.3.8 VDD

This is the main power supply from the USB power line for applications powered by V_{BUS} .

This pin can be used to sense the voltage level of the main power supply providing V_{BUS} . It allows UVLO and OVLO voltage thresholds to be considered independently on VDD pin as additional conditions to enable the V_{BUS} power path through $VBUS_EN_SRC$ pin.

2.3.9 GND

Ground.

2.3.10 VVAR_ADDR0

At start-up, this pin is latched to set I²C device address 0 bit. During operation, this output can be used as an analog voltage output to control the power management unit. Analog value is one tenth of the requested V_{BUS} value. This function can be enabled through appropriate non-volatile-memory (NVM) configuration.

2.3.11 VREG_2V7

This pin is used only for external decoupling of 2.7 V internal regulator.

Recommended decoupling capacitor: 1 μ F typ. (0.5 μ F min.; 10 μ F max.).

This pin must not be used to supply any external component.

2.3.12 VREG_1V2

This pin is used for external decoupling of 1.2 V internal regulator.

Recommended decoupling capacitor: 1 μ F typ. (0.5 μ F min.; 10 μ F max.).

This pin must not be used to supply any external component.

2.3.13 VBUS_DISCH

This output pin allows an external V_{BUS} discharge path to be controlled in addition to the internal discharge path when required by the application. The output pin is active at the same time as the activation of the internal discharge path.

2.3.14 VCONN

This power input is connected to a power source that can be a 5 V power supply, or a lithium battery. It is used to supply e-marked cables. It is internally connected to power switches that are protected against short-circuit and overvoltage. When a valid source-to-sink connection is determined and V_{CONN} power switches enabled, V_{CONN} is provided by the source to the unused CC pin.

2.3.15 GPIO [4:0]
Table 5. GPIO0 (pin #12) configuration

Select	NVM value	Configuration	Comments
GPIO0_sel	00b	Attach	Attached to sink (active low)
	01b	Reserved	Do not use
	10b	Reserved	
	11b	Sel_PDO2	PDO2 contract (active low)

Table 6. GPIO1 (pin #11) configuration

Select	NVM value	Configuration	Comments
GPIO1_sel	00b	VBUS_VALID	V _{BUS} at expected voltage (active low)
	01b	Reserved	Do not use
	10b	Reserved	
	11b	Sel_PDO3	PDO3 contract (active low)

Table 7. GPIO2 (pin #14) – GPIO3 (pin #15) – GPIO4 (pin #16) configuration

Select	NVM value	Configuration	Comments
GPIO234_sel[1:0]	00b	GPIO2 = Sel_PDO2	PDO2 contract (active low)
		GPIO3 = Sel_PDO3	PDO3 contract (active low)
		GPIO4 = VBUS_EN_SRC_N	Not VBUS_EN_SRC (active high)
	01b	GPIO2 = ADDR1	I ² C device address 1 bit (at start-up)
		GPIO3 = ADDR2	I ² C device address 2 bit (at start-up)
		GPIO4 = DEBUG1	SNK_DEBUG_ACCESSORY from Type-C
	10b	Reserved	Do not use
	11b	GPIO2 = Sel_PDO4	PDO4 contract (active low)
		GPIO3 = Sel_PDO5	PDO5 contract (active low)
GPIO4 = V_TRANS_UP		PDO transition up (active low for 280 ms)	

Other configurations are available (please contact our customer support).

3 Block descriptions

3.1 CC interface

The STUSB4700 controls the connection to the configuration channel (CC) pins, CC1 and CC2, through two main blocks, the CC lines interface block and the CC control logic block.

The CC lines interface block is used to:

- Configure the pull-up termination mode on the CC pins
- Monitor the CC pin voltage values relative to the attachment detection thresholds
- Configure V_{CONN} on the unconnected CC pin when required
- Protect the CC pins against over voltage

The CC control logic block is used to:

- Execute the Type-C FSM relative to the Type-C source power mode
- Determine the electrical state for each CC pins relative to the detected thresholds
- Evaluate the conditions relative to the CC pin states and V_{BUS} voltage value to transition from one state to another in the Type-C state machine
- Detect and establish a valid source-to-sink connection
- Determine the attached device type: sink or accessory
- Determine cable orientation to allow external routing of the USB SuperSpeed data
- Expose V_{BUS} power capability: USB default, Type-C medium or Type-C high current mode
- Handle hardware faults

The CC control logic block implements the Type-C state machines corresponding to source power role with accessory support.

3.2 BMC

This block is the physical link between USB PD protocol layer and CC pin. In TX mode, it converts the data into bi-phase mark coding (BMC), and drives the CC line to correct voltages. In RX mode, it recovers BMC data from the CC line, and converts to baseband signaling for the protocol layer.

3.3 Protocol layer

The protocol layer has the responsibility to manage the messages from/to the physical layer. It automatically manages the protocol receive timeouts, the message counter, the retry counter and the GoodCRC messages. It communicates with the internal policy engine.

3.4 Policy engine

The policy engine implements the power negotiation with the connected device according to its source role, it implements all states machine that controls protocol layer forming and scheduling the messages.

The policy engine uses the protocol layer to send/receive messages.

The policy engine interprets the device policy manager's input in order to implement policy for port and directs the protocol layer to send appropriate messages.

3.5 Device policy manager

The device policy manager is managing the power resources.

3.6 VBUS power path control

3.6.1 VBUS monitoring

The V_{BUS} monitoring block supervises from the V_{BUS_SENSE} input pin the V_{BUS} voltage on the USB Type-C receptacle side.

This block is used to check that V_{BUS} is within a valid voltage range:

- To establish a valid source-to-sink connection according to USB Type-C standard specification
- To enable safely the V_{BUS} power path through $VBUS_EN_SRC$ pin

It allows detection of unexpected V_{BUS} voltage conditions such as undervoltage or overvoltage relative to the valid V_{BUS} voltage range. When such conditions occur, the STUSB4700 reacts as follows:

- At attachment, it prevents the source-to-sink connection and the V_{BUS} power path assertion
- After attachment, it deactivates the source-to-sink connection and disables the V_{BUS} power path. The device goes into error recovery state

The V_{BUS} voltage value is automatically adjusted at attachment and at each PDO transition. The monitoring is then disabled during $T_Transition_To_PDO$ (default 288 ms changed through NVM programming). Additionally, if a transition occurs to a lower voltage, the discharge path is activated during this time.

The valid V_{BUS} voltage range is defined from the V_{BUS} nominal voltage by a high threshold voltage and a low threshold voltage whose minimal values are respectively $V_{BUS}+5\%$ and $V_{BUS}-5\%$. The nominal threshold limits can be shifted by a fraction of V_{BUS} from +1% to +15% for the high threshold voltage and from -1% to -15% for the low threshold voltage. It means the threshold limits can vary from $V_{BUS}+5\%$ to $V_{BUS}+20\%$ for the high limit and from $V_{BUS}-5\%$ to $V_{BUS}-20\%$ for the low limit.

The threshold limits are preset by default in the NVM with different shift coefficients (see [Section 8.3 Electrical and timing characteristics](#)). The threshold limits can be changed independently through NVM programming (see [Section 4 User-defined start-up configuration](#)) and also by software during attachment through the I²C interface (see [Section 6 I²C register map](#)).

3.6.2 VBUS discharge

The monitoring block handles also the internal V_{BUS} discharge path connected to the $VBUS_SENSE$ input pin. The discharge path is activated at detachment, during transition to a lower PDO voltage, or when the device goes into the error recovery state (see [Section 3.8 Hardware fault management](#)).

The automatic V_{BUS} discharge path feature is enabled by default in the NVM and can be disabled through NVM programming only (see [Section 4 User-defined start-up configuration](#)). Discharge time duration ($T_Transition_To_PDO$ and $T_Transition_To_0V$) are also preset by default in the NVM (see [Section 8.3 Electrical and timing characteristics](#)). The discharge time duration can be changed through NVM programming (see [Section 4 User-defined start-up configuration](#)) and also by software through the I²C interface (see [Section 6 I²C register map](#)).

3.6.3 VBUS power path assertion

The STUSB4700 can control the assertion of the V_{BUS} power path on USB Type-C port, directly or indirectly, through $VBUS_EN_SRC$ pin.

The following table summarizes the configurations of the STUSB4700 and the operation conditions that determine the electrical value of the $VBUS_EN_SRC$ pin during system operations.

Table 8. Conditions for VBUS power path assertion

Pin	Electrical value	Operating conditions			Comment
		Type-C attached state	V _{DD} monitoring	VBUS-SENSE pin monitoring	
VBUS_EN_SRC	0	Attached.SRC UnorientedDebug Accessory.SRC OrientedDebug Accessory.SRC	V _{DD} > V _{DDUVLO} if UVLO threshold detection enabled and/or V _{DD} < V _{DDOVLO} if OVLO threshold detection enabled	V _{BUS} < V _{MONUSBH} and V _{BUS} > V _{MONUSBL} if V _{BUS} voltage range detection enabled or V _{BUS} > V _{THUSB} if V _{BUS} voltage range detection disabled	The signal is asserted only if all the valid operation conditions are met
	HiZ	Any other state	V _{DD} < V _{DD} if UVLO threshold detection enabled or V _{DD} > V _{DDOVLO} if OVLO threshold detection enabled	V _{BUS} > V _{MONUSBH} or V _{BUS} < V _{MONUSBL} if V _{BUS} voltage range detection enabled or V _{BUS} < V _{THUSB} if V _{BUS} voltage range detection disabled	The signal is de-asserted when at least one non-valid operation condition is met

Note: Activation of the UVLO and OVLO threshold detections can be done through NVM programming (see Section 4 User-defined start-up configuration) and also by software through the I²C interface (see Section 6 I²C register map). When the UVLO and/or OVLO threshold detection is activated, the VBUS_EN_SRC pin is asserted only if the device is attached and the valid threshold conditions on VDD are met. Once the VBUS_EN_SRC pin is asserted, the V_{BUS} monitoring is done on VBUS_SENSE pin instead of the V_{DD} pin.

3.7 High voltage protection

The STUSB4700 can be safely used in systems or connected to systems that handle high voltage on the V_{BUS} power path. The device integrates an internal circuitry on the CC pins that tolerates high voltage and ensures a protection up to 22 V in case of unexpected short circuit with V_{BUS} or in case of connection to a device supplying high voltage on V_{BUS}.

3.8 Hardware fault management

The STUSB4700 handles hardware fault conditions related to the device itself and to the V_{BUS} power path during system operation.

When such conditions happen, the circuit goes into a transient error recovery state named ErrorRecovery in the Type-C FSM. The error recovery state is equivalent to force a detach event. When entering this state, the device de-asserts the VBUS power path by disabling the VBUS_EN_SRC pin, and it removes the terminations from the CC pins during several tens of milliseconds. Then, it transitions to the unattached source state.

The STUSB4700 goes into error recovery state when at least one condition listed below is met:

- If an overtemperature is detected, the “THERMAL_FAULT” bit is set to 1b
- If an internal pull-up voltage on CC pins is below UVLO threshold, the “VPU_VALID” bit is set to 0b
- If an overvoltage is detected on the CC pins, the “VPU_OVP_FAULT” bit is set to 1b
- If the V_{BUS} voltage is out of the valid voltage range during attachment, the “VBUS_VALID” bit is set to 0b
- If an undervoltage is detected on the V_{DD} pin during attachment when UVLO detection is enabled, the “VDD_UVLO_DISABLE” bit is set to 0b
- If an overvoltage is detected on the V_{DD} pin during attachment when OVLO detection is enabled, the “VDD_OVLO_DISABLE” bit is set to 0b

The I²C register bits mentioned above in quotes give either the state of the hardware fault when it occurs or the setting condition to detect the hardware fault.

3.9 Accessory mode detection

The STUSB4700 supports the detection of audio accessory mode and debug accessory mode as defined in the USB Type-C standard specification source power role with accessory support.

3.9.1 Audio accessory mode detection

The STUSB4700 detects an audio accessory device when both the CC1 and CC2 pins are pulled down to ground by a R_a resistor from the connected device. The audio accessory detection is advertised through the CC_ATTACHED_MODE bits of the I²C register CC_CONNECTION_STATUS.

3.9.2 Debug accessory mode detection

The STUSB4700 detects a connection to a debug and test system (DTS). The debug accessory detection is advertised through the CC_ATTACHED_MODE bits of the I²C register CC_CONNECTION_STATUS.

The VBUS_EN_SRC pin is also asserted to allow the VBUS power path to be enabled as defined in the USB Type-C standard specification.

A debug accessory device is detected when both the CC1 and CC2 pins are pulled down to ground by a R_d resistor from the connected device. The orientation detection is performed in two steps as described in the table below. The A_B_SIDE pin indicates the orientation of the connection. The orientation detection is advertised through the TYPEC_FSM_STATE bits of the I²C register CC_OPERATION_STATUS.

Table 9. The orientation detection

#	CC1 pin (CC2 pin)	CC2 pin (CC1 pin)	Detection process	A_B_SIDE pin CC1/CC2 (CC2/CC1)	Orientation detection state TYPEC_FSM_STATE bit value
1	Rd	Rd	1 st step: debug accessory mode detected	HiZ (HiZ)	UnorientedDebugAccessory.SRC
2	Rd	≤ Ra	2 nd step: orientation detected (DTS presents a resistance to GND with a value ≤ Ra on its CC2 pin)	HiZ (0)	OrientedDebugAccessory.SRC

4 User-defined start-up configuration

4.1 Parameter overview

The STUSB4700 has a set of user-defined parameters that can be customized by NVM re-programming and/or by software through I²C interface. It allows changing the preset configuration of USB Type-C and PD interface and to define a new configuration to meet specific customer requirements addressing various applications, use cases or specific implementations.

The NVM re-programming overrides the initial default setting to define a new default setting that will be used at power-up or after a reset. The default value is copied at power-up, or after a reset, from the embedded NVM into dedicated I²C register bits. The NVM re-programming is possible few times with a customer password.

Table 10. PDO configurations in NVM

Feature	Parameter	Value
PDO1	Voltage	5 V
	Current	Configurable – defined by PDO1_I [3:0]
PDO2	Voltage	Configurable – defined by PDO2_V [1:0]
	Current	Configurable – defined by PDO2_I [3:0]
PDO3	Voltage	Configurable – defined by PDO3_V [1:0]
	Current	Configurable – defined by PDO3_I [3:0]
PDO4	Voltage	Configurable – defined by PDO4_V [1:0]
	Current	Configurable – defined by PDO4_I [3:0]
PDO5	Voltage	Configurable – defined by PDO5_V [1:0]
	Current	Configurable – defined by PDO5_I [3:0]

When a default value is changed during system boot by software, the new settings apply as long as the STUSB4700 operates and until it is changed again. But after power-off and power-up, or after a hardware reset, the STUSB4700 takes back default values defined in the NVM.

4.2 PDO – voltage configuration in NVM

PDO2_V [1:0], PDO3_V [1:0], PDO4_V [1:0] and PDO5_V [1:0] can be configured with the following values:

Table 11. PDO NVM voltage configuration

Value	Configuration
2b00	9 V
2b01	15 V
2b10	PDO_FLEX_V1
2b11	PDO_FLEX_V2

PDO_FLEX_V1 and PDO_FLEX_V2 are defined in a specific 10-bit register, value is being expressed in 50 mV units.

For instance:

- PDO_FLEX_V1 = 10b0100100010 → 14.5 V
- PDO_FLEX_V2 = 10b0110000110 → 19.5 V

4.3 PDO – current configuration in NVM

PDO1_I [3:0], PDO2_I [3:0], PDO3_I [3:0], PDO4_I [3:0] and PDO5_I [3:0] can be configured with the following fixed values:

Table 12. PDO NVM current configuration

Value	Configuration
4b0000	PDO_FLEX_I
4b0001	1.50 A
4b0010	1.75 A
4b0011	2.00 A
4b0100	2.25 A
4b0101	2.50 A
4b0110	2.75 A
4b0111	3.00 A
4b1000	3.25 A
4b1001	3.50 A
4b1010	3.75 A
4b1011	4.00 A
4b1100	4.25 A
4b1101	4.50 A
4b1110	4.75 A
4b1111	5.00 A

PDO_FLEX_I is defined in a specific 10-bit register, value is being expressed in 10 mA units. For instance:

- PDO_FLEX_I = 10b0011100001 → 2.25 A

4.4 Monitoring configuration in NVM

- T_Transition_To_PDO (T_{DISUSBPDO}) can be configured from 20 to 300 ms by increments of 20 ms (0 is not recommended)

- T_Transition_To_0V ($T_{DISUSB0V}$) can be configured from 84 to 1260 ms by increments of 84 ms (0 is not recommended)
- V_Shift_High (V_{SHUSBH}) can be configured from 1% to 15% of V_{BUS} by step of 1%
- V_Shift_Low (V_{SHUSBL}) can be configured from 1% to 15% of V_{BUS} by step of 1%

4.5 Factory settings

Table 13. Factory NVM setting

Parameter	STUSB4700QTR	STUSB4700YQTR
Number of PDO	5	3
PDO1 (UVLO; OVLO)	5 V / 3 A (-10%; +12%)	5 V / 3 A (-10%; +12%)
PDO2	9 V / 3 A (-10%; +10%)	9 V / 3 A (-10%; +10%)
PDO3	12 V / 3 A (-10%; +10%)	12 V / 3 A (-10%; +10%)
PDO4	15 V / 3 A (-10%; +10%)	-
PDO5	20 V / 2.25 A (-10%; +8%)	-
GPIO0	Sel_PDO2	Sel_PDO2
GPIO1	Sel_PDO3	Sel_PDO3
GPIO2	Sel_PDO4	Sel_PDO2
GPIO3	Sel_PDO5	Sel_PDO3
GPIO4	V_TRANS_UP	VBUS_EN_SRC_N
Discharge time: transition to PDO	240 ms	240 ms
Discharge time: transition to 0 V	168 ms	168 ms

5 I²C interface

5.1 Read and write operations

The I²C interface is used to configure, control and read the status of the device. It is compatible with the Philips I²C Bus® (version 2.1). The I²C is a slave serial interface based on two signals:

- SCL - serial clock line: input clock used to shift data
- SDA - serial data line: input/output bidirectional data transfers

A filter rejects the potential spikes on the bus data line to preserve data integrity.

The bidirectional data line supports transfers up to 400 Kbit/s (fast mode). The data are shifted to and from the chip on the SDA line, MSB first.

The first bit must be high (START) followed by the 7-bit device address and the read/write control bit.

Eight 7-bit device addresses are available for the STUSB4700 thanks to the external programming of DevADDR0, DevADDR11 and/or DevADDR2 through VVAR_ADDR0, ADDR1 and ADDR2 pins respectively. It allows eight STUSB4700 devices to be connected on the same I²C bus.

Two addresses are available by default, i.e. 0x28 or 0x29, depending on the setting of the VVAR_ADDR0 pin (ADDR1 and ADDR2 set to 0 by default).

Table 14. Device address format

Bit7	Bit6	Bit5	Bit4	Bit3	Bit2	Bit1	Bit0
DevADDR6	DevADDR5	DevADDR4	DevADDR3	DevADDR2	DevADDR1	DevADDR0	R/W
0	1	0	1	ADDR2	ADDR1	ADDR0	0/1

Table 15. Register address format

Bit7	Bit6	Bit5	Bit4	Bit3	Bit2	Bit1	Bit0
RegADDR7	RegADDR6	RegADDR5	RegADDR4	RegADDR3	RegADDR2	RegADDR1	RegADDR0

Table 16. Register data format

Bit7	Bit6	Bit5	Bit4	Bit3	Bit2	Bit1	Bit0
DATA7	DATA6	DATA5	DATA4	DATA3	DATA2	DATA1	DATA0

Figure 3. Read operation

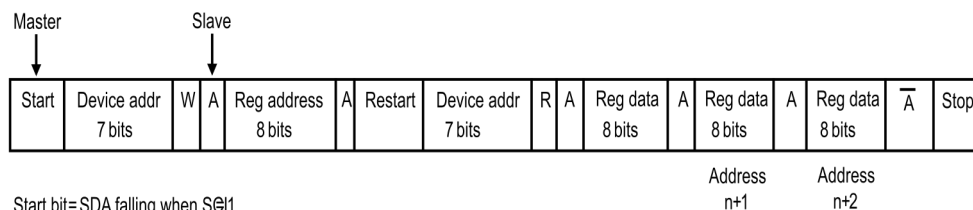

Start bit=SDA falling when S₀1
 Stop bit=SDA rising when S₀1
 Restart bit= start after a start
 Acknowledge=SDA forced low during a SCL clock

GAMG20170104EC-0003

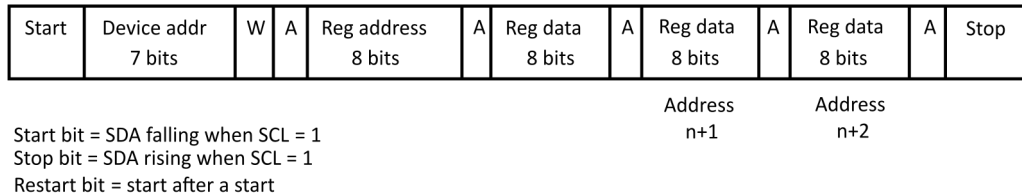
Figure 4. Write operation

GAMG20170104EC-0004

5.2 Timing specifications

The device uses a standard slave I²C channel at speed up to 400 kHz.

Table 17. I²C timing parameters - VDD = 5 V

Symbol	Parameter	Min.	Typ.	Max.	Unit
F_{scl}	SCL clock frequency	0	-	400	kHz
$t_{hd,sta}$	Hold time (repeated) START condition	0.6	-	-	μ s
t_{low}	LOW period of the SCL clock	1.3	-	-	μ s
t_{high}	HIGH period of the SCL clock	0.6	-	-	μ s
$t_{su,dat}$	Setup time for repeated START condition	0.6	-	-	μ s
$t_{hd,dat}$	Data hold time	0.04	-	0.9	μ s
$t_{su,dat}$	Data setup time	100	-	-	μ s
t_r	Rise time of both SDA and SCL signals	$20 + 0.1 C_b$	-	300	ns
t_f	Fall time of both SDA and SCL signals	$20 + 0.1 C_b$	-	300	ns
$t_{su,sto}$	Setup time for STOP condition	0.6	-	-	μ s
t_{buf}	Bus free time between a STOP and START condition	1.3	-	-	μ s
C_b	Capacitive load for each bus line	-	-	400	pF

Figure 5. I²C timing diagram

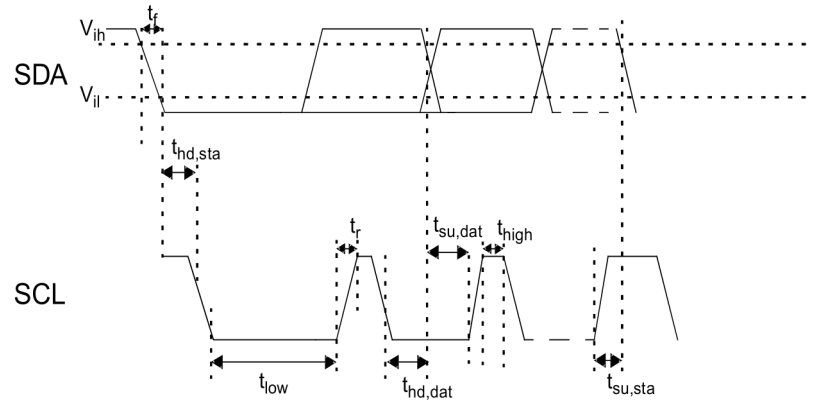

GAMG20170104EC-0005

6 I²C register map

Table 18. Register access legend

Access code	Expanded name	Description
RO	Read only	Register can be read only
R/W	Read/write	Register can be read or written
RC	Read and clear	Register can be read and is cleared after it is read

Table 19. STUSB4700 register map overview

Address	Register name	Access	Description
00h to 0Ah	Reserved	RO	Do not use
0Bh	ALERT_STATUS	RC	Alert register linked to transition registers
0Ch	ALERT_STATUS_MASK_CTRL	R/W	Allows the interrupt mask on the ALERT_STATUS register to be changed
0Dh	CC_CONNECTION_STATUS_TRANS	RC	Alerts about transition in CC_CONNECTION_STATUS register
0Eh	CC_CONNECTION_STATUS	RO	Gives status on CC connection
0Fh	MONITORING_STATUS_TRANS	RC	Alerts about transition in MONITORING_STATUS register
10h	MONITORING_STATUS	RO	Gives status on V _{BUS} voltage monitoring
11h	CC_CONNECTION_STATUS	RO	Gives status on CC connection
12h	HW_FAULT_STATUS_TRANS	RC	Alerts about transition in HW_FAULT_STATUS register
13h	HW_FAULT_STATUS	RO	Gives status on hardware faults
14h to 17h	Reserved	RO	Do not use
18h	CC_CAPABILITY_CTRL	R/W	Allows CC capabilities to be changed
19h to 22h	Reserved	RO	Do not use
23h	RESET_CTRL	R/W	Controls the device reset by software
24h	Reserved	RO	Do not use
25h	VBUS_DISCHARGE_TIME_CTRL	R/W	Allows the V _{BUS} discharge time parameters to be changed
26h	VBUS_DISCHARGE_STATUS	RO	Gives status on V _{BUS} discharge path activation
27h	VBUS_ENABLE_STATUS	RO	Gives status on V _{BUS} power path activation
28h to 2Dh	Reserved	RO	Do not use
2Eh	VBUS_MONITORING_CTRL	R/W	Allows the monitoring conditions of V _{BUS} voltage to be changed
2Fh to 70h	Reserved	RO	Do not use
71h to 74h	SRC_PDO1	R/W	PDO1 capabilities configuration
75h to 78h	SRC_PDO2	R/W	PDO2 capabilities configuration
79h to 7Ch	SRC_PDO3	R/W	PDO3 capabilities configuration
7Dh to 80h	SRC_PDO4	R/W	PDO4 capabilities configuration
81h to 84h	SRC_PDO5	R/W	PDO5 capabilities configuration
85h to 90h	Reserved	RO	Do not use
91h to 94h	SRC_RDO	RO	PDO request status

Table 20. Register access legend

Access code	Expanded name	Description
RO	Read only	Register can be read only
R/W	Read / Write	Register can be read or written
RC	Read and clear	Register can be read and is cleared after read

7 Typical use cases

7.1 Power supply – buck topology

Figure 6. Power supply - buck topology

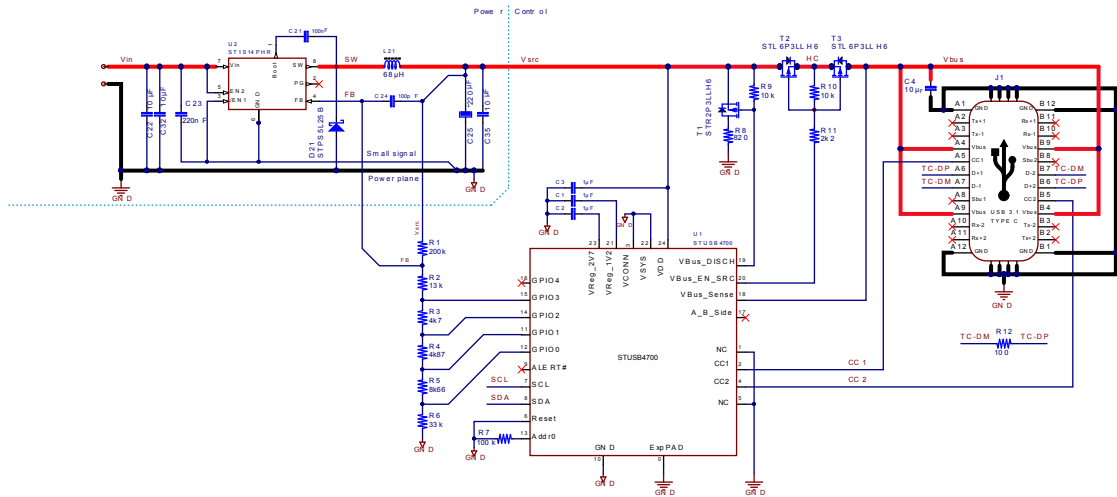

The STUSB4700 offers the possibility to have up to 5 PDOs.

Figure 7. Power supply - buck topology extract

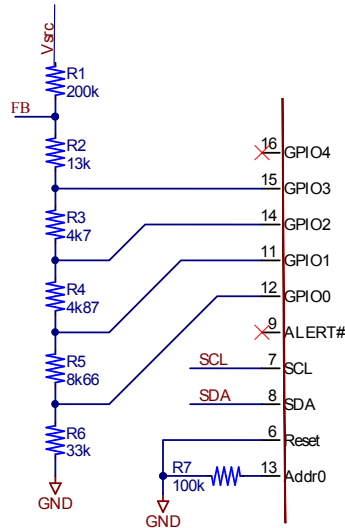

In the above example, the V_{safe5V} is generated by R_1 and the full ladder $R_2+R_3+R_4+R_5+R_6$. When a power delivery negotiation results in a PD contract that is not 5 V (PDO2, PDO3, PDO4 and PDO5), GPIO0, GPIO1, GPIO2 and GPIO3 are asserted (active low), respectively. This shorts R_6 , R_5 , R_4 and R_3 according to the following table.

Table 21. Resistor value

PDO	V _{OUT}	Calculation	Resistor value (ohm)
		R_1	200 k
5	20	$R_2 = R_1 \cdot \frac{1.22}{V_{OUT} - 1.22}$	13 k
4	15	$R_3 = R_1 \cdot \frac{1.22}{V_{OUT} - 1.22} - R_2$	4.7 k
3	12	$R_4 = R_1 \cdot \frac{1.22}{V_{OUT} - 1.22} - R_2 - R_3$	4.87 k
2	9	$R_5 = R_1 \cdot \frac{1.22}{V_{OUT} - 1.22} - R_2 - R_3 - R_4$	8.66 k
1	5	$R_6 = R_1 \cdot \frac{1.22}{V_{OUT} - 1.22} - R_2 - R_3 - R_4 - R_5$	33 k

To implement a different VBUS output voltage for every PDO, the Resistor matrix needs to be calculated using the following formula:

$$VBUS = 1.22 \cdot \frac{R_1}{R_2 + R_3 + R_4 + R_5 + R_6} \quad (1)$$

7.2 Power supply – flyback topology

Figure 8. Flyback topology

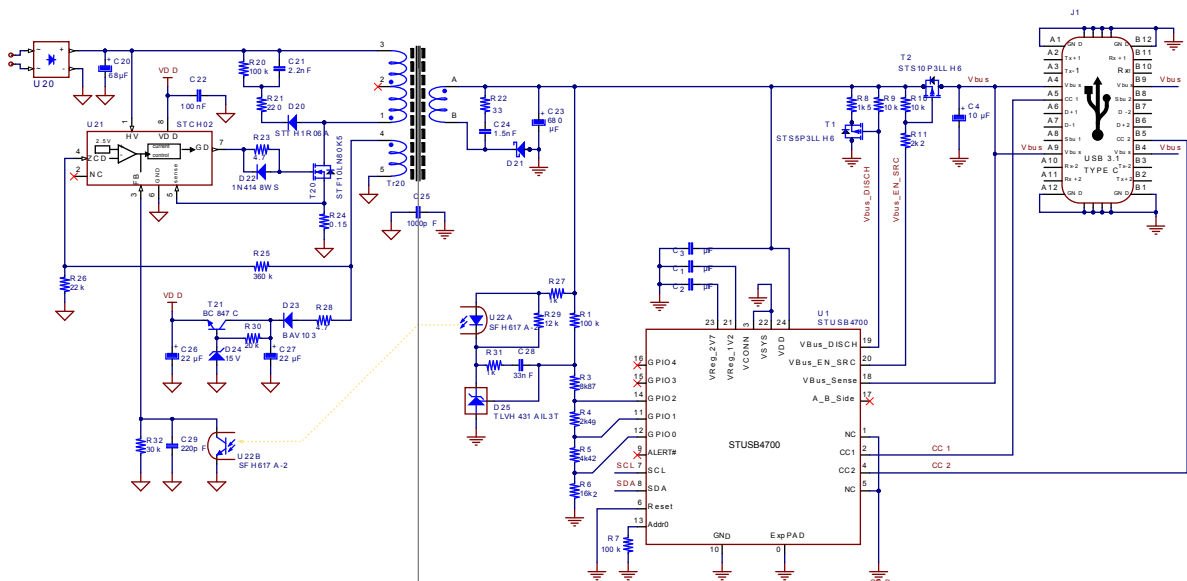

In the above example, only 4 power profiles are used: 5 V, 9 V, 12 V and 15 V.

Figure 9. Flyback topology extract

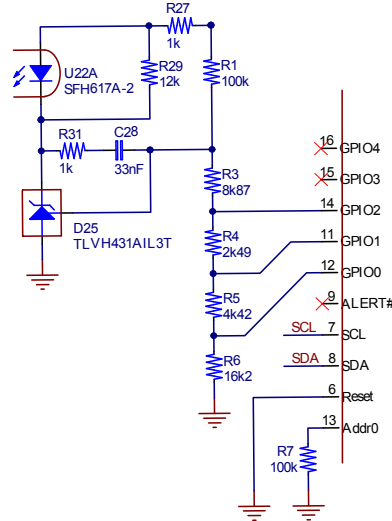

The V_{safe5V} is generated by R_1 and the full ladder $R_3+R_4+R_5+R_6$. When a power delivery negotiation results in a PD contract that is not 5 V (PDO2, PDO3, PDO4), GPIO0, GPIO1 and GPIO2 are asserted (active low), respectively. This shorts R_6 , R_5 , R_4 according to the following table.

Table 22. Resistor value

PDO	V_{OUT}	Calculation	Resistor value (Ω)
		R_1	100 k
4	15	$R_3 = R_1 \cdot \frac{1.24}{V_{\text{OUT}} - 1.24}$	8.87 k
3	12	$R_4 = R_1 \cdot \frac{1.24}{V_{\text{OUT}} - 1.24} - R_3$	2.49 k
2	9	$R_5 = R_1 \cdot \frac{1.24}{V_{\text{OUT}} - 1.24} - R_3 - R_4$	4.42 k
1	5	$R_6 = R_1 \cdot \frac{1.24}{V_{\text{OUT}} - 1.24} - R_3 - R_4 - R_5$	16.2 k

To implement a different V_{BUS} output voltage for every PDO, the Resistor matrix needs to be calculated using the following formula:

$$V_{\text{BUS}} = 1.24 \cdot \frac{R_1}{R_3 + R_4 + R_5 + R_6} \quad (2)$$

8 Electrical characteristics

8.1 Absolute maximum ratings

All voltages are referenced to GND.

Table 23. Absolute maximum ratings

Symbol	Parameter	Value	Unit
V _{DD}	Supply voltage on VDD pin	28	V
V _{SYS}	Supply voltage on V _{SYS} pin	6	V
V _{CC1} V _{CC2}	High voltage on CC pins	22	V
V _{VBUS_EN_SRC} V _{VBUS_SENSE}	High voltage on V _{BUS} pins	28	V
V _{SCL} V _{SDA} V _{ALERT#} V _{RESET} V _{A_B_SIDE} V _{GPIO[4 :0]}	Operating voltage on I/O pins	-0.3 to 6	V
V _{CONN}	V _{CONN} voltage	6	V
T _{STG}	Storage temperature	-55 to 150	°C
T _J	Maximum junction temperature	145	°C
ESD	HBM	4	kV
	CDM	1.5	

8.2 Operating conditions

Table 24. Operating conditions

Symbol	Parameter	Value	Unit
V_{DD}	Supply voltage on V_{DD} pin	4.1 to 22	V
V_{SYS}	Supply voltage on V_{SYS} pin	3.0 to 5.5	V
V_{CC1}, V_{CC2}	CC pins ⁽¹⁾	-0.3 to 5.5	V
$V_{VBUS_EN_SRC}$ V_{VBUS_DISCH} V_{VBUS_SENSE}	High voltage pins	0 to 22	V
V_{SCL}, V_{SDA} $V_{ALERT\#}$ V_{RESET} $V_{A_B_SIDE}$ $V_{GPIO[4 :4]}$	Operating voltage on I/O pins	0 to 4.5	V
V_{CONN}	V_{CONN} voltage	2.7 to 5.5	V
I_{CONN}	V_{CONN} rated current (default = 0.35 A)	0.1 to 0.6	A
T_A	Operating temperature	-40 to 105	°C

1. Transient voltage on CC1 and CC2 pins are allowed to go down to -0.3 during BMC communication from connected devices.

8.3 Electrical and timing characteristics

Unless otherwise specified: $V_{DD} = 5\text{ V}$, $T_A = +25\text{ }^\circ\text{C}$, all voltages are referenced to GND.

Table 25. Electrical characteristics

Symbol	Parameter	Conditions	Min.	Typ.	Max.	Unit
$I_{DD(SRC)}$	Current consumption	Device idle as source (not connected, no communication)				
		V_{SYS} @ 3.3 V	–	158	–	μA
		V_{DD} @ 5.0 V	–	188	–	μA
CC1 and CC2 pins						
I_{P-USB}	CC current sources	CC pin voltage $V_{CC} = -0.3$ to 2.6 V $-40^\circ < T_A < +105^\circ$	-20%	80	+20%	μA
$I_{P-1.5}$			-8%	180	+8%	μA
$I_{P-3.0}$			-8%	330	+8%	μA
V_{CCO}	CC open pin voltage	CC unconnected, $V_{DD}=3.0$ to 5.5 V	2.75	–	–	V
R_{INCC}	CC input impedance	Terminations off	200	–	–	k Ω
$V_{TH0.2}$	Detection threshold 1	Max. R_a detection by source at $I_P = I_{P-USB}$	0.15	0.2	0.25	V
$V_{TH0.4}$	Detection threshold 2	Max. R_a detection by source at $I_P = I_{P-1.5}$	0.35	0.4	0.45	V
$V_{TH0.8}$	Detection threshold 3	Max. R_a detection by source at $I_P = I_{P-3.0}$	0.75	0.8	0.85	V
$V_{TH1.6}$	Detection threshold 4	Max. R_d detection by source at $I_P = I_{P-USB}$ and $I_P = I_{P-1.5}$	1.5	1.6	1.65	V
$V_{TH2.6}$	Detection threshold 5	Max. R_d detection by source at $I_{P-3.0}$, max. CC voltage for connected sink	2.45	2.6	2.75	V
VCONN pin and power switches						
R_{VCONN}	V_{CONN} power path resistance	$I_{VCONN} = 0.2\text{ A}$ $-40\text{ }^\circ\text{C} < T_A < +105\text{ }^\circ\text{C}$	0.25	0.5	0.975	Ω
I_{OCP}	Overcurrent protection	Programmable current limit threshold (from 100 mA to 600 mA by step of 50 mA)	85	100	125	mA
			300	350	400	
			550	600	650	
V_{OVP}	Overvoltage protection on CC output pins		5.9	6	6.1	V
V_{UVP}	Undervoltage protection on VCONN input pin	Low UVLO threshold	2.6	2.65	2.7	V
		High UVLO threshold (default)	4.6	4.65	4.8	
VDD pin monitoring						
V_{DDOVLO}	Overvoltage lockout	OVLO threshold detection enabled, VDD pin supplied	5.8	6	6.2	V
V_{DDUVLO}	Undervoltage lockout	UVLO threshold detection enabled, VDD pin supplied	3.8	3.9	4.0	V

Symbol	Parameter	Conditions	Min.	Typ.	Max.	Unit
VBUS_SENSE pin monitoring and driving						
V _{THUSB}	V _{BUS} presence threshold (UVLO)	V _{SYS} =3.0 to 5.5 V	3.8	3.9	4	V
V _{TH0V}	V _{BUS} safe 0V threshold (vSafe0V)	V _{SYS} =3.0 to 5.5 V	0.5	0.6	0.7	V
R _{DISUSB}	V _{BUS} discharge resistor		600	700	800	Ω
T _{DISUSB0V}	V _{BUS} discharge time to 0 V	Coefficient T _{DISPAR0V} programmable by NVM, default T _{DISPAR0V} = 2, T _{DISUSB0V} = 168 ms	70 *T _{DISPAR0V}	84 *T _{DISPAR0V}	100 *T _{DISPAR0V}	ms
T _{DISUSBPDO}	V _{BUS} transition discharge time to new PDO	Coefficient T _{DISPARPDO} programmable by NVM, default T _{DISPARPDO} = 12, T _{DISUSBPDO} = 288 ms	20 *T _{DISPARPDO}	24 *T _{DISPARPDO}	28 *T _{DISPARPDO}	ms
V _{MONUSBH}	V _{BUS} monitoring high voltage limit	Coefficient V _{SHUSBH} programmable by NVM from 1% to 15% of V _{BUS} by step of 1%, default V _{MONUSBH} = V _{BUS} +12% (PDO1) V _{MONUSBH} = V _{BUS} +10% (PDO2, PDO3, PDO4) V _{MONUSBH} = V _{BUS} +8% (PDO5)	–	V _{BUS} +5% +V _{SHUSBH}	–	V
V _{MONUSBL}	V _{BUS} monitoring low voltage limit	Coefficient V _{SHUSBL} programmable by NVM from 1% to 15% of V _{BUS} by step of 1%, default V _{MONUSBL} = V _{BUS} -10% (all PDOs)	–	V _{BUS} -5% -V _{SHUSBL}	–	V
Digital input/output (SCL, SDA, ALERT#, A_B_SIDE, RESET)						
V _{IH}	High level input voltage		1.2	–	–	V
V _{IL}	Low level input voltage		–	–	0.35	V
V _{OL}	Low level output voltage	loh = 3 mA	–	–	0.4	V
20 V open-drain outputs (VBUS_EN_SRC)						
V _{OL}	Low level output voltage	loh = 3 mA	–	–	0.4	V

9 Package information

In order to meet environmental requirements, ST offers these devices in different grades of **ECOPACK** packages, depending on their level of environmental compliance. ECOPACK specifications, grade definitions and product status are available at: www.st.com. ECOPACK is an ST trademark.

9.1 QFN24 EP 4x4 mm package information

Figure 10. QFN24 EP 4x4 mm package outline

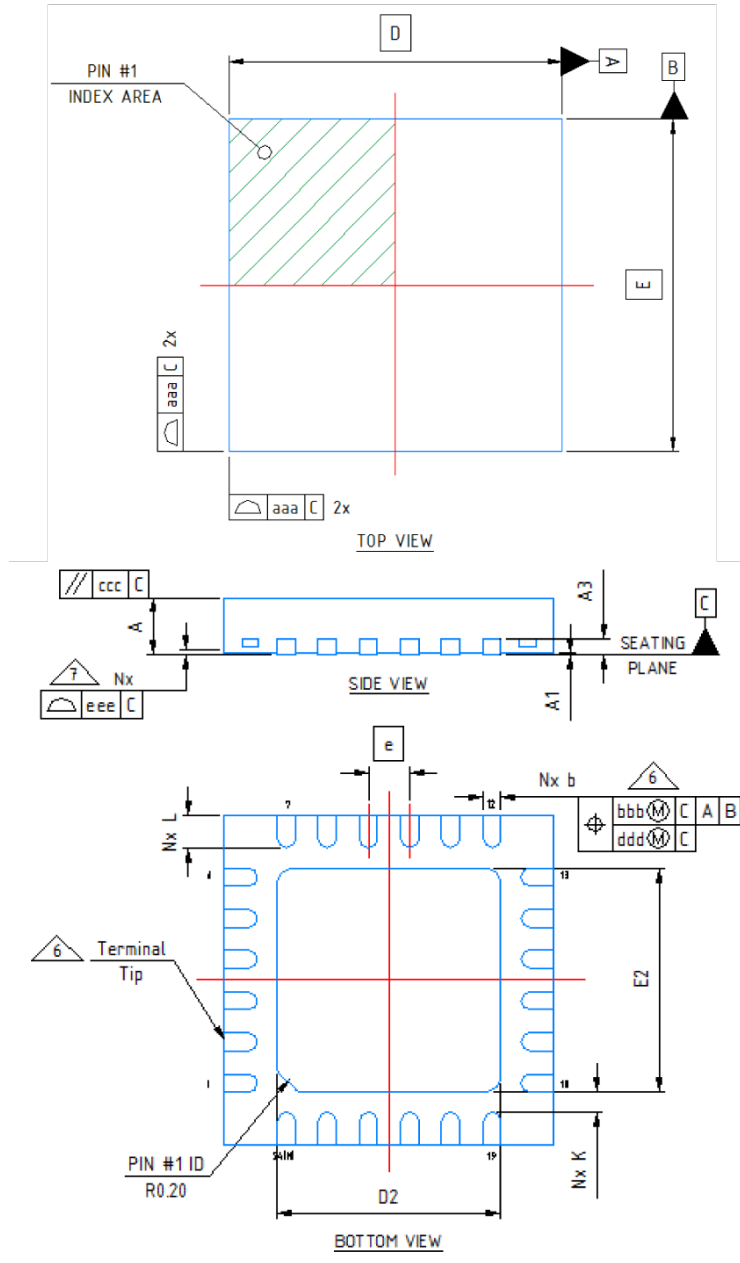

Table 26. QFN24 EP 4x4 mm package mechanical data

Symbol	mm		
	Min.	Typ.	Max.
A	0.80	0.90	1.00
A1	0.00	0.02	0.05
A3		0.20 Ref.	
b	0.18	0.25	0.30
D	3.90	4.00	4.10
D2	2.55	2.70	2.80
E	3.90	4.00	4.10
E2	2.55	2.70	2.80
e		0.50	
k	0.20	-	-
L	0.30	0.40	0.50

Table 27. Tolerance of form and position

Symbol	mm
aaa	0.05
bbb	0.10
ccc	0.10
ddd	0.05
eee	0.08

Figure 11. QFN24 EP 4x4 mm recommended footprint

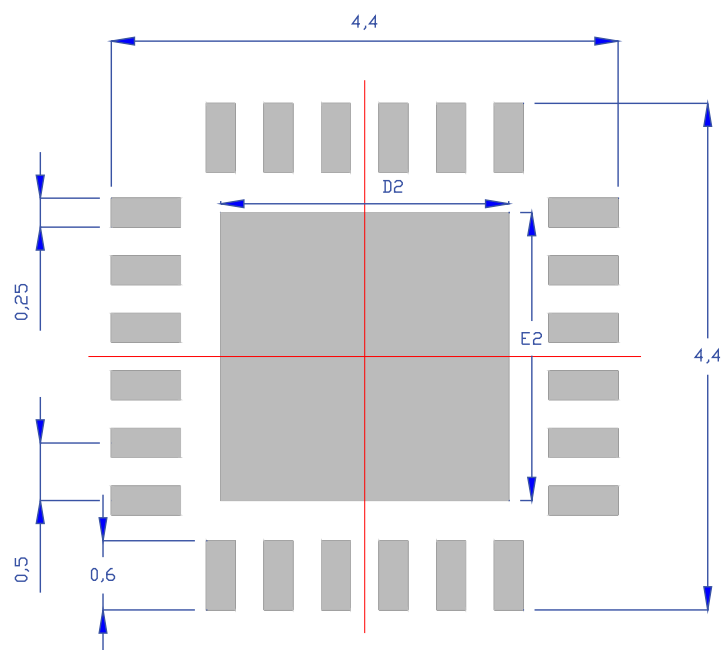

9.2 QFN24 EP 4x4 mm wettable flank package information

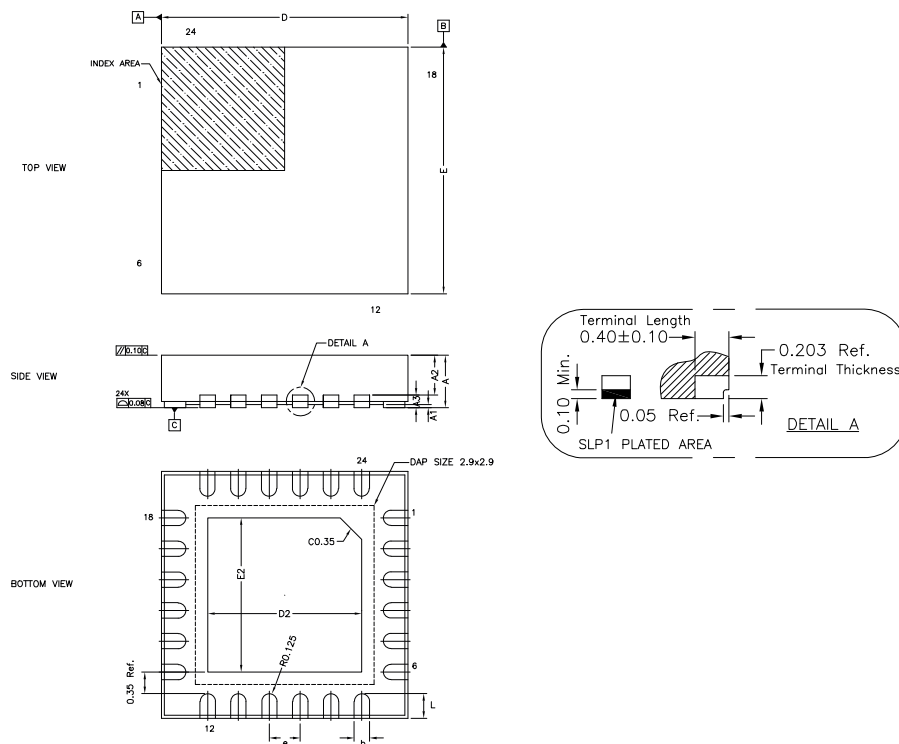
Figure 12. QFN24 EP 4x4 mm wettable flank package outline

Table 28. QFN24 EP 4x4 mm wettable flank mechanical data

Symbol	mm		
	Min.	Typ.	Max.
A	0.80	0.85	0.90
A1	0.00	0.05	
A2		0.65	
A3		0.203 REF	
B	0.20	0.25	0.30
D	3.90	4.00	4.10
E	3.90	4.00	4.10
D2	2.40	2.50	2.60
E2	2.40	2.50	2.60
e		0.50 BSC	
L	0.30	0.40	0.50

9.3 Packing information

Figure 13. Reel information

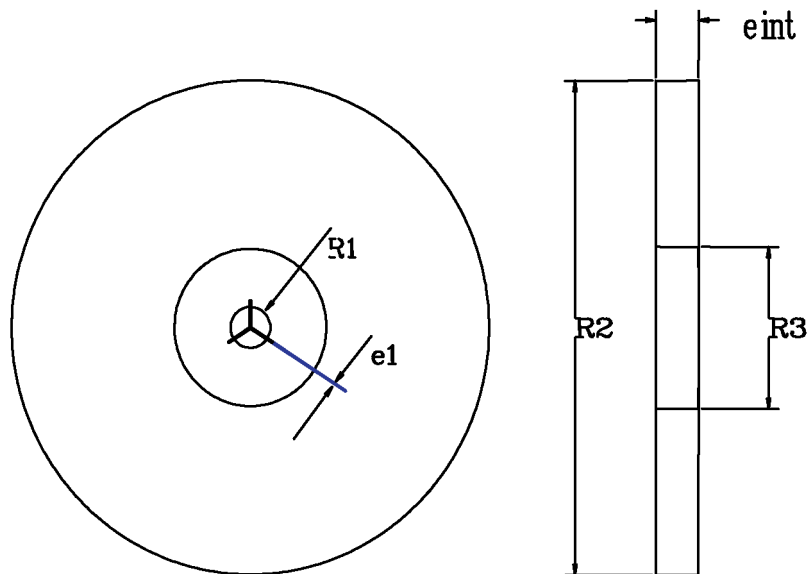

Table 29. Tape dimensions

Package	Pitch	Carrier width	Reel
QFN 4x4 - 24L	8 mm	12 mm	13"

10 Thermal information

Table 30. Thermal information

Symbol	Parameter	Value	Unit
R _{θJA}	Junction-to-ambient thermal resistance	37	°C/W
R _{θJC}	Junction-to-case thermal resistance	5	

11 Terms and abbreviations

Table 31. List of terms and abbreviations

Term	Description
Accessory modes	Audio adapter accessory mode. It is defined by the presence of Ra/Ra on the CC1/CC2 pins.
	Debug accessory mode. It is defined by the presence of Rd/Rd on CC1/CC2 pins in source power role or Rp/Rp on CC1/CC2 pins in sink power role.
DFP	Downstream facing port, associated with the flow of data in a USB connection. Typically, the ports on a host or the ports on a hub to which devices are connected. In its initial state, the DFP sources V_{BUS} and V_{CONN} and supports data.
DRP	Dual-role port. A port that can operate as either a source or a sink. The port role may be changed dynamically.
Sink	Port asserting Rd on the CC pins and consuming power from the V_{BUS} ; most commonly a device.
Source	Port asserting Rp on the CC pins and providing power over the V_{BUS} ; usually a host or hub DFP.
UFP	Upstream facing port, specifically associated with the flow of data in a USB connection. The port on a device or a hub that connects to a host or the DFP of a hub. In its initial state, the UFP sinks the V_{BUS} and supports data.

12 Ordering information

Table 32. Ordering information

Order code	AEC-Q100	Package	Marking	Temperature range
STUSB4700QTR	No	QFN24 EP 4x4 mm	4700	-40 °C to 105 °C
STUSB4700YQTR	Yes	QFN24 EP 4x4 mm Wettable flanks	4700Y	

Revision history

Table 33. Document revision history

Date	Version	Changes
24-Jan-2017	1	Initial release.
22-Mar-2017	2	Updated comments columns in Table 7: "GPIO1 (pin #11) configuration" and Table 8: "GPIO2 (pin #14) – GPIO3 (pin #15) – GPIO4 (pin #16) configuration", and ESD parameter description in Table 18: "Absolute maximum rating". In Table 19: "Operating conditions " replaced VVBUS_EN_SNK with VVBUS_DISCH. Replaced Figure 6: "Power supply - buck topology" with a new figure. Minor changes throughout the document.
06-Dec-2017	3	On cover page: - updated title description - updated feature regarding protections - added feature regarding Automotive grade availability - updated feature regarding Certification test ID - updated Table 1: "Device summary table" Updated Section 7.1 Power supply – buck topology Updated Section 7.2 Power supply – flyback topology Added Section 9.2 QFN24 EP 4x4 mm wettable flank package information
12-Jun-2018	4	Minor text changes
16-Oct-2019	5	Updated Table 13. Factory NVM setting. Updated Figure 6. Power supply - buck topology and Figure 8. Flyback topology.
06-Apr-2021	6	Updated Section 9.1 QFN24 EP 4x4 mm package information.
11-Nov-2022	7	Updated Section 9.2 QFN24 EP 4x4 mm wettable flank package information.
29-Aug-2023	8	Updated Figure 6 and Figure 8 .

Contents

1	Functional description	2
2	Inputs/outputs	3
2.1	Pinout	3
2.2	Pin list	4
2.3	Pin description	6
2.3.1	CC1 / CC2	6
2.3.2	RESET	6
2.3.3	I ² C interface pins	6
2.3.4	A_B_SIDE	6
2.3.5	VBUS_SENSE	6
2.3.6	VBUS_EN_SRC	6
2.3.7	V _{sys}	6
2.3.8	VDD	7
2.3.9	GND	7
2.3.10	VVAR_ADDR0	7
2.3.11	VREG_2V7	7
2.3.12	VREG_1V2	7
2.3.13	VBUS_DISCH	7
2.3.14	VCONN	7
2.3.15	GPIO [4:0]	8
3	Block descriptions	9
3.1	CC interface	9
3.2	BMC	9
3.3	Protocol layer	9
3.4	Policy engine	9
3.5	Device policy manager	9
3.6	VBUS power path control	9
3.6.1	VBUS monitoring	9
3.6.2	VBUS discharge	10
3.6.3	VBUS power path assertion	10
3.7	High voltage protection	11
3.8	Hardware fault management	11
3.9	Accessory mode detection	11
3.9.1	Audio accessory mode detection	11
3.9.2	Debug accessory mode detection	11

4	User-defined start-up configuration	13
4.1	Parameter overview	13
4.2	PDO – voltage configuration in NVM	14
4.3	PDO – current configuration in NVM	14
4.4	Monitoring configuration in NVM	14
4.5	Factory settings	15
5	I²C interface	16
5.1	Read and write operations	16
5.2	Timing specifications	17
6	I²C register map	19
7	Typical use cases	21
7.1	Power supply – buck topology	21
7.2	Power supply – flyback topology	22
8	Electrical characteristics	24
8.1	Absolute maximum ratings	24
8.2	Operating conditions	25
8.3	Electrical and timing characteristics	26
9	Package information	28
9.1	QFN24 EP 4x4 mm package information	29
9.2	QFN24 EP 4x4 mm wettable flank package information	31
9.3	Packing information	32
10	Thermal information	33
11	Terms and abbreviations	34
12	Ordering information	35
	Revision history	36

List of tables

Table 1.	Pin function list	4
Table 2.	Legend	5
Table 3.	I ² C interface pin list	6
Table 4.	USB data mux select	6
Table 5.	GPIO0 (pin #12) configuration	8
Table 6.	GPIO1 (pin #11) configuration	8
Table 7.	GPIO2 (pin #14) – GPIO3 (pin #15) – GPIO4 (pin #16) configuration	8
Table 8.	Conditions for VBUS power path assertion	10
Table 9.	The orientation detection.	12
Table 10.	PDO configurations in NVM.	13
Table 11.	PDO NVM voltage configuration	14
Table 12.	PDO NVM current configuration	14
Table 13.	Factory NVM setting.	15
Table 14.	Device address format	16
Table 15.	Register address format	16
Table 16.	Register data format.	16
Table 17.	I ² C timing parameters - VDD = 5 V.	17
Table 18.	Register access legend	19
Table 19.	STUSB4700 register map overview	19
Table 20.	Register access legend	20
Table 21.	Resistor value	22
Table 22.	Resistor value	23
Table 23.	Absolute maximum ratings	24
Table 24.	Operating conditions	25
Table 25.	Electrical characteristics	26
Table 26.	QFN24 EP 4x4 mm package mechanical data	30
Table 27.	Tolerance of form and position	30
Table 28.	QFN24 EP 4x4 mm wettable flank mechanical data	31
Table 29.	Tape dimensions	32
Table 30.	Thermal information	33
Table 31.	List of terms and abbreviations	34
Table 32.	Ordering information.	35
Table 33.	Document revision history	36

List of figures

Figure 1.	Functional block diagram	2
Figure 2.	Pin connections (top view)	3
Figure 3.	Read operation.	16
Figure 4.	Write operation.	17
Figure 5.	I ² C timing diagram.	18
Figure 6.	Power supply - buck topology.	21
Figure 7.	Power supply - buck topology extract.	21
Figure 8.	Flyback topology.	22
Figure 9.	Flyback topology extract	23
Figure 10.	QFN24 EP 4x4 mm package outline	29
Figure 11.	QFN24 EP 4x4 mm recommended footprint	30
Figure 12.	QFN24 EP 4x4 mm wettable flank package outline	31
Figure 13.	Reel information	32

IMPORTANT NOTICE – READ CAREFULLY

STMicroelectronics NV and its subsidiaries (“ST”) reserve the right to make changes, corrections, enhancements, modifications, and improvements to ST products and/or to this document at any time without notice. Purchasers should obtain the latest relevant information on ST products before placing orders. ST products are sold pursuant to ST’s terms and conditions of sale in place at the time of order acknowledgment.

Purchasers are solely responsible for the choice, selection, and use of ST products and ST assumes no liability for application assistance or the design of purchasers’ products.

No license, express or implied, to any intellectual property right is granted by ST herein.

Resale of ST products with provisions different from the information set forth herein shall void any warranty granted by ST for such product.

ST and the ST logo are trademarks of ST. For additional information about ST trademarks, refer to www.st.com/trademarks. All other product or service names are the property of their respective owners.

Information in this document supersedes and replaces information previously supplied in any prior versions of this document.

© 2023 STMicroelectronics – All rights reserved