

PART NO SEE NOTE 3	PLATING
71363-102 71363-102LF	0.38um/15u" GOLD OR GXT ON CONTACT AREA OVER 1.27um/50u" Ni (SEE NOTE 7)
71363-202 71363-202LF	0.76um/30u" GOLD OR GXT ON CONTACT OVER 1.27um/50u" Ni (SEE NOTE 7)
71363-302 71363-302LF	2.54um/100u" MATTE TIN PLATING

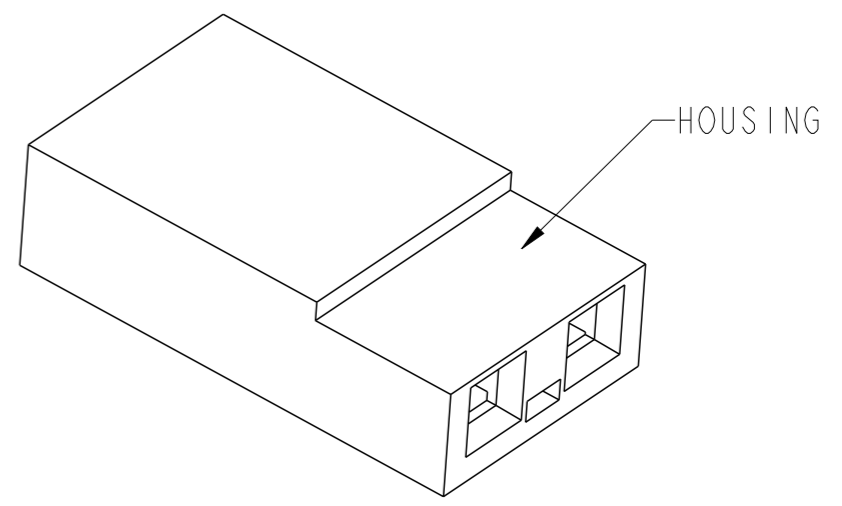

- NOTE:
- MATERIAL
HOUSING : 30% GLASS FILLED POLYESTER
FLAME RETARDANT PER UL 94V-0
COLOR : BLACK
 - TERMINAL : PHOSPHOR BRONZE
PLATING : REFER TO CHART
 - PRODUCT DESCRIPTION CODE:
XXXXX - XXXLF
 - LEAD FREE (SEE NOTE 4 & 6)
 - EXTENSION NUMBER
 - CONTACT AREA PLATING
 - BASE NUMBER
 - 71363-XXXLF IS THE SAME AS 71363-XXX.
SUFFIX 'LF' IS ADDED FOR EASY LEAD FREE IDENTIFICATION.
 - THE HOUSING WILL WITHSTAND EXPOSURE TO 200°C PEAK TEMPERATURE FOR 10 SECONDS IN A CONVECTION, INFRA-RED OR VAPOR PHASE REFLOW OVEN.
 - THIS PRODUCT MEETS EUROPEAN UNION DIRECTIVES AND OTHER COUNTRY REGULATIONS AS DESCRIBED IN GS-22-008.
 - PLATING OPTION:
MAY BE EITHER GOLD OR GXT PLATED AT MANUFACTURER'S OPTION.

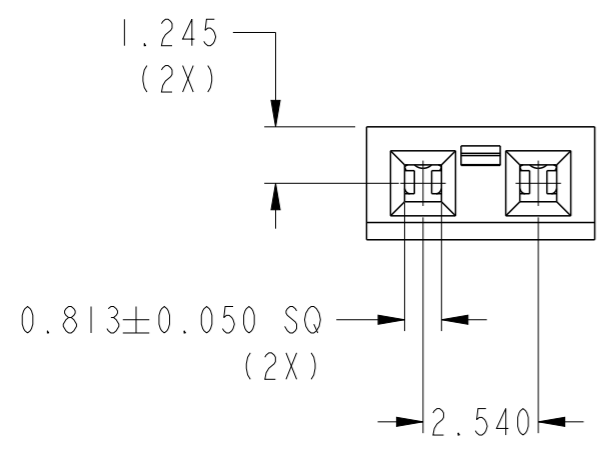
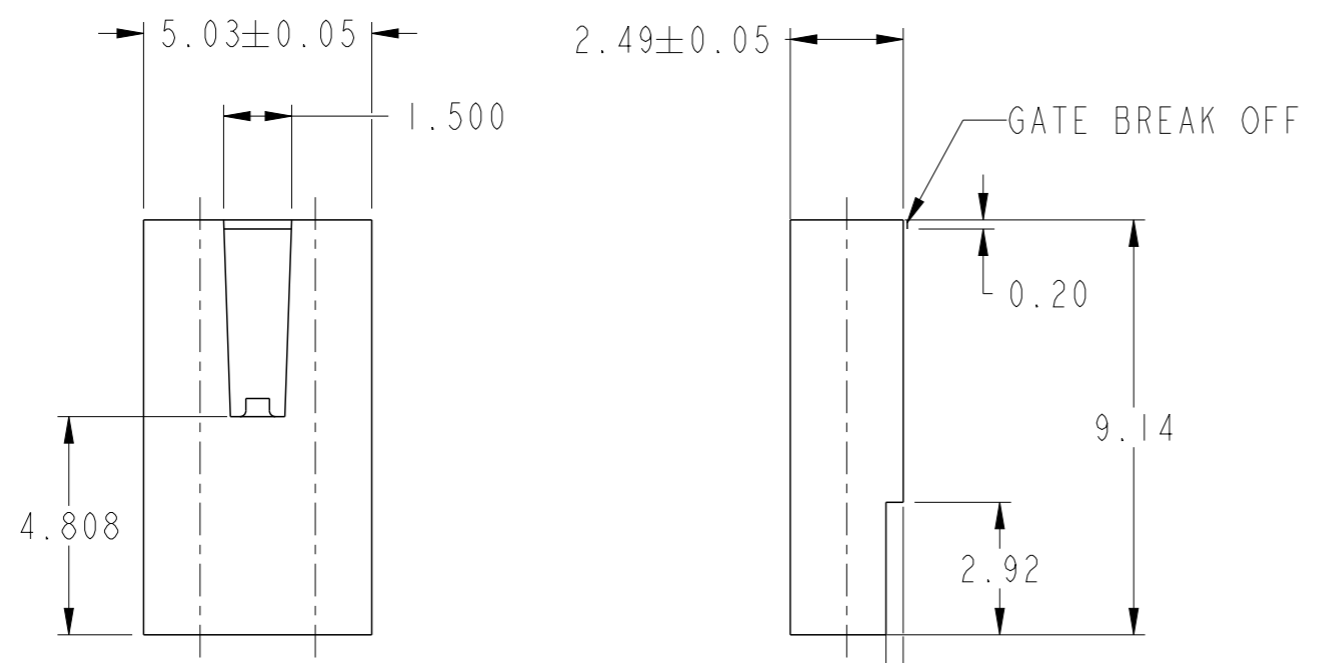

spec ref	-	dr	Louis Ng	2010/10/11	projection	MM	size	A3	scale	6:1	
tolerance std	ISO 406 ISO 1101	eng	Guo-Min Sun	2013/05/15			ecn no	ELX-N-14400-1			
TOLERANCES UNLESS OTHERWISE SPECIFIED		chr	-	-			product family	JUMPER	rel level	Released	
surface	ISO 1302	appr	Rick Bian	2013/05/26			dwg no	71363		rev	K
linear	0.X ±0.35 0.XX ±0.25 0.XXX ±0.10	www.fci.com		cat. no.	-		Product - Customer Drw		sheet 1 of 1		
angular	0° ±2°										

Copyright FCI.