

GLASS PASSIVATED BRIDGE RECTIFIERS

REVERSE VOLTAGE - 50 to 1000Volts
FORWARD CURRENT - 10.0 Amperes

FEATURES

- Surge overload rating -220 amperes peak
- Ideal for printed circuit board
- Reliable low cost construction utilizing molded plastic technique
- Plastic material has U/L flammability classification 94V-0
- Mounting position:Any

GBU

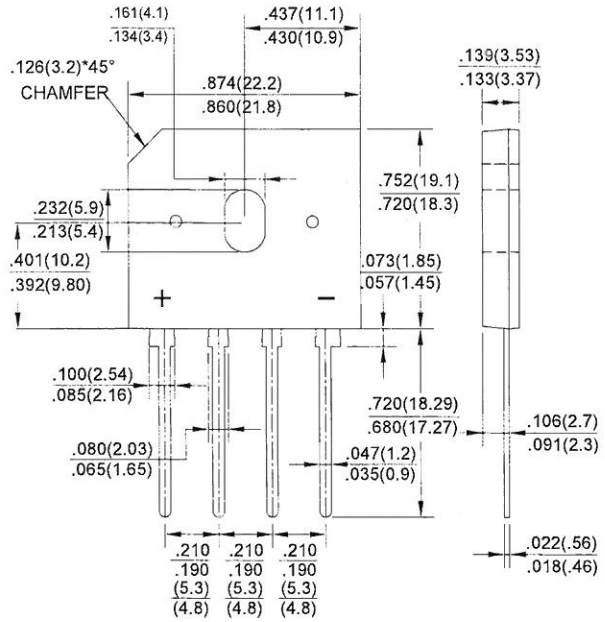

Dimensions in inches and (millimeters)

MAXIMUM RATINGS AND ELECTRICAL CHARACTERISTICS

Rating at 25°C ambient temperature unless otherwise specified.

Single phase, half wave ,60Hz, resistive or inductive load.

For capacitive load, derate current by 20%

CHARACTERISTICS	SYMBOL	GBU 10005	GBU 1001	GBU 1002	GBU 1004	GBU 1006	GBU 1008	GBU 1010	UNIT	
Maximum Recurrent Peak Reverse Voltage	V _{RRM}	50	100	200	400	600	800	1000	V	
Maximum RMS Voltage	V _{RMS}	35	70	140	280	420	560	700	V	
Maximum DC Blocking Voltage	V _{DC}	50	100	200	400	600	800	1000	V	
Maximum Average Forward (with heatsink Note 2) Rectified Current @ T _c =100°C (without heatsink)	I _(AV)	15				10.0				A
Peak Forward Surge Current 8.3ms Single Half Sine-Wave Super Imposed on Rated Load (JEDEC Method)	I _{FSM}					220				A
Maximum Forward Voltage at 5.0A DC	V _F					1.0				V
Maximum DC Reverse Current @ T _J =25°C at Rated DC Blocking Voltage @ T _J =125°C	I _R					10.0				µA
I ² t Rating for Fusing (t<8.3ms)	I ² t					200				A ² s
Typical Junction Capacitance Per Element (Note1)	C _J					70				pF
Typical Thermal Resistance	R _{θJC}					2.2				°C/W
Operating Temperature Range	T _J					-55 to +150				°C
Storage Temperature Range	T _{STG}					-55 to +150				°C

NOTES: 1.Measured at 1.0MHz and applied reverse voltage of 4.0V DC.

2.Device mounted on 100mm*100mm*1.6mm Cu plate heatsink.

3.The typical data above is for reference only(典型值仅供参考).

FIG.1-MAXIMUM FORWARD SURGE CURRENT

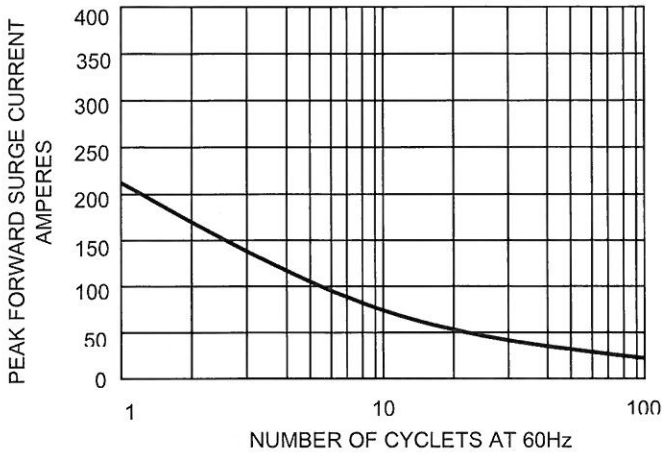

FIG.2- DERATING CURVE
OUTPUT RECTIFIED CURRENT

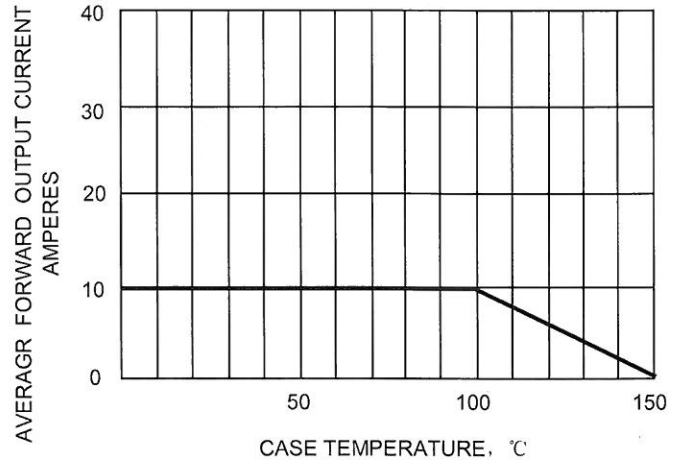

FIG.3-TYPICAL FORWARD CHARACTERISTICS

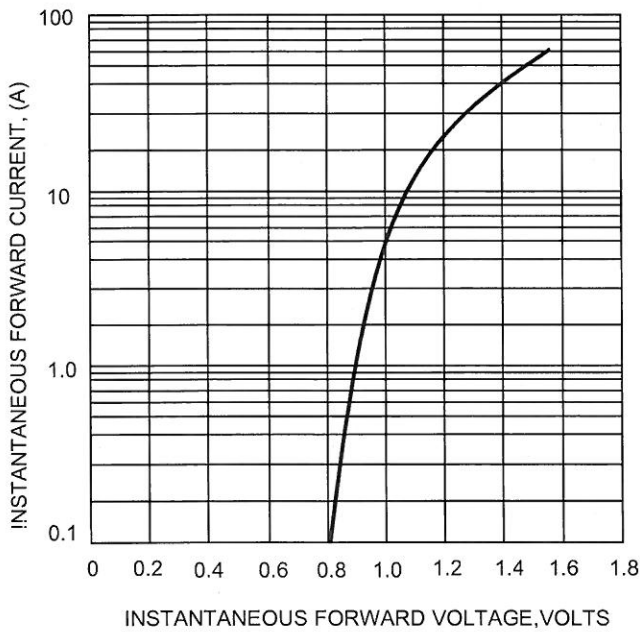
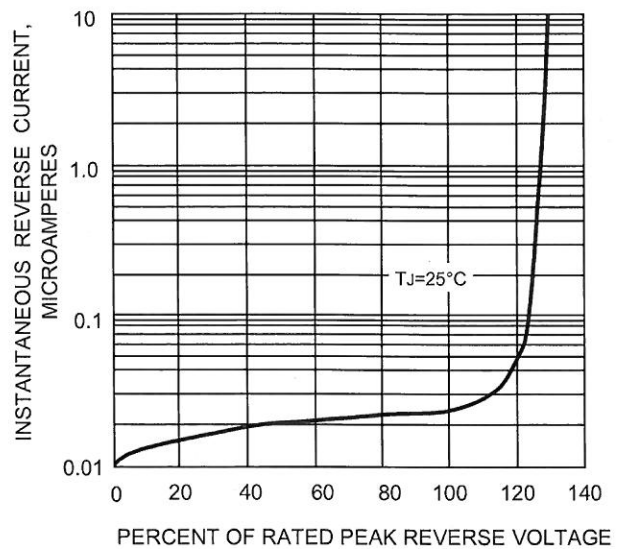

FIG.4-TYPICAL REVERSE CHARACTERISTICS



The curve graph is for reference only, can't be the basis for judgment(曲线图仅供参考)!