

PULL OUT DIRECTION

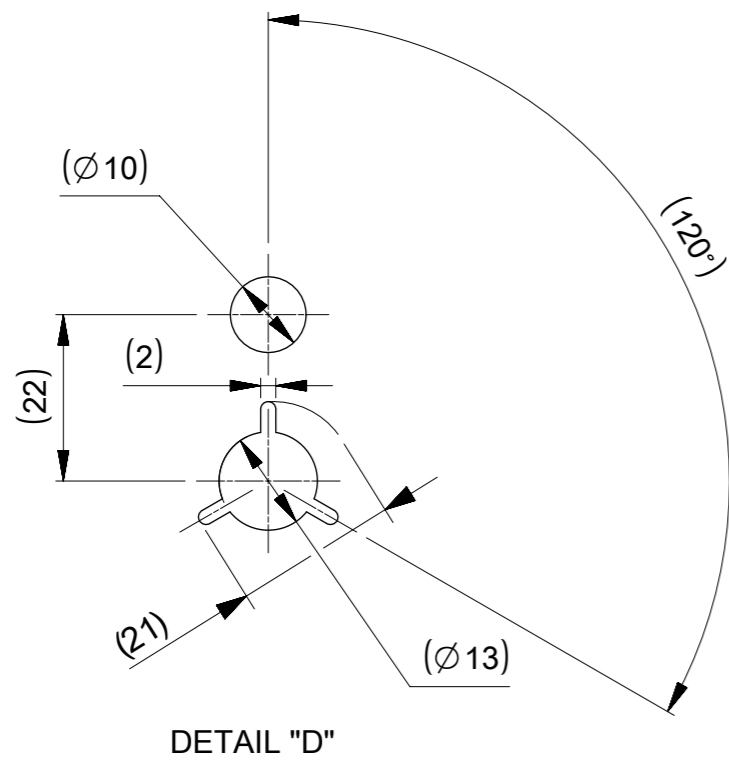

NOTES

1. RE DETAILED DIMENSION, SEE PRODUCT DRAWING.
2. NUMBER OF CONNECTORS : 3300 PCS/REEL.
3. LEAD TAPE LENGTH.

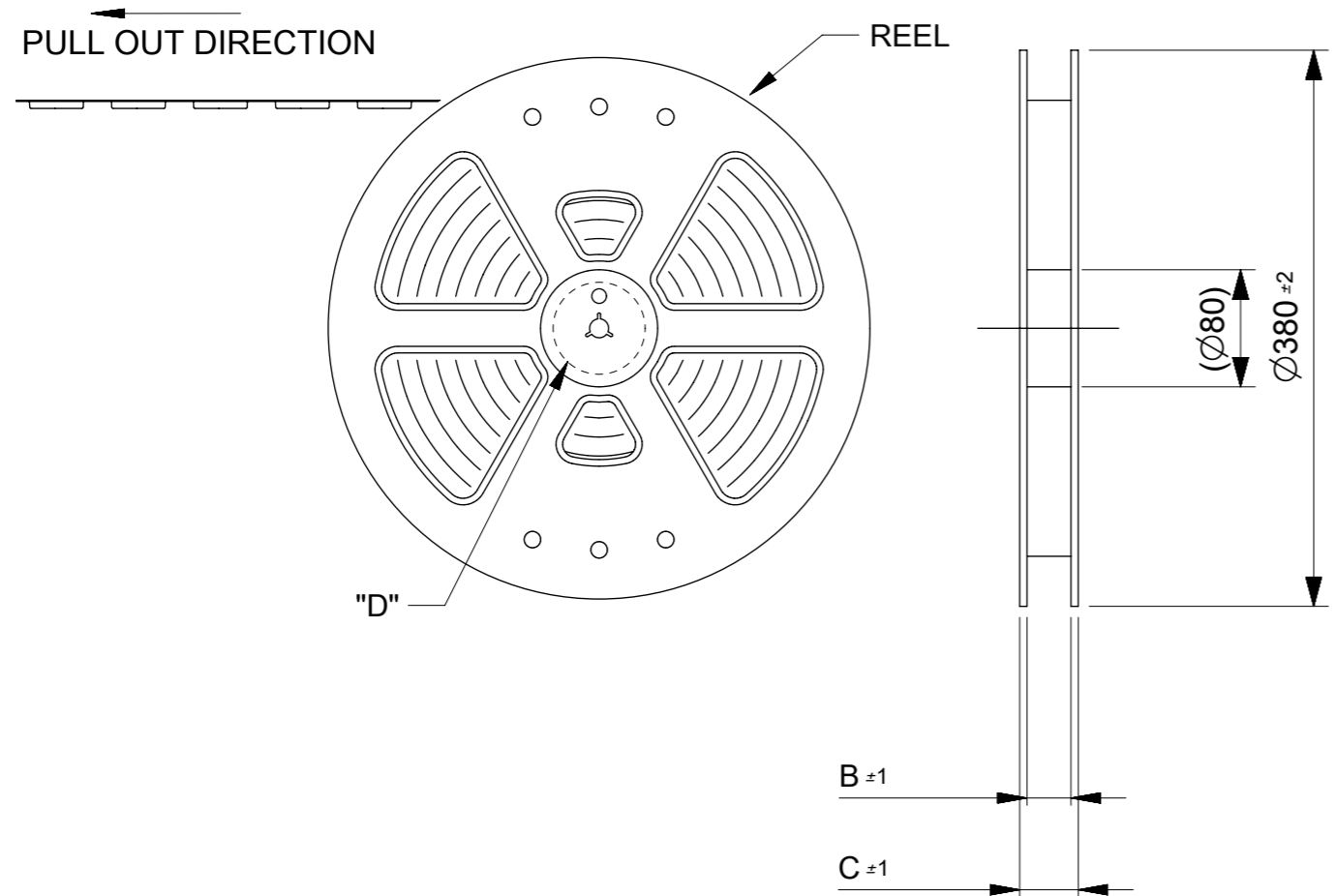
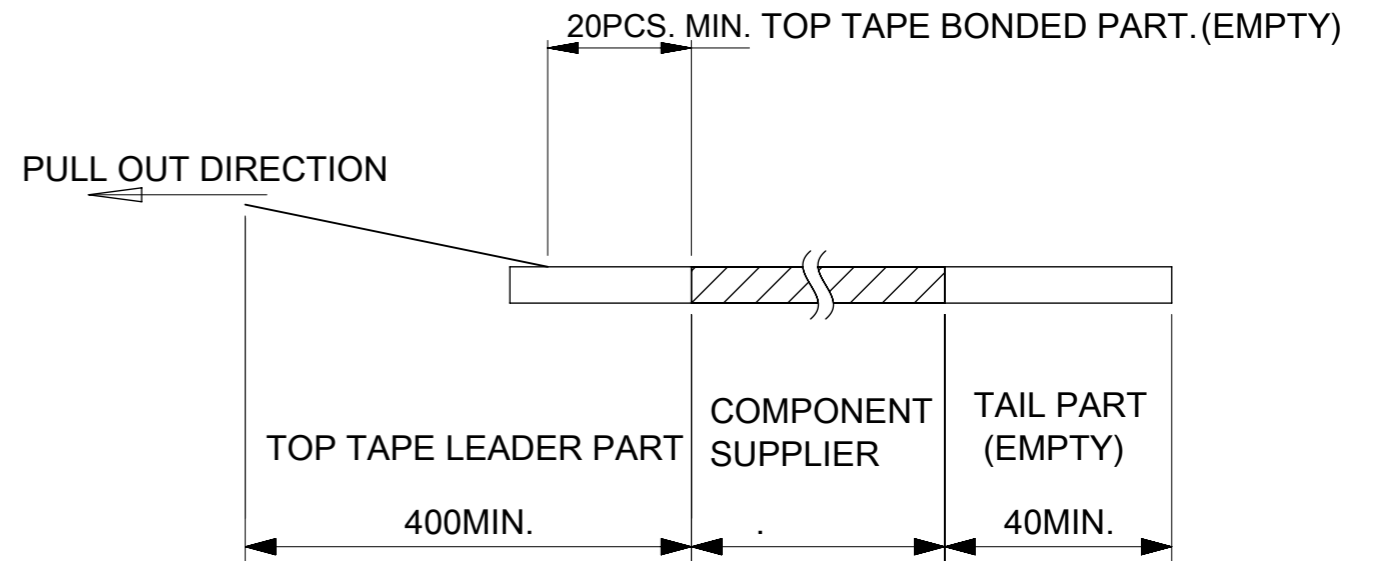

4. TOP TAPE PEEL FORCE IS DEFINED BY IEC60286-3
5. MATERIAL
CARRER TAPE :POLYSTYRENE
TOP TAPE :PET , OTHER
REEL :POLYSTYRENE(PS)(RECYCLE MATERIAL CONTAINED)
6. ELV AND RoHS COMPLIANT

MODEL NO. 2039550**1

THIS DRAWING CONTAINS INFORMATION THAT IS PROPRIETARY TO MOLEX ELECTRONIC TECHNOLOGIES, LLC AND SHOULD NOT BE USED WITHOUT WRITTEN PERMISSION		CURRENT REV DESC:		molex	
DIMENSION UNITS	SCALE				
mm	1:1			0.4 FLOATING BB REC EMBOSSTP PKG.	
GENERAL TOLERANCES (UNLESS SPECIFIED)		EC NO: 600824		PRODUCT CUSTOMER DRAWING	
ANGULAR TOL	± °	DRWN: STERUKI	2018/06/26	DOCUMENT NUMBER	
4 PLACES	±	CHK'D: KSASAKI	2018/06/29	2039550000	
3 PLACES	±	APPR: TKUSUHARA01	2018/06/29	DOC TYPE	DOC PART
2 PLACES	±	INITIAL REVISION:		PSD	001
1 PLACE	±	DRWN: STERUKI	2018/04/27	REVISION	
0 PLACES	±	APPR: TKUSUHARA01	2018/06/22	A1	
DRAFT WHERE APPLICABLE MUST REMAIN WITHIN DIMENSIONS		THIRD ANGLE PROJECTION	DRAWING	SERIES	MATERIAL NUMBER
			A3-SIZE	203955	CUSTOMER
				SEE CHART	SHEET NUMBER
				1 OF 3	

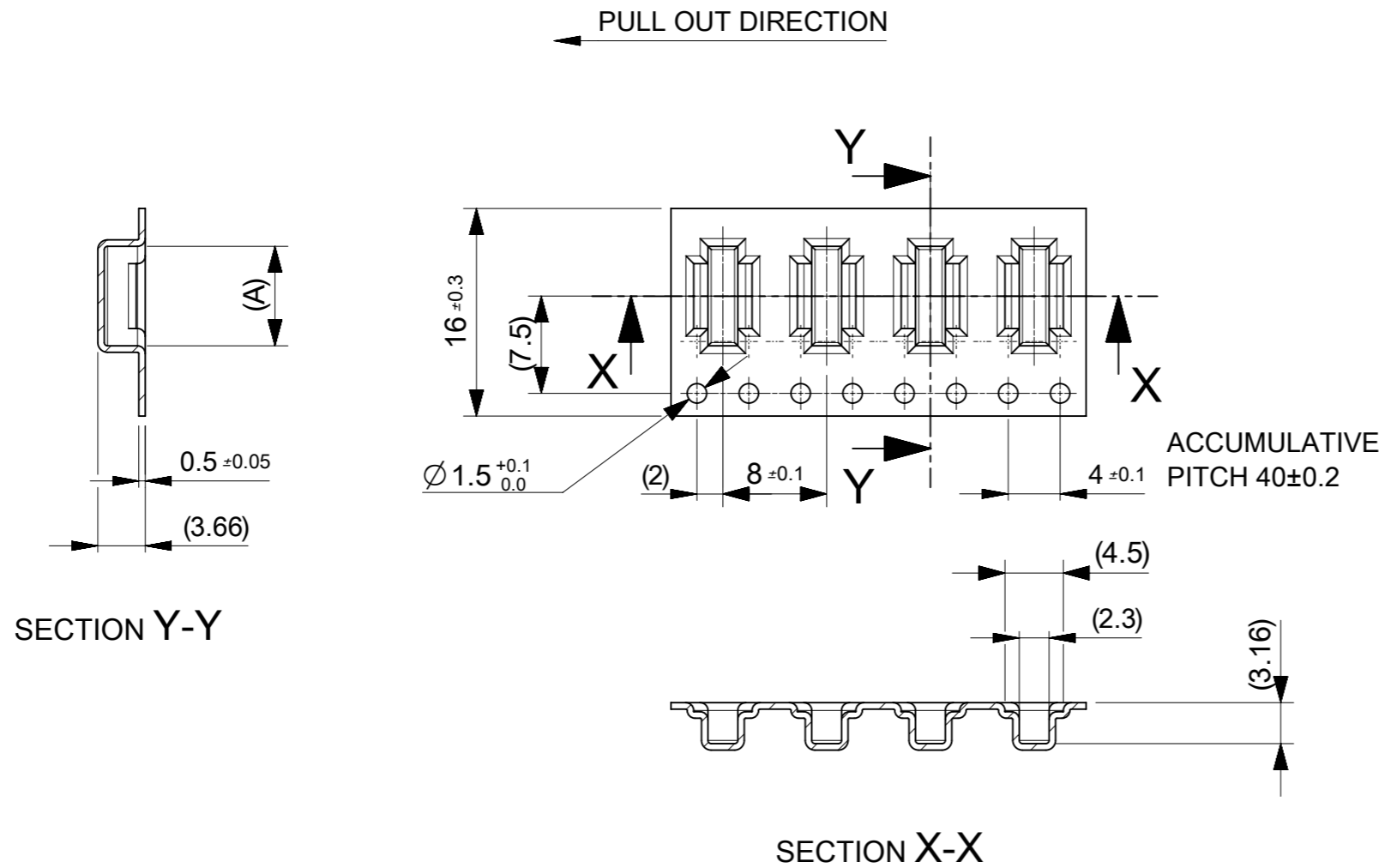

16	21.4	17.4	7.67	2039550301	○	---	30
			5.67	2039550201	---	---	20
キャリアテープ幅 CARRIER TAPE WIDTH	C	B	(A)	MATERIAL No.	HIGH VOL. TOOL	LOW VOL. TOOL	CIRCUIT
					SAMPLE PREPARATION		

THIS DRAWING CONTAINS INFORMATION THAT IS PROPRIETARY TO MOLEX ELECTRONIC TECHNOLOGIES, LLC AND SHOULD NOT BE USED WITHOUT WRITTEN PERMISSION

DIMENSION UNITS mm	SCALE 2:1	CURRENT REV DESC:		molex
GENERAL TOLERANCES (UNLESS SPECIFIED)		EC NO: 600824		
ANGULAR TOL ± °		DRWN: STERUKI	2018/06/26	0.4 FLOATING BB REC EMBOSSTP PKG.
4 PLACES ±		CHK'D: KSASAKI	2018/06/29	
3 PLACES ±		APPR: TKUSUHARA01	2018/06/29	PRODUCT CUSTOMER DRAWING
2 PLACES ±		INITIAL REVISION:		DOCUMENT NUMBER
1 PLACE ±		DRWN: STERUKI	2018/04/27	2039550000
0 PLACES ±		APPR: TKUSUHARA01	2018/06/22	DOC TYPE
DRAFT WHERE APPLICABLE MUST REMAIN WITHIN DIMENSIONS	THIRD ANGLE PROJECTION	DRAWING	SERIES	DOC PART
		A3-SIZE	203955	REVISION
				MATERIAL NUMBER
				CUSTOMER
				SHEET NUMBER
				2 OF 3

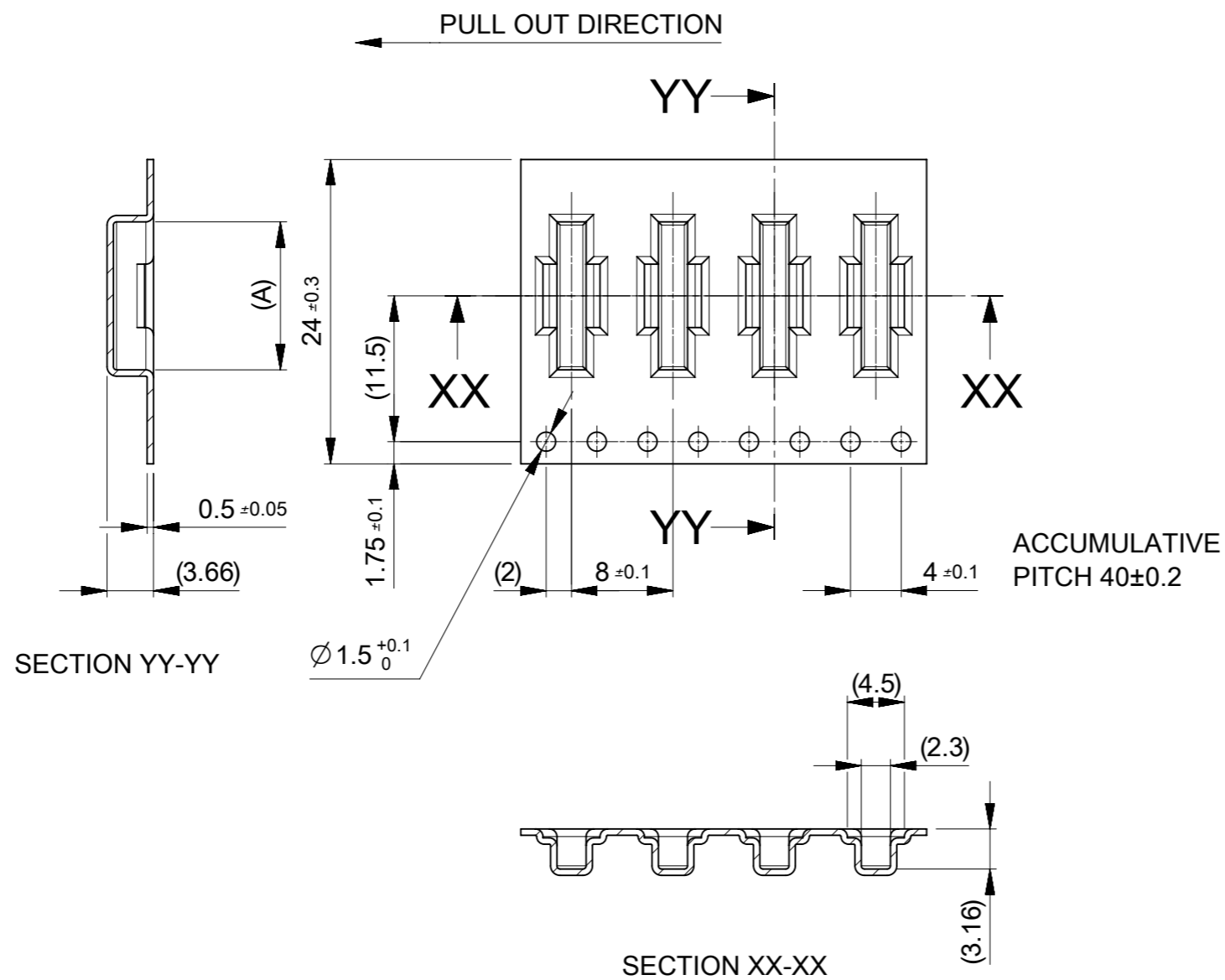

24	29.4	25.4	13.67	2039550601	---	---	60
			11.67	2039550501	---	---	50
			9.67	2039550401	---	---	40
キャリアテープ幅 CARRIER TAPE 幅 WIDTH	C	B	(A)	MATERIAL No.	HIGH VOL. TOOL	LOW VOL. TOOL	CIRCUIT
					SAMPLE PREPARATION		

THIS DRAWING CONTAINS INFORMATION THAT IS PROPRIETARY TO MOLEX ELECTRONIC TECHNOLOGIES, LLC AND SHOULD NOT BE USED WITHOUT WRITTEN PERMISSION

DIMENSION UNITS mm	SCALE 2:1	CURRENT REV DESC:		molex		
GENERAL TOLERANCES (UNLESS SPECIFIED)		EC NO: 600824				
ANGULAR TOL ± °		DRWN: STERUKI 2018/06/26		PRODUCT CUSTOMER DRAWING		
4 PLACES ±		CHK'D: KSASAKI 2018/06/29		DOCUMENT NUMBER		
3 PLACES ±		APPR: TKUSUHARA01 2018/06/29		2039550000		
2 PLACES ±		INITIAL REVISION:		DOC TYPE	DOC PART	REVISION
1 PLACE ±		DRWN: STERUKI 2018/04/27		PSD	001	A1
0 PLACES ±		APPR: TKUSUHARA01 2018/06/22		SHEET NUMBER		
DRAFT WHERE APPLICABLE MUST REMAIN WITHIN DIMENSIONS	THIRD ANGLE PROJECTION	DRAWING	SERIES	MATERIAL NUMBER	CUSTOMER	
		A3-SIZE	203955	SEE CHART		3 OF 3

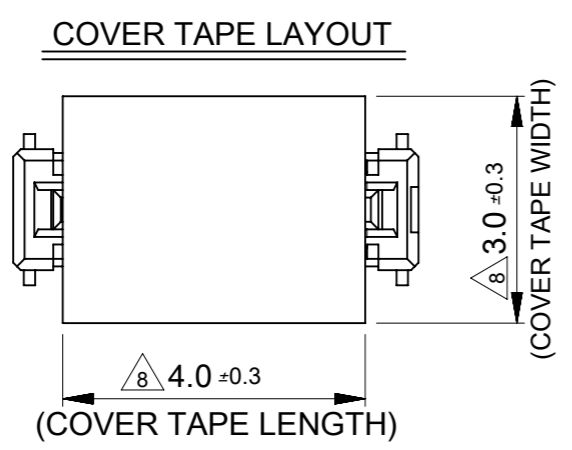
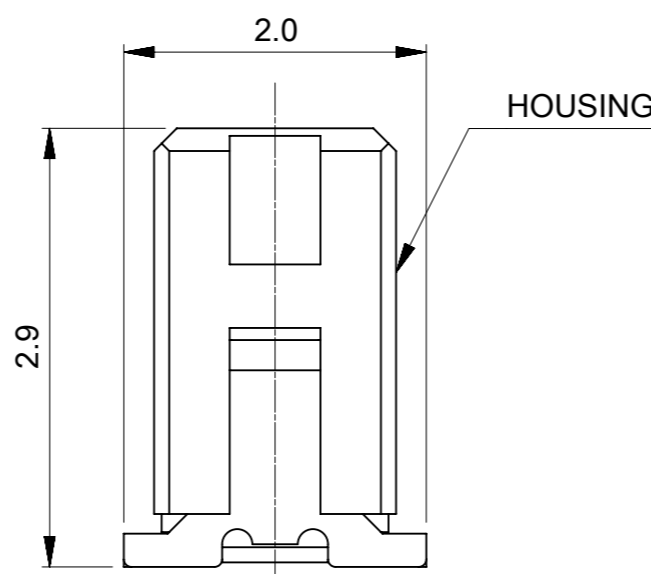
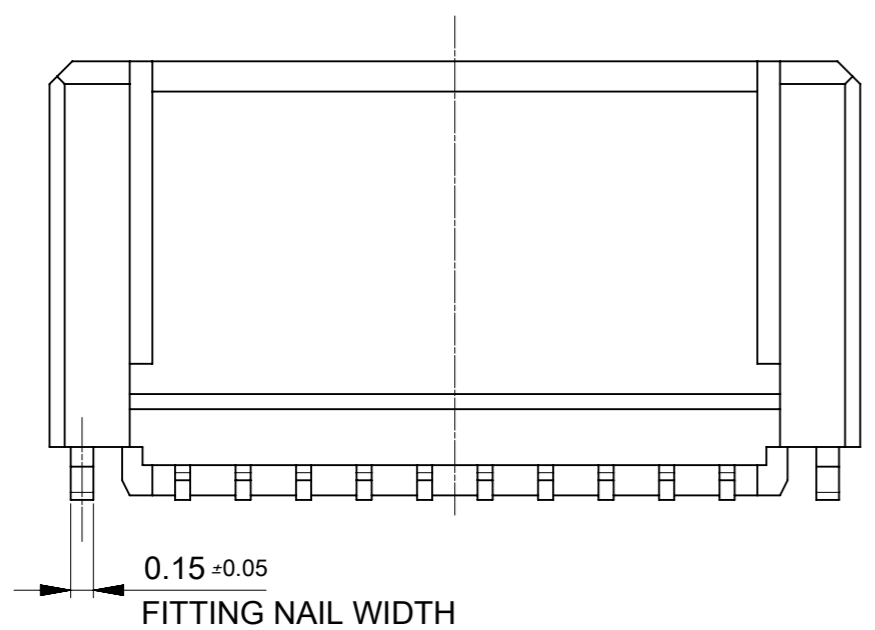
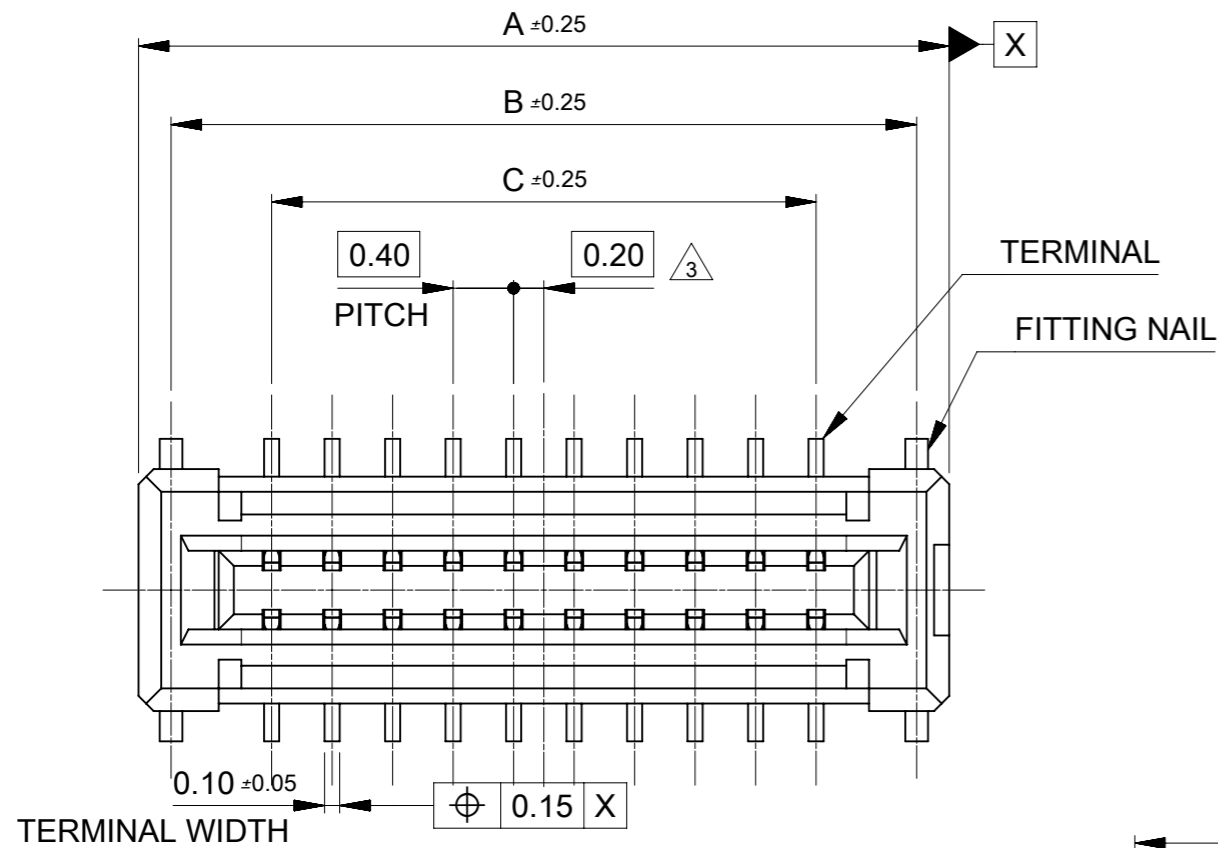

- 1 MATERIAL
 WAFER: LIQUID CRYSTAL POLYMER UL94V-0 (COLOR : BLACK)
 TERMINAL: COPPER ALLOY
 FITTING NAIL: COPPER ALLOY
 COVER TAPE: POLYIMIDE
- 2 PLATING
 TERMINAL :
 CONTACT AREA: GOLD PLATING.
 SOLDER TAIL AREA: GOLD PLATING.
 UNDERPLATE: NICKEL OVERALL.
 FITTING NAIL:
 SURFACE: TIN OVERALL
 UNDERPLATE: NICKEL OVERALL.
- $\triangle 3$ APPLY FOR (CIRCUIT/2)=EVEN.
- 4 MATE WITH :203956****
- 5 TAIL COPLANARITY TO BE 0.1 MAXIMUM.
- 6 ELV and RoHS COMPLIANT.
- $\triangle 7$ STACK HEIGHT IS KEPT FIXDLY BY A SPACER.
- $\triangle 8$ ALL CIRCUIT IS COMMON LENGTH.

11.6	12.93	13.36	2039550601	○	---	60
9.6	10.93	11.36	2039550501	○	---	50
7.6	8.93	9.36	2039550401	○	---	40
5.6	6.93	7.36	2039550301	○	\triangle	30
3.6	4.93	5.36	2039550201	○	---	20
C	B	A	EMBOSSSED TAPE PACKAGE	HIGH VOL. TOOL	LOW VOL. TOOL	CIRCUIT
			ORDER NO.	SAMPLE PREPARATION ○ : TOOLED \triangle : WORK IN PROCESS ---: TOOLING TO BE CONFIRMED		

CONNECTOR SERIES NO. : 2039551**1

THIS DRAWING CONTAINS INFORMATION THAT IS PROPRIETARY TO MOLEX ELECTRONIC TECHNOLOGIES, LLC AND SHOULD NOT BE USED WITHOUT WRITTEN PERMISSION

CURRENT REV DESC: RELEASED

molex

0.4 FLOATING BB CONN. H=5 REC ASSY

PRODUCT CUSTOMER DRAWING

DOCUMENT NUMBER: 2039551000 | DOC TYPE: PSD | DOC PART: 000 | REVISION: A3

DRAFT WHERE APPLICABLE MUST REMAIN WITHIN DIMENSIONS | THIRD ANGLE PROJECTION | DRAWING: A3-SIZE | SERIES: 203955 | MATERIAL NUMBER: SEE CHART | CUSTOMER: GENERAL | SHEET NUMBER: 1 OF 2

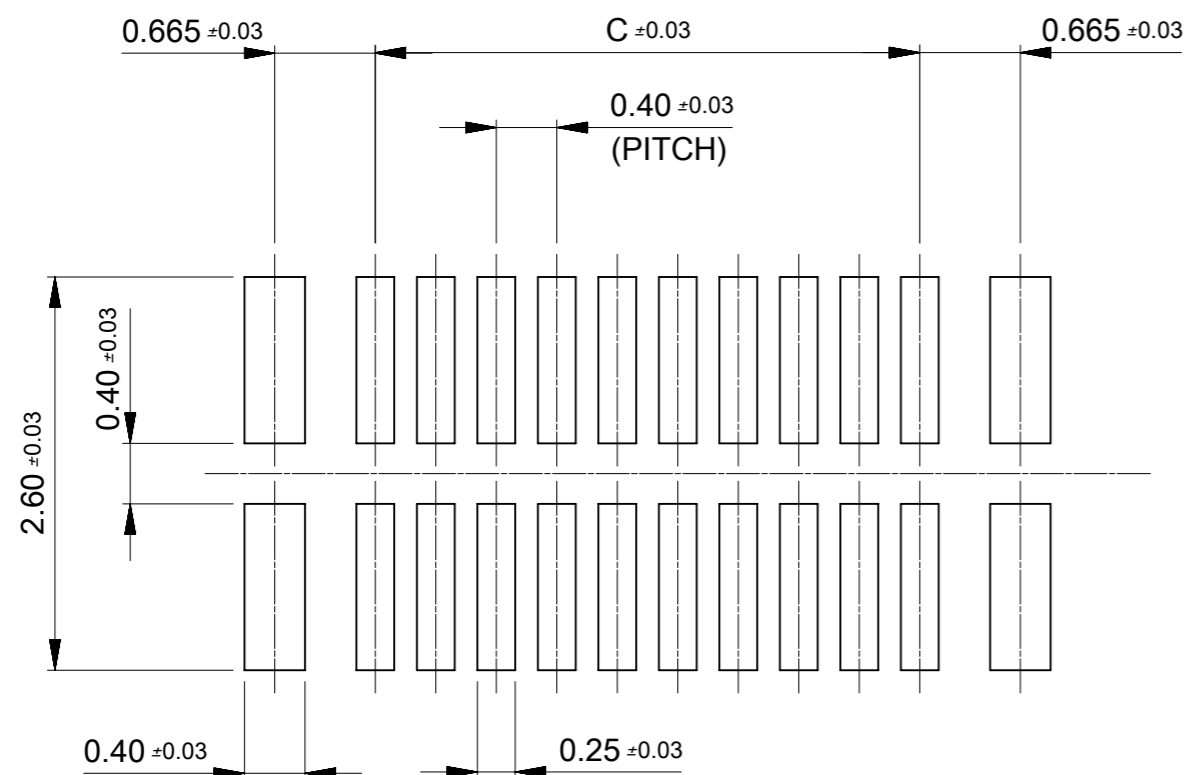

RECOMMENDED P.W.BOARD PATTERN LAYOUT(REFERENCE)

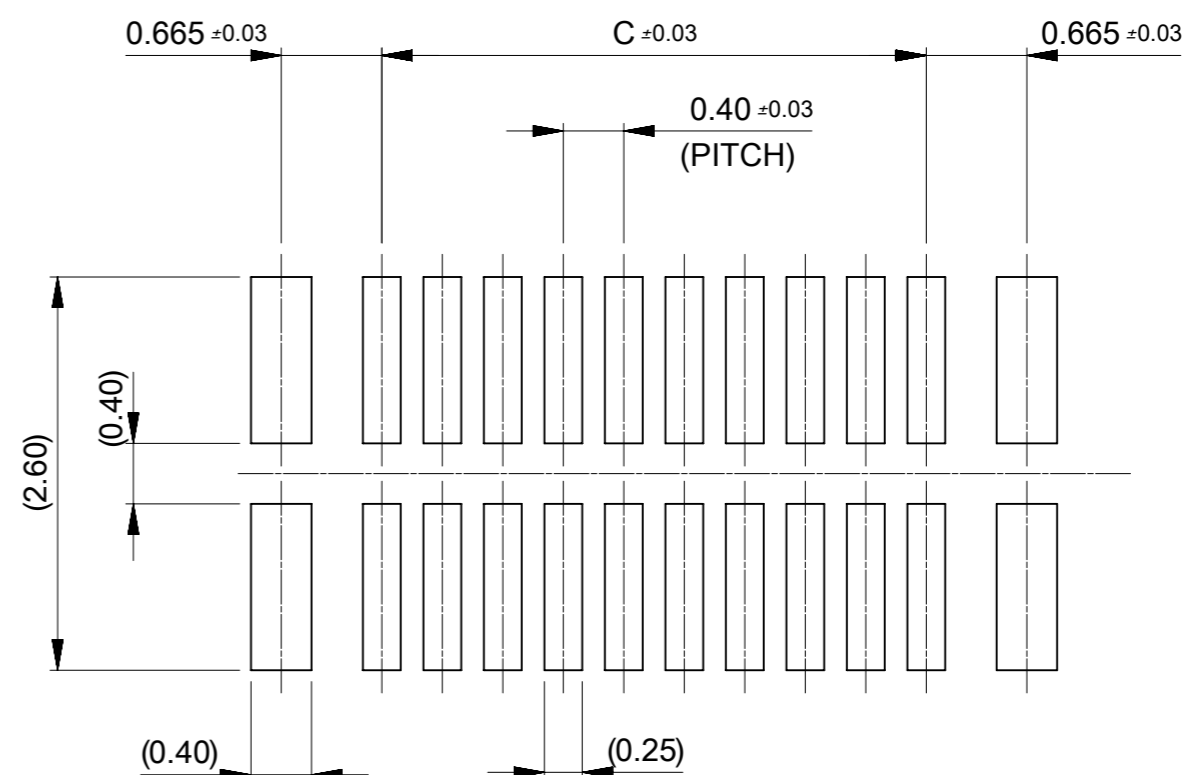

RECOMMENDED METAL MASK LAYOUT(REFERENCE)

RECOMMENDED THICKNESS OF METAL MASK : t=0.1mm
 RECOMMENDED OPEN APERTURE RATIO OF METAL MASK : 100%

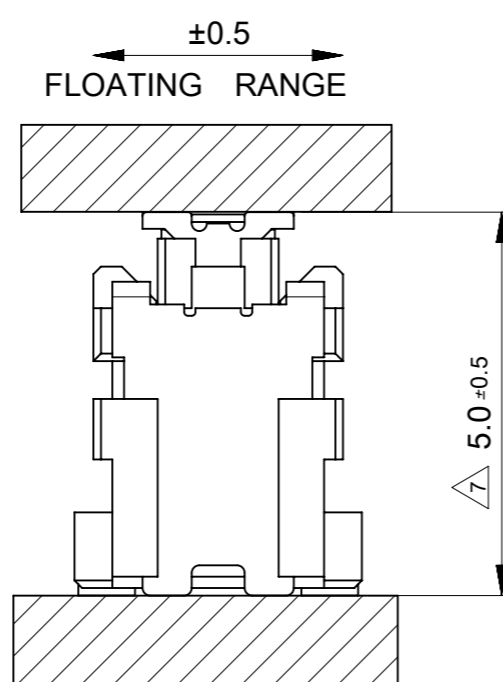
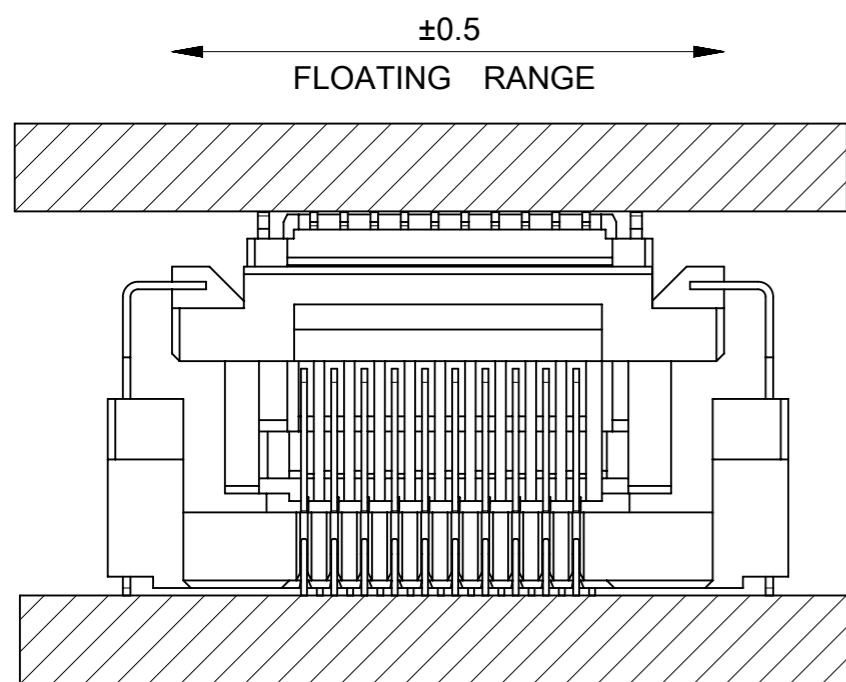

THIS DRAWING CONTAINS INFORMATION THAT IS PROPRIETARY TO MOLEX ELECTRONIC TECHNOLOGIES, LLC AND SHOULD NOT BE USED WITHOUT WRITTEN PERMISSION									
DIMENSION UNITS		SCALE		CURRENT REV DESC: RELEASED				molex	
mm		20:1							
GENERAL TOLERANCES (UNLESS SPECIFIED)				EC NO: 613911				0.4 FLOATING BB CONN. H=5 REC ASSY	
ANGULAR TOL ± 1.0 °				DRWN: STERUKI 2019/03/18					
4 PLACES ± 0.2				CHK'D: KSASAKI 2019/03/18					
3 PLACES ± 0.2				APPR: TKUSUHARA01 2019/03/18				PRODUCT CUSTOMER DRAWING	
2 PLACES ± 0.2				INITIAL REVISION:				DOCUMENT NUMBER	
1 PLACE ± 0.2				DRWN: STERUKI 2018/06/14				2039551000	
0 PLACES ± 0.2				APPR: TKUSUHARA01 2018/06/22				DOC TYPE DOC PART REVISION	
DRAFT WHERE APPLICABLE MUST REMAIN WITHIN DIMENSIONS				THIRD ANGLE PROJECTION		DRAWING		SHEET NUMBER	
				A3-SIZE		SERIES		2 OF 2	
				203955		MATERIAL NUMBER		CUSTOMER	
				SEE CHART		GENERAL			