

Surface Mount Specialty Polymer Solid Aluminum Electrolytic Capacitors

NSP Series

FEATURES

- NEW "X", "Y", "Z", "U" & "V" TYPE HIGH RIPPLE CURRENT/VERY LOW ESR
- REPLACES MULTIPLE TANTALUM CHIPS IN HIGH CURRENT POWER SUPPLIES AND VOLTAGE REGULATORS
- FITS EIA (7343) "D" AND "E" TANTALUM CHIP LAND PATTERNS
- Pb-FREE AND COMPATIBLE WITH REFLOW SOLDERING

**EXTENDED LOAD LIFE
HIGH RIPPLE CURRENT
ULTRA LOW ESR**

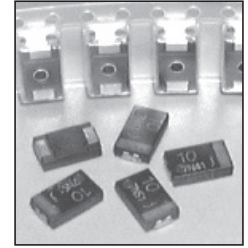

CHARACTERISTICS (Note 1)

Rated Working Range	2.0 ~ 6.3VDC	LOW ESR COMPONENT SOLID POLYMER ELECTROLYTE For Performance Data see www.LowESR.com	
Rated Capacitance Range	68 ~ 560 μ F		
Operating Temperature Range	-55 ~ +105°C		
Capacitance Tolerance	\pm 20% (M)		
Max. Leakage Current (μ A) After 2 Minutes (+20°C)	All Case Sizes	See Standard Products and Specifications Tables	
Max. Tan δ , 120Hz, +20°C			
High Temperature Load Life 2,000 Hours @ 105°C at Rated Working Voltage	Capacitance Change	Within \pm 20% of initial measured value	
	Tan δ	Less than 200% specified max. value	
	Leakage Current	Less than 300% specified max. value	
Damp Heat Test 500 Hours @ +60°C at 90% RH	Capacitance Change	6.3V	Within -20%/+50% of initial measured value
		4V	Within -20%/+60% of initial measured value
		2V, 2.5V	Within -20%/+70% of initial measured value
	Tan δ	Less than 200% of specified max. value	
	Leakage Current	Less than specified max. value	

Note 1: Specifications that apply to "Not Recommended" parts begin on page 5.

STANDARD PRODUCTS AND SPECIFICATIONS

NIC Part Number	WV (Vdc)	Cap. (μ F)	Max. LC (μ A)	Tan δ	Max. Ripple Current +45°C & 100KHz (mArms)	Max. ESR +20°C & 100KHz (Ω)	Height H	
NSP181M2D6ZATRF	2.0	180	36.0	0.06	6,300	0.009	1.9 \pm 0.1	
NSP221M2D6ATRF		220	44.0	0.06	5,100	0.015	1.9 \pm 0.1	
NSP221M2D6ZATRF		220	44.0	0.06	6,300	0.009	1.9 \pm 0.1	
NSP221M2DYATRF		220	44.0	0.06	7500	0.006	1.0 max.	
NSP221M2DUATRF		220	44.0	0.06	8500	0.0045	1.0 max.	
NSP221M2D5YATRF		220	44.0	0.06	7500	0.006	1.1 \pm 0.1	
NSP271M2D6XATRF		270	54.0	0.06	5,600	0.012	1.9 \pm 0.1	
NSP271M2D6ZATRF		270	54.0	0.06	6,300	0.009	1.9 \pm 0.1	
NSP271M2D6YATRF		270	54.0	0.06	7,500	0.006	1.9 \pm 0.1	
NSP271M2D6UATRF		270	54.0	0.06	8,500	0.0045	1.9 \pm 0.1	
NSP331M2D6ATRF		330	66.0	0.06	5,100	0.015	1.9 \pm 0.1	
NSP331M2D6XATRF		330	66.0	0.06	5,600	0.012	1.9 \pm 0.1	
NSP331M2D6ZATRF		330	66.0	0.06	6,300	0.009	1.9 \pm 0.1	
NSP331M2D1YATRF		330	66.0	0.06	7,500	0.006	1.4 \pm 0.1	
NSP331M2D6YATRF		330	66.0	0.06	7,500	0.006	1.9 \pm 0.1	
NSP331M2D6UATRF		330	66.0	0.06	8,500	0.0045	1.9 \pm 0.1	
NSP331M2D6VATRF		330	66.0	0.06	10,200	0.003	1.9 \pm 0.1	
NSP391M2D6ATRF		390	78.0	0.06	5,100	0.015	1.9 \pm 0.1	
NSP391M2D6ZATRF		390	78.0	0.06	6,300	0.009	1.9 \pm 0.1	
NSP391M2D6YATRF		390	78.0	0.06	7,500	0.006	1.9 \pm 0.1	
NSP391M2D6UATRF		390	78.0	0.06	8,500	0.0045	1.9 \pm 0.1	
NSP471M2D6ATRF		470	94.0	0.06	5,100	0.015	1.9 \pm 0.1	
NSP471M2D6ZATRF		470	94.0	0.06	6,300	0.009	1.9 \pm 0.1	
NSP471M2D6YATRF		470	94.0	0.06	7,500	0.006	1.9 \pm 0.1	
NSP471M2D6UATRF		470	94.0	0.06	8,500	0.0045	1.9 \pm 0.1	
NSP471M2D6VATRF		470	94.0	0.06	10,200	0.003	1.9 \pm 0.1	
NSP561M2D6ATRF		560	112.0	0.06	5,100	0.015	1.9 \pm 0.1	
NSP561M2D6UATRF		560	112.0	0.06	8,500	0.0045	1.9 \pm 0.1	
NSP561M2D6VATRF		560	112.0	0.06	10,200	0.003	1.9 \pm 0.1	
NSP151M2.5D6ZATRF		2.5	150	37.5	0.06	6,300	0.009	1.9 \pm 0.1
NSP181M2.5D6ZATRF			180	45.0	0.06	6,300	0.009	1.9 \pm 0.1
NSP181M2.5DYATRF			180	45.0	0.06	7500	0.006	1.0 max.
NSP181M2.5DUATRF			180	45.0	0.06	8500	0.0045	1.0 max.
NSP181M2.5D5YATRF	180		45.0	0.06	7500	0.006	1.1 \pm 0.1	

Surface Mount Specialty Polymer Solid Aluminum Electrolytic Capacitors

NSP Series

STANDARD PRODUCTS AND SPECIFICATIONS

NIC Part Number	WV	Cap.	Max. LC	Tan δ	Max. Ripple Current +45°C & 100KHz (mArms)	Max. ESR +20°C & 100KHz (Ω)	Height H	
	(Vdc)	(μ F)	(μ A)					
NSP221M2.5D6ATRF	2.5	220	55.0	0.06	5,100	0.015	1.9±0.1	
NSP221M2.5D6ZATRF		220	55.0	0.06	6,300	0.009	1.9±0.1	
NSP221M2.5D6YATRF		220	55.0	0.06	7,000	0.007	1.9±0.1	
NSP271M2.5D6YATRF		270	67.5	0.06	7,000	0.007	1.9±0.1	
NSP271M2.5D1YATRF		270	67.5	0.06	7,500	0.006	1.4±0.1	
NSP331M2.5D6ATRF		330	82.5	0.06	5,100	0.015	1.9±0.1	
NSP331M2.5D6ZATRF		330	82.5	0.06	6,300	0.009	1.9±0.1	
NSP331M2.5D6YATRF		330	82.5	0.06	7,500	0.006	1.9±0.1	
NSP331M2.5D6UATRF		330	82.5	0.06	8,500	0.0045	1.9±0.1	
NSP391M2.5D6ATRF		390	97.5	0.06	5,100	0.015	1.9±0.1	
NSP391M2.5D6ZATRF		390	97.5	0.06	6,300	0.009	1.9±0.1	
NSP391M2.5D6YATRF		390	97.5	0.06	7,500	0.006	1.9±0.1	
NSP391M2.5D6UATRF		390	97.5	0.06	8,500	0.0045	1.9±0.1	
NSP471M2.5D6ATRF		470	117.5	0.06	5,100	0.015	1.9±0.1	
NSP471M2.5D6ZATRF		470	117.5	0.06	6,300	0.009	1.9±0.1	
NSP471M2.5D6YATRF		470	117.5	0.06	7,500	0.006	1.9±0.1	
NSP471M2.5D6UATRF		470	117.5	0.06	8,500	0.0045	1.9±0.1	
NSP471M2.5D6VATRF		470	117.5	0.06	10,200	0.003	1.9±0.1	
NSP820M4D6ZATRF		4.0	82	32.8	0.06	6,300	0.009	1.9±0.1
NSP101M4D6ZATRF			100	40.0	0.06	6,300	0.009	1.9±0.1
NSP121M4D5ATRF	120		48.0	0.06	5,100	0.015	1.1±0.1	
NSP121M4DZATRF	120		48.0	0.06	6,300	0.009	1.0 max.	
NSP151M4D6ATRF	150		60.0	0.06	5,100	0.015	1.9±0.1	
NSP151M4D6ZATRF	150		60.0	0.06	6,300	0.009	1.9±0.1	
NSP151M4D6YATRF	150		60.0	0.06	7,000	0.007	1.9±0.1	
NSP181M4D1ATRF	180		72.0	0.06	5,100	0.015	1.4±0.1	
NSP181M4D6ATRF	180		72.0	0.06	5,100	0.015	1.9±0.1	
NSP181M4D6XATRF	180		72.0	0.06	5,600	0.012	1.9±0.1	
NSP181M4D6ZATRF	180		72.0	0.06	6,300	0.009	1.9±0.1	
NSP221M4D6ATRF	220		88.0	0.06	5,100	0.015	1.9±0.1	
NSP221M4D6XATRF	220		88.0	0.06	5,600	0.012	1.9±0.1	
NSP221M4D6ZATRF	220		88.0	0.06	6,300	0.009	1.9±0.1	
NSP271M4D6ATRF	270		108.0	0.06	5,100	0.015	1.9±0.1	
NSP271M4D6ZATRF	270		108.0	0.06	6,300	0.009	1.9±0.1	
NSP331M4D6ATRF	330		132.0	0.06	5,100	0.015	1.9±0.1	
NSP680M6.3D5ATRF	6.3		68	42.8	0.06	5,100	0.015	1.1±0.1
NSP680M6.3DZATRF			68	42.8	0.06	6,300	0.009	1.0 max.
NSP101M6.3D1ATRF			100	63.0	0.06	5,100	0.015	1.4±0.1
NSP101M6.3D6ATRF		100	63.0	0.06	5,100	0.015	1.9±0.1	
NSP121M6.3D6ATRF		120	75.6	0.06	5,100	0.015	1.9±0.1	
NSP121M6.3D6ZATRF		120	75.6	0.06	7,000	0.007	1.9±0.1	
NSP151M6.3D6ATRF		150	94.5	0.06	5,100	0.015	1.9±0.1	
NSP151M6.3D6XATRF		150	94.5	0.06	5,600	0.012	1.9±0.1	
NSP151M6.3D6ZATRF		150	94.5	0.06	6,300	0.009	1.9±0.1	
NSP181M6.3D6ATRF		180	113.4	0.06	5,100	0.015	1.9±0.1	
NSP181M6.3D6ZATRF		180	113.4	0.06	6,300	0.009	1.9±0.1	
NSP221M6.3D6ATRF		220	138.0	0.06	5,100	0.015	1.9±0.1	

RIPPLE CURRENT TEMPERATURE CORRECTION FACTORS

Case Code	≤ +45°C	>+45°C ~ ≤+85°C	>+85°C ~ +105°C
All	1.0	0.7	0.25

PART NUMBERING SYSTEM

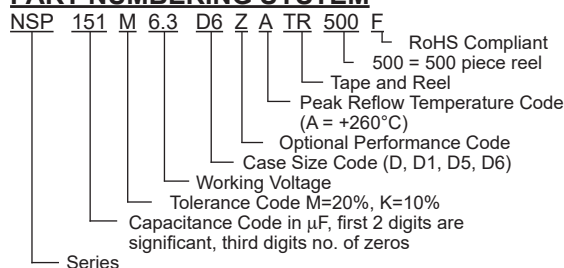

Surface Mount Specialty Polymer Solid Aluminum Electrolytic Capacitors

NSP Series

RECOMMENDED 260°C REFLOW SOLDERING PROFILE

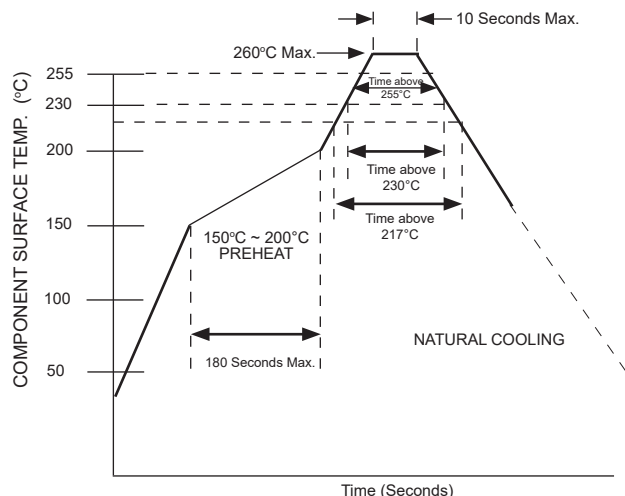

Item	Maximum Duration
Peak Temperature +260°C	10 seconds max.
Time above +255°C	30 seconds max.
Time above +230°C	130 seconds max.
Time above +217°C	150 seconds max.

Notes: Compliant to IPC/J-STD-020D standard

1. SAC alloy (+217°C) reflow soldering compatible
2. Soldering heat limits apply to the top surface of component
3. If you have concerns about your reflow soldering profile review them with NIC to insure compatible [tpmg@niccomp.com]
4. Three reflow passes are allowed (cooling down period to room temperature between each pass).

Storage Conditions:

Temperature: +5°C ~ +30°C

Humidity: <60% RH

Packaging: Moisture barrier bag

Storage Time: Parts should be soldered within 2 years of the production date and/or within 7 days of opening the moisture barrier bag.

RECOMMENDED LAND PATTERNS (mm)

Case Code	A	B	C
D, D1, D5, D6	2.8	4.0	8.8

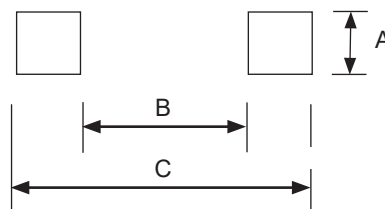

Please note the NSP series will fit on standard "D" and "E" size (7343) tantalum chip capacitor land patterns

DIMENSIONS (mm)

Case Code	L ±0.2	W ±0.2	H	W1 ±0.1	S ±0.3
D, D1, D5, D6	7.3	4.3	see values table	2.4	1.3

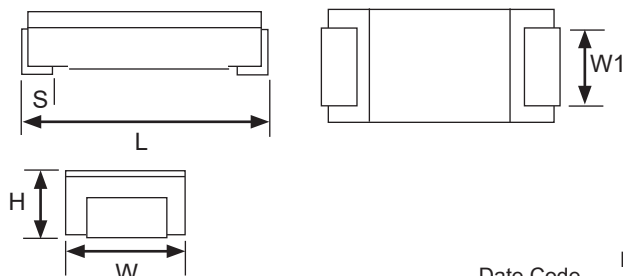

VOLTAGE CODES

Voltage	Code
2.0Vdc	d
2.5Vdc	e
4.0Vdc	g
6.3Vdc	j

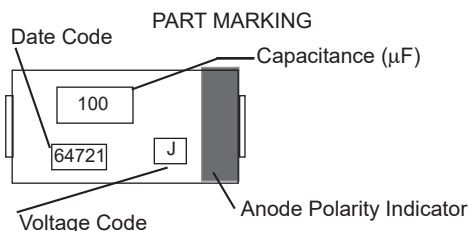

PRECAUTIONS

Please review the notes on correct use, safety and precautions found at <https://www.niccomp.com/resource/files/aluminum/AlumApplInfoCautions.pdf>
If in doubt or uncertainty, please review your specific application - process details with NIC's technical support personnel: tpmg@niccomp.com



NIC COMPONENTS CORP.

www.niccomp.com

SPECIFICATIONS ARE SUBJECT TO CHANGE

Surface Mount Specialty Polymer Solid Aluminum Electrolytic Capacitors

NSP Series

CARRIER TAPE DIMENSIONS (mm)

Case Code	A±0.2	B±0.2	Dφ	E±0.1	F±0.1	P ₀ ±0.1	P ₁ ±0.1	t±0.2		W±0.3
								D, D5	D1, D6	
D, D1, D5, D6	7.6	4.5	1.5 ^{+0.1}	5.50	1.75	4.0	8.0	1.5	2.4	12.0

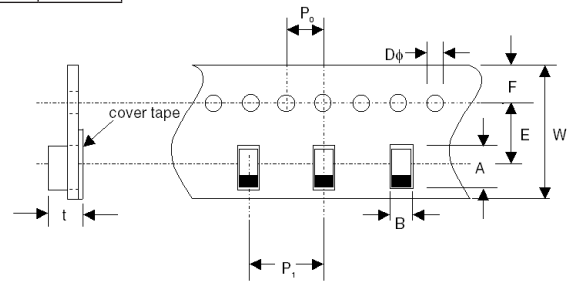

REEL DIMENSIONS (mm)

A±2.0	B±1.0	C±0.5	D±0.8	E±0.5	T±1.0	t	W±1.0
330	80	13.0	21.0	2.0	20.0	3.0	14

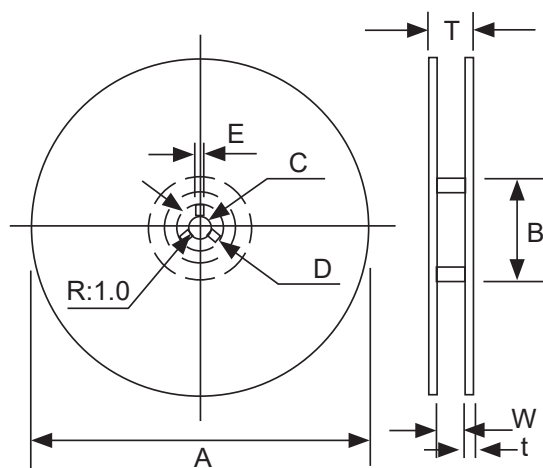

Case Code	Reel Quantity
D, D1, D5, D6	3,500