

molex[®] APPLICATION SPECIFICATION

1.0 SCOPE

This specification covers the requirements for the application of Ultra-Fit 3.50 mm pitch wire to board connector systems.

2.0 PRODUCT NAME AND SERIES NUMBERS

Ultra-Fit Female Crimp Terminal	172253
Ultra-Fit Receptacle Housing	172256 / 172258
TPA	172264
Ultra-Fit Vertical Header	172286 / 172287 / 172298 / 172299
Mega-Fit Right Angle Header	172310 / 172316

3.0 REFERENCE DOCUMENTS

See the appropriate sales drawings for information on specific part numbers and materials.

4.0 GENERAL APPLICATION NOTES

Appearance:

- Parts conform to class "B" requirements of cosmetic specification PS-45499-002 except where noted on the sales drawings.

Connector Application

- This connector system is designed to mate gold plating to gold plating OR tin plating to tin plating. Never cross mate tin plated parts to gold plated parts.
- This connector system is not designed for current sharing (i.e. splitting one current load across multiple circuits)
- Connectors are not to be mated or unmated while circuits are live except per the current interrupt rating listed in product specification: PS-172323-0001

Packaging

- The parts should remain in the original Molex packaging until ready for use to prevent damage.

Chemical Exposure

- Do not store terminals or header assemblies near any chemicals listed below as they may cause corrosion in the terminal contacts.

Alkalies	Ammonia	Citrates	Phosphates	Citrates	Sulfur Compounds
Amines	Carbonates	Nitrites	Sulfur Nitrites		Tartrates

REVISION: 3	ECR/ECN INFORMATION: EC No: UCP2015-2467 DATE: 2015/8/1	TITLE: APPLICATION SPECIFICATION FOR ULTRA-FIT WIRE TO BOARD CONNECTOR SYSTEM	SHEET No. 1 of 8
DOCUMENT NUMBER: AS-172323-0001	CREATED / REVISED BY: D. ROSCA	CHECKED BY: R. HODGE	APPROVED BY: R. HODGE

molex[®] APPLICATION SPECIFICATION

Crimped Terminal Extraction

- Female terminal extraction tool: See Molex part# 011-03-0016 instructions online on website. Do not reuse terminals that have been removed with the extraction tool. The receptacle housing can be reused if it was not damaged.

Minimum wire bend, cable tie or twist location

Circuit Sizes	Dim T Min. (single row)	Dim T Min. (dual row)
2	.50" (12.7 mm)	
4-6	.75" (19.1 mm)	.75" (19.1 mm)
8	1.00" (25.4 mm)	
10-12		1.25" (31.75 mm)
14-16		1.25" (31.75 mm)

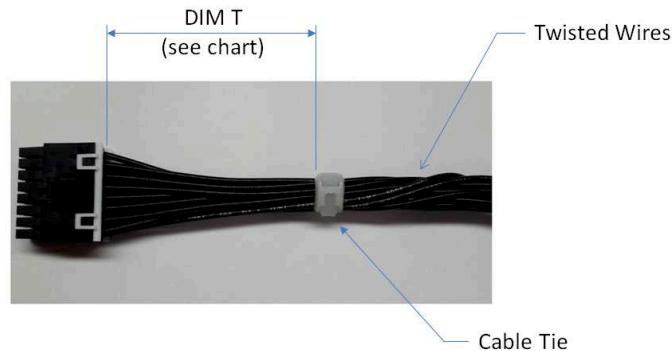

- The "T" dimension defines a "free" length of wire, or a length of wire that is not subject to significant bias by external factors such as a wire tie, wire twisting, or other means of bending or deforming of the wires that repositions them from their natural relaxed state or location where they enter the housing. This dimension is a general recommendation and may need to be adjusted for different wire gauges and wire type and insulation thickness and insulation material.
- Wires are to be dressed in such a manner to allow the terminals to float freely in the receptacle pocket.

Connector Testing

- Do not use Ultra-Fit connectors as test parts, they are not intended to be used with repeated mating. Follow durability cycles as listed in PS-172323-0001

REVISION: 3	ECR/ECN INFORMATION: EC No: UCP2015-2467 DATE: 2015/8/1	TITLE: APPLICATION SPECIFICATION FOR ULTRA-FIT WIRE TO BOARD CONNECTOR SYSTEM	SHEET No. 2 of 8
DOCUMENT NUMBER: AS-172323-0001	CREATED / REVISED BY: D. ROSCA	CHECKED BY: R. HODGE	APPROVED BY: R. HODGE

molex[®] APPLICATION SPECIFICATION

Crimped Terminal Insertion

- Terminals are inserted in opposite orientation to each other for top and bottom row. They should be inserted with the lock tab oriented facing one to each other on both rows.
- DO NOT reuse receptacle housing if a crimped terminal was pushed out without an extraction tool.

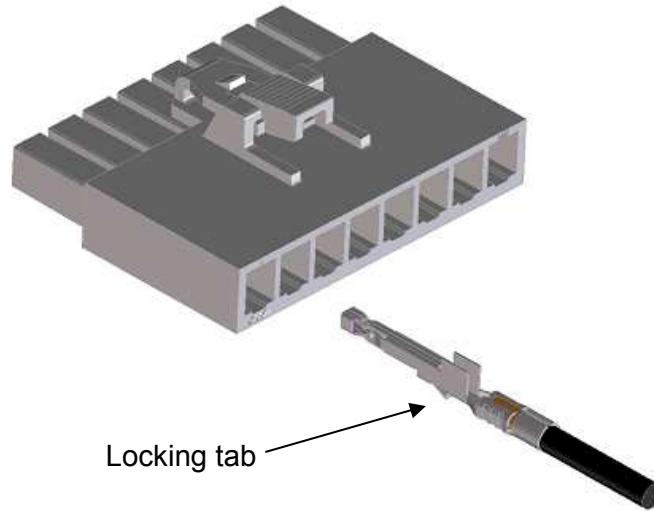

Single Row Receptacle – Terminal position into the housing

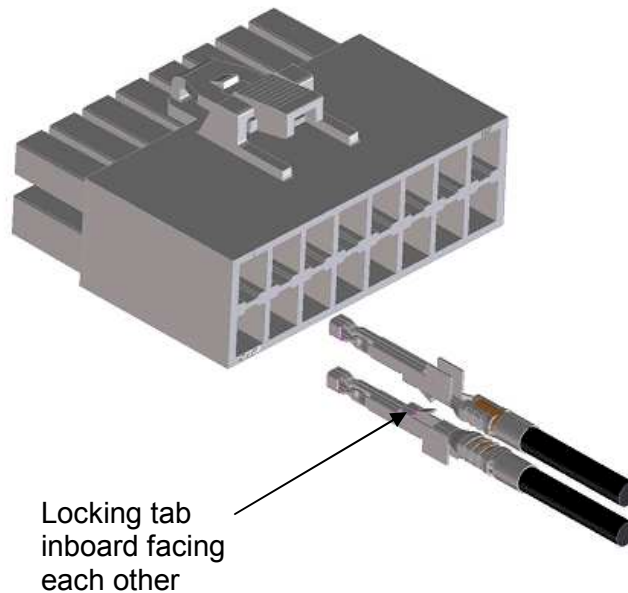

Dual Row Receptacle – Terminal position into the housing

REVISION: 3	ECR/ECN INFORMATION: EC No: UCP2015-2467 DATE: 2015/8/1	TITLE: APPLICATION SPECIFICATION FOR ULTRA-FIT WIRE TO BOARD CONNECTOR SYSTEM	SHEET No. 3 of 8
DOCUMENT NUMBER: AS-172323-0001	CREATED / REVISED BY: D. ROSCA	CHECKED BY: R. HODGE	APPROVED BY: R. HODGE

molex[®] APPLICATION SPECIFICATION

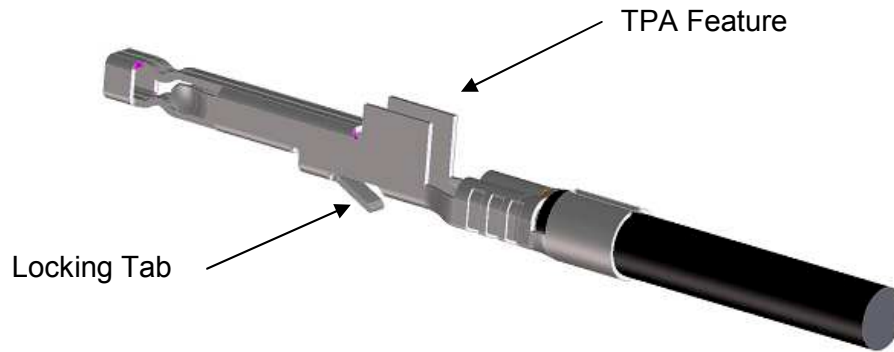

- Ensure terminals are fully seated and locked during terminal insertion to the receptacle housing

TPA Assembly over the wires

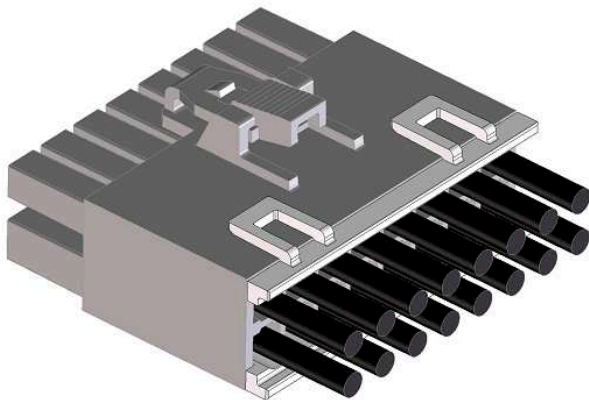

REVISION: 3	ECR/ECN INFORMATION: EC No: UCP2015-2467 DATE: 2015/8/1	TITLE: APPLICATION SPECIFICATION FOR ULTRA-FIT WIRE TO BOARD CONNECTOR SYSTEM	SHEET No. 4 of 8
DOCUMENT NUMBER: AS-172323-0001	CREATED / REVISED BY: D. ROSCA	CHECKED BY: R. HODGE	APPROVED BY: R. HODGE

molex[®] APPLICATION SPECIFICATION

Crimp Terminal Appearance

- Forming marks on female terminal are normal. These are due to stretching of the plating during the forming process and are superficial cracks on the plating surface.

Forming Marks

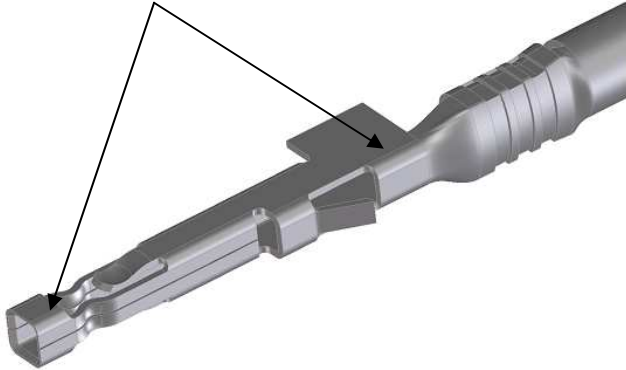

Crimp Terminal Function

- DO NOT use terminals with damaged locking tabs or front face:



Normal Locking Tab



Collapsed Locking Tab

REVISION: 3	ECR/ECN INFORMATION: EC No: UCP2015-2467 DATE: 2015/8/1	TITLE: APPLICATION SPECIFICATION FOR ULTRA-FIT WIRE TO BOARD CONNECTOR SYSTEM	SHEET No. 5 of 8
DOCUMENT NUMBER: AS-172323-0001	CREATED / REVISED BY: D. ROSCA	CHECKED BY: R. HODGE	APPROVED BY: R. HODGE

molex[®] APPLICATION SPECIFICATION



Normal Square
Front Box



Damaged
Front Box

Crimp Terminal Handling

- Due to exposed terminal interface, keep crimp terminals on prepackaged reel until they are crimped onto wires. Do not pre-cut and bulk pack terminals due to risk of damaging the contact interface. Store and handle crimped terminals so the interface does not make contact with other terminals or foreign objects. If terminal interface is damaged please discard prior to assembly.

Crimping

- For acceptable crimp tools and specifications see application tooling section on Molex.com listed for each terminal part number.
- Use with multi strand wire only. Single strand wire should not be used.
- This female crimp terminal is designed for single wire crimping only, no double wire crimping is allowed.
- Use only Molex specified crimp tooling, refer to Molex.com for acceptable crimp tooling. Crimped terminals must also meet Molex crimp specifications. Using crimp tooling/specifications other than specified voids any product warranties and will negatively impact mechanical and electrical performance.

REVISION: 3	ECR/ECN INFORMATION: EC No: UCP2015-2467 DATE: 2015/8/1	TITLE: APPLICATION SPECIFICATION FOR ULTRA-FIT WIRE TO BOARD CONNECTOR SYSTEM	SHEET No. 6 of 8
DOCUMENT NUMBER: AS-172323-0001	CREATED / REVISED BY: D. ROSCA	CHECKED BY: R. HODGE	APPROVED BY: R. HODGE

molex[®] APPLICATION SPECIFICATION

Header Appearance

- Discoloration in the bandolier carrier area of the pin is inherent to the plating process and is due to the masking effect of the carrier. This discoloration is in a non-functional area of the pin and will not affect the performance of the header assembly. Refer to cosmetic specification PS-45499-002.

Right Angle Header Appearance

- Forming marks on header pins are acceptable. Refer to cosmetic specification PS-45499-002.

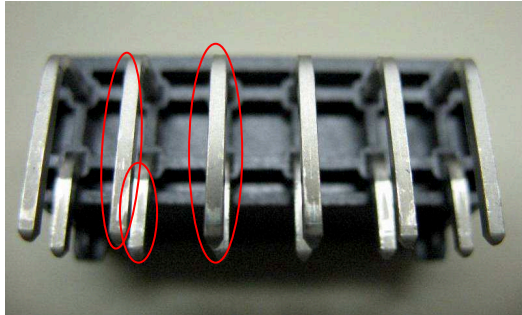

Header Assembly to Board

- Headers are designed with press fit pegs and need to be pushed into the circuit board.
- Header should be flush with board after insertion.
- See below for solder process information.



Solder Process Temperatures

- Wave Solder: 260°C Max
- Reflow Solder: 260°C Max

Reflow Soldering Profile

- See AS-40000-5013

Plated Thru Hole profile

REVISION: 3	ECR/ECN INFORMATION: EC No: UCP2015-2467 DATE: 2015/8/1	TITLE: APPLICATION SPECIFICATION FOR ULTRA-FIT WIRE TO BOARD CONNECTOR SYSTEM	SHEET No. 7 of 8
DOCUMENT NUMBER: AS-172323-0001	CREATED / REVISED BY: D. ROSCA	CHECKED BY: R. HODGE	APPROVED BY: R. HODGE

molex[®] APPLICATION SPECIFICATION

- Keep outer ring at 5 mils max with at least 20 mils distance between adjacent metal pads

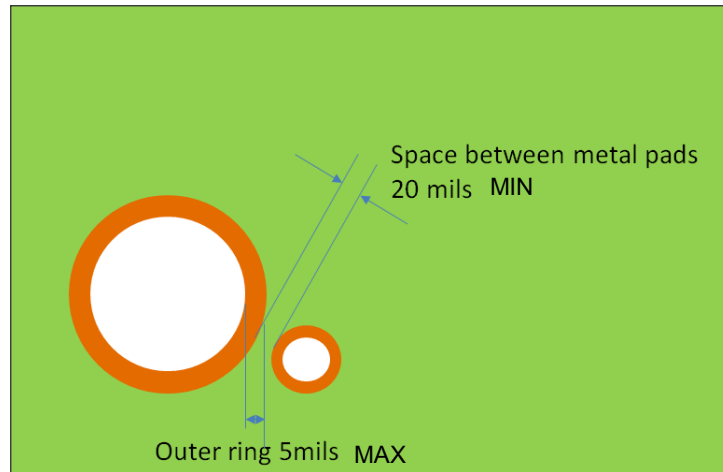

Wave Solder Direction

- Preferred wave solder direction:

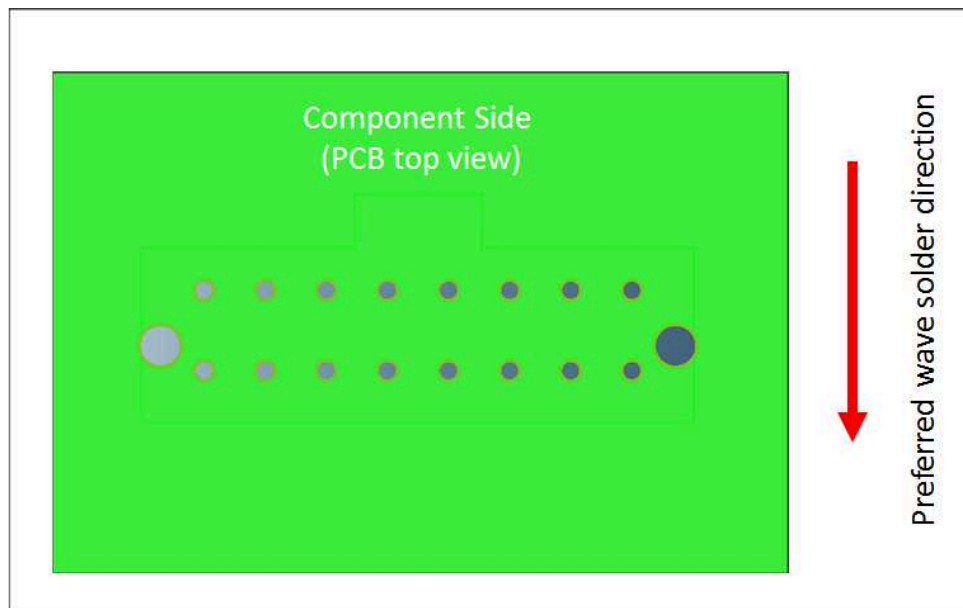

REVISION: 3	ECR/ECN INFORMATION: EC No: UCP2015-2467 DATE: 2015/8/1	TITLE: APPLICATION SPECIFICATION FOR ULTRA-FIT WIRE TO BOARD CONNECTOR SYSTEM	SHEET No. 8 of 8
DOCUMENT NUMBER: AS-172323-0001	CREATED / REVISED BY: D. ROSCA	CHECKED BY: R. HODGE	APPROVED BY: R. HODGE