

**APPLICATIONS:** EIA rack-mount chassis, data processing, video and telecommunication racks, electro/mechanical devices, and photographic equipment. Use model 305-ALR whenever recessed mounting and positive lock-out is required. **This product is covered by U.S. and various foreign patents issued and/or pending.**

Lock-Out With Front Disconnect  
Over-Travel, Medium Duty Slide  
Up to 140 lb. [64 kg.] Capacity\*\*

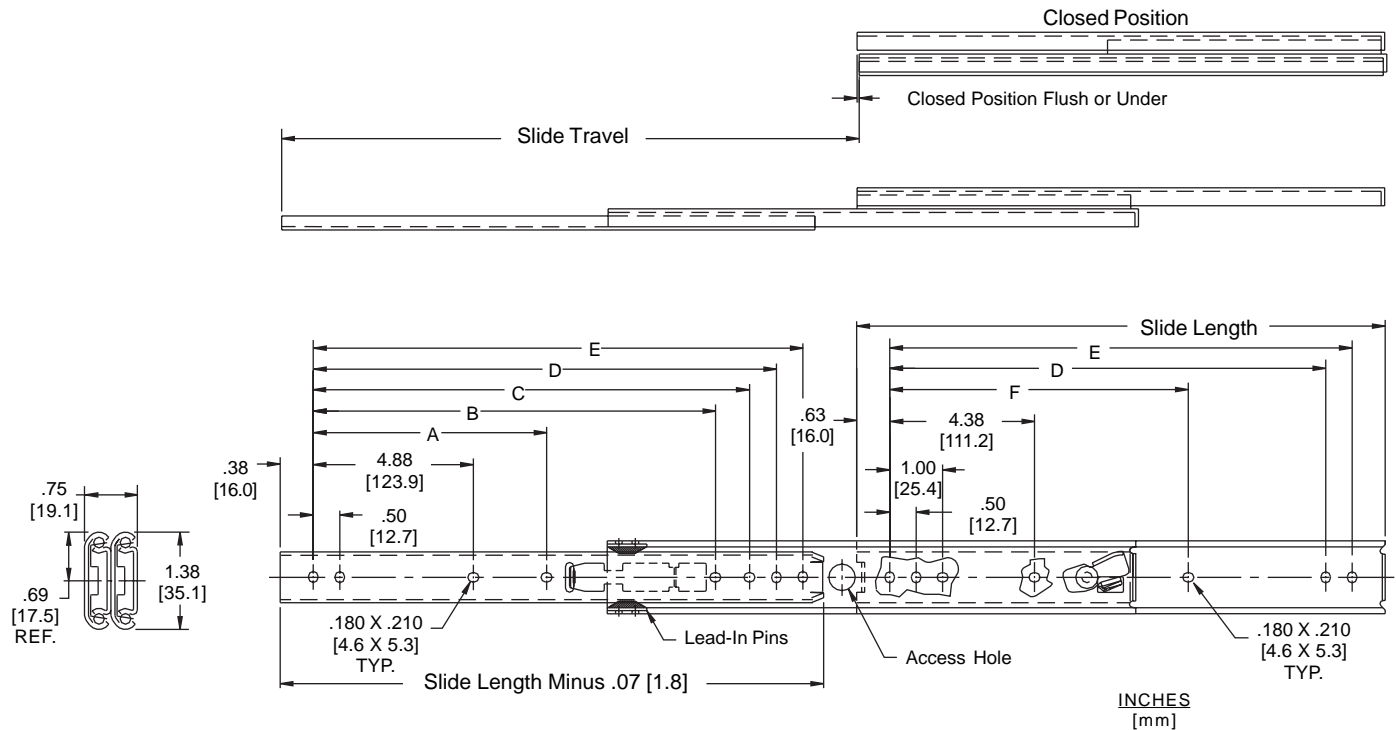

**Finish** Bright electro-zinc plating (C) or black zinc\* (CB) finish available

**Sidespace** .38" (moving member) +.030/-0.000  
[9.5mm (moving member) [+0.75/-0.00]

**Length** 12" - 28" [305mm - 711mm]

**Mounting** Side, bracket or hard mounting

**Travel** Slide length plus .88" [22.2mm]

**Hardware** #8 pan head screw

**Height** 1.38" [35.1mm]

**Features** Positive lock-out with front disconnect

**Load** 140 lbs.\*\* [64 kg.] per pair

Part Number	Slide Length	Slide Travel	Load Rating lbs/[kg] pair	A	B	C	D	E	F
305-A12-LR	12.00 [305]	12.88 [327]	140 [64]				10.25 [260.4]	10.75 [273.1]	
305-A14-LR	14.00 [356]	14.88 [378]	132 [60]			11.75 [298.5]	12.25 [311.2]	12.75 [323.9]	
305-A16-LR	16.00 [406]	16.88 [429]	125 [57]			13.75 [349.3]	14.25 [362.0]	14.75 [374.7]	9.87 [250.8]
305-A18-LR	18.00 [457]	18.88 [480]	116 [53]	8.37 [212.7]		15.75 [400.1]	16.25 [412.8]	16.75 [425.5]	11.87 [301.6]
305-A20-LR	20.00 [508]	20.88 [530]	107 [49]	9.37 [238.1]	14.37 [365.1]	17.75 [450.9]	18.25 [463.6]	18.75 [476.3]	13.87 [352.4]
305-A22-LR	22.00 [559]	22.88 [581]	100 [45]	10.37 [263.5]	16.37 [415.9]	19.75 [501.7]	20.25 [514.4]	20.75 [527.1]	15.87 [403.2]
305-A24-LR	24.00 [610]	24.88 [632]	93 [42]	11.37 [288.9]	18.37 [466.7]	21.75 [552.5]	22.25 [565.2]	22.75 [577.9]	17.87 [454.0]
305-A26-LR	26.00 [660]	26.88 [683]	86 [39]	12.37 [314.3]	20.37 [517.5]	23.75 [603.3]	24.25 [616.0]	24.75 [628.7]	19.87 [504.8]
305-A28-LR	28.00 [711]	28.88 [734]	80 [36]	13.37 [339.7]	22.37 [568.3]	25.75 [654.1]	26.25 [666.8]	26.75 [679.5]	21.87 [555.6]

\* Minimum order quantities may apply.

\*\* Load rating based on a 12" slide on a 16" wide drawer cycled 10,000 times.

## Installation Instructions

### Instructions to Bracket Mount

1. To ensure proper operation of the slides, make certain all mounting screws are inserted so that the screw heads are inside the slides. (No washers on the inside of the slides.)
2. Separate slide members by depressing the lock release lever.
3. Using mounting kits and brackets, mount brackets to slide cabinet member (largest) using #8-32 screws. See Figure 1. For adjustment purposes screw the rear brackets on loosely.
4. Install slides into EIA rack with (customer supplied) #10-32 screws and secure with bar nuts. Rear adjustment is possible by aligning the back bracket. Do not tighten screws until final adjustment is made.
5. Mount chassis members 1/8" from the front edge of the chassis making sure both slides are parallel.
6. With cabinet members in the closed position and ball retainers fully forward, install chassis by engaging the slide members and close completely. Check slide alignment by opening and closing the chassis. Any sign of binding indicates lateral stress or misalignment.
7. Adjust slide position until movement is smooth. Tighten all screws and if necessary use more screws to secure slides and complete installation.

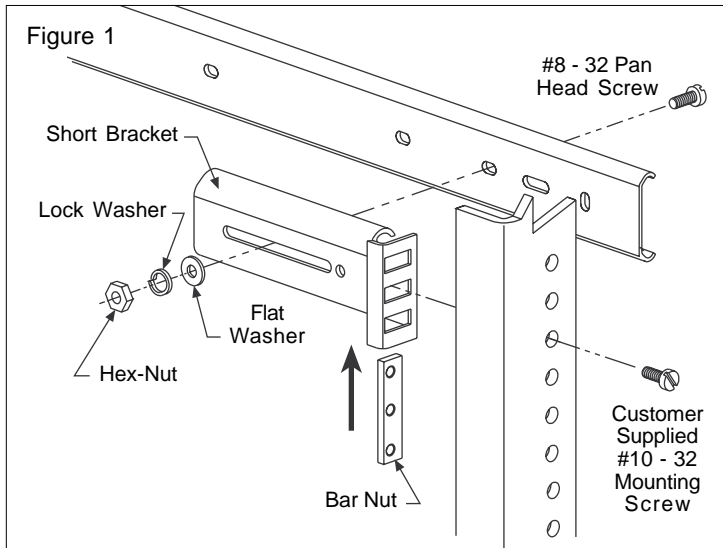

### Instructions to Hard Mount

1. Follow steps 1 and 2 of "Bracket Mount" instructions.
2. With slides fully extended, install slide cabinet members (largest) into cabinet using # 8 pan head screws through uncovered mounting slots. Move intermediate members to allow access to remaining slots. Be sure slides are parallel.
3. Mount chassis members. Access covered mounting holes by moving the intermediate members away from you. Leave all screws loose for future adjustment. Make sure slides are parallel.
4. Follow steps 6 and 7 of "Bracket Mount" instructions.

## Packaging

**Distributor (D) Pack:** All lengths are packaged 5 pair per box. Polybag includes one pair of slides packed with screws.

**Bulk (P) Pack:** Lengths 12" - 18" 12 pair per box  
Lengths 20" - 28" 5 pair per box

Order optional bracket mounting hardware kit (part number 4180-0223-XE) separately.

## Slide Ordering Instructions

Complete your slide order for model 305-ALR by specifying the following:

Total Slides Required \_\_\_\_\_ 10 Pair C 305 -A18-LR D  
Slide Finish \_\_\_\_\_  
Slide Model \_\_\_\_\_  
Slide Length \_\_\_\_\_  
Optional Polybag Packaging (includes mounting screws) \_\_\_\_\_

## Optional Hardware Kits - Ordered Separately

Kit contains mounting brackets and mounting hardware. Order 1 kit per pair of slides.

Total Bracket Kit Required \_\_\_\_\_ 10 Each 4180-0223-XE  
Optional Bracket Kit Part Number \_\_\_\_\_

Bracket kit includes 4 short brackets and a hardware kit which includes screws, hex-nuts, washers, and bar nuts to mount one pair of slides.

## Specifications

Slide members: Cold rolled steel  
Ball retainers: Cold rolled steel  
Ball bearings: Carburized steel

**Note:** Specifications, materials, prices, terms, and delivery are subject to change without notice.

# Accuride