

EM3870A - Evaluation Module for TGS3870

Description

This module facilitates evaluation of the characteristics of the **TGS3870** gas sensor for the detection of both methane and carbon monoxide. Testing is simplified by using a continuous output signal generated by this module. While the driving mode of TGS3870 involves a 20-second heater cycle for intermittent detection, sensor response is converted into a continuous voltage signal by the software contained in the module's microprocessor.

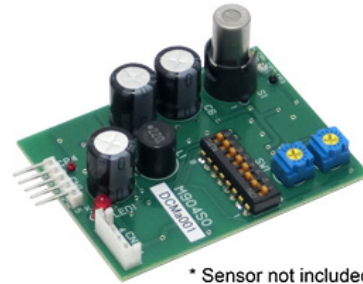

Structure and Dimensions

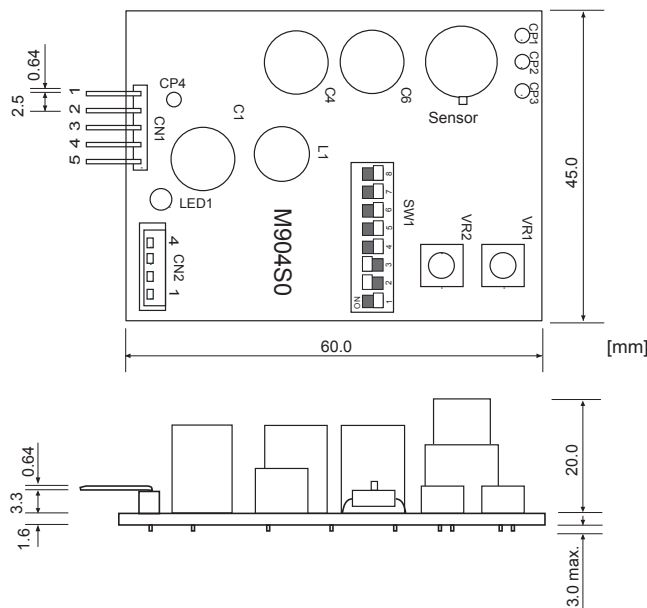

Circuit Diagram

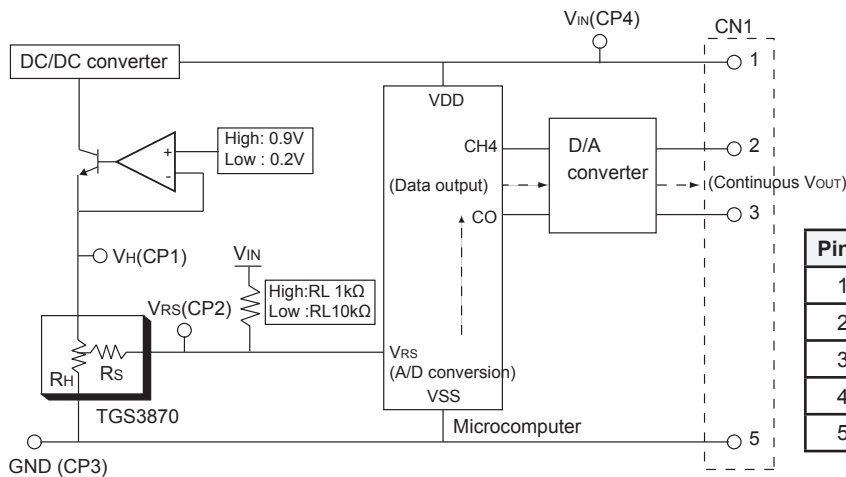

CN1 Pin Connections

Pin #	Label	Description	Specification
1	V _{IN}	Input voltage	4.9~5.1V DC
2	V _{OUT1}	Output (CH4)	-
3	V _{OUT2}	Output (CO)	-
4	NC	-	-
5	GND	Ground	-

Driving Condition

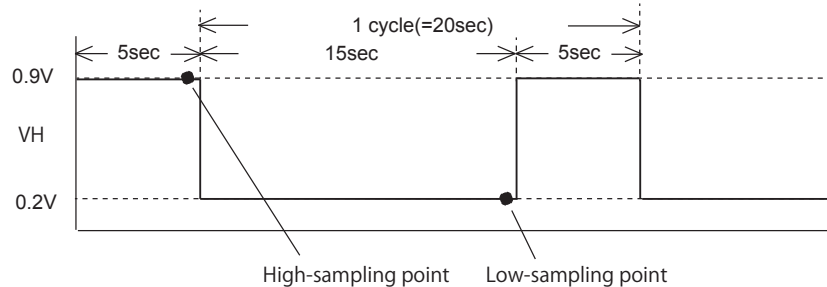

Calculating sensor resistance (Rs) from measured Vout

The VOUT1 and VOUT2 signals can be obtained by measuring the voltage between CN1 Pin #2 and Pin #5 for VOUT1, and between CH Pin #3 and Pin #5 for VOUT2 respectively (see CN1 Pin Connections). The VOUT values update once every 20 seconds per cycle. Sensor resistance (Rs) is calculated using the measured value of VOUT1 or VOUT2 according to the following formulas:

$$R_s(k\Omega) = \frac{V_C - V_{OUT}}{V_{OUT}} \times R_L$$

$$R_s(k\Omega) = \frac{5.0 - V_{OUT1}}{V_{OUT1}} \times R_{LCH4}$$

$$R_s(k\Omega) = \frac{5.0 - V_{OUT2}}{V_{OUT2}} \times R_{LCO}$$

RLCH4 = 1.0kΩ
RLCO = 10.0kΩ

Notes:

1. Evaluation use only

This module is designed for evaluation of the TGS3870 sensor only. Please do not use this module for any other purpose.

2. Power supply

Please apply the specified voltage to CN1 Pin #1 pin for proper sensor operation and performance. If excessive voltage or reverse voltage is applied to the module, the module or the sensor may be damaged. **Please note that there is no protection circuit in this module.**

3. VR1, VR2, and SW1

Please do not adjust VR1 or VR2 and do not change switch SW1. These items have been adjusted so that standard driving conditions are applied to the sensor. If they are changed, the sensor may be damaged.

4. Impedance of equipment connected to CN1

The input impedance of equipment connected to the CN1 must be more than 1MΩ in order to make precise data acquisition.

FIGARO GROUP

HEAD OFFICE

Figaro Engineering Inc.

1-5-11 Senba-nishi
Mino, Osaka 562-8505 JAPAN
Tel.: (81) 72-728-2561
Fax: (81) 72-728-0467
email: figaro@figaro.co.jp

OVERSEAS

Figaro USA Inc.

121 S. Wilke Rd. Suite 300
Arlington Heights, IL 60005 USA
Tel.: (1) 847-832-1701
Fax.: (1) 847-832-1705
email: figarousa@figarosensor.com