

PRODUCT NUMBER  
SEE SHEET 2

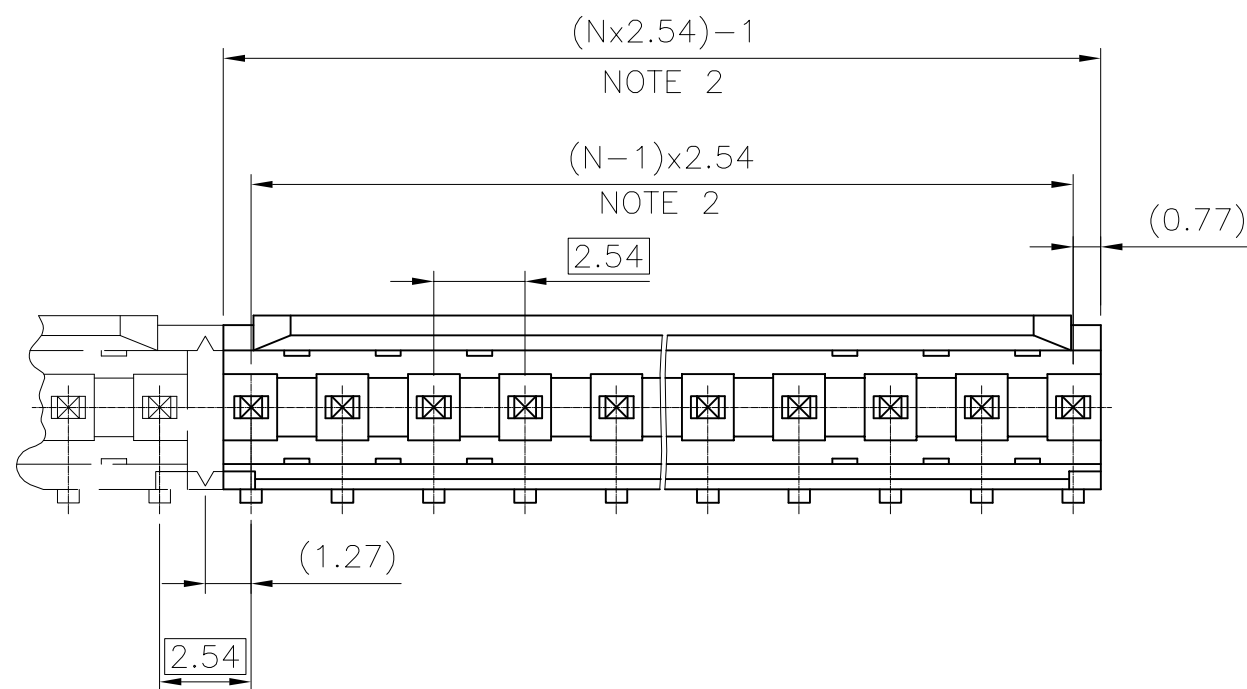

NOTES :

1. MINI PUSH-OUT FORCE TERMINAL IN BOTH DIRECTIONS 22N.
2. TO DETERMINE DIMENSIONS:  
N = NUMBER OF POSITIONS PER ROW  
EXAMPLE: 8 POS:  $(N \times 2.54) - 1 = 19.32$  mm

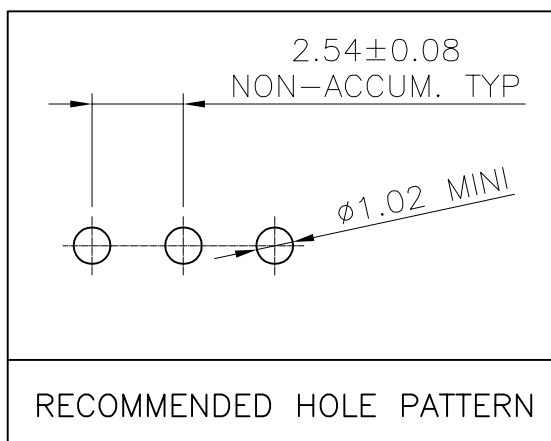
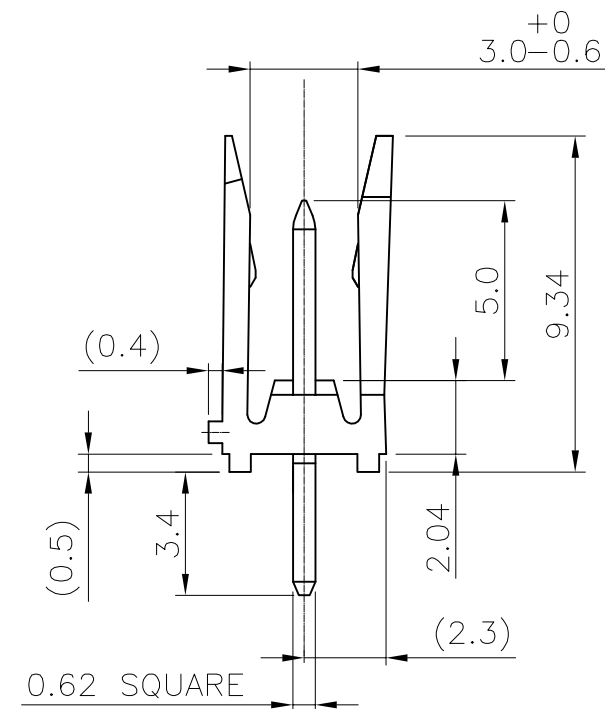
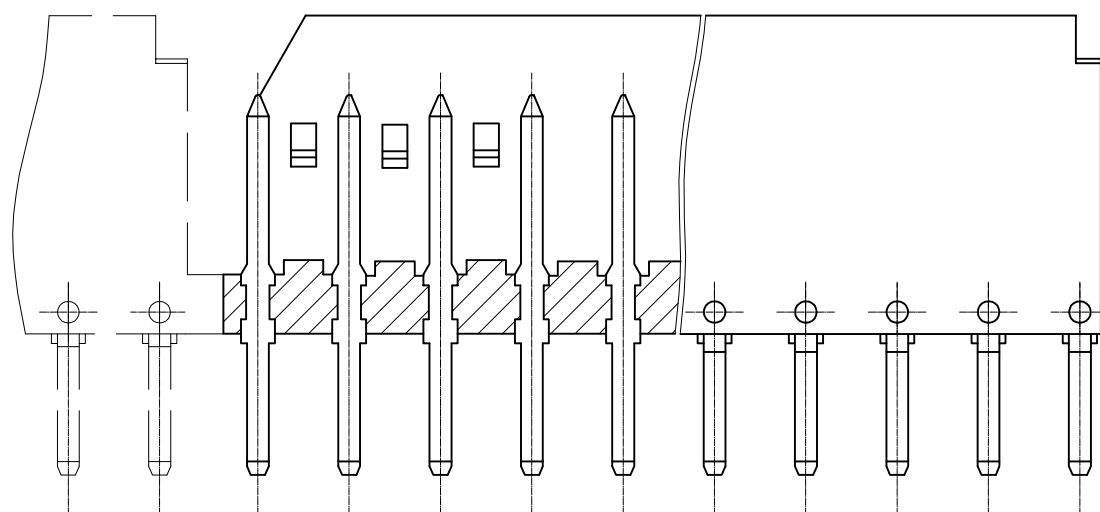

mat'l. code		surface		tolerance		projection		product family	
SEE NOTES		ISO 1302		ISO 406 ISO 1101		mm		DUBOX	
ltr	ecn no	dr	date	tolerances unless otherwise specified		mm		title	
N	F06-0228	LMU	06.07.11	angles	.X	scale 5:1		SHR. HEADER	
P	F06-0319	LMU	06.11.10	linear	.XX			STR SR TMT	
R	F07-0147	LMU	07.03.01		.XXX			dwg no	
S	F07-0220	J.CO	07.06.14	dr	D LEGRAND	99.03.03		sheet 1 of 2	
T	F08-0147	YOV	08.04.14	enr	JM PHAMVAN	99.03.03		size	
M	F05-0159	LMU	05.03.31	chr	JM PHAMVAN	99.03.03		A3	
		app	JM PHAMVAN			99.03.03		type	
sheet	revision	T	E					CUSTOMER Drawing	
index	sheet	1	2						



STANDARD PRODUCT NUMBER

76384-YXX

PLATING CODE \_\_\_\_\_ NUMBER OF POSITIONS: 02 TO 18.

- 3= 0.76µm GOLD/GXT ON CONTACT AREA.  
3.81µm TIN-LEAD ON TAIL OVER 1.27µm Ni MIN.
- 4= 3.81µm TIN LEAD OVER 1.27µm Ni MIN

NOTES:

- 1 - HOUSING MAT'L: THERMOPLASTIC GLASS FILLED  
FLAME RETARDANT PER UL 94 V-0 COLOR: BLUE.
- 2 - TERMINAL MATERIAL: COPPER ALLOY.
- 3 - 2 UP TO 6 POSITIONS, PRODUCT PACKED IN PLASTIC BAG.  
7 UP TO 18 POSITIONS, PRODUCT PACKED IN TUBE.
- 4 - ONLY DASH NUMBER -X02 AND -X03  
ALWAYS TEN (10) PRODUCTS MOLDED ASSEMBLY  
& DELIVERY TOGETHER ACCORDING PHANTOM LINES.

RoHS COMPLIANT PRODUCT NUMBER

76384-YXXLF

PLATING CODE \_\_\_\_\_

SUFFIX LETTER "LF" INDICATES THE PRODUCT IS RoHS COMPLIANT, SEE NOTE 5

- 3= 0.76µm GOLD/GXT ON CONTACT AREA.  
2µm MIN MATTE TIN ON TAIL.  
OVER 1.27µm Ni MIN
- 4= 2µm MIN MATTE TIN  
OVER 1.27µm Ni MIN

NOTES:

- 1 - HOUSING MAT'L: THERMOPLASTIC GLASS FILLED  
FLAME RETARDANT PER UL 94 V-0 COLOR: BLACK.
- 2 - TERMINAL MATERIAL: COPPER ALLOY.
- 3 - 2 UP TO 6 POSITIONS, PRODUCT PACKED IN PLASTIC BAG.  
7 UP TO 18 POSITIONS, PRODUCT PACKED IN TUBE.
- 4 - ONLY DASH NUMBER -X02 AND -X03  
ALWAYS TEN (10) PRODUCTS MOLDED ASSEMBLY  
& DELIVERED ON STRIP ACCORDING PHANTOM LINES.
- 5 - RoHS COMPATIBLE PRODUCT SPECIFICATIONS
  - a - PLATING:
    - "LF" MEANS THE PRODUCT IS LEAD-FREE,  
2µm MINIMUM MATTE TIN OVER 1.27µm  
MINIMUM NICKEL UNDERPLATE.
  - b - MANUFACTURING PROCESS COMPATIBILITY
    - THE HOUSING WILL WITHSTAND EXPOSURE TO  
260°C ±5°C SOLDER BATH TEMPERATURE FOR  
5 SECONDS IN A WAVE SOLDER APPLICATION  
WITH A 1.6mm MIN THICK CIRCUIT BOARD.
  - c - LABELING:
    - MEETS PACKAGING SPECS AS PER GS-14-920
  - d - LEGAL STATEMENT: SEE GS-22-008

mat'l. code SEE NOTES				surface ISO 1302	tolerance ISO 406 ISO 1101	projection	product family DUBOX
ltr	ecn no	dr	date	tolerances unless otherwise specified		mm	title SHR. HEADER STR SR TMT
A	F05-0159	LMU	05.03.31	angles	.X ±0.3		
B	F06-0228	LMU	06.07.11	linear	.XX ±0.15		
C	F07-0147	LMU	07.03.01		.XXX ±0.05	scale 5:1	
D	F07-0220	JCO	07.06.14	dr	L.MULIN 05.03.25	FCJ	dwg no 76384
E	F08-0147	YOY	08.04.14	enr	J.COMPAGNON 05.03.25		sheet 2 of A3
				chr			type CUSTOMER Drawing
sheet index	revision sheet						



Copyright FCI